



Standard Test Method for Evaluation of Automotive Engine Oils for Inhibition of Deposit Formation and Wear in a Spark-Ignition Internal Combustion Engine Fueled with Gasoline and Operated Under Low-Temperature, Light-Duty Conditions¹

This standard is issued under the fixed designation D 5302; the number immediately following the designation indicates the year of original adoption or, in the case of revision, the year of last revision. A number in parentheses indicates the year of last reappraisal. A superscript epsilon (ε) indicates an editorial change since the last revision or reappraisal.

1. Scope

1.1 This test method is commonly referred to as the Sequence VE test² and has been correlated with vehicles used in stop-and-go service prior to 1988, particularly with regard to sludge and varnish formation and valve train wear.³ It is one of the test methods required to evaluate oils intended to satisfy the API SJ performance category.

1.2 The values stated in either inch-pound units or SI units are to be regarded separately as the standard. Within the text, the SI units are shown in parentheses when combined with inch-pound units. Some of the figures and forms have identical numerical designations, but with the letter *M* following the numerical designation: these are alternative figures and forms that contain SI units.

1.3 *This standard does not purport to address all of the safety concerns, if any, associated with its use. It is the responsibility of the user of this standard to establish appropriate safety and health practices and determine the applicability of regulatory limitations prior to use.* Specific precautionary statements are given in 7.7, 7.8.9.6, 7.8.13, 7.10.2, 7.10.3.2(c), 8.3.4.2, 8.4.4.3, 8.4.5.2, 9.3.4.4, 9.6.1.2, 12.1.1.5, 12.1.4.5, 12.2.1, 12.2.1.5, Fig. A3.6, and Annex A8.

1.4 Table of Contents:

	Section
Scope	1
Referenced Documents	2
Terminology	3
Summary of Test Method	4
Significance and Use	5

Apparatus—General Description	6
Apparatus—The Test Engine	7
Sequence VE Test Engine Parts Kit	7.1
Required New Engine Parts	7.2
Reusable Engine Parts	7.3
Specially Fabricated Engine Parts	7.4
Special Engine Measurement and Assembly Equipment	7.5
Miscellaneous Engine Components-Preparation	7.6
Solvents and Cleansers Required	7.7
Assembling the Test Engine—Preparations	7.8
Assembling the Test Engine—Installations	7.9
Engine Installation on the Test Stand	7.10
Engine Fluids—Supply/Discharge Systems	8
Intake Air	8.1
Fuel	8.2
Engine Oil	8.3
Coolants	8.4
Measurement Instrumentation	9
Temperatures	9.1
Pressures	9.2
Flow Rates	9.3
Fuel Consumption	9.4
Speed and Load	9.5
Exhaust Gas	9.6
Miscellaneous Laboratory Equipment	10
Test Stand Calibration	11
Verification	11.1
Unacceptable Calibration Tests	11.2
Test Stand Modifications	11.3
Reference Oil Accountability	11.4
Test Numbering System	11.5
Procedure	12
Pre-Test Procedure	12.1
Engine Operating Procedure	12.2
Periodic Measurements and Functions	12.3
Special Maintenance Procedures	12.4
Diagnostic Data Review	12.5
End of Test Procedure	12.6
Interpretation of Results	13
Parts Rating Area—Environment	13.1
Sludge Ratings	13.2
Varnish Ratings	13.3
Clogging	13.4
Sticking	13.5
Wear Measurements	13.6
Assessment of Test Validity	14
Average Exhaust Gas NO _x Levels	14.2
Used Oil Analyses	14.3
Blowby Flow Rate	14.4
Intake Manifold Vacuum	14.5
Fuel Consumption Rate	14.6
Oil Consumption	14.7
Report	15
Report Format	15.1

¹ This test method is under the jurisdiction of ASTM Committee D02 on Petroleum Products and Lubricants and is the direct responsibility of Subcommittee D02.B0.01 on Passenger Car Engine Oils.

Current edition approved Nov. 10, 2000. Published December 2000. Originally published as D 5302 – 95. Last previous edition D 5302 – 00.

² Until the next revision of this test method, the ASTM Test Monitoring Center will update changes in the test method by means of information letters. Information letters may be obtained from the ASTM Test Monitoring Center, 6555 Penn Avenue, Pittsburgh, PA 15206-4489. Attention: Administrator. This edition incorporates revisions in all Information Letters through No. 99-3.

³ ASTM Research Report RR:D02:1226. Sequence VE Report to the Subcommittee D02.B Oil Classification Panel, contains the field-laboratory correlation information and the initial laboratory test precision data.

Special Forms for Automated Data Acquisition Standard Report	15.2
Calibration Test Report	15.3
Precision and Bias	15.4
Precision	16
Bias	16.1
	16.2
ANNEXES	
Special Service Tools for the Test Engine	A1
External Oil Heat Exchanger Cleaning Technique	A2
Detailed Specifications and Photographs of Apparatus	A3
Engine Part Number Listing	A4
Operational Data Log Sheets	A5
Rating Worksheets	A6
Final Report Forms and Photographs	A7
Safety Precautions	A8
Automatic Data Acquisition	A9
Oakite 811 Monitoring Program	A10
Test Precision—Reference Oils	A11
Control Chart Technique for Severity Adjustment	A12
Statistical Equations for Mean and Standard Deviation	A13
Data Dictionary	A14
One-half Millimetre Oversize Piston Modifications	A15
Required Inspections and Operations for Reuse of Cylinder Heads	A16
APPENDIXES	
Engine Measurement Sheets	X1
Sources of Materials and Information	X2
Analysis of Phillips “J” Fuel (Batch 26)	X3
Theoretical Exhaust Gas Relationships-Phillips “J” Fuel	X4
Description of Scott Quarterly Gas Audit Service	X5

2. Referenced Documents

2.1 ASTM Standards:

- D 86 Test Method for Distillation of Petroleum Products⁴
- D 287 Test Method for API Gravity of Crude Petroleum and Petroleum Products (Hydrometer Method)⁴
- D 323 Test Method for Vapor Pressure of Petroleum Products (Reid Method)⁴
- D 381 Test Method for Existent Gum in Fuels by Jet Evaporation⁴
- D 445 Test Method for Kinematic Viscosity of Transparent and Opaque Liquids (the Calculation of Dynamic Viscosity)⁴
- D 525 Test Method for Oxidation Stability of Gasoline (Induction Period Method)⁴
- D 873 Test Method for Oxidation Stability of Aviation Fuels (Potential Residue Method)⁴
- D 893 Test Method for Insolubles in Used Lubricating Oils⁴
- D 1266 Test Method for Sulfur in Petroleum Products (Lamp Method)⁴
- D 3237 Test Method for Lead in Gasoline by Atomic Absorption Spectrometry⁵
- D 3525 Test Method for Gasoline Diluent in Used Gasoline Engine Oils by Gas Chromatography⁵
- D 3606 Test Method for the Determination of Benzene and Toluene in Finished Motor and Aviation Gasoline by Gas Chromatography⁵
- D 4057 Practice for Manual Sampling of Petroleum and Petroleum Products⁵
- D 4175 Terminology Relating to Petroleum, Petroleum Products, and Lubricants⁵
- D 4485 Specification for Performance of Engine Oils⁵
- D 5134 Test Method for Detailed Analysis of Petroleum

⁴ Annual Book of ASTM Standards, Vol 05.01.

⁵ Annual Book of ASTM Standards, Vol 05.02.

Naphthas Through n-Nonane by Capillary Gas Chromatography⁶

G 40 Terminology Relating to Wear and Erosion⁷

2.2 SAE Standards:

SAE J254 Instrumentation and Techniques for Exhaust Gas Emissions Measurement⁸

2.3 ANSI Standard:

MC96.1 Temperature Measurement—Thermocouples⁹

2.4 Coordinating Research Council:

CRC Sludge Rating Manual (CRC Manual No. 12)¹⁰

CRC Varnish Rating Manual (CRC Manual No. 14)¹⁰

CRC Techniques for Valve Rating (CRC Manual No. 16)¹⁰

3. Terminology

3.1 Definitions:

3.1.1 *air-fuel ratio, n—in internal combustion engines*, the mass ratio of air-to-fuel in the mixture being induced into the combustion chambers.

3.1.1.1 *Discussion*—In this test method, air-fuel ratio is controlled indirectly by exhaust gas analysis for CO and O₂ contents. During Stages I and II, O₂ is the primary determinant, while CO is the primary determinant in Stage III.

3.1.2 *blowby, n—in internal combustion engines*, the combustion products and unburned air/fuel mixture that enter the crankcase.

3.1.3 *cold-stuck piston ring, n—in internal combustion engines*, one that is stuck when the piston and ring are at room temperature, but inspection indicates that it was free during engine operation.

3.1.3.1 *Discussion*—A cold-stuck piston ring cannot be moved with moderate finger pressure. It is characterized by a polished face over its entire circumference, indicating essentially no blowby passed over the outside of the ring during engine operation.

3.1.4 *debris, n—in internal combustion engines*, contaminant materials unintentionally introduced into the engine.

3.1.4.1 *Discussion*—Examples include such things as gasket material, silicone sealer, towel threads, and metal particles.

3.1.5 *free piston ring, n—in internal combustion engines*, one that will fall in its groove under the force of its own weight when the piston is moved from a horizontal position to a vertical one.

3.1.5.1 *Discussion*—A slight touch to overcome static friction is permissible.

3.1.6 *hot-stuck piston ring, n—in internal combustion engines*, a piston ring that is stuck when the piston and ring are at room temperature, and inspection shows that it was stuck during engine operation.

3.1.6.1 *Discussion*—The portion of the ring that is stuck cannot be moved with moderate finger pressure. A hot-stuck

⁶ Annual Book of ASTM Standards, Vol 05.03.

⁷ Annual Book of ASTM Standards, Vol 03.02.

⁸ Available from Society of Automotive Engineers, 400 Commonwealth Drive, Warrendale, PA 15096.

⁹ Available from American National Standards Institute, 11 W. 42nd St. 13th Floor, New York, NY 10036.

¹⁰ Available from Coordinating Research Council, Inc., 219 Perimeter Ctr. Parkway, Atlanta, GA 30346.

ring is characterized by varnish or carbon across some portion of its face, indicating that portion of the ring was not contacting the cylinder wall during engine operation.

3.1.7 *knock, n—in a spark ignition engine*, abnormal combustion, often producing audible sound, caused by autoignition of the air/fuel mixture (see Terminology D 4175).

3.1.8 *scoring, n—in tribology*, a severe form of wear characterized by the formation of extensive grooves and scratches in the direction of sliding (see Terminology G 40).

3.1.9 *scuffing, n—in lubrication*, surface damage resulting from localized welding at the interface of rubbing surfaces with subsequent fracture in the proximity of the weld area (see Terminology D 4175).

3.1.10 *sludge, n—in internal combustion engines*, a deposit, principally composed of insoluble resins and oxidation products from fuel combustion and the lubricant, that does not drain from engine parts but can be removed by wiping with a cloth.

3.1.11 *tight piston ring, n—in internal combustion engines*, one that will not fall in its groove under its own weight when the piston is moved from a horizontal position to a vertical one, but the ring can be displaced by moderate finger pressure.

3.1.12 *varnish, n—in internal combustion engines*, a hard, dry, generally lustrous deposit that can be removed by solvents but not by wiping with a cloth.

3.1.13 *wear, n*—the loss or relocation of material from a surface.

3.1.13.1 *Discussion*—Wear generally occurs between two surfaces moving relative to each other, and is the result of mechanical or chemical action or by a combination of mechanical and chemical actions.

3.2 Definitions of Terms Specific to This Standard:

3.2.1 *clogging, n*—the restriction of a flow path due to the accumulation of debris along the flow path boundaries.

3.2.2 *closed-loop lambda control system, n*—one that functions by feeding back a direct measurement of lambda through a fully closed loop, and uses the measurement to alter the fuel input by changing the fuel injector pulse width.

3.2.3 *enrichment, n—in internal combustion engine operation*, a fuel consumption rate in excess of that which would achieve a stoichiometric fuel-to-air ratio.

3.2.3.1 *Discussion*—Enrichment is usually indicated by elevated CO levels and can also be detected with an extended range air/fuel ratio sensor.

3.2.4 *lambda, n*—the ratio of actual air mass induced, during engine operation, divided by the theoretical air mass requirement at the stoichiometric air-fuel ratio for the given fuel.

3.2.5 *open loop lambda control system, n*—one that utilizes manual adjustment of the fuel injector pulse width to alter lambda based on manual measurement of exhaust gas CO and O₂ content.

3.2.6 *low-temperature, light-duty conditions, n*—indicative of engine oil and coolant temperatures that average below normal warmed-up temperatures, and engine speeds and power outputs that average below those encountered in typical highway driving.

3.2.7 *ramping, n*—the prescribed rate of change of a variable when one set of operating conditions is changed to another

set of operating conditions.

4. Summary of Test Method

4.1 Each test engine is assembled with many new parts and essentially all aspects of assembly are specified in detail.

4.2 The 2.3-L internal combustion engine is installed on a test stand, which is equipped to control speed and load and various other operating parameters.

4.3 The engine is operated for a total of 288 h, consisting of 72 repetitive cycles of 4 h each. Each cycle consists of three stages.

4.4 While the operating conditions are varied within each cycle, overall they can be characterized as a mixture of low-temperature and moderate-temperature, light-duty operating conditions.

4.5 To accelerate deposit formation and engine wear, the level of oxides of nitrogen in the blowby and the rate of blowby into the crankcase are significantly increased, the fresh air breathing of the crankcase is significantly decreased, and the transitions between two of the stages of operation are deliberately enriched, in comparison with normal operation.

4.6 The test engine oil's performance is determined at the end of the test by dismantling the engine and measuring the deposition and wear.

5. Significance and Use

5.1 This test method is used to evaluate an automotive engine oil's control of engine deposits and wear under operating conditions deliberately selected to accelerate deposit formation and wear. This test method was correlated with field service data, determined from side-by-side comparisons of two or more oils in taxi fleets and delivery van services, as examples. The same field service oils were then used in developing the operating conditions of this test procedure.

5.2 This test method, along with other test procedures, defines the minimum performance level of the API Categories SH and SJ (detailed information about these categories is included in Specification D 4485). This test method is also incorporated in U.S. Army and automobile manufacturers' factory-fill specifications.

5.3 The basic engine used in this test method is representative of many that are in modern automobiles, but not all. This factor, along with the accelerated operating conditions, should be considered when extrapolating test results.

6. Apparatus

6.1 General Description:

6.1.1 The test engine is a 2.3-L, spark ignition, four-stroke, four-cylinder in-line engine. Features of this engine include an overhead camshaft, a cross-flow fast-burn cylinder head design, and electronic port fuel ignition. It is based on the Ford Motor Company's 2.3-L EFI Ranger¹¹ truck engine.

6.1.2 Use an engine test stand equipped to control engine speed and load, air-fuel ratio, various temperatures, and other parameters.

6.1.3 Use appropriate air conditioning apparatus to control the temperature and humidity of the intake air.

¹¹ Ford Ranger is a product of the Ford Motor Co., Dearborn, MI 48121.

6.1.4 Use an appropriate fuel supply system.

7. The Test Engine

7.1 *Sequence VE Test Engine Parts Kit*—The kit is available from the Ford Motor Company and contains all the necessary consumable hardware for four tests. Tests starting after May 31, 1995, shall use 1992 or later test engine parts kits with the dual plug cylinder head. A complete list of parts included in the kit is shown in Table A4.1.

7.1.1 The following required parts are to be obtained from the kit (unless substitutions for those parts are specifically approved by the Sequence VE Operations and Hardware Subpanel (contact the ASTM Test Monitoring Center (TMC) for guidance): cylinder block, cylinder head, pistons, piston rings, camshaft, rocker arms, and connecting-rod bearings.

7.1.1.1 Tests started on or after November 16, 1999 may use substitute non-kit parts (other than those listed in 7.1.1) obtained from Ford dealers, provided that the part numbers are the same as those in the kit. Where parts substitutions are made, maintain samples of the substituted part for possible comparison. Identify all substituted parts with the part numbers on the Supplemental Operational Data Form of the test report (Fig. A7.5). Coordinate the use of substituted parts with the TMC.

7.1.2 Premeasured and calibrated Sequence VE engine parts are available from the supplier listed in X2.1.5.

7.2 *Required New Engine Parts*—Install the following new parts in each new test engine assembly: cylinder head (may be reused for tests starting on or before May 20, 1999) cylinder head bolts (torque-to-yield), camshaft, camshaft bearings, camshaft drive belt, rocker arms, hydraulic lifters, intake and exhaust valves, valve stem seals, pistons, piston rings, wrist pins, connecting-rod bearings, main bearings, oil pump, oil filter, PCV valve, spark plugs, and gaskets and seals.

7.3 *Reusable Engine Parts*—The following parts can be reused: cylinder block (can be used for approximately two tests, depending on bore wear); valve springs (can be reused as long as they meet the specifications detailed in Annex A3); cylinder heads (for tests started on or after May 20, 1999, provided an acceptable reference oil test, incorporating reused cylinder heads and meeting the requirements in Annex A16, has been completed); auxiliary shaft and bearings, connecting rod, front seal housing, fuel management wiring harness, crankshaft ignition trigger, intake manifold, throttle body, camshaft drive parts, water pump drive parts, crankshaft, fuel injectors, ignition module, ignition wires, oil pump screen and pick up tube, timing belt sprockets, and water pump (all of these can be used in numerous engine assemblies as long as they remain serviceable).

7.4 *Specially Fabricated Engine Parts*—The following subsections detail the specially fabricated engine parts required in this test method:

7.4.1 *Intake Air Horn* (see Fig. 1 and Fig. A3.4) :

7.4.2 *Camshaft Baffle* (see Fig. A3.24)—This is fabricated for attachment to the cam bearing pedestals. The clearance between the edges of the baffle and the rocker arm cover (RAC) permits a limited splash flow of oil to the top of the baffle and the RAC. Therefore, the dimensional accuracy of the baffle is important to minimize the influence on test severity.

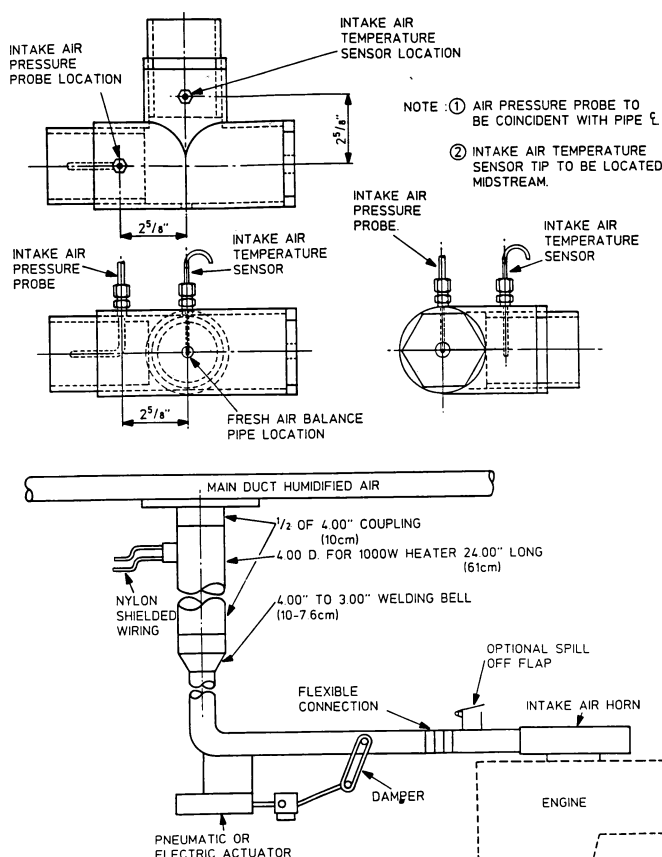

FIG. 1 Intake-Air Horn Adapter and Typical Test Stand Air Supply Duct

The camshaft baffle is available from the supplier listed in X2.1.13.

7.4.3 *Crankcase Oil Fill Tube* (see Fig. A3.27)—This design is not a requirement, but if an alternative part is used, install a suitable shut-off valve between the fill tube and the engine.

7.4.4 *Dipstick Tube*—Replace the existing dipstick tube with a 1/8-in. NPT pipe nipple. The nipple should be approximately 6-in. (150-mm) long and is threaded into the port on the left side of the crankcase, as shown in Fig. A3.13.

7.4.5 *Dipstick*—Use the special dipstick shown in Fig. A3.28 to measure the oil level in the modified oil pan.

7.4.6 *Oil Pan*—Obtain the special oil pan shown in Fig. A3.25 from the supplier listed in X2.1.13.

7.4.7 *Flywheel Timing Indicator*—Fabricate a bracket with an adjustable timing index pointer for use at the flywheel. Mark the flywheel with graduations at top dead center (TDC) and from 26 to 30° in 1° increments before top dead center (BTDC) and after top dead center (ATDC). The suggested mounting location is between two of the flywheel housing bolts on the upper left side of the crankcase. Since ignition timing is measured with an accuracy of 1°, configure the index pointer to minimize parallax error.

7.4.8 *Rocker Arm Cover*—The RAC is fabricated from stainless steel and incorporates a water jacket. The RAC supplier is listed in X2.1.13.

7.5 *Special Engine Measurement and Assembly*

Equipment—Items routinely used in the laboratory and workshop are not included.

7.5.1 Camshaft and Rocker Arm Hardness Tester and Fixtures—Use a hardness tester to measure the camshaft lobe and rocker arm hardness in the range from 50 to 60 HRC (Hardness—Rockwell C). The tester and fixtures shall allow accurate and repeatable results at the specified locations on these parts (see 7.8.6.3 and 7.8.7).

NOTE 1—Repeatable hardness measurements are difficult to achieve without properly designed fixtures.

7.5.2 Camshaft Lobe Measurement Equipment—A snap gage dial indicator is recommended for measurement of camshaft lobe heel-to-toe distance.

7.5.3 Camshaft Lobe Orifice Flow Rate Device:

7.5.3.1 Determine camshaft lobe orifice plugging with the device detailed in Fig. A3.32. The device measures restriction of air flow relative to a clean lobe by means of a probe placed in the external opening to each lobe orifice. The device shall be capable of controlling static air pressure at 10.0 in. water (2.49 kPa).

7.5.3.2 Calibrate the flowmeter with a reference (clean) cam lobe each time a camshaft is rated for plugging. Since the measurement is a relative flow rate reduction, repeatability, rather than absolute accuracy, is the primary concern (see Fig. A3.32 and 13.4.4).

7.5.4 Rocker Arm and Connecting-Rod Bearing Weighing Equipment—A precision weight scale with an accuracy of 0.25 % and a resolution of 0.1 mg is necessary. Rocker arm weights are approximately 105 g, while individual bearing insert weights are approximately 20 g.

7.5.5 Unassembled Valve Spring Calibration Device—Use this device to screen valve springs before assembly in the cylinder head (see 7.8.8.3). The spring loading is measured at a compressed height of 1.16 in. (29.5 mm). The tester shall have an accuracy of 2 % and a resolution of 1 lbf (4.45 N).

7.5.6 Assembled Valve Spring Calibration Device:

7.5.6.1 This device is used to measure valve spring loading after the springs have been assembled in the cylinder head. Use the procedure specified in 7.8.8.5 in conjunction with the device. A suitable fixture may be purchased from the supplier detailed in X2.1.13 and X2.1.5.

7.5.6.2 Calibrate the valve spring force measurement device at least once every three months. The calibration technique is left to the discretion of the testing laboratory.

7.5.7 Valve Stem and Guide Measurement Equipment—Any of the following methods is acceptable for measuring valve stem-to-guide clearance (see 7.8.6.1). One method is specified in Footnote 14¹² utilizing a special tool. Other commercially available automotive service equipment can also be utilized. Alternatively, air gaging equipment can be used to measure the guide diameter, and a micrometer can be used to measure the valve stem diameter.

NOTE 2—Accurate measurement of stem-to-guide clearance is important since this parameter can affect oil consumption.

7.5.8 Connecting-Rod Heater—The piston pins are fixed to

the connecting-rods with an interference fit. A connecting-rod heater¹³ is required to facilitate the installation of the piston pins and prevent piston distortion (see 7.8.13). This type of heater minimizes the heat exposure of the rods and consequently minimizes the safety hazard to personnel.

7.5.9 Cylinder Block Stress Plates—Install two stress plates on the cylinder block during honing and measurement operations to minimize cylinder bore out-of-round and taper. Fabricate one plate in accordance with the details shown in Fig. A3.36. The second stress plate can be purchased from the supplier detailed in X2.1.28. Install the thinner of the two plates on top.

7.5.10 Cylinder Block Honing Machine— Use a Sunnen CK-10 or CV-616 honing machine¹⁴ for cylinder bore resizing and finishing. The Sunnen honing lubricant or Mobil VAC-MUL 3-D lubricant,¹⁵ a 30-tooth ratchet, and EHU-525 and JHU-625 (or JHU-820) honing stones are required in this application. See Table 1.

7.5.11 Cylinder Bore Surface Finish Analyzer:

7.5.11.1 The analyzer is required to measure the cylinder bore surface finish after completion of the honing operation. The range of the analyzer shall cover a minimum from 8 to 20 μ in. (0.0002 to 0.0005 mm). An instrument with a mechanically driven profilometer stylus is recommended since repeatable measurements are difficult to achieve with a hand-held instrument.

7.5.11.2 Calibrate the surface finish analyzer with a commercially recognized surface finish calibration standard. The frequency of calibration shall comply with the manufacturer's specification for the particular analyzer used.

7.5.12 Cylinder Bore Measurement Ladder— The bore measurement ladder is required to ensure precise location of the cylinder bore measurement at the top, middle, and bottom of the piston ring travel. Fabricate the bore ladder in accordance with the details shown in Fig. A3.38.

7.5.13 Piston Ring Positioner—Use the piston ring positioner to locate the piston rings 2.0 in. (51 mm) from the upper surface of the stress plate. This allows the compression rings to

¹³ The Sunnen Model CRH-50 Rod Heater, or equivalent, is suggested for this purpose. Information on availability is given in X2.24 .

¹⁴ The Sunnen CK-10 and CF-616 honing machines and the Sunnen honing lubricant are products of Sunnen Inc., 7910 Manchester, St. Louis, MO 63143.

¹⁵ Mobil VACMUL 3-D lubricant is a product of Mobil Oil Corp., 3225 Gallows, Fairfax, VA 22037.

TABLE 1 Honing Machine Set Up

Parameter	Honing Machine Model Number	
	CK-10	CV-616
Spindle speed, r/min	155	170
Stroke rate, s/min	46	57
Feed ratchet	3 or 4	2 or 3
Position	30 tooth gear	...
Lubricant flow rate	50 % of maximum	50 % of maximum
Desired Microfinish	Honing Stone Selection	
8 to 14 μ in. AA (0.20 to 0.36 μ m)	EHU-525 rough JHU-820 finish	
15 to 20 μ in. AA (0.38 to 0.51 μ m)	EHU-525 rough JHU-625 finish	

¹² Ford Shop Manual-Ranger/Bronco II, FPS 1987.

be positioned in a standard location in the cylinder bore before measurement. Fabricate the positioner in accordance with the details shown in Fig. A3.37.

7.5.14 Piston Ring Grinder—A precision ring grinder is required for adjusting ring gaps before assembly. A suitable ring grinder is available from the supplier shown in X2.1.21.

7.5.15 Oil Pump Calibration Device:

7.5.15.1 Calibrate the engine oil pump by precisely adjusting the pressure relief valve, utilizing a calibration device similar to the one detailed in Fig. A3.30 and Fig. A3.31. The device drives the pump at a constant speed and circulates Mobil EF-411 oil,¹⁶ while the oil temperature and flow rate are controlled. The pump discharge pressure is adjusted by means of the pressure relief valve. The oil flow rate sensor and readout shall have an accuracy of 2 % of full scale and a resolution of 0.1 gpm. The pressure measurement system shall have an accuracy of 1.0 % of full scale and a resolution of 0.5 psig (3.4 kPa).

7.5.15.2 Calibrate the oil pump calibration device at least once every three months. The calibration technique is left to the discretion of the testing laboratory.

7.5.16 PCV Valve Flow Rate Device:

7.5.16.1 Use this device to verify the flow rate of the PCV valves before the test and to measure the degree of clogging after the test is completed. Fabricate the device in accordance with the details shown in Fig. A3.34. The device shall have an accuracy of 5 % of full scale and a resolution of 0.1 cfm (0.047 L/s) (see 7.6.9).

7.5.16.2 Calibrate the flow rate device once every six months against a standard traceable to national standards. Perform calibration checks biweekly, or more frequently with modified PCV housings that contain fixed orifices (see Fig. A3.35).

7.5.17 Probe for Engine Timing Calibration—Use the cylinder probe to calibrate the crankshaft pulley and the flywheel at TDC of the Number 1 piston.

7.5.18 Engine Service Tools—A complete list of special tools for the test engine is shown in Annex A1. The tools are available from a Ford dealer or from the supplier listed in X2.1.27. These are designed to aid in performing several service items, in addition to the following specific service items that require special tools to perform the functions indicated (if not self-explanatory):

7.5.18.1 Camshaft Belt Tension Adjusting Tool, (Part No. T74P-6254-A).

7.5.18.2 Valve Spring Compressor Lever, necessary for rocker arm installation. (Part No. T74P-6565-A.)

7.5.18.3 Engine Plug Replacer, necessary for freeze plug installation. (Part No. T74P-6015-A.)

7.5.18.4 Camshaft and Auxiliary Shaft Seal Replacer, (Part No. T74P-6150-A).

7.5.18.5 Fuel Injector Test Rig—A suitable device capable of accurate, repeatable flow measurement of port fuel injectors is required. This device shall be capable of performing necessary port fuel injector evaluations, as outlined in 7.6.11. Since

no suitable commercially available apparatus has been identified, design of the test rig is left up to the laboratory.

7.6 Miscellaneous Engine Components—Preparation:

7.6.1 Engine Buildup and Measurement Area—Environment—The ambient atmosphere of the engine buildup and measurement areas shall be reasonably free of contaminants. A relatively constant temperature (within $\pm 3^{\circ}\text{C}$) is necessary to ensure acceptable repeatability in the measurement of parts dimensions. The relative humidity should be maintained at less than 75 % to prevent moisture forming on cold engine parts that are brought into the buildup or measurement areas.

7.6.2 Oil Pump:

7.6.2.1 Calibrate the oil pump to help provide uniform oil flow rates from test-to-test. The oil pump is calibrated with an oil pump calibration device (see Figs. A3.30 and A3.31, and 7.5.15.1). The oil pump relief adjuster assembly replaces the blanking plug and is used to position the relief valve spring during calibration and operation (see Fig. A3.29).

7.6.2.2 The oil pressure relief valve assembly is located behind the blanking plug. The plug is difficult to remove, and it may be necessary to apply heat to the oil pump casing to break down the thread locking adhesive. After the blanking plug has been removed, install the adjuster assembly.

7.6.2.3 Mount the oil pump on the calibration device. Fill the calibration device with EF-411 oil and circulate and heat the oil until it reaches $125 \pm 5^{\circ}\text{F}$ ($51.7 \pm 2.8^{\circ}\text{C}$). Adjust the oil pump speed to 1250 ± 10 rpm (130 ± 1 rad/s), and set the flow rate at 6.6 ± 0.1 gal/min (0.420 ± 0.006 L/s). Adjust the relief valve spring tension until the pump output pressure registers 60 ± 1 psig (414 ± 7 kPa).

7.6.2.4 If oil pressure fluctuations are observed during calibration, disassemble the relief valve and correct the problem. Significant air entrainment in the oil in the calibration device indicates unacceptable leakage on the suction side of the pump.

7.6.3 Oil Pump Pickup Tube and Screen—Clean the oil pickup tube and screen assembly, and inspect the assembly for defects.

7.6.4 Throttle Body:

7.6.4.1 The required throttle body modifications are detailed in Fig. A3.19. Remove all tubes and plug the holes with pipe plugs and a suitable thread sealer. Remove and discard the outer and inner throttle body shaft seals. Use of the throttle position sensor and the multiplier linkage is optional.

7.6.4.2 Disassemble and thoroughly clean the throttle body before each test. Remove the butterfly from the throttle shaft, and remove the shaft from the throttle body. Discard the rubber throttle body shaft seals, and soak all parts in a commercially available carburetor cleaner. After the parts have been thoroughly cleaned and air-dried, install new throttle body shaft seals. The seals should be lightly lubricated on all surfaces with EF-411 oil to facilitate installation. Do not use any other lubricant on the seals. Reassemble the throttle body.

7.6.4.3 There is no specific life for the throttle body. However, the clearance between the bore and the butterfly will eventually increase and render the body unserviceable. When the clearance becomes too great to allow control of speed, load,

¹⁶ Mobil EF-411 oil is a product of Mobil Oil Corp., 3225 Gallows, Fairfax, VA 22037.

and air-fuel ratio during Stage 3, discard the throttle body.

7.6.5 Intake Manifold:

7.6.5.1 The intake manifold is comprised of three parts: upper intake manifold, lower intake manifold, and intake manifold spacer. The spacer is necessary to allow the upper intake manifold to clear the RAC (see Fig. A3.20). The spacer can be purchased separately or as part of a kit of modified parts available from the supplier detailed in X2.1.13. Modify the intake manifold, as detailed in Fig. A3.21. Block the EGR valve port by means of a cover plate or pipe plug. Locate the PCV valve vacuum connection at the lower port on the upper intake manifold, as detailed in Fig. A3.21. Locate the intake manifold vacuum measurement, fuel pressure regulator, and manifold absolute pressure (MAP) sensor connections at the upper port on the upper intake manifold, as detailed in Fig. A3.21.

7.6.5.2 Disassemble and thoroughly clean the intake manifold before each test by soaking in a commercially available carburetor cleaner. This is followed by a hot (> 60°C) water rinse and forced air-drying. The intake manifold can be used in repeated builds.

7.6.6 Rocker Arm Cover:

7.6.6.1 Before each test, flush the RAC coolant jacket with a mixture of hot (> 60°C) water and tri-sodium phosphate detergent. After flushing, inspect the coolant jacket. If a deposit or film is present, clean the RAC coolant jacket with a commercially available de-scaling cleaner, neutralizer, and inhibitor (see 8.4.4.1). Examples of acceptable cleaners are detailed in 7.7.

7.6.6.2 Inspect the appearance of the interior surface of the RAC. If the before test rating is less than ten on the CRC varnish rating scale (Manual 14), polish the interior surface lightly with Number 0 fine steel wool to achieve a fine dull shine. Rinse the cover with aliphatic naphtha and allow to air-dry before use.

7.6.7 *Camshaft Baffle*—Polish the camshaft baffle with Number 0 fine steel wool to achieve a fine finish. Rinse with aliphatic naphtha and allow to air-dry before use.

7.6.8 *Oil Pan*—Inspect the appearance of the tin plating on the internal surface of the pan. Polish lightly with Number 0 fine steel wool to achieve a dull shine. Rinse with aliphatic naphtha and allow to air-dry before use. Replate the pan when the finish becomes unserviceable (see 7.4.6).

7.6.9 *PCV Valve*—Measure and record the flow rates of the PCV valves with the calibrated flow device described in 7.5.16 and Fig. A3.34. Measure the flow rate at 8 and 18-in. Hg (27 and 61-kPa) vacuum. Because of the hysteresis in the PCV valve spring, make the vacuum adjustments in one direction only. Measure the flow rate twice and average the readings. Reject any PCV valve that does not exhibit an average flow rate between 2.40 and 2.90 cfm (1.13 and 1.37 L/s) at 8 and 18-in. Hg vacuum.

7.6.10 *Water Pump Drive System*—Use only the pulleys provided in the Sequence VE Test Stand Set-Up Kit (see Table A4.2) to ensure that the water pump rotates at the proper speed.

7.6.11 Fuel Injectors:

7.6.11.1 Prior to engine installation, evaluate all injectors (new and used) for spray pattern and flow rate using a suitable

apparatus as identified in 7.5.18.5. The evaluation procedure is outlined in this section. Injectors may be cleaned and reused if the criteria outlined in this section are satisfied.

7.6.11.2 Flush new injectors for 30 s to remove any assembly residue before flow testing.

7.6.11.3 Using a rig as described in 7.5.18.5, place the injector(s) in the rig and turn on the pressure source. After the pressure source is turned on, the test fluid (see 7.7.1) will start to flow through the injector(s). Maintain the test fluid pressure supplied to the injector(s) at 39 ± 0.5 psi (269 ± 3.4 kPa) during the entire test. The maintenance of this pressure is critical because a small change in pressure will have a dramatic effect on the flow rate and spray pattern. Once pressure is set, zero the volume measuring device.

7.6.11.4 Apply pressure to the closed injector(s) for at least 30 s. The injector(s) shall not leak or drip. Replace any injector that leaks or drips.

7.6.11.5 Flow-test each injector for a 60-s period. While the injector is flowing, make a visual observation of the spray pattern quality. The spray pattern should be typical for the make and model of the injector.

7.6.11.6 The total flow for each injector after the 60 s test shall be between 3.7 oz (109 cm³) and 4.5 oz (134 cm³) at 39 ± 0.5 psi (269 ± 3.4 kPa) of test fluid pressure. Discard any injector that flows above or below this range.

7.7 *Solvents and Cleaners Required*—No substitutions for the following are allowed: (**Warning**—Use adequate safety provisions with all solvents and cleaners.)

7.7.1 *Aliphatic Naphtha*, Stoddard solvent¹⁷ or equivalent is satisfactory.

7.7.2 *Ethyl Acetate*.

7.7.3 *Organic Solvent*, Penmul L460¹⁸ or Oakite 811.¹⁹

7.7.3.1 Implement the specified gas chromatographic monitoring program (see Annex A10) when using Oakite 811 to prevent gelatinous-type coatings on water-rinsed parts.

7.7.4 *Pentane*.

7.7.5 *Tri-Sodium Phosphate Detergent*, cylinder block and RAC cleaning detergent.

7.7.6 *Formulation No. 7 Cooling System Cleaner—Heavy-Duty*,²⁰ cooling system flushing agent to engine cooling system cleanser consists of the following:

7.7.6.1 *Oxalic Acid Dihydrate Tech*.

7.7.6.2 *Alkylated Naphthalene, Sodium Salt*—Petro Dispersant 425 (soap).

7.7.6.3 *Soda Ash Light*—(Neutralization).

7.7.7 *Dearsol 134 Acidic Cleaner with Inhibitor*, (or equivalent). RAC cooling system cleaner.

7.7.8 *Commercial solvent*, designated for cleaning carburetors.

7.8 *Assembling the Test Engine—Preparations*—Functions that are to be performed in a specific manner or at a specific

¹⁷ Stoddard Solvent is a product of UNOCAL Chemicals Division, 7010 Mykawa St., Houston, TX 77033.

¹⁸ Penetone L460 is a product of Penetone Corp., P.O. Box 22006, Los Angeles, CA 90022.

¹⁹ Oakite 811 is a product of Oakite Products, 10100 Hirsch, Houston, TX 77016.

²⁰ Formulation No. 7 Cooling System Cleaner—Heavy-Duty is a product of Armor All, Department 2224, SCF, Pasadena, CA 91051.

time in the assembly process are noted. Any assembly instructions not detailed as follows should be completed in accordance with the instructions in Footnote 14.

7.8.1 *Parts Selection*—Instructions concerning the use of new or used parts are detailed in 7.1.1, 7.2, and 7.3.

7.8.2 *Engine Measurement Records*—Record the engine measurements on data sheets equivalent to those shown in Appendix X1.

7.8.3 *Buildup Lubrication*—Lubricate all engine parts with EF-411 oil during assembly.

7.8.4 *Sealing Compounds*—No specific compounds required.

NOTE 3—Silicone-based sealers should be used with care since they can elevate the indicated silicon content of the used oil. Also use tape sealers with care because tape fragments can plug oil orifices in the oiling system.

7.8.5 *Gaskets and Seals*—Use new gaskets and seals at all locations during each engine assembly.

7.8.6 *Cylinder Head*:

7.8.6.1 *Cleaning*—Rifle-brush cylinder head guides with a valve guide brush and aliphatic naphtha. Remove the end plugs of the camshaft and rifle-brush the central gallery with a valve guide brush and aliphatic naphtha. Rinse with aliphatic naphtha and air-dry with compressed air. Reinstall the camshaft end plugs after the air-drying.

7.8.6.2 *Valve Guides*—Measure and record the valve stem-to-guide clearance for each valve (see 7.5.7). The clearances shall be within the following specifications: exhaust at 0.0019 to 0.0032 in. (0.048 to 0.081 mm) and intake at 0.0014 to 0.0027 in. (0.036 to 0.069 mm). The clearances can be adjusted by selectively fitting valves or reaming the valve guides.

7.8.6.3 *Camshaft Bearings*—Inspect the bearings for any anomalies and ensure the bearing holes are properly aligned with the oil gallery in the Number 2 and 3 pedestals. Tap the 0.237-in. (6.02-mm) holes in the top of the pedestals to receive the cam baffle hold-down bolts (see Fig. A3.24). While Fig. A3.24 shows that 5/16-in. (8-mm) machine screws are satisfactory for this purpose, experience has shown that 7-mm machine screws may be a preferred alternative.

7.8.6.4 *Camshaft*: Install 1992 VF kit cams, part no. E59E-6251-DA, serial numbers 920160 through 922882 (available October 31, 1993) for all reference oil tests and associated non-reference oil tests starting on or after October 1, 1994.

(a) *Lobe Height and Lift Measurement*—Measure and record the heel-to-toe dimension of each camshaft lobe at the maximum lift point and at a plane perpendicular to the maximum lift point. Subtract the value taken perpendicular to the maximum lift point from the heel-to-toe value. This difference is the camshaft lift. Reject any cam that exhibits a lift value that does not fall between 0.2367 and 0.2391 in. (6.012 and 6.073 mm). Note that the *before test* heel-to-toe dimension is also used as the baseline measurement for determining wear (see 13.6.1). Record the actual values for both measurements in the appropriate spaces of the form in Fig. X1.3.

(b) *Lobe Hardness Measurement*—Measure and record the lobe hardness 180° from the maximum lift point and approximately 0.05 in. (1.3 mm) from the forward edge of each lobe. Include the individual cam lobe hardness measurements on the

hardness measurement data sheet (see Fig. X1.4).

(c) *Oil Groove Measurements*—Measure and record the oil groove depth and width on the Number 2 and 3 journals. Calculate the nominal depth and width using the following equations:

$$\text{nominal groove depth} = \frac{G + D}{2} \quad (1)$$

where:

G = maximum groove depth, and

D = minimum groove depth.

$$\text{nominal groove width} = \frac{E + R}{2} \quad (2)$$

where:

E = maximum groove width, and

R = minimum groove width.

The nominal oil groove depth shall be between 0.039 and 0.047 in. (0.99 and 1.19 mm), and the nominal oil groove width shall be between 0.052 and 0.063 in. (1.32 and 1.60 mm). The grooves can be machined to bring the dimensions within the specifications. Reject any camshaft that cannot be modified to achieve these specifications.

7.8.6.5 *Lobe Hole Measurements*—Measure and record the lobe hole diameter on each lobe. The lobe hole diameters shall be between 0.047 and 0.055 in. (1.19 and 1.40 mm). The holes can be drilled to bring the diameters within the specification. Reject any camshaft that cannot be modified to achieve this specification.

7.8.6.6 *Journal Through-Hole Measurements*—Measure and record the journal through-hole diameter of the Number 2 and 3 journals. The journal through-holes shall be between 0.116 and 0.124 in. (2.95 and 3.15 mm). The holes can be drilled to bring the diameters within the specification. Reject any camshaft that cannot be modified to achieve this specification.

NOTE 4—The axis of the journal through-hole is not perpendicular to the centerline of the camshaft.

7.8.7 *Rocker Arms*—Clean each rocker arm with ethyl acetate and allow the rocker arm to air-dry before taking any measurements. Measure and record the hardness and weight of each rocker arm. The hardness is measured on the cam lobe mating surface toward the fulcrum end of the rocker arm. The measurement shall be within 0.100 in. (2.5 mm) of the edge of the camshaft mating surface and near the centerline of the rocker arm. Reject any rocker arm that exhibits a hardness less than 57 HRC. A special holding fixture for the rocker arm is required for hardness measurements (see 7.5.1).

7.8.8 *Valve Springs*:

7.8.8.1 *Free Length*—The valve spring free length should be between 1.9 and 2.0 in. (48.3 to 50.8 mm).

7.8.8.2 *Out-of-Square*—The valve spring out-of-squareness should be 0.075 in. (1.91 mm) maximum.

7.8.8.3 *Load*—If the springs are within the free length and out-of-square specifications, then measure the load in the unassembled valve spring calibration device (see 7.5.5). This should be 167 ± 8 lbf at 1.16 ± 0.03 -in. (740 ± 20 N at 29.5 ± 0.8 -mm) deflection.

7.8.8.4 *Installation*—Lubricate each valve seal and valve stem with EF-411 oil. Install the valve seal over the end of the valve stem with a plastic installation cap in place. Carefully seat the seals fully on the guides. Install prescreened valve springs and retainers. When installing the valve springs and retainers, do not compress the springs excessively. Excessive spring compression can damage the valve seals. Measure and record the assembled height of the valve springs in accordance with the procedure described in Footnote 15. The assembled height shall be between 1.53 and 1.59 in. (38.8 and 40.4 mm).

7.8.8.5 *Calibration:*

(a) Check calibration of fixture load cell. Verify within procedure limits. Make calibration adjustments as required to achieve + 0.4 lb (+ 1.8 N) accuracy.

(b) Check head support fixture for correct setup for the VE cylinder head.

(c) Place VE cylinder head in holding fixture with intake valve springs accessible.

(d) Position air cylinder/load cell to allow compressing intake valve spring No. 1 (far left).

(e) Position dial indicator with plunger on rocker cover gasket rail (see Fig. A3.47).

(f) With zero air pressure to air cylinder, position the dial indicator to achieve exactly 0.100-in. (2.54-mm) deflection preload against the rocker cover rail. This allows determination of positive or negative displacement of the valve.

(g) Actuate the air cylinder in a rapid consistent manner to compress the intake valve spring.

(h) Adjust air regulator to achieve exactly 0.400-in. (10.16-mm) valve spring compression. This is indicated as 0.500 in. (12.70 mm) on the dial indicator.

(i) Discharge the air cylinder in a consistent manner and allow intake valve to close to the fully seated position. The dial indicator should read 0.100 in. (2.54 mm) (zero valve displacement).

(j) If the dial indicator did not accurately repeat 0.100 + 0.001-in. (2.54 + 0.02-mm) reading, conduct steps (f) through (i) and adjust the dial indicator as necessary to achieve accurate repeatability of indicated seated and displaced valve positions (0.100 in. and 0.500 in.).

(k) If the dial indicator accurately repeated the desired value, actuate and discharge the air cylinder three additional times and verify repeatability of the indicated valve positions.

(l) Open air valve to compress valve spring to the displaced position.

(m) Record indicated force (lb).

(n) Position air cylinder/load cell to check remaining three intake valve springs. Conduct steps (e) through (m) for each remaining intake valve spring.

(o) Position cylinder head in fixture with exhaust valve springs accessible. Conduct steps (e) through (m) for each exhaust valve spring.

(p) Replace any springs requiring applied force less than 159 lb (707 N) or more than 175 lb (778.4 N). Recheck spring calibration and record compressed force of any replaced springs (see steps d through m).

7.8.9 *Short (Cylinder) Block*—Use the 1992 VF cylinder block (1992 VF cylinder block, part number F37E-6010-AB, is

available for use October 31, 1993) for all reference oil tests and associated non-reference oil tests starting on or after October 1, 1994.

7.8.9.1 *Initial Preparation*—Disassemble the short block and remove all gallery plugs and freeze plugs. Reinstall the main bearing caps and torque them to 85 ± 5 lbf·ft (115 ± 7 N·m). Inspect the coolant jacket to ensure the coolant passages are reasonably free of casting slag. Remove the external oil separator on the left side of the crankcase. Plug the hole with a 1/2-in. NPT pipe plug. Remove the internal sheet metal baffle located inside the block, underneath the oil separator passage. Tap the dipstick tube hole to accept a 1/8-in. NPT pipe nipple (see 7.4.4). Tap the monolithic timing port to accept a 3/8-in. NPT pipe (see 7.4.3).

7.8.9.2 *Cleaning*—Submerge the cylinder block in agitated organic solvent (see 7.7.3) until clean (approximately 1 h). Rinse the parts thoroughly with hot water ($> 60^\circ\text{C}$). Spray rinse with aliphatic naphtha and use compressed air to force air-drying. If the cylinder block is going to sit idle for an excessive period of time before honing, spray all parts with aliphatic naphtha containing 10 % EF-411 oil by volume. Perform final cylinder block cleaning and preparation after the block is honed and the pistons and rings are fitted.

7.8.9.3 *Honing:*

(a) Install a used head gasket between the block and the stress plate. Install the stress plates (see 7.5.9), main bearing caps, and water pump for honing and measurement of the cylinder bores and ring gaps. Use torque-to-yield bolts when installing the stress plates. Torque the head bolts in accordance with the sequence described in Footnote 14 in two stages, 55 ± 5 lbf·ft (75 ± 7 N·m) and an additional 90 to 100° clockwise rotation.

(b) Install the block in a honing machine. (Sunnen CK-10 or CV-616 honing machines have been found suitable. However, any honing machine capable of producing the desired cross-hatch pattern and cylinder microfinish can be used.) The appropriate Sunnen honing machine setups and honing stone selections are shown in Table 1. These speeds and stroke rates provide a cross-hatch pattern with a 30 or 40° maximum included angle. The selection of stones is optional as shown in Table 1.

(c) Experience has shown that two complete strokes with the rough stones are required to break up the bore glaze and prevent the finer stones from loading up with debris. Ten to fifteen strokes are required to obtain the desired cylinder microfinish. The honing lubricant shall not contain any excessive amount of honing debris.

(d) If the cylinder block has been used in a previous test, make sure all worn areas are eliminated during honing. If any worn areas are still present after honing, re-hone the cylinder block to the next larger size or discard the cylinder block.

7.8.9.4 *Surface Finish*—Measure the finish of each cylinder bore using a 0.030-in. (0.76-mm) cutoff on the profilometer. Record the typical finish measured at the top, middle, and bottom elevations of the bores. Calibrate the profilometer frequently.

7.8.9.5 *Bore Measurements:*

(a) Measure the cylinder bores with the stress plate and the

main bearing caps in place. Clean the bores with a dry rag until no further residue appears after wiping. The bores shall be clean and dry when they are measured. Use the bore ladder (see Fig. A3.38) and a bore gage micrometer to determine the diameter of each cylinder at the top, middle, and bottom of second compression ring travel in both the longitudinal and transverse directions.

(b) Record the bore diameters in 0.0001-in. increments over 3.7800 in. (0.003 mm over 96.010 mm). The cylinder bore out-of-roundness represents the difference between the longitudinal and transverse diameters. Calculate and record the out-of-round value for each second ring travel location. This value shall not exceed 0.0010 in. (0.025 mm) at any location.

(c) Calculate and record the cylinder bore taper value for each cylinder: this represents the difference between the largest and smallest diameter in a given cylinder bore. This value shall not exceed 0.0015 in. (0.038 mm) at any location. If the cylinder bore out-of-round, taper, and micro-finish are not within the specified tolerances, rehone the particular bore(s).

(d) After achieving the specified cylinder tolerances, calculate the average bore diameter for each cylinder using the middle and bottom transverse diameters. Record the average bore diameter and the calculated range of acceptable piston sizes that can be fitted in each bore. These data will be used when fitting pistons to specific cylinders.

NOTE 5—Final sizing of the cylinder bores depends on the pistons available for fitting.

7.8.9.6 *Final Preparations*—After honing, bore measurement, piston ring gap adjustments, and piston fitting, soak the block in agitated clean organic solvent (see 7.7.3) for 1 h. Rinse the block with a mixture of hot (> 60°C) water and tri-sodium phosphate detergent and flush out all oil and coolant passages until no residue appears. Final rinse with hot (60°C) water. Spray the block with aliphatic naphtha containing 10 % EF-411 oil by volume. Use compressed air to force air-drying. (**Warning**—Do not spray the aliphatic naphtha/EF-411 oil mixture into the coolant passages. Clear all passages with compressed air and wipe the cylinder bores with EF-411 oil.)

7.8.10 *Pistons:*

7.8.10.1 *Inspection of Tin Plating Quality*— Reject any pistons with tin plating that is peeling or flaking. Examine the skirt surfaces for discoloration. Remove any discoloration by rubbing the piston with a Scotch Brite²¹ 7445 pad. Reject any pistons from which discoloration cannot be removed.

7.8.10.2 *Oversizes*—Either of the piston oversizes included in the Sequence VE Test Engine Parts Kits, 0.2 or 0.5 mm, can be used. However, all pistons in a given engine shall be of the same nominal oversize. Tests starting after May 19, 1998, may use 0.5-mm pistons, modified in accordance with Annex A15

by C&F Tool and Die²² and inspected by Test Engineering, Inc.²³ Use pistons modified in accordance with Annex A15 for all tests started on or after December 31, 1998, with 0.5-mm oversize pistons.

7.8.10.3 *Measurement*—Measure and record the piston diameter at the wrist pin centerline elevation, perpendicular to the wrist pin centerline, and across the extended tips of the piston skirts. Use the wrist pin centerline diameter to determine the fitted clearance. Piston taper is the difference between the perpendicular centerline diameter and the skirt diameter. Positive piston taper means the skirt diameter is greater than the perpendicular centerline diameter. The taper shall be positive and shall not exceed 0.0015 in. (0.038 mm).

7.8.10.4 *Selection*—Select each piston to provide a calculated 0.0014 to 0.0022-in. (0.036 to 0.056-mm) clearance to its bore. (Alternatively, the cylinder bores can be honed to fit the pistons on hand.) Install the pistons in their respective bores to verify each piston is properly sized.

NOTE 6—Threading a feeler strip between the piston and the cylinder wall is a simple method to verify the piston-to-cylinder wall clearance. Remove the pistons for installation on the connecting rods.

7.8.11 *Piston Rings:*

7.8.11.1 *Selection*—Select the proper oversize piston rings to correspond with the nominal piston oversize. As an example, a 0.15-mm oversize ring corresponds with a 0.20-mm oversize piston, and a 0.45-mm oversize ring corresponds with a 0.50-mm oversize piston.

7.8.11.2 *Ring Gap Adjustment*—Enlarge both compression ring gaps on each piston-and-ring assembly to obtain the specified blowby flow rate. Ring gaps ranging from 0.048 to 0.096 in. (1.2 to 2.4 mm) have been used successfully in various laboratories. Any combination (wider or narrower top ring gap or second ring gap) is acceptable. Enlargement of the oil ring gaps is not necessary to achieve satisfactory control of the blowby flow rate.

(a) Position each ring in its respective cylinder with the ring positioner (see Fig. A3.37) so that the gaps are located at the center of the thrust side of the cylinder wall. Measure and record the ring gaps.

7.8.11.3 *Installation*—Remove burrs from the ring ends. Then, install the compression rings and the oil control rings on the pistons with the gaps located outside the skirt areas. The gaps should be staggered at approximately 180° intervals. The gaps should be located alternately toward the front and rear of the engine.

7.8.11.4 *Side Clearance*—Measurement of the ring side clearance is not required but can help prevent possible blowby flow rate control problems. The side clearance should be between 0.0010 and 0.0030 in. (0.025 and 0.075 mm).

²² The sole source of machining services known to the committee at this time is C&F Tool and Die, 7206 Eckhart Rd., San Antonio, TX 78238. If you are aware of alternative services, please provide this information to ASTM Headquarters. Your comments will receive careful consideration at a meeting of the responsible technical committee, which you may attend.

²³ The sole source of inspection services known to the committee at this time is Test Engineering, Inc., 12758 Cimarron Path, Ste. 102, San Antonio, TX 78224-3417. If you are aware of alternative services, please provide this information to ASTM Headquarters. Your comments will receive careful consideration at a meeting of the responsible technical committee, which you may attend.

²¹ The sole source of supply of Scotch Brite 7445 pads known to the committee at this time is 3M Abrasive Systems Division, 3M Center, Building 223-6N-01, St. Paul, MN 55144-1000 U.S.A. If you are aware of alternative suppliers, please provide this information to ASTM Headquarters. Your comments will receive careful consideration at a meeting of the responsible technical committee, which you may attend.

7.8.12 *Connecting Rods*—Measure and record the big end oil orifice diameter. The orifice diameter shall be from 0.062 to 0.068 in. (1.57 to 1.72 mm). The orifice can be drilled to achieve the specified diameter.

7.8.13 *Wrist Pins*—Heat the small end of the connecting rod in a connecting rod heater (see 7.5.8). Insert the wrist pin through the piston and rod by hand and center the pin on the connecting rod. Commercial connecting rod heaters have a fixture to ensure precise centering of the pin. (**Warning**—In addition to other precautions, use extreme care when working around the connecting rod heater and handling the heated rods.)

7.8.14 *Connecting Rod Bearings*—Mark position numbers on the connecting rod bearings. Rinse the bearings in aliphatic naphtha, then in pentane, and air-dry. Weigh and record the weights of each bearing half.

7.8.15 *Crankshaft*—Inspect the bearing journals carefully. Polish the journal surfaces with Number 320 or 400 grit crocus cloth and EF-411 buildup oil. Measure and record the journal diameters. The maximum journal out-of-roundness shall be between 0.0000 and 0.0006 in. (0.000 and 0.015 mm). Spray the crankshaft with aliphatic naphtha containing 10 % EF-411 oil by volume.

7.8.16 Modify the crankshaft ignition trigger by drilling out the rivets, tapping the holes to accept a machine screw, and relocate the hall effect ring to obtain 28° BTDC, at 750 r/min.

7.8.17 Modify the cylinder head drain holes in accordance with Fig. 2.

7.9 *Assembling the Test Engine—Installations:*

7.9.1 *Crankshaft and Miscellaneous Cylinder Block Components*—Install all oil gallery plugs. Remove the main bearing caps and install the main bearings in the cylinder block. Install the crankshaft and install the front cover. Install the main bearings in the main bearing caps and torque the main bearing caps to 85 ± 5 lbf·ft (115 ± 7 N·m). Install the front cover. Measure and record the main bearing clearances. The desired clearances are 0.0015 to 0.0020 in. (0.038 to 0.051 mm). The allowable clearances are 0.0008 to 0.0026 in. (0.020 to 0.066 mm).

7.9.2 *Auxiliary Shaft Drive*—Install the auxiliary shaft and the auxiliary shaft drive sprocket. Install a petcock with a provision for a drain hose on the right side of the block at the existing drain plug location.

7.9.3 *Pistons*—Install the pistons in the correct cylinder bores. Measure and record the rod bearing clearances. The desired clearances are 0.0015 to 0.0020 in. (0.038 to 0.051 mm). The allowable clearances are 0.0008 to 0.0026 in. (0.020 to 0.066 mm) for connecting rod and crankshaft main bearings.

7.9.4 *Oil System Components*—Install the oil pump, the oil pump pickup tube and screen assembly, and the oil pan.

7.9.5 *Cylinder Head*—Install the cylinder head on the cylinder block. Use new torque-to-yield cylinder head bolts. Do not use any sealing or anti-seizure compound on the cylinder head gasket. Lubricate the head bolts with EF-411 oil. Torque the head bolts in accordance with the sequence described in Footnote 14 in two stages: 55 ± 5 lbf·ft (75 ± 7 N·m) and an additional 90 to 100° clockwise rotation.

7.9.6 *Camshaft and Related Components:*

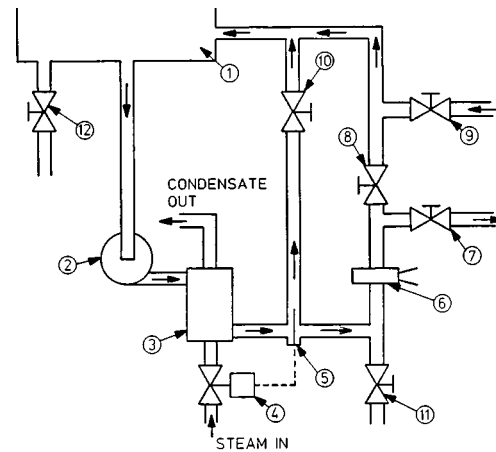

- ① MIXING TANK.
- ② ELECTRIC PUMP.
- ③ STEAM HEAT EXCHANGER.
- ④ PROCESS STEAM CONTROL VALVE
- ⑤ SYSTEM TEMPERATURE CONTROL SENSOR
- ⑥ FLOWMETER.
- ⑦ OUTLET VALVE (TO ENGINE).
- ⑧ RECIRCULATION VALVE.
- ⑨ INLET VALVE (FROM ENGINE).
- ⑩ BYPASS VALVE.
- ⑪ DRAIN VALVE.
- ⑫ DRAIN VALVE.

FIG. 2 Schematic of Typical Engine Cooling System Flushing Cart

7.9.6.1 Install the camshaft.

7.9.6.2 Do not remove the oil in the new lifters. Fill the lifters with EF-411 using the lifter fill chamber, Part No. BX-390-1. This lifter fill chamber is available from the supplier shown in X2.1.13.

(a) *Lifter Fill Chamber Operation*—Install lifters in the lifter holding fixture in an upright position. Add sufficient quantities of EF-411 to cover lifters. One litre has proven satisfactory. Close chamber, start vacuum pump, and hold vacuum for 10 min. Maintain 15–20 in. Hg (381–508 mm) vacuum throughout filling. Release vacuum, open chamber, raise holding fixture, and allow lifters to drain for 10 min. in upright position. Coat the lifter bodies with buildup oil prior to installation. Replace buildup oil in lifter chamber after filling three sets of lifters. Install the lifters in the cylinder head.

7.9.6.3 Install 1995 kit rocker arms, using Ford service tool, Part No. T74P-6565A. Install the camshaft drive sprocket, and measure and record the camshaft end-float.

7.9.6.4 Install the auxiliary shaft sprocket and align the cam drive. Torque the sprockets in accordance with the procedure noted in Footnote 14. Install a new camshaft drive belt. Tension the camshaft drive belt in accordance with the procedure noted in Footnote 14. Sealer may be required on the camshaft drive sprocket bolts if they have been used before.

7.9.6.5 Install the camshaft baffle and check to ensure the camshaft baffle does not come in contact with the RAC interior

surfaces. The correct mounting orientation of the baffle is shown in Fig. A3.24.

7.9.7 Rocker Arm Cover—Install.

7.9.8 Water Pump, Water Pump Drive, and Crankshaft Ignition-Trigger—Install modified crankshaft trigger, the water pump, and the water pump and crankshaft pulleys (part numbers E9TZ6312A and E69Z8509D) or FZZZ6312A and F27A8509BA. Install the camshaft drive belt cover.

7.9.9 Miscellaneous Parts—Install the intake manifold and insert the spacer between the upper and lower half of the intake manifold. Install the freeze plugs.

NOTE 7—Alternatively, the intake manifold and freeze plugs can be installed after the engine is installed on the test stand.

7.10 Engine Installation on the Test Stand—Functions that are to be performed in a specific manner or at a specific time in the assembly process are noted.

7.10.1 Mounting the Engine on the Test Stand—Mount the engine on the test stand so that the flywheel friction face is $4.0 \pm 0.5^\circ$ from vertical, with the front of the engine higher than the rear. The engine mounting system should be designed to minimize engine vibration at 750 and 2500 rpm (80 and 260 rad/s). Couple the engine directly to the dynamometer through a driveshaft. The engine cannot be used to drive any external engine accessory other than the water pump.

7.10.2 Flywheel Timing Index Calibration— If ignition timing is measured at the flywheel, calibrate the position of the flywheel index pointer to TDC of the number one cylinder (see 7.5.17) (**Warning**—A significant amount of backward crankshaft rotation can cause the timing belt to jump time because of the arrangement of the belt tensioner.)

7.10.3 Exhaust Manifold:

7.10.3.1 Installation—Install the required water-cooled exhaust manifold shown in Fig. A3.8 and Fig. 3 (see supplier listed in X2.1.7).

7.10.3.2 Gas Sampling and Back-Pressure Measurement Fittings:

(a) The required fitting for exhaust gas sampling and back-pressure measurement is illustrated in Fig. 3 and detailed in A3.5.

(b) Install the exhaust gas sample and exhaust back-pressure probes. Check all exhaust system connections to ensure they are secure.

(c) The exhaust back pressure/exhaust gas sample probes can be used until they become unserviceable. If the existing probes are not cracked, brittle, or deformed, clean the outer surface and clear all port holes. Check the probes for possible internal obstruction and reinstall the probes in the exhaust pipe. Stainless steel probes are generally serviceable for several tests; mild steel probes tend to become brittle after one test. (**Warning**—Exhaust gas is noxious.) (**Warning**—Any leaks in the connections to the sample probe will result in erroneous O₂ readings and incorrect air-fuel ratio adjustment.)

7.10.4 Fuel Management System:

7.10.4.1 Fuel Rail Assembly:

(a) The fuel injectors may be used for several tests, provided the spray pattern and flow rate are checked (see 7.6.11). There is currently no specified life of the fuel injectors. Use only fuel injectors that have demonstrated flow rates of 3.7

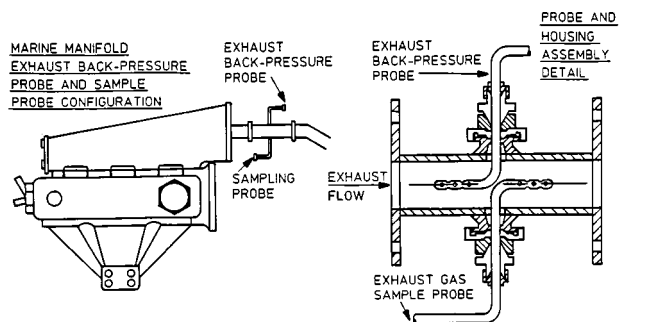

NOTE
THE EXHAUST BACK-PRESSURE AND SAMPLE PROBES MAY BE POSITIONED AT ANY ANGLE AROUND THE CIRCUMFERENCE OF THE HOUSING, PROVIDED:-
1. THE EXHAUST BACK-PRESSURE PROBE IS POSITIONED UPSTREAM AND THE EXHAUST GAS SAMPLE PROBE IS POSITIONED DOWNSTREAM
2. THE PROBE IS COINCIDENT WITH THE PIPE

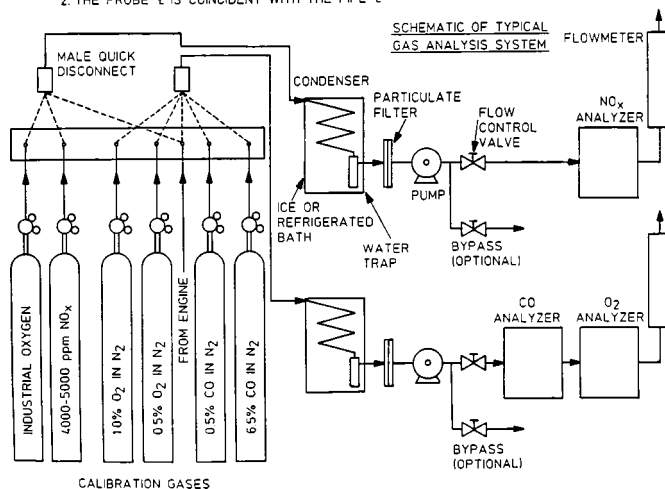

FIG. 3 Exhaust System and Exhaust Gas Analysis Apparatus

to 4.5 oz (109 to 134 cm³) at 39 ± 0.5 psi (269 ± 3.4 kPa) for 60 s.

(b) Inspect the O-rings to ensure they are in good condition and will not allow air leaks. Install the fuel injectors into the fuel rail and into the lower intake manifold. Connect the wiring harness to the fuel injectors. The injectors should be paired so that Cylinders 1 and 4 and 2 and 3 are in parallel (see 7.10.4.2).

7.10.4.2 Injector Pulsing:

(a) The fuel injectors are pulsed in alternating pairs, the pairs consisting of Cylinders 1 and 4 and 2 and 3 respectively. A schematic diagram of the necessary external connections to the injector wiring harness is shown in Fig. A3.44. Each injector pair is pulsed once per crankshaft revolution, without respect to crankshaft position. Typical pulse widths measured on the Ford EEC-IV system are described in the following section. A drawing showing what a pulse width represents is shown in Fig. A3.45. The pulse widths will vary slightly from engine-to-engine, although they should remain consistent for a given engine at a given fuel pressure. The measurement of fuel injector pulse widths is not required, although the measurement is a useful diagnostic tool.

(b) Typical fuel injector pulse widths for Stage 1 are 7.000 to 7.500 ms (approximately 38-psig [262-kPa] fuel pressure), for Stage 2 are 6.700 to 7.200 ms (approximately 38-psig [262-kPa] fuel pressure), and for Stage 3 are 2.500 to 3.500 ms (approximately 30-psig [207-kPa] fuel pressure). (The test stages are detailed in Table 2.)

TABLE 2 Operating Specifications

Item	Controlled Parameter ^A	Stage		
		1	2	3
Stage length	min	120	75	45
Engine speed	r/min	2500 ± 10	2500 ± 10	750 ± 25
Engine load	bhp	33.5 ± 0.5	33.5 ± 0.5	1.0 ± 0.5
Engine oil—Engine inlet temperature	°F	155 ± 2	210 ± 2	115 ± 2
Delta T (outlet-inlet)	°F	Record	Record	Record
Pump pressure	psig	Record	Record	Record
Engine gallery pressure	psig	Record	Record	Record
Delta P (pump-engine gall.)	psi	Record	15 max ^B	Record
Head gallery pressure	psig	Record	Record	Record
Delta P (engine gall-head)	psi	Record	Record	Record
Engine coolant—Engine out. temperature	°F	125 ± 2	185 ± 2	115 ± 2
Delta T (out.-inlet)	°F	Record	Record	Record
Flow rate	gal/min	15.0 ± 0.5	Record	...
Pressure	psig	10 ± 1	10 ± 1	10 ± 1
Marine manifold outlet temperature	°F	Record	Record	Record
RAC coolant—Inlet temperature	°F	85 ± 2	185 ± 2	85 ± 2
Flow rate	gal/min	2.0 ± 2	Record	2.0 ± 2
Intake air—Temperature	°F	90 ± 2	90 ± 2	90 ± 5
Specific humidity	grains/lb	80 ± 5	80 ± 5	80 ± 5
Pressure	in. H ₂ O gage	0.2 ± 0.1	0.2 ± 0.1	0.2 ± 0.1
Engine breathing—Corrected blowby flow rate	cfm	2.00 ± 0.25
Crankcase pressure	in. H ₂ O gage	Record	Record	Record
Intake manifold vacuum ^C	in. Hg gage	8 to 11	8 to 11	Record
Exhaust back pressure	in. Hg abs.	30.6 ± 0.3, - 0.2	30.6 ± 0.3, - 0.2	Record
Ignition—Timing	°BTDC	27 ± 1	27 ± 1	28 ± 1
Fueling—Consumption rate ^D	lb/h	Record	Record	Record
Pressure ^E	psig	Record	Record	Record
Exhaust gas analysis	O ₂	1.1 ^F	1.1 ^F	0.7 max
	CO	0.4 max ^G	0.4 max ^G	6.5 ± 0.5
	NO _x ,ppm	...	Record	...

^A Maintain all parameters as close to midrange values as possible.

^B This specification only applies to Cycles 1 through 6.

^C Manifold vacuum is used as a diagnostics tool rather than a control parameter.

^D The fuel consumption rate shall be maintained below 18 lb/h at all times during the test.

^E Fuel pressure should be constant at a given operating condition and between 27 and 40 psig.

^F Target value is 1.1 %. Lower limit is 0.8 %. Upper limit 1.2 %.

^G The maximum individual reading should be below 0.7 %. The maximum average value should be below 0.4 %.

7.10.4.3 Different Methods Currently Used:

(a) The fuel management controller hardware is not specified. The fuel management methods currently in use can be divided into five basic types of systems; modified Ford EEC-IV, open-loop analog, open-loop digital, closed-loop analog, and closed-loop digital. Process flow diagrams of typical open-loop and closed-loop digital systems are detailed in Fig. A3.22 and Fig. A3.23. Whatever fuel management system is used, there are specific ramping performance requirements (see 12.2.3.2). *Use adequate precautions to ensure the fuel injectors cannot function while the engine is shut down. In addition, design the fuel management system to prevent excessive fuel input during engine startup.*

(b) Exercise great care in the design, manufacture, and operation of the fuel management system to ensure that lambda is properly controlled throughout the test. It is recommended that the laboratory utilize the modified Ford EEC-IV system or an analog or digital system available from the suppliers detailed in X2.1.14.

7.10.5 Ignition System:

7.10.5.1 *Components*—Modifications to the ignition system are required. Modify the wiring harness by removing all circular connectors, except for the crankshaft ignition trigger connection. Figure A3.49 shows the required distributorless ignition system connections.

7.10.5.2 *Spark Plugs*—Install new Motorcraft AWSF-44 or

AWSF-44C²⁴ spark plugs that have been gapped to between 0.042 and 0.046 in. (1.07 and 1.17 mm). Torque the spark plugs to between 5 and 10 lbf-ft (7 and 14 N-m). Install the spark plug wiring harness but do not install the distributor and ignition module at this time.

7.10.6 Crankcase Ventilation System:

7.10.6.1 *Oil Separator*—Cut the 1.25-in. (31.8-mm) inside diameter polyethylene hose to approximately 1.5-in. (38-mm) length and install the oil separator on the front of the RAC. Maintain the distance between the bottom of the separator adaptor (Item 4, Fig. A3.16) and the top of the RAC at 5.5 ± 0.25 in. (139.7 ± 6.4 mm) (see Fig. A3.15). The alignment of the oil separator with the RAC should provide a straight run with no offset (see Fig. A3.15 and Fig. A3.17). Maintain the separator assembly in a vertical position throughout the test. A bracket may be necessary to support the separator.

7.10.6.2 *PCV Valve*—Install clean hoses and a new, calibrated PCV valve as shown in Fig. A3.15 and Fig. A3.17. Use the elbow provided with the PCV valve to attach the 0.375-in. (9.53-mm) inside diameter hose. Attach a new 0.375-in. inside diameter hose to the three-way valve for each test. Maintain the PCV valve in a vertical position throughout the test.

²⁴ Motorcraft AWSF-44 and AWSF-44C spark plugs are products of Ford Distribution Center, 11871 Middleton Belt, Levonia, MI 48150.

TABLE 2 (M) Sequence VE Operating Specifications (continued)

Parameter ^A	Stage			
	1	2	3	
Time	Stage length, min	120	75	45
Engine Loading	Engine speed, r/min	2500 ± 10	2500 ± 10	750 ± 25
	Engine power, kW	25.00 ± 0.37	25.00 ± 0.37	0.75 ± 0.37
Engine Oil	Engine inlet temperature, °C	68.3 ± 1.1	98.9 ± 1.1	46.1 ± 1.1
	Delta T (outlet-inlet), °C	Record	Record	Record
	Pump pressure, kPa	Record	Record	Record
	Engine gallery pressure, kPa	Record	Record	Record
	Delta P (pump-engine), kPa	Record	103.4 max ^B	Record
	Head gallery pressure, kPa	Record	Record	Record
	Delta P (engine-head), kPa	Record	Record	Record
Engine Coolants	Engine outlet temperature, °C	51.7 ± 1.1	85.0 ± 1.1	46.1 ± 1.1
	Delta T (outlet-inlet), °C	Record	Record	Record
	Flow rate, L/min	56.8 ± 1.9	Record	...
	Marine manifold outlet temperature, °C	Record	Record	Record
RAC Coolant	Inlet temperature, °C	29.4 ± 1.1	85.0 ± 1.1	29.4 ± 1.1
	Flow rate, L/min	7.6 ± 0.7	Record	7.6 ± 0.7
Intake Air	Temperature, °C	32.2 ± 1.1	32.2 ± 1.1	32.2 ± 2.8
	Specific humidity, g/kg	11.43 ± 0.71	11.43 ± 0.71	11.43 ± 0.71
	Pressure, Pa	50 ± 25	50 ± 25	50 ± 25
Engine Breathing	Corrected blowby flow rate, L/min	56.6 ± 7.1
	Crankcase pressure, Pa	Record	Record	Record
	Intake manifold vacuum ^C , kPa	24 to 34	24 to 34	Record
	Exhaust backpressure, Abs kPa	104 to 0.68, + 1.66	104 to 0.068, + 1.00	Record
Ignition and Fueling	Ignition timing, °BTDC	28 ± 1	28 ± 1	28 ± 1
	Fuel consumption rate ^D , kg/h	Record	Record	Record
	Fuel pressure ^E , kPa	Record	Record	Record
Exhaust Gas Analysis	O ₂ , %	1.1 to 0.3, + 0.1	1.1 to 0.3, + 0.1	0.7 max
	CO, %	0.4 max ^F	0.4 max ^F	6.5 ± 0.5
	NOx, ppm	...	Record	...

^A Maintain all parameters as close to midrange values as possible.

^B This specification only applies to Cycles 1 through 6.

^C Manifold vacuum is used as a diagnostics tool rather than a control parameter.

^D The fuel consumption rate must be maintained below 8.2 g-hr at all times during the test.

^E The maximum individual reading should be below 0.7 %. The maximum average should be below 0.4 %.

^F Fuel pressure should be constant at a given operating condition and between 186 and 276 kPa.

7.10.6.3 *Air Horn Adapter*—Install a clean 0.625-in. (15.88-mm) inside diameter transparent hose to the air horn adapter (use new hose when the existing hose appears deteriorated).

7.10.6.4 *Three-Way Valve*—Install a clean three-way valve and attach the PCV valve hose. Install the remaining PCV valve hose between the three-way valve and the upper intake manifold (see Fig. A3.15). Do not allow the hose to flatten at the bend after installation.

7.10.6.5 *Inspection*—When the installation of the crankcase ventilation system is complete, inspect the system to ensure the configuration will allow all oil condensate to drain to the elbow underneath the upper intake manifold. The pipe elbow leading to the intake manifold should be the lowest point of the system.

7.10.7 *Dipstick and Oil Fill Tubes*—Install the dipstick tube into the port on the left-hand side of the engine. Install the oil fill tube in the monolithic timing port on the left side of the engine (see 7.4.3 and 7.4.4).

7.10.8 *Intake Air Components*—Install the throttle body and intake-air horn.

7.10.9 *External Hose Replacement*—Inspect all external hoses used on the test stand and replace any hoses that have become unserviceable. Check for internal wall separations that could cause flow restrictions. Check all connections to ensure security.

8. Engine Fluids—Supply/Discharge Systems

8.1 Intake Air:

8.1.1 *Capacity*—The supply system shall be capable of

delivering 80 scfm (38 L/s) of conditioned air, while maintaining the intake-air parameters detailed in Table 3. A typical intake air duct is shown in Fig. 1 (also see Fig. A3.3 and Fig. A3.4).

8.1.2 *Dew Point*—The dew point can be measured in the main system duct or at the test stand (X2.1.9 lists suppliers of

TABLE 3 Phillips J Fuel Analysis

Parameter	Tolerance (±)
API gravity ^A	0.5
RVP ^B	1.0 psig (6.9 kPa)
Total sulfur ^C	0.01 g/gal (0.003 g/L)
Existent gum ^D	1.0 mg/100 mL
Distillation ^E	
IBP	16°F (8.8°C)
10 %	10°F (5.6°C)
50 %	11°F (6.1°C)
90 %	8°F (4.4°C)
EP	19°F (10.6°C)
The following parameters are analyzed on an absolute basis:	
Color	clear
Water	trace
Lead ^F	less than 0.01 g/gal (0.003 g/L)
Oxidation stability ^G	...

^A In accordance with Test Method D 287.

^B In accordance with Test Method D 323 or Automatic Reid Vapor Pressure Analyzer.

^C In accordance with Test Method D 1266.

^D In accordance with Test Method D 381.

^E In accordance with Test Method D 86.

^F In accordance with Test Method D 3237.

^G In accordance with Test Method D 525.

suitable instruments). If the dew point is measured in the main system duct, verify the dew point periodically at the test stand. Maintain the duct surface temperature above the dew point temperature at all points downstream of the humidity measurement point to prevent condensation and loss of humidity level.

8.1.3 *Filtration*—Since no air filtration is provided at the intake-air horn, the supply system shall provide either water-washed or filtered air to the duct. The filtration system shall have sufficient flow capacity to maintain the specified intake-air pressure.

8.2 *Fuel:*

8.2.1 *Description*—A schematic diagram of a typical fuel supply system is shown in Fig. 4. Supply an excess volume of fuel to the fuel rail at all times. Introduce make-up fuel (fuel used by the engine) into the loop from an external source. Mix the make-up fuel with fuel that is returned from the fuel rail (fuel not used by the engine). Pump the fuel through a mixing chamber, or small heat exchanger, which is used to mix the two streams and provide fuel of consistent temperature to the engine. Deliver the fuel to a high-pressure pump, which boosts the pressure and supplies the fuel to the fuel rail.

8.2.2 *Controls*—Maintain the fuel temperature below the initial boiling point of Phillips J²⁵ fuel. To ensure good atomization of the fuel, maintain the fuel pressure above 27 psig (186 kPa). In addition, the fuel pressure should be constant at all steady-state conditions to ensure good speed, power, and air-fuel ratio control.

8.2.3 *Fuel Volume Required*—Approximately 630 gal (2385 L) of Phillips J reference unleaded gasoline are required for each test.

8.2.4 *Fuel Batch Approval Process*—Each new batch of fuel is approved by the following process:

²⁵ Phillips “J” reference gasoline is a product of Phillips Chemical Co. Speciality Chemicals, P.O. Box 968, Borger, TX 79008. For general information about Phillips “J” fuel, see X2.6.

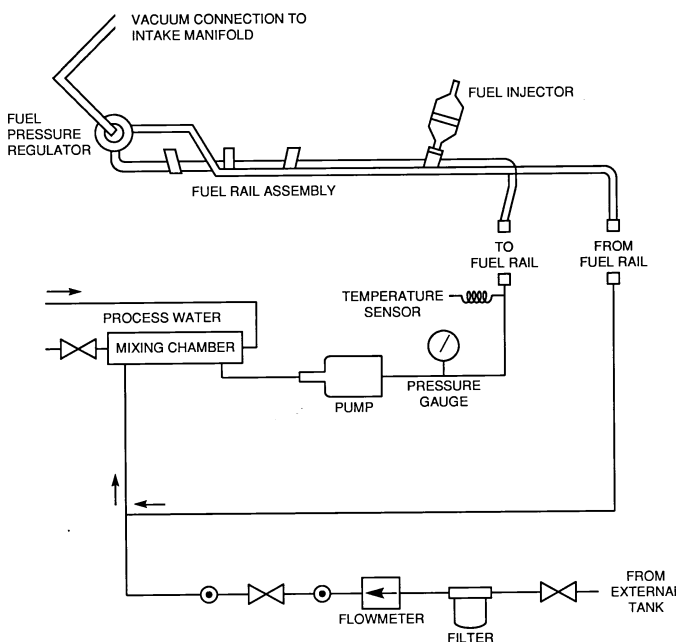

FIG. 4 Schematic of Engine Fuel System

8.2.4.1 Before initial blending, each of the four fuel components is analyzed, and the data are compared with predetermined physical specifications. A small amount of fuel mixture is then blended, analyzed, and compared to predetermined specifications. The TMC determines the acceptability of the analytical data and authorizes blending of the entire batch for engine testing.

8.2.4.2 A sample of the fuel is shipped to two designated independent laboratories. A designed program involving more than one calibration test is completed using reference oils selected by the TMC. (The Sequence VE Reference Oils and Fuels Sub Panel, of Subcommittee B of ASTM Committee D-2, is involved in the design of the program.) The TMC reviews the test results and authorizes the fuel supplier to notify potential purchasers of the approval status of the fuel batch.

8.2.5 *Fuel Batch Analysis:*

8.2.5.1 Analyze each fuel shipment upon receipt from the supplier to determine the value of the parameters shown in Table 3 (except sulfur, oxidation stability, and distillation). Compare the results to the values obtained by the supplier on that particular batch. The results should be within the tolerances shown in parentheses beside each parameter. This provides a method to determine if the fuel batch is contained or has aged prematurely. If any results fall outside the tolerances shown in Table 3, the laboratory should contact the TMC for help in resolving the problem.

8.2.5.2 Analyze the contents of each fuel storage tank used for qualified Sequence VE tests every two months. Fuel in run tanks, those with a direct feed line to test engines, shall be analyzed monthly. It is recommended that laboratories take composite samples in accordance with Practice D 4057 as a guideline. Record on the fuel sample label the paragraph in Practice D 4057 that best describes the sampling method utilized. The fuel supplier provides an adequate supply of fuel sample containers with packaging and pre-addressed return labels to each Sequence VE laboratory. Upon receipt of fuel samples from the laboratory, the fuel supplier performs the following analyses, tabulates the results, and reports results to the submitting laboratory.

- | | |
|---------------------------------------|---------------------------------|
| Test Method D 323 Reid Vapor Pressure | Test Method D 381 Washed Gums |
| Test Method D 287 API Gravity | Test Method D 381 Unwashed Gums |
| Test Method D 86 Distillation | Test Method D 3606 Benzene |
| Test Method D 3237 Lead | (by way of Gas Chromatography) |

(a) In instances where results from the tests listed previously appear to vary significantly from the expected results, a second sample shall be analyzed or the following tests shall be conducted, or both:

- | |
|--|
| Test Method D 5134 Hydrocarbon Speciation (by way of Gas Chromatography) |
| Test Method D 525 Oxidation Stability |
| Test Method D 873 Potential Gums |

8.2.5.3 Forward the results of the analyses performed in 8.2.5.1 and 8.2.5.2 to the TMC for inclusion in the appropriate database.

8.2.6 *Fuel Batch Shipment and Storage*— Ship the fuel in containers with the minimum allowable venting as dictated by all safety and environmental regulations, especially when shipment times are anticipated to be longer than one week.

Store the fuel following all applicable safety and environmental regulations.

8.3 Engine Oil:

8.3.1 Non-Reference Test Oil Description:

8.3.1.1 The non-reference sample shall be uncontaminated and representative of the lubricant formulation being evaluated.

8.3.1.2 A minimum of 2.0 gal (7.6 L) of new oil is required to complete the test. A 5-gal (18.9-L) sample of new oil is normally provided to allow for inadvertent losses.

8.3.2 System Description:

8.3.2.1 Design the oil system to minimize stand-to-stand variations that could influence test severity. Control the oil flow rate and pressure drop by specifying the volume, plumbing configuration, and orientation of the heat exchanger. Specify the location of the heat exchanger only in a vertical plane. Configure the heat exchanger so that the process water and engine oil are in counter-flow. The lengths of the lines are not specified, but the line length and diameter have a large influence on the volume of the external system. The internal volume of the entire external system shall be 18 ± 3 oz (530 \pm 90 mL).

8.3.2.2 Configure the external oil system in accordance with the schematic diagrams and photographs shown in Figs. A3.10 through A3.13. Use the remote filter adapter OHTA-007-1 for tests started on or after September 1, 1996. This adapter is available from the supplier shown in X2.1.28. Typical volumes of the various components of the external oil system are detailed in Fig. A3.10. Install a new Motorcraft FL-300²⁶ oil filter on the external oil filter adapter as shown in Fig. A3.12. Be sure all hoses and fittings on the oil heat exchanger are properly connected and secure. *Do not use brass and copper fittings in the external oil system since they may influence used oil (wear metals) analysis.*

8.3.3 Heat Exchanger—The heat exchanger has been chosen to minimize the volume of the external system. The heat exchanger has adequate but not excessive capacity to control the oil temperature. The system requires a high level of maintenance to provide adequate cooling, especially when process water temperatures are high. An effective, well-maintained process water control system is necessary to achieve the specified oil temperatures. Carefully choose the controller and the system configuration to achieve proper response time, achieve the cyclic ramping specifications, and provide stable control at the three set points.

8.3.4 System Cleaning:

8.3.4.1 Clean the external oil cooling system thoroughly before each test. An acceptable technique for cleaning the oil heat exchanger is detailed in Annex A2. Flush and rinse the external lines before each test. The specific technique used (removed from or flushed on the stand, and so forth) is left to the discretion of the laboratory.

²⁶ Motorcraft FL-300 oil filter is a product of Ford Distribution Center, 11871 Middleton Belt, Levonia, MI 48150.

8.3.4.2 Regardless of the flushing technique employed, use an organic solvent (see 7.7.3) for the final flushing followed by separate rinses with hot ($> 60^{\circ}\text{C}$) water and aliphatic naphtha before air-drying the components. (**Warning**—Incomplete cleaning of the external oil system may allow debris to dislodge and circulate throughout the engine during subsequent tests. Incomplete cleaning may also cause oil temperature control problems and contaminate subsequent test oils.)

8.3.5 Engine Oil Pre-Lube Device—Turn the engine oil pump with a portable power source to fill the galleries with oil after engine reassembly. A modified distributor, without a cap, rotor, or gear, and a $\frac{3}{8}$ -in. (9.5-mm) electric drill are recommended to drive the oil pump.

8.3.6 Control Specifications—The oil inlet temperature and allowable oil pressure differential are specified in Table 2. Additional information concerning the oil pressure differentials is found in 12.5.6.2. Cyclic ramping specifications are detailed in Table 4.

8.4 Coolants:

8.4.1 Description—The engine and RAC coolant is a solution of demineralized (less than 2 grains/lb [0.034 g/kg]) or

TABLE 4 Sequence VE Test Ramping Requirements^A

Stage 3 to 1	
Engine speed	Attain 1600 r/min during 25–40 s Attain 2490 r/min during 55–75 s
Engine torque	7–20 lbf-ft at 50 s Attain 45 lbf-ft during 70–90 s Attain 65 lbf-ft during 85–105 s
CO	<10 % CO at 10 s 10–15 % CO at 30 s Attain 10 % CO during 60–85 s 12.7–15.3 % CO at peak of CO curve <5 % CO at 90 s
Oil inlet temperature	127–143°F at 5 min 153°F within 10 ± 2 min
Coolant outlet temperature	123°F within 4 min
Stage 1 to 2	
Oil inlet temperature	175–190°F at 6.5 min 208°F within 13 ± 2 min
Coolant outlet temperature	146–167°F at 4.5 min 183°F within 9 ± 2 min
Rocker arm cover inlet temperature	125–155°F at 6.5 min 183°F within 13 ± 2 min
Stage 2 to 3	
Engine speed	1500–1750 r/min at 55 s Attain 775 r/min during 105–125 s
Engine torque	Attain 45 lbf-ft during 10–30 s 7–20 lbf-ft at 55 s
CO	<1 % CO at –30 s 10.0–15.5 % CO at 35 s Attain 10.0 % CO during 50–75 s 13.0–15.5 % CO at peak of CO curve
Oil inlet temperature	149–177°F at 6.5 min 117°F within 13 ± 2 min
Coolant outlet temperature	131–169°F at 3.5 min 117°F within 7 ± 2 min
Rocker arm cover inlet temperature	125–145°F at 6.5 min >95°F at 10 min 87°F within 13 ± 2 min

^A Speed and torque should be linear between setpoint specifications. Fuel flow not to exceed 18 lb/h. Exhaust gas oxygen not to exceed 4 %. Fuel flow and exhaust gas oxygen are not required to be plotted.

TABLE 4 (M) Sequence VE Test Ramping Requirements^A
(continued)

Stage 3 to 1	
Engine speed	Attain 1600 r/min during 25–40 s Attain 2490 r/min during 55–75 s
Engine torque	7–20 lbf-ft at 50 s Attain 45 lbf-ft during 70–90 s Attain 65 lbf-ft during 85–105 s
CO	<10 % CO at 10 s 10–15 % CO at 30 s Attain 10 % CO during 60–85 s 12.7–15.3 % CO at peak of CO curve <5 % CO at 90 s
Oil inlet temperature	127–143°F at 5 min 153°F within 10 ± 2 min
Coolant outlet temperature	123°F within 4 min
Stage 1 to 2	
Oil inlet temperature	175–190°F at 6.5 min 208°F within 13 ± 2 min
Coolant outlet temperature	146–167°F at 4.5 min 183°F within 9 ± 2 min
Rocker arm cover inlet temperature	125–155°F at 6.5 min 183°F within 13 ± 2 min
Stage 2 to 3	
Engine speed	1500–1750 r/min at 55 s Attain 775 r/min during 105–125 s
Engine torque	Attain 45 lbf-ft during 10–30 s 7–20 lbf-ft at 55 s
CO	<1 % CO at –30 s 10.0–15.5 % CO at 35 s Attain 10.0 % CO during 50–75 s 13.0–15.5 % CO at peak of CO curve
Oil inlet temperature	149–177°F at 6.5 min 117°F within 13 ± 2 min
Coolant outlet temperature	131–169°F at 3.5 min 117°F within 7 ± 2 min
Rocker arm cover inlet temperature	125–145°F at 6.5 min >95°F at 10 min 87°F within 13 ± 2 min

^A Speed and torque should be linear between setpoint specifications. Fuel flow not to exceed 18 lb/h. Exhaust gas oxygen not to exceed 4 %. Fuel flow and exhaust gas oxygen are not required to be plotted.

distilled water and an additive treatment—16 oz (470 mL) (fluid) of Pencool 2000²⁷ per 4 gal (15 L) of water.

8.4.2 *General*—The following guidelines are common to both the engine and RAC coolant systems:

8.4.2.1 A transparent section is required to permit visual inspection of the coolant. Provide air blends to allow removal of entrained air. Provide a drain at the low point of the system to allow complete draining of the system.

8.4.2.2 Carefully choose the controller and the system configuration to achieve proper response time, achieve the cyclic ramping specifications, and provide stable control of the set points. An effective, well-maintained process water control system is necessary to achieve the specified coolant temperatures.

8.4.2.3 The system shall allow precise calibration of the flowmeters, after installation in the test stand. Avoid turbulence near the measurement meters and the flowmeters used for calibration.

²⁷ The sole source of supply of Pencool 2000 known to the committee at this time is The Penray Companies, Inc., 1801 Estes Ave., Elk Grove, IL 60007. If you are aware of alternative suppliers, please provide this information to ASTM Headquarters. Your comments will receive careful consideration at a meeting of the responsible technical committee,¹ which you may attend.

8.4.3 Engine Coolant System:

8.4.3.1 Configure the engine cooling system according to the schematic diagram shown in Fig. A3.7, and the photographs in Fig. A3.8 and Fig. A3.9. Install a thermocouple into a modified thermostat housing and install the thermostat housing. *Do not install the thermostat.* Inspect the water pump drive V-belt for defects before installation. Install and tension the water pump drive V-belt.

8.4.3.2 A radiator cap is used to limit system pressure, although the coolant system pressure is not measured or controlled. The heat exchanger and control valve size are not specified, but the total coolant system capacity should be minimized.

8.4.3.3 The engine coolant flow rate and outlet temperature are controlled in accordance with the specifications listed in Table 2. Information concerning the coolant flow rate measurement device is detailed in 9.3.2. Cyclic ramping specifications are detailed in Table 4. The coolant flow rate is measured with a venturi flowmeter and varied with a control valve or a manual valve.

8.4.3.4 Maintain engine coolant system pressure at 10 ± 1 psig. Measure coolant system pressure at the top of the fluid level in the coolant reservoir.

8.4.4 RAC Coolant System:

8.4.4.1 Periodically inspect and clean the complete RAC control system. If a high level of RAC coolant jacket deposit is found, flush the complete cooling system. A specific flushing technique is not specified. However, the technique should employ a commercial descaling cleaner.

8.4.4.2 Schematic diagrams of typical RAC coolant control systems are shown in Fig. 5 and Fig. 6. Heat for the control system can be derived from an external source, such as the marine manifold, an electric immersion heater, hot water, or steam.

8.4.4.3 Control the RAC coolant flow rate and inlet temperature in accordance with the specifications listed in Table 2. The coolant pressure is not specified, but design the system to minimize the pressure on the RAC and prevent distortion of the jacket. (**Warning**—Maintain the system pressure below 10 psig (69 kPa) to prevent distortion of the RAC jacket.)

8.4.4.4 Cyclic ramping specifications are detailed in Table 4.

8.4.5 Exhaust Manifold Coolant System:

8.4.5.1 Do not circulate coolant from the engine jacket through the exhaust marine manifold.

8.4.5.2 Exhaust system components downstream of the exhaust gas sampling and exhaust back pressure measurement fitting are not specified. Water-cooled exhaust plumbing downstream of the exhaust probes is a typical laboratory practice. The design should minimize buildup of corrosive materials in the exhaust system. The exhaust back pressure control equipment shall provide stable control within the limits specified. (**Warning**—Good engineering practices should be utilized to ensure safe operation of this system. The coolant outlet temperature of the marine manifold should be maintained below the boiling point of the coolant. High temperature, low water flow, and low water pressure alarms are recommended to

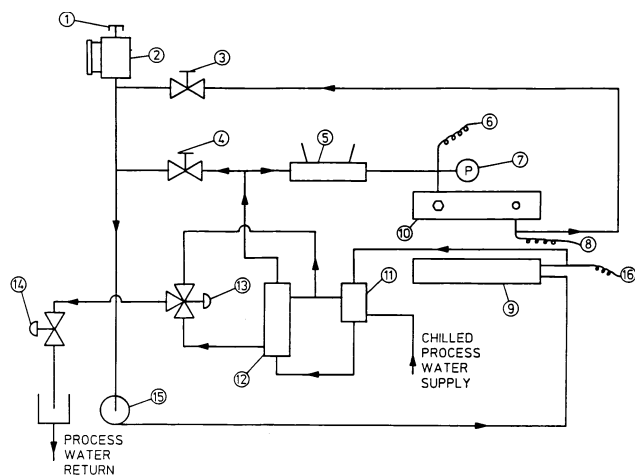

- ① VENTED RESERVOIR CAP.
- ② COOLANT RESERVOIR.
- ③ PRESSURE CONTROL VALVE (OPTIONAL)
- ④ FLOW CONTROL VALVE
- ⑤ FLOW MEASUREMENT DEVICE.
- ⑥ INLET TEMPERATURE SENSOR.
- ⑦ SYSTEM PRESSURE MEASUREMENT
- ⑧ OUTLET TEMPERATURE SENSOR
- ⑨ EXHAUST MARINE MANIFOLD.
- ⑩ ROCKER ARM COVER.
- ⑪ STAGE I, II, & III HEAT EXCHANGER.
- ⑫ STAGE I & III HEAT EXCHANGER.
- ⑬ STAGE CHANGE 3-WAY VALVE.
- ⑭ PROCESS WATER CONTROL VALVE.
- ⑮ ELECTRIC COOLANT PUMP
- ⑯ EXHAUST MARINE MANIFOLD OUTLET TEMPERATURE SENSOR (HIGH TEMPERATURE SAFETY CUT OUT)

FIG. 5 Typical Waste Heat Rocker Arm Cover Heating and Cooling System

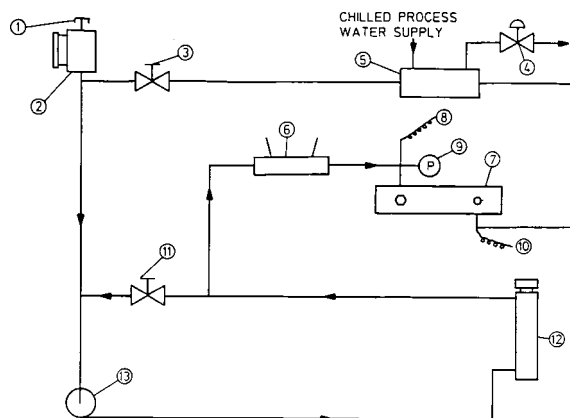

- ① VENTED RESERVOIR CAP.
- ② COOLANT RESERVOIR
- ③ PRESSURE CONTROL VALVE (OPTIONAL)
- ④ CHILLED PROCESS WATER CONTROL VALVE
- ⑤ STAGE I & III HEAT EXCHANGER
- ⑥ FLOW MEASUREMENT DEVICE.
- ⑦ ROCKER ARM COVER.
- ⑧ INLET TEMPERATURE SENSOR
- ⑨ SYSTEM PRESSURE MEASUREMENT.
- ⑩ OUTLET TEMPERATURE SENSOR
- ⑪ FLOW CONTROL VALVE
- ⑫ EXTERNAL HEAT SOURCE.
- ⑬ ELECTRIC COOLANT PUMP

FIG. 6 Typical Non-Waste Heat Rocker Arm Cover Heating and Cooling System

prevent damage due to lack of cooling during engine operation.)

9. Measurement Instrumentation

9.1 Temperatures:

9.1.1 Equipment:

9.1.1.1 Temperature measurement equipment and locations for the seven required temperatures are specified. Alternative temperature measurement equipment shall be approved by the TMC. The accuracy and resolution of the temperature measurement sensors and the complete temperature measurement system shall follow the guidelines detailed in ASTM Research Report RR: D02-1218.²⁸

9.1.1.2 If thermocouples are used, all thermocouples except the intake-air thermocouple shall be premium, sheathed, grounded types with premium wire. The intake-air thermocouple may be an open-tip type. Thermocouples of 0.125, 0.1875, or 0.25-in. (3.2, 4.8, or 6.4-mm) diameter may be used. However, 0.125-in. (3.2-mm) thermocouples are recommended at locations that require short immersion depths to prevent undesirable temperature gradients. Thermocouples, wires, and extension wires should be matched to perform in accordance with the special limits of error as defined in ANSI MC96.1. Either Type J (iron-constantan) or Type T (copper-constantan) thermocouples are acceptable (see ANSI MC96.1).

9.1.1.3 Resistance thermometer detectors (RTDs) are acceptable alternatives to thermocouples. However, if the TMC is not familiar with the particular RTDs used, the laboratory will be required to demonstrate equivalent system accuracy to the specifications noted in 9.1.1.2 (see ANSI MC96.1).

9.1.2 *Engine Coolant Inlet*—Install the tip at the center of the flow stream in the perpendicular intersection of the tee fitting located 12 to 16-in. (300 to 410-mm) upstream from the water pump inlet (see Fig. A3.7). The recommended thermocouple diameter is 0.125 in. (3.2 mm).

9.1.3 *Engine Coolant Outlet*—Install the tip of the thermocouple at the center of the flow stream in the modified thermostat housing. The thermocouple tip shall be within 1 in. (25.4 mm) of the cylinder head. The inside diameter or inner orifice of the thermostat housing shall be no smaller than the Ford factory orifice and no larger than the cylinder head coolant inlet passage.

9.1.4 *Engine Oil Inlet*—Install the tip at the base of mounting face of the adapter block (see Fig. A3.10 and Fig. A3.13). The recommended thermocouple diameter is 0.125 in. (3.2 mm).

9.1.5 *Engine Oil Outlet*—Install the tip at the center of the cross fitting attached to the bottom of the heat exchanger (see Fig. A3.10). The recommended thermocouple diameter is 0.125 in. (3.2 mm).

9.1.6 *Intake Air*—Install the tip midstream in the intake-air horn adapter (see Fig. A3.4). A 0.25-in. (6.4-mm) thermocouple is adequate if an open-tip thermocouple is used.

²⁸ ASTM Research Report RR: D02-1218, "Data Acquisition Guidelines—Instrumentation Accuracy and Calibration;" available from ASTM Headquarters, 100 Barr Harbor Drive, West Conshohocken, PA 19428.

9.1.7 *RAC Coolant Inlet*—Install the tip at the center of the cross fitting attached to the RAC inlet fitting (see Fig. A3.14). The recommended thermocouple diameter is 0.125 in. (3.2 mm).

9.1.8 *Marine Manifold Coolant*—Install the tip at the perpendicular intersection of the tee fitting located on the outlet (upper) port of the marine manifold (see Fig. A3.8). Since the marine manifold coolant temperature is not a controlled parameter, a 0.25-in. (6.4-mm) thermocouple is adequate.

9.1.9 *Calibration*—Calibrate the engine oil in, engine coolant out, RAC and intake-air temperature measurement sensors every ninety days. Calibrate all other temperature sensors prior to each reference oil test. The temperature measurement system shall indicate within $\pm 1^\circ\text{F}$ (0.6°C) of the laboratory calibration standard, which shall be traceable to national standards.

9.2 Pressures:

9.2.1 *Equipment*—Pressure measurement for each of the eight required parameters is detailed in the following sections. Specific measurement equipment is not specified. This allows reasonable opportunity for adaption of existing test stand instrumentation. However, the accuracy and resolution of the pressure measurement sensors and the complete pressure measurement system shall follow the guidelines detailed in ASTM Research Report RR: D02-1218.²⁸

NOTE 8—Tubing between the pressure tap locations and the final pressure sensors should incorporate condensate traps, as indicated by good engineering practice. This is particularly important in application where low air pressures are transmitted by means of lines that pass through low-lying trenches between the test stand and the instrument console.

9.2.2 *Intake Manifold Vacuum*—Measure the intake manifold vacuum at the top side of the upper intake manifold as detailed in Fig. A3.21.

9.2.3 *Oil Pressure*—Make oil pressure measurements at the oil filter adapter housing inlet, oil filter housing outlet, and the rear corner of the cylinder head, as shown in Fig. A3.13. A multi-position selector valve can be utilized to connect the three oil pressure taps to a single pressure sensor. Individually dedicated pressure sensors may also be utilized.

9.2.4 *RAC Coolant Pressure*—Measure the RAC coolant pressure at the coolant inlet cross fitting, as detailed in Fig. A3.14.

9.2.5 *Fuel Pressure*—Measure the fuel pressure at the injector rail inlet as shown in Fig. 4. When utilizing a pressure gage mounted directly to the injector rail, the gage should be a damped, liquid-filled type.

9.2.6 *Intake-Air Pressure*—Measure the intake-air pressure at the air horn with the probe, as shown in Fig. 1 and detailed in Fig. A3.3, Fig. A3.4, and Fig. A3.5. If a manometer is used, install a liquid trap to prevent manometer fluid from entering the intake-air horn.

9.2.7 *Crankcase Pressure*—Measure the crankcase pressure at the dipstick tube. The sensor shall be capable of measuring positive and negative pressure. If a manometer is utilized, install a liquid trap to prevent manometer fluid from entering the crankcase.

9.2.8 *Exhaust Back Pressure*—Measure exhaust back pressure with the exhaust sampling probe downstream of the

marine manifold (see Fig. 3 and Fig. A3.5). Install the exhaust gas sample and exhaust back pressure probe assembly against the marine manifold. A sensor capable of absolute measurement or a gage measurement corrected with a barometric pressure reading is acceptable. Install a condensate trap between the probe and sensor to accumulate water present in the exhaust gas.

9.2.9 *Engine Coolant Pressure*—Measure the coolant pressure above the fluid level in the engine reservoir, as shown in Fig. A3.7. Maintain engine coolant system pressure at 10 ± 1 psig (69 ± 6.9 kPa).

9.2.10 *Calibration*—Calibrate all pressure sensors, including the RAC and engine coolant flow differential pressure and coolant pressure measurement sensors prior to each reference oil test. The calibration standard shall be traceable to national standards.

9.3 Flow Rates:

9.3.1 *Equipment*—Flow rate measurement procedures for each of the four required parameters are detailed in the following subsections. With the exception of the engine coolant and blowby flow rates, measurement equipment is not specified for a given parameter. This allows reasonable opportunity for adaption of existing test stand instrumentation. The accuracy and resolution of the flow rate measurement system shall follow the guidelines detailed in ASTM Research Report RR: D02-1218.²⁸

9.3.2 *Engine Coolant*—Determine the engine coolant flow rate by measuring the differential pressure drop across the specified venturi flowmeter (see Fig. A3.7). The pressure drop is approximately 18 in. (4.5 kPa) H_2O in the controlled flow range. Take precautions to prevent air pockets from forming in the lines to the pressure sensor. Transparent lines are beneficial in this application.

9.3.3 *RAC Coolant*—Measure the total volumetric coolant flow rate through the RAC.

9.3.3.1 *Calibration*—Calibrate the flowmeters used in the measurement of both the engine coolant flow rate and RAC coolant flow rate before every reference oil test. Calibrate the flowmeters as installed in the system at the test stand. Alternatively, the flowmeters may be detached from the test stand and calibrated, providing the adjacent upstream and downstream plumbing is left intact during the calibration process. Calibrate the flowmeters with a turbine flowmeter or by a volume/time method, at Stage 1 operating conditions.

9.3.4 Blowby:

9.3.4.1 Measure the blowby flow rate using the apparatus shown in Fig. 7. The measurement system routes the blowby through an external, sharp-edged orifice and into the engine intake manifold by means of an auxiliary (*dummy*) PCV valve. Mount the orifice plate with the flow in a horizontal position. Maintain crankcase pressure at 0.0 ± 0.1 in. (0.0 ± 25 Pa) during operation of the system to minimize the potential for crankcase leakage. *Mount the dummy PCV valve in a vertical position.*

9.3.4.2 Determine the blowby flow rate by measuring the differential pressure drop across the sharp-edged orifice; an inclined manometer or differential pressure sensor is required

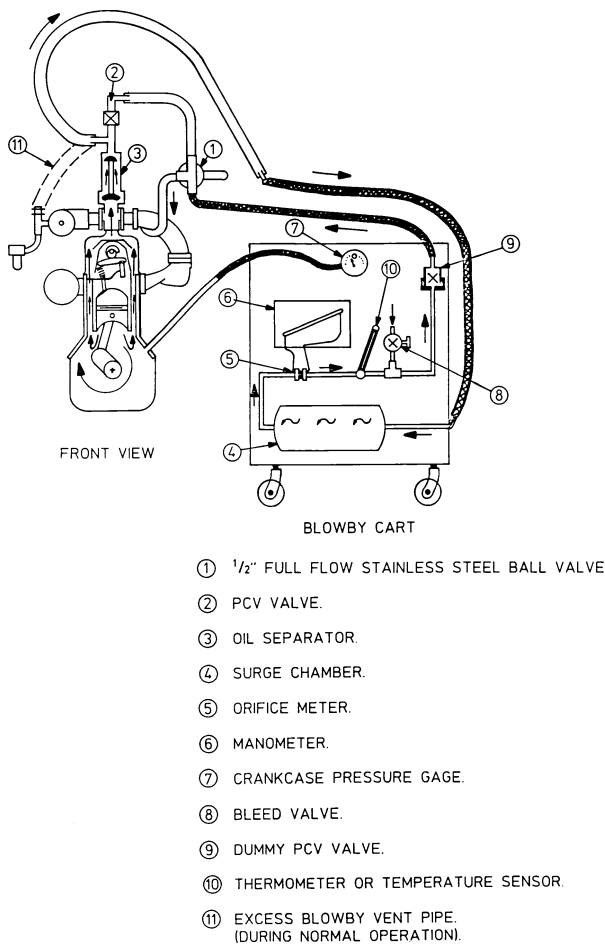

FIG. 7 Blowby Measurement Apparatus

for measurement of the differential pressure drop. The crankcase pressure sensor shall have a range from 0 to 4 in. (0 to 1 kPa) H₂O and be adequately damped to indicate a zero gage pressure.

9.3.4.3 The sharp-edged orifice assembly is specifically designed for blowby flow rate measurement and shall be fabricated in strict compliance with the specifications, that are available from the TMC. The assembly contains five orifices. The 0.375-in. (9.53-mm) orifice is generally satisfactory for the range of blowby flow rate encountered. The complete orifice assembly can also be purchased from the supplier listed in Appendix X2. Additional details concerning fabrication of the flow rate measurement orifice assembly and measurement of blowby flow rate can be found in Footnote 14.

9.3.4.4 *Maintenance*—Clean the blowby measurement apparatus at least once every seven days. Replace the O-ring with each cleaning. Exercise particular care when cleaning the orifice meter assembly. Clean the three-way valve by soaking the valve in agitated organic solvent (see 7.7.3) until clean, followed by hot (>140°F (>60°C)) water rinse and spray rinse with aliphatic naphtha. Use compressed air to force air-drying. Inspect the port passages and remove any carbonaceous deposits by scraping. If the valve is disassembled for cleaning, make sure the core is properly seated upon reassembly. **(Warning)**—Internal leakage within the three-way valve may cause some of the blowby gas to pass directly to the intake

manifold from the test PCV valve and result in erroneous blowby flow rate measurements (see Fig. 7)).

9.3.4.5 *Calibration*—Calibrate the blowby orifice meters used for laboratory measurements every six months. Calibrate laboratory blowby measurements standards, used for the calibration of other meters, yearly. The calibration standard shall be traceable to national standards. Calibrate the temperature measuring devices in the blowby system every six months.

9.4 *Fuel Consumption*—Determine the fuel consumption rate by measuring the amount of make-up fuel flowing from the external fuel tank. The measurement point is upstream of the return flow from the fuel rail (see Fig. 4).

9.4.1 *Calibration*—Calibrate mass flow systems or gravimetric systems before every reference oil test. Volumetric systems shall be temperature-compensated and calibrated against a mass flow device. Values obtained with the test stand measuring device shall be within 1 % of the calibration standard values.

9.5 *Speed and Load:*

9.5.1 *Required Capabilities*—The dynamometer speed and load control systems shall be capable of maintaining the limits specified in Table 2 and meet the ramping requirements specified in Table 4 and Table 5. These limits require control within ±0.4 % for operation during Stages 1 and 2. Because the dynamometer and driveline frictional losses may approach the Stage 3 load, manage the control input and system response during Stage 3 carefully to maintain engine operation within the specified tolerances. These tolerances are necessary to maintain a stable air-fuel ratio during Stage 3. Hydraulic dynamometers have a high residual load and may not be suitable for operation during Stage 3.

9.5.2 *Suitable Systems*—Both partial and full closed-loop systems have been successfully utilized. A typical partial closed-loop system maintains speed by varying dynamometer excitation and maintains load by a fixed throttle. A typical

TABLE 5 Sequence VE Break-in Test Condition Ramping Requirements

<i>Break in Dipstick Calibration Engine Start-Up to Step B</i>	
Engine speed	Must reach 2490 rpm within 0.5 to 1.5 min
Engine power	Must reach 33.5 ± 0.5 bhp within 0.5 to 2.0 min
Oil inlet temperature	127 to 143°F at 7 min Must reach 208°F within 25 min
Coolant outlet temperature	143 to 167°F at 8.5 min Must reach 183°F in 13 ± 2 min
Rocker arm cover inlet temperature	>95°F at 2 min 125 to 145°F at 6.5 min Must reach 183°F in 13 ± 2 min
<i>Break In Step B to C</i>	
Engine speed	Must reach 775 rpm within 0.5 to 2.0 min
Engine power	Must reach 1 ± 0.5 hp within 0.5 to 2.0 min
Oil inlet temperature	149 to 177°F at 6.5 min Must reach 117°F in 13 ± 2 min
Coolant outlet temperature	131 to 169°F at 3.5 min Must reach 117°F in 7 ± 2 min
Rocker arm cover inlet temperature	125 to 145°F at 6.5 min >95°F at 10 min Must reach 87°F in 13 ± 2 min

TABLE 5 (M) Sequence VE Break-in Test Condition Ramping Requirements (continued)

<i>Break in Dipstick Calibration Engine Start-Up to Step B</i>	
Engine speed	Must reach 2490 r/min within 0.5 to 1.5 min
Engine power	Must reach 25.0 ± 0.37 kW within 0.5 to 2.0 min
Oil inlet temperature	52.8 to 61.7°C at 7 min Must reach 97.8°C within 25 min
Coolant outlet temperature	61.7 to 75.0°C at 8.5 min Must reach 83.9°C in 13 ± 2 min
Rocker arm cover inlet temperature	>35.0°C at 2 min 51.7 to 62.8°C at 6.5 min Must reach to 83.9°C in 13 ± 2 min
<i>Break In Step B to C</i>	
Engine speed	Must reach 775 r/min within 0.5 to 2.0 min
Engine power	Must reach 0.75 ± 0.37 within 0.5 to 2.0 min
Oil inlet temperature	65.0 to 80.6°C at 6.5 min Must reach 47.2°C in 13 ± 2 min
Coolant outlet temperature	55.0 to 76.1°C at 3.5 min Must reach 47.2°C in 7 ± 2 min
Rocker arm cover inlet temperature	51.7 to 62.8°C at 6.5 min >35.0°C at 10 min Must reach 30.6°C in 13 ± 2 min

closed-loop system maintains engine speed by varying dynamometer load and maintains engine load by varying the engine throttle position.

9.5.3 Calibration—Calibrate the load measurement and readout system with deadweights at least once per test. Calibration of the zero scale readout is recommended once per day when the test stand is in use. Calibrate the speed measurement system prior to each reference oil test.

9.6 Exhaust Gas:

9.6.1 Equipment:

9.6.1.1 Precision instruments for measurement of O₂, CO, and NO_x are required. Equipment suitable for automobile emission measurements is recommended. Precision nondispersive infrared instrumentation for CO and polarographic instrumentation for O₂ are suggested (see SAE J254). Response time is an important consideration in the performance of this instrumentation. A CO meter capable of measuring CO from 0 to 20 % is also required, for determining CO values during Stage 2 to 3 and 3 to 1 transitions. An extended range air-fuel ratio (UGEO) sensor can also be used to determine CO values during transitions. To decrease the response time of the meter, it is recommended that the CO meter or UGEO sensor be mounted as close to the stand as possible or in a portable installation.

9.6.1.2 A typical exhaust gas analysis system is shown in Fig. 3. The required instrument calibration gases are listed in Note of Fig. A3.6, and system design details are specified in Fig. A3.5 and Fig. A3.6. (**Warning**—Safety precautions are necessary concerning venting carbon monoxide, nitrous oxide, and ozone gases from the analyzer instruments.) (**Warning**—Long sample lines and unnecessary fitting connections or valves between the sample probe and the analyzer increase the potential for measurement error.)

9.6.2 Calibration—General—Calibrate the exhaust gas analysis equipment before each set of measurements taken during the test. The calibration technique should compensate

for the flow rate sensitivity of the exhaust gas analysis meters.

9.6.3 CO Meter Calibration for Transitions—For ramping transitions, calibrate the CO meter from 0 to 15 % CO, as well as response time to ensure accurate readings during stage transitions. A zero and span calibration is required every day that the CO meter is used. No more than seven stage transition recordings or a maximum of one week is to transpire between a full stabilized and response calibration.

9.6.3.1 Conduct *stabilized* calibrations with the following nominal calibration gases: 0, 0.5, 6.5, and 15 % CO. The same trace recorder used for the transition traces (see Fig. A7.18) is used for the calibration. Zero and span the CO meter to the 15 % CO bottle. The calibration of the indicated and actual CO measurements of 0.5, 6.5, and 15 % CO shall be within 0.5 % and the zero and span within 0.2 % CO.

9.6.3.2 Conduct *response* calibrations with the 0.5 and 15 % nominal CO calibration gases. Use a solenoid valve to switch between the calibration sample bottles (see Fig. A7.19). Connect the solenoid valve directly to the longest sample line in the CO measurement system. Make the connection where the sample line would normally go onto the exhaust pipe. Use the same sample flow rate for the calibration as that used for transition trace recordings. The same trace recorder used for the transition trace recordings (see Fig. A7.18) is used for calibration. Show the solenoid switching voltage on one of the trace recorder channels. The solenoid valve switches the sample gas from the 0.5 to 15.0 to 0.5 % CO bottles at 40-s intervals. For satisfactory calibration, the indicated CO % shall duplicate the actual 15 % CO bottle value ± 0.3 % CO (see Fig. A7.18).

9.6.3.3 If an UEGO sensor is used to determine CO values, correlate the sensor voltage output every six months or after 1000 h of use, whichever occurs first, to CO levels at the following conditions:

Speed	1500 ± 10 r/min (157.1 ± 1.05 rad/s)
Power	6 ± 0.5 hp (4.5 ± 0.4 kW)
Engine coolant outlet temperature	150 ± 2°F (65.6 ± 1°C)
CO levels at	4, 6.5, 10, and 15 %

Install the UEGO sensor to avoid obstruction of the exhaust backpressure and air-fuel ratio probes. Where continuous air purge is maintained on the air-fuel ratio probe, install the sensor upstream of the exhaust backpressure and air fuel ratio probes.

9.7 Humidity—Measure humidity with the laboratory's primary humidity stream. Correct each reading for non-standard barometric conditions, using the following equation:

$$\text{Humidity (corrected)} = 4354 \times (P_{\text{sat}} / (P_{\text{bar}} - P_{\text{sat}})) \quad (3)$$

where:

P_{sat} = saturation pressure, in. Hg, and

P_{bar} = barometric pressure, in. Hg.

Metric Units:

$$\text{Humidity (corrected)} = 621.98 \times (P_{\text{sat}} / (P_{\text{bar}} - P_{\text{sat}})) \quad (4)$$

where:

P_{sat} = saturation pressure, mm Hg, and

P_{bar} = barometric pressure, mm Hg.

9.7.1 Calibration—Calibrate the primary laboratory measurement system at each stand on a semiannual basis using a

hygrometer with a minimum dew point accuracy of $\pm 1^{\circ}\text{F}$ at 60°F ($\pm 0.55^{\circ}\text{C}$ at 16°C). Locate the sample tap on the air supply line to the engine, between the main duct and 2 ft upstream of the intake air horn. The calibration consists of a series of paired humidity measurements comparing the laboratory system with the calibration hygrometer. The comparison period lasts from 20 min to 2 h with measurements taken at 1 to 6 min intervals, for a total of 20 paired measurements. The measurement interval shall be appropriate for the time constant of the humidity measuring instruments.

9.7.1.1 Verify that the flow rate is within the equipment manufacturer's specification, and that the sample lines are non-hygroscopic. Correct dew point hygrometer measurements to standard conditions (29.92 in. Hg [101.12 kPa]) using the appropriate equation (see 9.7). Compute the difference between each pair of readings and calculate the mean and standard deviation of the 20 paired readings, using equations Eq A13.1 and Eq A13.2 in Annex A13. The absolute value of the mean difference shall not exceed 10 grains/lb (1.43 g/kg) and the standard deviation shall not be greater than 5 grains/lb (0.714 g/kg). If these conditions are not met, investigate the cause, make repairs, and recalibrate. Maintain calibration records for two years.

10. Miscellaneous Laboratory Equipment

10.1 *Timing Light*—Use an inductive pickup timing light to measure ignition timing.

10.2 *Volumetric Graduates*—Measure the test oil quantity, fresh and used, by volume. A 16-oz (500-mL) (fluid) graduate is recommended for the small samples (2 to 10 oz [60 to 300 mL]); this graduate shall have a resolution of 0.25 oz (7 mL) (fluid). A large graduate, capable of transferring 124 oz (4 L) (fluid), is required, and it shall have a resolution of 1.0 oz (30 mL) (fluid). All graduates shall have an accuracy of 2 % of full scale.

11. Test Standard Calibration

11.1 *Verification:*

11.1.1 Verify the calibration of test stands with reference oils supplied by the TMC. Stand calibration tests are normally conducted upon expiration of the 180-day calibration time period. However, calibration time periods may be adjusted by the TMC. Any deviation from the standard calibration time frequency shall be approved by the TMC and reported on a supplemental operational data sheet of the final test report. Any non-reference test started within 168 days of the completion date of the previous calibration test is considered within the calibration time period.

11.1.2 A 3.0-gal (11.4-L) sample of reference oil is provided by the TMC for each stand calibration test.

11.2 *Unacceptable Calibration Results:*

11.2.1 It is recognized that a certain percentage of calibration tests will fall outside the acceptance limits because of the application of statistics in the development of the acceptance limits. Failure of a reference oil test to meet Shewhart or exponentially weighted moving average (EWMA) precision control chart limits can be indicative of a false alarm or a stand, laboratory, or industry problem. When this occurs, the laboratory in conjunction, with the TMC, shall attempt to determine

the problem source. The TMC may solicit input from industry expertise (other testing laboratories, the test sponsor, ASTM Technical Guidance Committee, Sequence VE Surveillance Panel, Sequence VE Operations and Hardware Subpanel, and so forth) to help determine the cause and extent of a problem. Industry problems shall be adjudicated by the Sequence VE Surveillance Panel.

11.2.2 If the TMC determines the problem is a false alarm, and is stand related, there is no impact on non-reference tests running in other stands within the laboratory. If the TMC determines the problem is laboratory related, non-reference tests run during the problem period shall be considered invalid, unless there is specific evidence to the contrary for each individual test.

11.2.3 The TMC will reschedule a calibration test once it is satisfied that no particular problem exists or the problem has been resolved. The laboratory shall provide adequate documentation to support the conclusions reached during this process. This documentation shall be attached to the acceptable calibration test report. It shall provide sufficient information to show how the problem related to other tests operated during the same period of time.

11.3 *Test Stand Modifications*—Report modification of test stand control systems or completion of any nonstandard test on a calibrated stand to the TMC immediately. A nonstandard test includes any test completed under a modified procedure requiring hardware or controller tuning modifications to the test stand. The TMC will determine whether another calibration test is necessary after the modifications have been completed.

11.4 *Reference Oil Accountability:*

11.4.1 Laboratories conducting calibration tests are required to provide a full accounting of the identification and quantities of all reference oils used.

11.4.2 With the exception of new oil analysis required in 13.7.1, no physical or chemical analysis of new reference oils shall be performed without the permission of the TMC. Retain engine parts from reference oil tests for six months.

11.5 *Test Numbering System:*

11.5.1 *Acceptable Tests*—The test number shall follow the format *AAA-BB-CCC*. *AAA* represents the stand number. *BB* represents the number of tests since the last reference. *CCC* represents the total number of tests on the stand. As an example, *6-10-175* represents the 175th test on Stand 6 and the 10th test since the last reference. Consecutively number all tests on a given stand.

11.5.2 *Unacceptable or Aborted Tests*—If a calibration test is aborted or the results are outside the acceptance limits, the *CCC* portion of the test number for subsequent calibration test(s) shall include a letter suffix. The suffix shall begin with the letter *A* and continue alphabetically until a calibration test is completed within the acceptance limits. For example, if three consecutive unacceptable calibration tests are completed on the same test stand, and the test number of the first test is *6-0-175*, the next two test numbers would be *6-0-175A* and *6-0-175B*. If the results of the next calibration test are acceptable, the test number *6-0-175C* would permanently identify the test and appear on future correspondence. The completion of any

amount of operational time on tests other than calibration tests will cause the test number to be increased by one. No letter suffix will be added to the test number of tests other than calibration tests.

12. Procedure

12.1 Pre-Test Procedure:

12.1.1 Engine Cooling System Flushing:

12.1.1.1 Use the following detailed procedure to flush the engine cooling system (use a flushing cart similar to the design shown in Fig. 2). The circulating pump shall be capable of flowing cleanser neutralizer and water at a rate of 25 ± 5 gal/min [95 ± 19 L/min]. Calibrate the temperature, flow rate, and volume measuring equipment for the engine coolant flush cart at least every six months at the operating temperature of 150°F [65.6°C]).

12.1.1.2 Isolate the hoses leading from the venturi meter to the differential pressure sensor by closing the valves or removing the hoses at the venturi.

12.1.1.3 Remove the engine oil drain plug. This allows any accumulated build-up oil to drain. It also allows a way to determine the presence of any internal leaks while completing the flushing procedure.

12.1.1.4 Close the valve above the heat exchanger and isolate the coolant reservoir. This is necessary to prevent a loss of fluid during the flushing procedure and to avoid accumulation of flushing material in the coolant reservoir.

12.1.1.5 Isolate the water pump bypass by disconnecting the return hose from the intake manifold and routing it to the flush cart tank (see Fig. A3.41). Plug the water pump bypass port. (**Warning**—The flow rate through the intake manifold return hose should be choked down to prevent excessive flow rates through the intake manifold during flushing. This is a safety precaution and will not prevent adequate flushing of the intake manifold.)

12.1.1.6 Connect the flush cart outlet hose to the water pump inlet. Connect the flush cart inlet hose to the engine coolant outlet from the heat exchanger.

12.1.1.7 Fill the engine and flush cart with tap water (demineralized or distilled water if the tap water has a high mineral content). Circulate the water through the engine and flush cart to heat the water. Continue circulation and heating until the water temperature reaches $150 \pm 10^\circ\text{F}$ ($66 \pm 6^\circ\text{C}$).

12.1.1.8 Isolate the flush cart from the engine cooling system by opening the flush cart recirculation valve and closing the inlet and outlet valves.

12.1.1.9 Add the oxalic acid (see 7.7.6) at the rate of 3 oz/gal (23 g/L) of water in the flush cart system; add Petro Dispersant 425 (see 7.7.6) at the rate of 0.15 oz/gal (1 g/L). Add the cleanser directly to the flushing water.

12.1.1.10 Allow the oxalic acid to mix for 2 min in the flush cart. Open the inlet and outlet valves to the engine, and close the recirculation valve. Circulate the oxalic acid through the cooling system at a flow rate of 25 ± 5 gal/min (1.6 ± 0.3 L/s) for 45 min while maintaining a temperature of $150 \pm 10^\circ\text{F}$ ($66 \pm 6^\circ\text{C}$).

12.1.1.11 Drain the cleanser from the engine cooling system and the flush cart. Flush the system with tap water (25 ± 5 gal/min, $<100^\circ\text{F}$ [95 ± 19 L/min, $<43.7^\circ\text{C}$]) until the cooling

system and flush cart drains run clear.

12.1.1.12 Close the cooling system and flush cart drains. Fill the engine and flush cart with tap water and circulate the water throughout the engine until the water temperature reaches $150 \pm 10^\circ\text{F}$ ($66 \pm 6^\circ\text{C}$).

12.1.1.13 Isolate the flushing cart from the engine cooling system by opening the flush cart recirculation valve and closing the inlet and outlet valves.

12.1.1.14 Add the sodium carbonate at the rate of 0.05 oz/gal (3.8 g/L) of water in the flush cart system. Add the neutralizer directly to the flushing water.

12.1.1.15 Allow the neutralizer to mix for 2 min in the flush cart. Open the inlet and outlet valves to the engine and close the recirculation valve. Circulate the neutralizer through the cooling system at 25 ± 5 gal/min (1.6 ± 0.3 L/s) for 45 min while maintaining a temperature of $150 \pm 10^\circ\text{F}$ ($66 \pm 6^\circ\text{C}$).

12.1.1.16 Drain the neutralizer from the engine cooling system and the flush cart. Flush the engine cooling system and the flush cart with tap water at 25 ± 5 gal/min (95 ± 19 L/min) until the pH of the incoming and the outgoing water is the same. The temperature of the tap water shall be below 100°F (43.7°C).

12.1.1.17 Drain the cooling system, remove one or more freeze plugs, and inspect the coolant jacket. The cylinder walls should be clean and free of deposits when wiped. Install new freeze plugs quickly to help prevent the coolant jackets from rusting. If deposits are still present in the coolant jacket, repeat 12.1.1.6-12.1.1.17.

12.1.1.18 Disconnect the flush cart and reconnect the intake manifold coolant return line to the water pump bypass port. Reconnect the heat exchanger outlet to the water pump inlet. Charge the engine and RAC with premixed coolant (described in 8.4.1) immediately to prevent rusting of the coolant jacket.

12.1.2 *Initial Test Oil Charge*—Reinstall the oil pan drain plug and charge 124 ± 1 oz (3.67 ± 0.03 L) (fluid) of the candidate test oil to the crankcase.

12.1.3 *Engine Pre-Lubrication*—Rotate the oil pump clockwise until oil pressure registers in the cylinder head gallery. Turn the crankshaft a minimum of two full revolutions during the pre-lubrication procedure to ensure that the camshaft is wetted with test oil during the initial engine start-up (see 8.3.5).

12.1.4 Engine Break-In Procedure:

12.1.4.1 The laboratory ambient atmosphere shall be reasonably free of contaminants. The temperature and humidity level of the operating area are not specified. Divert air from fans or ventilation systems away from the test engine.

12.1.4.2 Prior to Step A of the break-in procedure, start the engine and adjust timing to 28° BTDC at 750 r/min.

12.1.4.3 During Step A (see Table 6 and Table 7), set the ignition-timing at 28° BTDC and allow the oil and coolant temperatures to reach 115°F (46°C). Adjust the fuel injector pulse width to provide 6.5 % CO maximum in the exhaust. Bleed the air from the engine and RAC coolant systems.

12.1.4.4 During Steps B and C (see Table 6 and Table 7), all parameters shall be controlled and recorded as normal test Stage 2 and Stage 3 conditions. Record all *normal* parameters in Steps B and C after operation for 35 min. In addition, record fuel pressure and RAC coolant pressure during Steps B and C.

TABLE 6 Sequence VE Break-in Schedule

Conditions	Step		
	A (Timing Run)	B	C
Time per step (minutes)	10	40	40
Cumulative time (minutes)	10	50	90
Engine speed (rpm)	1500 ± 25	2500 ± 10	750 ± 25
Engine load (bhp)	2 ± 0.5	33.5 ± 0.5	1 ± 0.5
Water out (°F)	115 ^A	185 ± 2	115 ± 2
Oil into engine (°F)	115 ^A	210 ± 2	115 ± 2
RAC inlet (°F)	85 ^A	185 ± 2	85 ± 2
RAC flow (gpm)	2 ± 0.2	...	2 ± 0.2
RAC pressure (psig)	...	10 max	10 max
Fuel pressure (psig) ^B	...	27 to 40	27 to 40
Exhaust gas CO (%)	6.5 max	0.4 max	6.5 ± 0.5
Exhaust gas O ₂ (%)	...	1.1 to 0.3, + 0.1	0.7 max

^A Target value.

^B Fuel pressure should be constant at steady state but within the given range.

TABLE 7 (M)Sequence VE Break-in Schedule

Conditions	Step		
	A (Timing Run)	B	C
Time per step (minutes)	10	40	40
Cumulative time (minutes)	10	50	90
Engine speed (rpm)	1500 ± 25	2500 ± 10	750 ± 25
Engine load kW	1.50 ± 0.37	25.00 ± 0.37	0.75 ± 0.37
Water out °C	46.1 ^A	85.0 ± 1.1	46.1 ± 1.1
Oil into engine °C	46.1 ^A	98.9 ± 1.1	46.1 ± 1.1
RAC inlet °C	29.4 ^A	85.0 ± 1.1	29.4 ± 1.1
RAC flow L/min	7.6 ± 0.7	...	7.6 ± 0.7
RAC pressure kPa	...	68.9 max	68.9 max
Fuel pressure kPa ^B	...	186 to 276	186 to 276
Exhaust gas CO (%)	6.5 max	0.4 max	6.5 ± 0.5
Exhaust gas O ₂ (%)	...	1.1 to 0.3, + 0.1	0.7 max

^A Target value.

^B Fuel pressure should be constant at steady state but within the given range.

NOTE 9—The fuel pressure and the RAC coolant pressure are not recorded after the break-in.

12.1.4.5 At the earliest opportunity in each step, adjust the fuel injector pulse width to provide the specified values for CO and O₂ in the exhaust. (**Warning**—Prolonged operation at a rich air-fuel ratio can cause excessive fuel dilution and alter test severity.)

NOTE 10—The engine will normally require approximately 15 min to reach steady-state conditions after a stage change.

12.1.5 *Dipstick Calibration*—After the completion of Step A (see Table 6), shut the engine down (see 12.2.2). Disconnect the intake-air supply immediately after shutdown to cause the inlet air pressure to fall to atmospheric. After 20 min, calibrate the dipstick *full* mark at the existing sump level and set the lock nuts on the adjustable dipstick.

12.1.6 *Oil Filter Removal and Filter Dummy Installation*—After completion of Step C (see Table 6 and Table 7), shut the engine down (see 12.2.2). Remove the oil filter 20 min after stopping the engine. Install the oil filter *dummy* cap to the remote filter housing. Check and record the oil level. *Do not adjust the dipstick.* This oil level check is provided to establish the level of fuel dilution present after the break-in and should not be used for computing the overall test oil consumption.

12.2 Engine Operating Procedure:

12.2.1 *Engine Start-up*—Use the following detailed procedure each time the engine is started. (**Warning**—Before starting the engine, be sure there is an adequate supply of cooling water to the exhaust marine manifold. Without coolant flow, the marine manifold will overheat and sustain serious damage.)

12.2.1.1 Turn on the ignition, safety circuits, fuel management system, fuel pump, and the RAC coolant pump.

12.2.1.2 Set the fuel injector pulse width and connect the intake-air supply duct.

12.2.1.3 Crank the engine. After the engine has started, the pulse width should be returned to the Stage 3 setting at the earliest opportunity.

12.2.1.4 The fuel management, cranking, and throttle control systems should be set up to allow the engine to start within 10 s. Since spark ignition engines require a rich air-fuel ratio during startup, a Stage 1 or Stage 2 pulse width is normally necessary for hot and cold starts.

12.2.1.5 If starting difficulties are encountered, the laboratory should not continue to crank the engine excessively. Perform diagnostics to determine the reason the engine will not start (ignition problems, insufficient or excess fuel, and so forth). (**Warning**—Excessive cranking times can promote additional fuel dilution of the test oil and increased engine wear.) (**Warning**—In addition to other precautions, do not attempt to pour gasoline into the intake-air horn.)

12.2.2 Engine Shutdown:

12.2.2.1 *Scheduled Shutdown Procedure*—Follow the procedure detailed as follows each time a scheduled shutdown is performed. Scheduled shutdowns include shutdowns that occur during engine break-in and oil leveling:

- Bring the engine speed to 750 r/min.
- Switch the ignition off.
- Reduce the intake-air pressure to atmospheric.

12.2.2.2 *Unscheduled Engine Shutdown*—Follow the procedure detailed as follows each time an unscheduled engine shutdown is performed:

- Bring the engine speed to 750 r/min.
- Switch the ignition and RAC coolant pump off.
- Reduce the intake-air pressure to atmospheric.

12.2.3 Cyclic Schedule, General Description:

12.2.3.1 The test is composed of three stages as shown in Table 2. Together, the three stages comprise one cycle. Each cycle lasts 4 h and is repeated 72 times for a total of 288 h. Six consecutive cycles are completed each 24-h period. Every sixth cycle is modified to provide time for oil leveling (see A7.9).

12.2.3.2 Ramping requirements specifying parameter change rates are shown in Table 4. The rate of speed, temperature, and load changes, as well as the amount of enrichment between stages, can influence sludge and wear severity. Therefore, ramping rates are very important. Plot speed, load (torque), exhaust gas, CO, and O₂ levels during Transitions 2 to 3 and 3 to 1, as shown in Fig. A7.17. Record these parameters once during test hours 12 through 48 for all tests. If a stand calibration test is conducted, also record these parameters once during test hours 240 to 288. Format and scaling shall conform to Fig. A7.17.

12.2.4 *Unscheduled Downtime*—The 30-min oil leveling

periods are the only scheduled shutdown allowed during the test and are counted as test time. However, the test can be interrupted to perform necessary maintenance (see 12.3.6). All unscheduled downtime shall be noted in the final test report.

12.2.5 Lost Time—This is defined as time lost with respect to a master clock in an automatic control system. As an example, if the engine stalls but the master clock continues to run, the time that elapses between the engine stall and resumption under operating conditions is *lost time*. The test clock is restarted after the engine has reached operating conditions. *Lost time* shall not exceed 60 min total throughout the entire test. Make up *lost time* in the correct stages at some time during the test, and report it in the final test report.

12.2.6 Resumption of Test Time After Unscheduled Shutdown—After an unscheduled shutdown, test time does not begin until the engine has reached operating conditions.

12.3 Periodic Measurements and Functions:

12.3.1 Data Logging—Measure and record all data, except the specific parameters noted in this section, immediately prior to the midpoint and conclusion of Stage 1, the conclusion of Stage 2, and the conclusion of Stage 3. The format for the data logs is shown in Annex A5. Special considerations concerning computerized data acquisition are detailed in Annex A9.

12.3.2 Blowby Flow Rate Measurement—Measure and record the blowby flow rate during the second hour of Stage 1 of each cycle. The engine shall be stable at normal Stage 1 operating conditions. Measure blowby when the gas temperature is at least 90°F (32°C). Blowby gas temperature shall not differ from the laboratory average by more than $\pm 10^\circ\text{F}$ (5.6°C). The installation of the blowby flow rate measurement apparatus is shown in Fig. 7. The procedure for measuring blowby flow rate is detailed in 12.3.2.1. Normally, only one blowby flow rate measurement should be completed during each cycle. Additional blowby flow rate measurements are occasionally performed to determine or verify a problem with the flow rate measurement apparatus or the engine. Record additional blowby flow rate measurements and an explanation of the reason for the additional measurements. Include these data in the supplemental operational data in the final test report.

12.3.2.1 Measurement Procedure:

- (a) Open the bleeder valve completely.
- (b) Connect the bleeder line to the three-way valve.
- (c) Connect the hose from the blowby meter surge chamber to the 0.625-in. (15.9-mm) inside-diameter air vent hose on the intake horn.
- (d) Position the three-way valve to divert intake manifold vacuum from the engine PCV valve to the *dummy* PCV valve in the blowby measurement apparatus.
- (e) Connect the apparatus pressure sensor to the dipstick tube.
- (f) Adjust the bleeder valve to maintain crankcase pressure at 0.0 ± 0.1 in. H_2O (0 ± 25 Pa).
- (g) Record the differential pressure, blowby gas temperature, and the barometric pressure.
- (h) Disconnect the apparatus pressure sensor and reconnect the engine crankcase pressure sensor to the dipstick tube.
- (i) Disconnect the surge chamber hose from the air vent hose.

- (j) Position the three-way valve to divert intake manifold vacuum to the engine PCV valve and disconnect the bleeder line from the three-way valve.

- (k) Connect the air vent hose to the intake-air horn.

- (l) Calculate the blowby flow rate using the calibration data for the orifice. Correct the value to standard conditions using the following equation:

$$\text{Corrected blowby flow rate} = \text{blowby flow rate} \times (18.844 (P/459.67 + T))^{0.5} \quad (5)$$

where:

P = barometric pressure, in. Hg, and

T = blowby gas temperature, °F.

12.3.3 Ignition Timing Measurement—Measure and record the ignition timing at least once per two cycles in Stage 1, 2, or 3.

12.3.4 Exhaust Gas Analysis:

12.3.4.1 The recorded readings for exhaust gas CO and O₂ content are taken in accordance with the instructions in 12.3.1. However, the exhaust gas CO and O₂ content should be measured immediately after the engine oil and coolant temperatures have reached steady-state conditions in each stage (approximately 15 min into each stage). These data do not have to be recorded. The data are used to adjust the fuel management system to help ensure the engine is operated at the correct air-fuel ratio throughout each stage.

12.3.4.2 Measure and record the NO_x content of the exhaust gas during Stage 2 once every 24 h. The intent is to take subsequent readings after 24 h of run time have elapsed.

12.3.5 PCV Valve Replacement—Replace the PCV valve at 48, 96, 144, 192, and 240 h during the oil-leveling procedure (see 12.3.6.3). Retain the used PCV valves for possible after-test clogging measurements.

12.3.6 Oil Additions and Used Oil Sampling:

12.3.6.1 The test procedure provides a forced rate of oil consumption. Make oil additions at 12-h intervals, and take used oil samples at 24-h intervals. No other new oil additions are permitted during the test. Used oil additions are permitted only during engine reassembly for maintenance (see 12.4.2.2). The new oil addition and sampling procedure is detailed as follows. The procedure is shown in a flowchart format on the Oil Sampling, Addition and Leveling Worksheet in Fig. A5.1. This form serves as the oil sampling and oil addition data sheet.

12.3.6.2 Oil Sampling Procedure:

- (a) Pour 5 oz (150 mL) (fluid) of new oil in a beaker. Fifteen minutes after the engine has been switched to Stage 3, remove a 5-oz (150-mL) (fluid) purge sample into the beaker containing the new oil.

- (b) Remove a 2-oz (60-mL) (fluid) analysis sample from the engine. Label the sample bottle for identification of test number, date, test hour, and oil code (see 13.7).

- (c) Return the 10-oz (300-mL) (fluid) composite of new oil and purge oil to the engine at all sample hours except hour 288. Take precautions to prevent any oil loss.

- (d) Do not add new oil to the engine at hour 288. This allows the final drain to be used as a backup to the 288-h sample.

12.3.6.3 Oil Leveling Procedure:

- (a) After the engine is switched to Stage 3, add 5 oz (150

mL) (fluid) of new oil to the engine.

(b) Run the engine for 10 min at Stage 3 conditions.

(c) Switch the ignition off but leave the RAC coolant pump on.

(d) Bring the intake-air pressure to atmospheric.

(e) Measure and record the oil level 20 min after the engine is shut down.

(f) If the oil level is more than 12 fluid oz (360-mL) low during the first 192 h, invalidate the test because of excessive oil consumption. Use engineering judgment concerning test invalidation and termination if the oil level is more than 12 fluid oz (360-mL) low during the remainder of the test.

(g) If the oil level is above full mark, remove a sufficient quantity to bring the sump level to full.

(h) If the oil level is at or below the full mark, no leveling sample can be taken.

(i) Record all appropriate entries on the data log.

(j) Service the PCV valve in accordance with 12.3.5.

(k) Restart the engine 5 min before the scheduled beginning of Stage 1 and run the engine at Stage 3 speed and load.

(l) Resume the test at the scheduled beginning of the next cycle.

12.3.7 General Maintenance—The 30-min scheduled shutdown periods during oil leveling allow limited opportunity for engine and stand maintenance. In addition, the test can be shut down at any convenient time to perform unscheduled maintenance. However, the duration of a shutdown should be minimized. Report any unscheduled shutdown on the Special Maintenance Record. Report any attempts to restart the engine after stalling when resuming test conditions from a scheduled or unscheduled shutdown as additional *start attempts* on the Supplemental Operational Data Form, Fig A7.5.

12.4 Special Maintenance Procedures—Functions that require special maintenance procedures are listed in this section. These maintenance procedures are specifically detailed because of the effect on test validity or because they require special care while being completed.

12.4.1 Blowby Flow Rate Adjustment—The blowby flow rate can be adjusted if the cumulative average is projected to drift outside the specified limits. Adjust the blowby flow rate by increasing or decreasing the size of the compression ring gaps. Only two ring gap adjustments (one rering and one regap, or two regaps) may be performed during one test. Measure and record the existing ring gap dimensions before enlarging the gaps to calculate ring gap increase due to wear at the end of the test. Install a new set of torque-to-yield cylinder head bolts when reassembling the engine after the blowby flow rate adjustment. Specific limitations concerning high and low blowby flow rate adjustments are noted as follows. *If stuck rings are discovered during a rework, any corrective action such as freeing the stuck ring(s) shall be noted in the Special Maintenance section of the final test report. Note whether the ring(s) are cold or hot stuck.*

12.4.1.1 High Blowby Flow Rate Adjustment—An adjustment for high blowby flow rate can be performed only once and shall be completed during the first 48 h of the test. Reduce high blowby flow rate by replacing the compression rings with new rings that have smaller ring gaps.

12.4.1.2 Low Blowby Flow Rate Adjustment—Make adjustments for low blowby flow rate during the first 120 h of the test. A maximum of two adjustments for low blowby flow rate can be performed. Increase low blowby flow rate by increasing the ring gaps of the compression rings. Do not remove any deposits from the ring or ring land except those located in the ring gap.

12.4.2 Engine Disassembly and Reassembly for Maintenance (Before EOT):

12.4.2.1 When the engine is disassembled for maintenance, drain as much test oil as possible from the oil pan, and retain the oil for installation in the engine after reassembly. Take precautions to ensure the oil is not contaminated. Take precautions to ensure the deposits are not disturbed on any parts that are used to determine the final test results.

12.4.2.2 During reassembly, up to 6 oz (180 mL) (fluid) of the most recent, available oil-leveling sample may be used to lubricate the engine parts. Do not use EF-411 oil or new test oil during engine reassembly. After the engine has been reassembled, charge the oil pan with the oil removed from the oil pan during reassembly. Record all excess oil additions and report them in the Supplemental Operational Data.

12.4.3 Engine Pre-Lubrication Prior to Restart—Pre-lubricate the engine in accordance with 12.1.3 each time the oil charge has been removed from the engine or when the length of the shutdown exceeds 8 h.

12.4.4 Engine Parts Replacement—Parts that are rated to determine the final test results cannot be replaced during the test. The following parts can be replaced if necessary (record the circumstances involved in the replacement): engine camshaft drive belt, ignition system, PCV valve (see 12.5.5), seals and gaskets, valves or valve springs, fuel injectors, oil separator (PCV system), piston rings, and spark plugs.

12.5 Diagnostic Data Review—This section outlines significant characteristics of specific engine operating parameters. The parameters can directly influence the test or may be used to indicate normalcy of other parameters.

12.5.1 Intake Manifold Vacuum:

12.5.1.1 Intake manifold vacuum is affected by several factors, including engine load, air-fuel ratio, ignition timing, and engine wear. As a result, it is not a specifically controlled parameter but is used to monitor the condition of the engine.

12.5.1.2 The intake manifold vacuum normally decreases from Stage 1 to Stage 2, even though the engine speed, load, and lambda are the same. This is caused by the increased air temperature in the intake manifold reducing the density of the intake-air charge. The intake manifold vacuum generally increases during the first few cycles of the test, as the engine breaks-in. It may decrease toward the end of the test if the engine wears significantly. The target range offers adequate flexibility to account for differences in engine builds and barometric pressure. Operation outside of the target range suggests possible errors in load, ignition timing, exhaust gas composition, or combinations thereof.

12.5.2 Fuel Consumption Rate:

12.5.2.1 The fuel consumption rate should remain relatively constant throughout the test. Like intake manifold vacuum, fuel consumption rate is not a specifically controlled parameter but

is used as a diagnostics tool. In addition, fuel consumption rate and intake manifold vacuum relate to similar operating parameters.

(a) High fuel consumption rate can promote excessive cylinder bore, camshaft, and rocker arm wear. Maintain the fuel consumption rate below 18 lb/h (8.2 kg/h) throughout the entire test.

12.5.2.2 The fuel consumption rate is normally greater in Stage 1 than in Stage 2 even though the engine speed, load, and air-fuel ratio are the same. This is caused by the increased operating temperatures in Stage 2 that allow an increase in engine efficiency and a decrease in brake specific fuel consumption (bsfc). Excessive fluctuation of the fuel consumption rate at steady-state speed and load may indicate problems with the fuel management or fuel delivery systems.

12.5.3 *Spark Knock*—Spark knock does not normally occur in the VE test. The octane rating of the fuel, ignition timing, engine speed and load, and operating temperatures do not promote spark knock. Spark knock indicates abnormal combustion is occurring and can cause extensive engine damage. Take corrective action immediately if spark knock is noted. Errors in the measurement and control of engine load, ignition timing, operating temperatures, and air-fuel ratio may result in spark knock.

12.5.4 *Exhaust Gas Component Levels:*

12.5.4.1 The CO, O₂, and NO_x levels in the exhaust gas are used to determine the characteristics of combustion that occur during the test. Use these three parameters in conjunction to determine the normalcy of combustion and any significant changes in combustion that occur throughout a particular test.

12.5.4.2 Exhaust gas content measurements of CO and O₂ are used to ensure the engine is being operated at a specific lambda during a specific stage. Measurements of CO and O₂ are used because a specific lambda measurement has not been developed, and a numeric value for each lambda has not been determined. The lambda for each stage was chosen to produce specific effects. During Stages 1 and 2, the engine is operated at a lambda value greater than one (leaner than stoichiometric). This causes the engine to be operated at a relatively flat portion of the NO_x versus O₂ curve, near the point of maximum NO_x. During Stage 3, the engine is operated at a lambda value less than one (richer than stoichiometric). This helps dilute the crankcase oil with fuel. *The presence of components other than the component that is measured by a particular instrument can influence the accuracy of the measurement. The laboratory shall ensure the accuracy of the measurement of each specific component.*

12.5.4.3 Exhaust gas CO and O₂ content are useful indicators of various combustion and exhaust gas sampling problems. Content (CO) increases relatively linearly with decreasing lambda (increasing richness), for lambda values less than one (richer than stoichiometric). Content (O₂) increases relatively linearly with increasing lambdas for lambda values greater than one.

12.5.4.4 High CO levels indicate excess fuel is being introduced into the engine, while low CO levels indicate too little fuel is being introduced into the engine. High or erratic CO levels can be caused by a variety of problems, including an

air leak in the sampling system (The high CO results from excessive reduction of lambda to reduce the O₂ level.); PCV valve that is excessively clogged; or a problem with the fuel management system.

12.5.4.5 The presence of high O₂ levels and normal CO levels is usually caused by a slight misfire or a leak in the exhaust gas sampling or measurement system. The misfire can be caused by a plugged fuel injector or an ignition problem.

12.5.4.6 The VE test has been set up to produce significantly elevated exhaust gas NO_x levels when compared to a production engine. This raises the NO_x levels in the blowby gas and increases test severity. The NO_x levels should be consistent throughout a test and relatively consistent from test-to-test. Exhaust gas NO_x levels are primarily a function of combustion temperatures. As a result, the NO_x levels are influenced by several factors. The cylinder head, camshaft, ignition timing, and lambda have strong effects on NO_x levels. Load and engine operating temperatures have a smaller effect. Accurate NO_x measurement is very sensitive to sample flow rate.

12.5.5 *Crankcase Pressure*—Crankcase pressure is a function of blowby flow rate and PCV valve flow. High crankcase pressure is usually caused by high blowby flow rate or a significant loss of PCV valve flow. Incorrect three-way valve plumbing or port plugging also promotes high crankcase pressure. Low or negative crankcase pressure may be caused by low blowby flow rate or a restriction of vent air to the PCV valve.

12.5.6 *Oil Pressure:*

12.5.6.1 The oil pressure is a function of oil viscosity and operating temperature. The oil pressure will normally be highest in Stage 1 and lowest in Stage 3. The oil pressure should remain consistent throughout the test, unless the oil exhibits a significant increase in viscosity.

12.5.6.2 An excessive oil pressure differential between the pump output and engine gallery can indicate the presence of a restriction in the external system or a large bearing clearance. An excessive oil pressure differential between the engine gallery and head gallery indicates the presence of a gallery restriction at the head gasket or an increased oil flow rate to the valve deck. When the engine gallery-to-head gallery differential pressure is lower than normal, camshaft lobe orifice plugging is indicated, causing a reduction in oil flow rate through the camshaft.

12.5.7 *Oil Temperature Differential*—The oil temperature differential is primarily a function of oil flow rate and oil viscosity and is normally stable throughout the test. The differential can increase if the oil viscosity increases significantly during the test.

12.5.8 *Coolant Temperature Differential*—The coolant temperature differential is primarily a function of the coolant flow rate and is normally stable throughout the test. Large variations in the differential can be caused by coolant flow rate or temperature measurement errors. Coolant flow rate measurement errors can be caused by foreign objects in or near the venturi flowmeter.

12.6 *End of Test Procedure:*

12.6.1 *Engine Removal*—Drain the engine and RAC coolant immediately after the completion of the last test cycle. Do

not drain the engine oil. Remove the engine from the test stand and allow the engine to stand for 6 h in the same attitude in which it was positioned on the test stand. This allows the oil to drain completely into the oil pan.

12.6.2 Final Oil Drain and Engine Disassembly—Drain the oil completely and disassemble the engine. During disassembly, use extreme care to ensure the original location of the parts can be identified with respect to the cylinder number or valve location, or both.

12.6.3 Parts Layout for Rating:

12.6.3.1 Arrange the following parts in the parts rating area in accordance with the layouts detailed in this section. A photograph of the parts layout is shown in Fig. A6.12. After the parts have been arranged, allow the parts to drain a minimum of 4 h before rating. Do not attempt to accelerate or force the oil draining. Any fixtures can be used to support the parts as long as they orient the parts in the specified configurations.

12.6.3.2 RAC—Position the RAC vertically (upper jacket surface perpendicular to the ground) with the front of the RAC pointing down.

12.6.3.3 Camshaft Baffle—Position the camshaft baffle vertically (top baffle surface perpendicular to the ground) with the rear of the camshaft baffle pointing down.

12.6.3.4 Cylinder Head—Position the cylinder head with exhaust port surface pointing down. The exhaust manifold studs should be left in the head to raise the head off of the supporting surface and allow drainage.

12.6.3.5 Front Seal Housing—Position the front seal housing in the same orientation as it is installed in the engine.

12.6.3.6 Oil Pan—Position the oil pan upside down, at a 45° angle, with sump end pointing down.

12.6.3.7 Oil Screen and Pickup Tube—Position the oil screen and pickup tube in the same orientation as it is installed in the engine. The screen should be raised off of the supporting surface to allow drainage. A fixture is necessary to support the oil screen and pickup tube.

12.6.3.8 Engine Block—Position the engine block with the valve deck in a horizontal plane and facing the ceiling.

13. Interpretation of Results

13.1 Parts Rating Area—Environment:

13.1.1 Ensure that the ambient atmosphere of the parts rating area is reasonably free of contaminants, and that the temperature is maintained at 75 ± 5°F (24 ± 3°C). When a rater seeks advice from another rater, report the rating as a consensus rating in the final report. Do not use raters from outside sources (other laboratories) for consensus ratings and do not average these ratings. Include independent ratings in the supplemental pages as information only.

13.1.2 Rate all engine parts except the pistons, RAC, and cylinder block under cool white fluorescent lighting exhibiting approximately 4500 K color temperature, and an illumination level of 350 to 500 fc (3800 to 5400 lx). All background and adjacent surfaces shall be flat white.

13.1.3 Rate pistons and RACs against a white background using white fluorescent bulbs and a 100 % white deflector. Maintain the illumination level between 350 and 600 fc (3800 to 6500 lx), and measure the illumination level 14 in. (360 mm) from the desk top. Provide a 15-W bore light with a cool white

fluorescent tube for the cylinder wall varnish rating.

13.2 Sludge Ratings:

13.2.1 Rate the following parts for sludge deposits: RAC, valve deck, cylinder block, camshaft baffle, front seal housing, and oil pan. Use the rating locations identified on the rating worksheets (see Annex A6). Determine the ratings using the techniques detailed in CRC Manual No. 12. Adjust RAC sludge on candidate tests for laboratory severity in accordance with Annex A12.

13.2.2 Average Sludge (Unweighted Average of All Six Parts):

13.2.2.1 Use the self-weighting procedure detailed as follows to determine the sludge rating for each part. Adjust the average sludge on non-reference tests for laboratory severity in accordance with Annex A12.

(a) Determine the sludge depth at each of the sites shown on rating worksheets. A site is defined as a 0.75-in. (19.1-mm) diameter circle.

(b) Determine an interpolated sludge value for a designated site that exhibits more than one level of sludge depth within this area. This value is generated by multiplying each rated value's volume factor by the percentage of area covered, totaling these volume factor percentages, and comparing the total to the values given in Table 8 to determine the rating for the site. As an example, if a site was determined to be 50 % A and 50 % E, the calculation would be: 50 % of the average sludge depth factor for A (or 1.0), plus 50 % of the average sludge depth factor for E (or 16.0); that is: $([0.5 \times 1.0 = 0.5] + [0.5 \times 16.0 = 8]) = 8.5$, and the calculated site sludge depth would be a D. In the event that there are areas where it is apparent that deposits had formed, but are no longer adhering to the part, the rating site is the closest point to the designated point that will eliminate the voided area from the 0.75-in. (19.1-mm) rating area.

(c) Add the total rating checks made for each line on the appropriate worksheets. These shall equal 10 or 20, depending on the part that is rated.

(d) Multiply the total rating checks made on each line by ten or five, respectively (refer to (c)), to obtain the percent covered by the rated sludge depth. The grand total shall equal 100 %.

(e) Convert the percent covered by the rated sludge depth at each location to a volume factor using the procedure shown in CRC Manual No. 12.

(f) Add the volume factors on each line to determine the total volume factor. Use CRC Manual No. 12 to convert the total volume factor to the sludge merit rating.

TABLE 8 Average Sludge Site Ratings

Total	Site Ratings	Total	Site Ratings
<0.125	Clean	≥3.500 <6.000	C
≥0.125 < 0.375	¼ A	≥6.000 < 12.00	D
≥0.375 < 0.625	½ A	≥12.00 < 24.00	E
≥0.625 < 0.875	¾ A	≥24.00 < 48.00	F
≥0.875 < 1.250	A	≥48.00 < 96.00	G
≥1.250 < 1.750	AB	≥96.00 < 192.0	H
≥1.750 < 2.500	B	≥192.0 < 384.0	I
≥2.500 < 3.500	BC	≥384.0	J

13.2.2.2 *Flaky, Bubbly Sludge Deposits*—Since the occurrence of flaky, bubbly sludge deposits is thought to have a possible detrimental effect on long-term engine lubrication system performance, document the occurrence of this type of deposit in the Supplemental Operational Data section of the Final Test Report. The type of information to be recorded is the engine part(s) where this type of deposit was observed. Suggested wording is as follows: Approximately 6 % of the RAC was found to exhibit flaky, bubbly sludge deposits.

13.3 Varnish Ratings:

13.3.1 *Preparation of Parts*—Rate the following parts for varnish deposits: piston skirts, camshaft baffle, oil pan, rocker arm cover, and cylinder walls. Perform the varnish ratings after the sludge ratings are completed. The rating locations and dimensions shall conform with the locations and dimensions detailed on the rating worksheets (see Annex A6). Avoid disturbing sludge deposits when the parts are being prepared for varnish ratings. Heavy sludge can be removed from a varnish rating area with a 1-in. (25-mm) rubber spatula prior to wiping. Wipe all parts firmly with wiping materials specified in CRC Manual No. 14. Firmly rub all wiping areas in the same direction until the surface is dry and free of sludge (until no more deposit is present on the wiping material after wiping).

13.3.2 *Average Varnish (Unweighted Average of the First Five Parts)*—Use the procedure detailed as follows to determine the varnish rating of each part:

13.3.2.1 Rate any areas where varnish deposits have been altered during disassembly or sludge removal in accordance with deposits on the surrounding non-altered areas. Do not rate altered areas as *clean*.

13.3.2.2 Determine varnish ratings of all parts except pistons by comparison of the deposit on the rating location with color chips. The piston photographs shown in CRC Manual No. 14 shall be used to determine the varnish ratings on the pistons.

13.3.2.3 Determine the average varnish rating over each area specified in the rating worksheets. Adjust piston skirt varnish ratings on all tests completed after May 1, 1993, by adding 0.15 to the average piston varnish rating. Adjust piston skirt varnish ratings on candidate tests for laboratory severity in accordance with Annex A12.

13.3.2.4 Determine the average varnish rating of the entire part.

13.4 Clogging:

13.4.1 *Oil Screen Clogging*—Determine the percentage of the total screen opening that is obstructed with sludge and debris.

13.4.1.1 Flexible, transparent rating aids can be made for different surface areas so that when compared to the test screen's surface, a more accurate determination of surface clogging is possible. These are made of thin, colored transparent plastic cut into circles equivalent in area to 20, 10, and 5 % (1.5, 1.125, and 0.75 in. [38.1, 28.6, and 19.1 mm] in diameter, respectively) of the 9.5 in.²(6130 mm²) flow surface.

13.4.1.2 If there is any question concerning whether the screen is covered with oil or sludge, blow lightly on the screen (see CRC Manual No. 12). Note an analysis of deposits identified as debris in the Supplemental Operational Data.

13.4.2 *Oil Ring Clogging*—Determine the percentage of slot clogging for each oil ring in accordance with the procedure detailed in CRC Manual No. 12. Calculate and record the average clogging for all four rings.

13.4.3 *PCV Valve Clogging*—Determine the percent clogging of the PCV valve that is used during the last 48 h of the test, in accordance with the following procedure:

13.4.3.1 Measure the PCV valve flow rate at differential pressures from 8 and 18 in. Hg (13.5 and 60.8 kPa). Calculate the percent clogging in accordance with the following equation:

$$\text{PCV valve clogging, \%} = \frac{I - F}{I} \times 100 \quad (6)$$

where:

I = initial flow rate, and

F = final flow rate.

13.4.3.2 If any of the PCV valves have been replaced before the scheduled replacement interval, calculate and report the PCV valve clogging for all of the PCV valves. Report the percent clogging of the last valve on the Ratings and Measurements Page.

13.4.4 *Camshaft Lobe Orifice Clogging*—Determine the camshaft lobe orifice clogging with the camshaft lobe orifice flow rate device (see 7.5.3 and Figs. A3.32 and A3.33) in accordance with the following procedure:

13.4.4.1 Connect the apparatus to a source of compressed air.

13.4.4.2 Adjust the two pressure regulators until the probe pressure is 10 in. water (2.5 kPa).

13.4.4.3 Calibrate the apparatus by measuring the flow rate when the probe pressure is 10.0 ± 0.2 in. water (2.49 ± 0.05 kPa) and the probe is firmly seated in the calibration lobe orifice (clean orifice) with the probe pressure adjusted to 10.0 ± 0.2 in. water (2.49 ± 0.05 kPa). Record the flow rate as *Baseline Flow Rate* on the rating worksheet.

13.4.4.4 Firmly seat the probe in each lobe hole, adjust the probe pressure to 10 ± 0.2 in. water (2.49 ± 0.05 kPa), and record the flow rate.

13.4.4.5 Calculate and record the percent flow rate reduction in accordance with the following equation:

$$\text{camshaft lobe orifice flow rate reduction, \%} = \frac{I - F}{I} \times 100 \quad (7)$$

where:

I = initial flow rate, and

F = final flow rate.

13.4.4.6 Record the number of clogged camshaft lobe orifices. Clogged orifices are defined as orifices having a flow rate reduction greater than 80 %.

13.5 Sticking:

13.5.1 *Compression Rings*—Record the number of stuck compression rings. Definitions to classify the degree and type of sticking are detailed in Section 3. List only hot stuck compression rings on the Ratings and Measurements Summary page. Denote hot or cold stuck rings on the Supplementary Operational Data page and include the ring location (top or second) and the piston number.

13.5.2 *Hydraulic Lifter Plungers*—Record the number of

hydraulic lifter plungers that are completely stuck in the lash adjuster bodies. Note partially stuck plungers on the final engine inspection sheet.

13.6 *Wear Measurements:*

13.6.1 *Camshaft Lobe Wear*—Measure and record the heel-to-toe measurement of each camshaft lobe at the maximum lift point using a device reading directly in micrometres, with an accuracy of at least $\pm 3 \mu\text{m}$. Calculate the wear based on the before-test measurements.

NOTE 11—The +0.14 adjustment replaces the +0.24 adjustment. Do not apply both adjustments.

13.6.1.1 For reference oil tests completed on or after May 16, 1996, add 1.451 to the transformed average cam wear result and 1.693 to the transformed maximum cam wear result. Until a reference oil test is conducted on or after May 16, 1996, do not add 1.451 and 1.693 to average and maximum cam wear non-reference oil test results. Adjust wear results for laboratory severity in accordance with Annex A12.

13.6.2 *Rocker Arm Wear*—Wash the rocker arms with aliphatic naphtha. Wash the rocker arms with ethyl acetate and allow the rocker arms to air dry. Weigh the rocker arms and calculate the weight loss based on the before-test weights.

13.6.3 *Connecting Rod Bearing Wear*—Wash the bearings in aliphatic naphtha. Dip the bearings in pentane and allow the bearings to air dry. Measure the bearing weights. Calculate the weight loss based on the before-test measurements. The bearing weight loss is the total loss for two halves of each bearing.

13.6.4 *Piston Ring Gap Increase*—Clean the ring ends thoroughly and measure the ring gap after the rings have been installed in the block (see 7.8, 11.2). Calculate the ring gap increase. Compensate for any ring gap adjustments made during the test.

13.6.5 *Cylinder Bore Wear*—Measure the transverse bore wear at the top, middle, and bottom of the second compression ring travel, using the technique specified in 7.8.9.5 (a). Measure the bores with both stress plates installed. Calculate wear based on the before-test versus after-test measurements.

13.7 *Used Oil Analysis:*

13.7.1 Perform the following analyses on the used oil samples from hours 0 (new oil), 12, 108, 204, and 288: Iron content, ppm; copper content, ppm; silicon content, ppm; and kinematic viscosity at 40°C, cSt (in accordance with Test Method D 445).

13.7.2 *Fuel Dilution*—Determine the fuel dilution, percent mass, by gas chromatography (see Test Method D 3525, with the following modifications) on the used oil samples from hours 12, 108, 204, and 288:

13.7.2.1 Use C16 in place of C14 for the internal standard (1-L injector volume).

13.7.2.2 Presume that all components lighter than C16 are fuel.

13.7.2.3 The integrator should establish a horizontal baseline under the output curve until the leading edge of C16 is reached. Establish a second baseline extending horizontally from the output curve, at the intersection of the output curve, and the leading edge of the C16 peak.

13.7.2.4 Column details are 10 ft by 0.125 in. (305

cm \times 3.2 mm) SS; and the packing material is 5 % OV-1 on Chromosorb W HP.

13.7.2.5 Increase the oven temperature from 60 to 320°C, with the rate of change of temperature controlled at 8°C/min. Hold the temperature at 320°C for 16 min to elude oil.

13.7.3 *Insolubles*—Perform the following analysis on the used oil samples from Hours 108, 204, and 288: pentane insolubles. (See Test Method D 893B, pentane only.)

13.7.4 *Substitute Samples*—Samples from hours 36, 132, and 228 can be substituted if the sample from the previous sampling period has been misplaced (see Fig. A7.9).

13.8 *Other Deposits:*

13.8.1 *Piston Undercrown*—Determine the deposit rating of the piston undercrown by comparison of the deposit on the rating location with CRC Induction System Rating Technique contained in CRC Manual No. 16. Rate any areas where deposits have been altered by disassembly in accordance with deposits on the adjacent non-altered areas. Do not rate altered areas as clean. Identify the percentage of altered area on Fig. A7.1.5.

13.8.2 *Ring Land Deposits*—Determine the deposit rating of the ring land faces on all four pistons for each land type: crown land, second land (area between the two compression rings), and the oil ring land (area directly above the oil ring) by comparison of the deposit on the rating location with color chips contained in CRC Manual No. 14 (non-rubbing scale, Appendix A.51). Average the results for each land type from each of the four pistons. Rate deposits that are less than 1.0 merits using two levels of carbon, heavy carbon, and light carbon. Heavy carbon is carbon that has more buildup when compared with adjacent surfaces and has a polished or rubbed finish. Assign a merit value of 0.0 to areas of heavy carbon. Rate all other deposits as light carbon and assign a merit value of 0.75 to those areas. Rate any areas where deposits have been altered by disassembly in accordance with deposits on the adjacent non-altered areas. Do not rate altered areas as clean. Identify the percentage of altered area on Fig. A7.1.5.

14. Assessment of Test Validity

14.1 The testing laboratory shall assess the validity of tests that have deviations from the procedure. The TMC will assist the laboratory in the determination of calibration test validity, if requested by the laboratory. Use the following guidelines as a basis for determining test validity:

14.2 *Average Exhaust Gas NO_x Levels*—The average NO_x level during a test should be within 600 ppm of the overall cumulative calibration test average for the laboratory. The cumulative calibration test average is the average NO_x level of the last ten calibration tests. Significantly lower NO_x levels could cause a reduction in sludge severity.

14.3 *Used Oil Analyses—Interpretation:*

14.3.1 *Iron and Copper Content*—The iron and copper content of the used oil samples can indicate the level of wear that occurs during a test. Increased camshaft, rocker arm, and cylinder bore wear causes the iron content to increase. High levels of iron may also increase sludge severity. The rate of change in iron levels indicates the rate of change of wear levels, although wear tends to be linear throughout the test. Copper levels tend to be relatively stable unless excessively

high levels of connecting-rod bearing weight loss are experienced.

14.3.2 *Silicon Content*—Silicon content indicates the level of contamination of the oil from external sources and silicone-based sealers. Silicone-based sealers are used near the rear crankshaft seal housing to seal the oil pan. Investigate the presence of silicone-based sealers, the cleanliness of engine parts during build-up, the cleanliness of the intake-air, and the cleanliness of containers used for dispensing and sampling the oil if high levels of silicone are experienced.

14.3.3 *Fuel Dilution*—Fuel dilution indicates the degree to which the crankcase oil has been diluted with fuel. Fuel dilution of the crankcase oil is necessary to achieve adequate test severity. However, excessive fuel dilution may promote increased wear and sludge severity. The reproducibility of fuel dilution tends to be poor. Therefore, fuel dilution levels should only be compared to other results obtained from the same analytical laboratory, using the same analytical equipment and technique. Investigate a higher level of fuel dilution than is normally noted.

14.4 *Blowby Flow Rate:*

14.4.1 The corrected average blowby flow rate shall fall within the range from 1.75 to 2.25 cfm (0.83 to 1.06 L/s). In addition, the requirements listed in 14.3.2 shall also be met.

14.4.2 Between 48 and 192 h, a maximum of twelve corrected blowby flow rate readings may be greater than 2.25 cfm (1.06 L/s). Between 48 and 192 h, the summation of the deltas (delta = [corrected reading in cfm] - 2.25) of blowby flow rate readings above 2.25 cfm are not to exceed 1.2. No more than 16 of the corrected blowby flow rate readings can be less than 1.75 cfm (0.83 L/s) during the first 192 h. The summation of the deltas (delta = 1.75 - [corrected cfm]) of blowby flow rate readings below 1.75 cfm (0.83 L/s) are not to exceed 1.6 during the first 192 h.

14.5 *Intake Manifold Vacuum*—Depending upon an individual laboratory, intake manifold vacuum will vary in accordance with the altitude of the laboratory, ambient barometric pressure, and the mechanical efficiency of the engine. Laboratories should investigate intake manifold vacuum readings that are abnormal for their laboratory. Abnormal readings can be due to measurement errors in manifold vacuum, engine build, exhaust back pressure, engine speed, engine load, and air-fuel ratio.

14.6 *Fuel Consumption Rate*—The fuel consumption rate should not exceed 18 lb/h (8.2 kg/s) at any time during the test.

14.7 *Oil Consumption*—The final oil level cannot be lower than 12 oz (360 mL) (fluid) during the first 192 h of the test. Use engineering judgment concerning test invalidation if the oil level is lower than 12 oz (360 mL) during the remainder of the test.

14.8 *Shutdowns*—The number of shutdowns are to be minimized. Under no circumstances is the number of shutdowns to exceed twelve, exclusive of shutdowns for blowby flow rate adjustments and scheduled oil level shutdowns. Length of downtime is to be minimized, and under no circumstances is the total length of downtime to exceed 100 h.

14.9 *Deviation Percentage*—Calculate the deviation percentage in accordance with the following equation:

$$DP = \sum_{i=1}^{i=n} \left[\frac{M_i}{0.5R} \times \frac{T_i}{D} \right] \times 100 \tag{8}$$

where:

- DP = deviation, %,
- M_i = magnitude of test-parameter deviation from specification limit at occurrence *i*,
- R = test parameter specification range,
- T_i = length of time that test parameter was outside of specification range at occurrence *i*,
- n = number of times that a test parameter deviated from test specification limits, and
- D = length of test-phase duration in same units as T_i.

NOTE 12—T_i is assumed to be no less than the recorded-data-acquisition frequency unless supplemental readings are documented.

14.10 Invalidate any tests exceeding the following deviation percentages:

Primary test parameter	2.5 %
Secondary test parameter	5.0 %

14.10.1 *Primary Parameters:*

Primary Parameters	Divisor (D)
Oil inlet temperature	288
Coolant outlet temperature	288
Timing	288
Exhaust gas oxygen (Stages I and II)	234
Exhaust gas CO (Stage III)	48

14.10.2 *Secondary Parameters:*

Secondary Parameters	Divisor (D)
Engine Speed	288
Power	288
Rocker arm cover coolant flow rate (Stages I and III)	198
Exhaust back pressure (Stages I and II)	234

14.10.3 *Special*—For tests started prior to September 1, 1992, invalidate the test if the deviation percentage for either engine coolant flow rate or rocker arm cover inlet coolant temperatures exceeds 5.0 %. For tests started on or after September 1, 1992, invalidate the test if the deviation percentage for either parameter exceeds 2.5 %.

14.10.4 *Special Parameters:*

Special Parameters	Divisor (D)
Coolant flow rate	144
Rocker arm cover inlet	288

14.11 *Mid Specification Operation*—For all tests started on or after September 1, 1992, invalidate the test if the average of steady state operating data for a controlled, primary parameter is offset from the target mean by more than 12.5 % of the allowable control range. For tests started on or after March 30, 1992, list in the test report any parameters that fall outside of these limits.

Example: Temperature specification is 100 ± 2°

Primary: Average must be within 100 ± 0.5°

Secondary: Average must be within 100 ± 1.0°

14.11.1 *Primary Parameters:*

Primary Parameters	Stage/Range
Oil inlet temperature (°F)	Stage 1 155 ± 0.5

	Stage 2	210 ± 0.5
	Stage 3	115 ± 0.5
Coolant outlet temperature (°F)	Stage 1	125 ± 0.5
	Stage 2	185 ± 0.5
	Stage 3	115 ± 0.5

14.11.2 Secondary Parameters:

Secondary Parameters	Stage/Range	
Engine speed (r/min)	Stage 1 and 2	2500 ± 5
	Stage 3	750 ± 12.5
Power (bhp)	Stage 1 and 2	33.5 ± 0.25
	Stage 3	1.0 ± 0.25
Rocker arm cover coolant flow rate (gpm)	Stage 1 and 3	2.0 ± 0.1

14.12 *Stage Transitions*—Invalidate any test that does not meet the speed, torque, CO, and O₂ values listed in Table 4 during transition from Stage 2 to 3 and Stage 3 to 1.

15. Report

15.1 *Report Format*—The various required sections and specific details concerning the format of the report are outlined in this section. Examples of each section are shown in Annex A5 and Annex A7. Deviations in the format are generally not permitted. However, deviations in nomenclature and other details may be permitted. Any desired deviations shall be approved by the TMC. Calibration data for particular reference oils are available from the TMC.

15.2 *Special Forms for Automated Data Acquisition*—Automated data acquisition systems may require the use of forms that differ from those shown in Annex A5 and Annex A7. Variations in forms for automated data acquisition systems shall be approved by the TMC.

15.3 *Standard Report*—Include the following sections in the standard test report. Begin each section on a new page and insert the sections in the following order:

- 15.3.1 Title page (includes validity statement—Fig. A7.1),
- 15.3.2 Ratings and measurements summary (Fig. A7.2),
- 15.3.3 Calibration test ratings and measurements summary (Fig. A7.3),
- 15.3.4 Operational summary (Fig. A7.4),
- 15.3.5 Supplemental operational data (Fig. A7.5),
- 15.3.6 Special maintenance record (Fig. A7.6),
- 15.3.7 Oil analyses (Fig. A7.7),
- 15.3.8 Valve train inspection detail (Fig. A7.8),
- 15.3.9 Piston skirt varnish rating breakdown (Fig. A7.9),
- 15.3.10 Corrected blowby flow rate plot (Fig. A7.10),
- 15.3.11 Oil addition record (Fig. A7.11),
- 15.3.12 Origin of significant engine parts (Fig. A7.12),
- 15.3.13 Characteristics of the data acquisition system (Fig. A7.13),
- 15.3.14 RAC and camshaft baffle photographs (Fig. A7.14),
- 15.3.15 Oil pan and screen photographs (Fig. A7.15),
- 15.3.16 Piston skirt photographs (Fig. A7.16),
- 15.3.17 Camshaft lobe photographs (Fig. A7.17),
- 15.3.18 Front seal housing photographs (Fig. A7.18),
- 15.3.19 Report speed, torque, and exhaust gas CO output during transition, including limits in Table 4 (in accordance with 12.2.3.2) in the format of Fig. A7.19. Take data during test hours 12 through 48. Include copies of the transition plots from the previous stand reference test with each candidate test run.

If adjustments are needed to bring the transition into conformance with the requirements of Table 4, include a plot conducted after the adjustment, showing conformance to Table 4 criteria. Where additional plots are required, the last plot may be taken through test hour 64.

15.3.20 Ring adjustment summary, includes cylinder bore wear (Fig. A7.20),

15.3.21 Deviation percentage summary (Fig. A7.21),

15.3.22 Mid limit specification summary (Fig. A7.22),

15.3.23 Engine operational and special maintenance data log (Fig. A7.4).

15.4 *Calibration Test Report*—Include the following sections in the calibration test report. Begin each section on a new page and insert the sections in the following order:

15.4.1 Title page (includes validity statement—Fig. A7.1),

15.4.2 Calibration test ratings and measurements summary (Fig. A7.3),

15.4.3 Operational summary (Fig. A7.4),

15.4.4 Supplemental operational data (Fig. A7.5),

15.4.5 Special maintenance record (Fig. A7.6),

15.4.6 Oil analyses (Fig. A7.7),

15.4.7 Valve train inspection detail (Fig. A7.8),

15.4.8 Piston skirt varnish rating breakdown (Fig. A7.9),

15.4.9 Corrected blowby flow rate plot (Fig. A7.10),

15.4.10 Oil addition record (Fig. A7.11),

15.4.11 Origin of significant engine parts (Fig. A7.12),

15.4.12 Characteristics of the data acquisition system (Fig. A7.13),

15.4.13 Rocker arm cover and camshaft baffle photographs (Fig. A7.14),

15.4.14 Oil pan and screen photographs (Fig. A7.15),

15.4.15 Piston skirt photographs (Fig. A7.16),

15.4.16 Camshaft lobe photographs (Fig. A7.17),

15.4.17 Front seal housing photographs (Fig. A7.18),

15.4.18 Report speed, torque, and exhaust gas CO output during transition, including limits in Table 4 (in accordance with 12.2.3.2) in the format of Fig. A7.19. Take data during test hours 12 through 48. Include copies of the transition plots from the previous stand reference test with each candidate test run. If adjustments are needed to bring the transition into conformance with the requirements of Table 4, include a plot conducted after the adjustment, showing conformance to Table 4 criteria. Where additional plots are required, the last plot may be taken through test hour 64.

15.4.19 Ring adjustment summary, includes cylinder bore wear (Fig. A7.20),

15.4.20 Deviation percentage summary (Fig. A7.21),

15.4.21 Mid limit specification summary (Fig. A7.22),

15.4.22 Engine operational and special maintenance data log (Fig. A7.4, Fig. A7.5, and Fig. A7.6).

15.5 *Photographs*—The required photographs are listed in this section and shown in Fig. A7.14 through Fig. A7.18. These figures depict the headings and the recommended orientation of the photographs. Digital images, comparable in pictorial quality to photographs, may be used instead of photographs.

15.5.1 RAC,

15.5.2 Front seal housing,

15.5.3 Camshaft baffle,

- 15.5.4 Oil pick-up screen,
- 15.5.5 Oil pan,
- 15.5.6 Average and worst piston, anti-thrust sides,
- 15.5.7 Average and worst piston, thrust sides,
- 15.5.8 Best camshaft lobe (lowest wear),
- 15.5.9 Worst camshaft lobe (highest wear), and
- 15.5.10 Best and worst camshaft follower (lowest and highest wear).

16. Precision and Bias

16.1 Precision:

16.1.1 *Non-Reference Oils*—To aid the potential user of this test method to assess the variability that can be expected between test results when the test method is used in one or more reasonably competent laboratories, the precision information in Table 9 has been developed:

16.1.1.1 The non-reference oil precision for this test method is determined by the statistical analysis of sets of data submitted by users of the test method. Each set of data consists of two or more engine test results, obtained on the same engine oil formulation. Each data set may be from tests run in the same laboratory or different laboratories, and with any approved fuel batch. The data are collected and analyzed by

industry volunteers, and reported to the ASTM Sequence VE Test Method Surveillance Panel.

16.1.1.2 The statistical criteria summarized in Table 9 represents the estimate of *Reproducibility*, based on 250 df obtained over the period of April 1, 1992, through September 30, 1994, for the various required engine deposit and wear performance parameters. This reasonably long time period was selected as being representative of a consistent period of test operation. (If a potential user has a desire to know what the most recent precision data are for non-reference oils, the TMC can provide this information by consulting the appropriate Sequence VE Surveillance Panel meeting minutes.)

16.1.1.3 *Reproducibility (R)*—The difference between two single and independent results obtained on the same oil by different operators working in different laboratories would, in the long run, in the normal and correct conduct of the test method, exceed the values in Table 9 in only one case in twenty.

16.1.1.4 No similar estimate of non-reference oil *Repeatability* is available with this test method since the number of non-reference oil tests repeated in the same engine, test stand, and laboratory are limited. An estimate of current *Repeatability* is contained in the statistical reference oil data base maintained by the TMC.

16.1.2 *Reference Oils*—The TMC uses the precision information developed from frequent tests on several reference oils to help those laboratories conducting the test method maintain consistent test severity. These precision data are updated regularly and are available upon request from the TMC. The reference oil precision from operationally valid tests from April 1, 1992, through September 30, 1994, is summarized in Annex A11.

16.2 *Bias*—Bias is determined by applying an accepted statistical technique to reference oil test results, and when a significant bias is determined, a severity adjustment is permitted for non-reference oil test results (see 13.2.1, 13.3.2.3, and Annex A12).

TABLE 9 Non-reference Oil Precision Statistics^A

Variable	Measured Units	
	Reproducibility ^B	
	S_R^C	R^D
Average engine varnish, merits	0.35	0.98
Average piston varnish, merits	0.25	0.70
Variable	Transformed Units	
	Reproducibility ^B	
	S_R^C	R^D
Average engine sludge, - ln (9.65-merits)	0.56	1.57
Rocker cover sludge, - ln (9.65-merits)	0.51	1.43
Average cam wear, - (mils)	0.71	1.60
Maximum cam wear, ln (mils)	1.02	2.86

^A These statistics are based on non-reference oil test results obtained over the period of April 1992 through September 1994.

^B Reproducibility values refer to tests run on the same oil in different laboratories.

^C S_R = Standard deviation.

^D On the basis of test error alone, the difference, in absolute value, between two test results will be expected to exceed this value about 5 % of the time. This value is obtained by multiplying the reproducibility standard deviation (S_R) by 2.8.

17. Keywords

17.1 lubricating oils; Sequence VE; sludge and varnish; spark-ignition automotive engine; stop-and-go service; valve train wear

ANNEXES

(Mandatory Information)

A1. SPECIAL SERVICE TOOLS FOR THE TEST ENGINE

A1.1 See Table A1.1.

TABLE A1.1 Special Service Tools for the Test Engine

Tool Number	Description
T74P-6000LA	2.3 L service tool kit
T74P-6015-A	engine plug replacer
T74P-6019-B	front cover alignment tool
T68P-6135-A	piston pin remover/replacer
T74P-6136-A	crankshaft timing gear remover/adaptor
T74P-6150-A	camshaft and auxiliary shaft seal replacer
T71P-6250-A	camshaft bearing replacer
T74P-6254-A	camshaft belt tension adjusting tool
T74P-6256-B	camshaft and auxiliary shaft glide hammer sprocket tool
T59L-100-B	slide hammer
T74P-6375-A	flyway holding tool
T74P-6565-A	valve spring compressor
T73P-6571-A	valve seal installer
T79P-6634-A	pressure diagnostic gage
T74P-6700-B	front cover seal remover
T82L-6701-A	crankshaft seal installer
D79L-6731-B	oil filter wrench
T71P-7137-C	pilot bearing replacer
T71P-7137-H	clutch aligner
T77L-9533-B	jet plug remover/small
T58L-101-A	puller attachment
T74P-6306-A	crankshaft timing gear tool
T74P-6312-A	crankshaft damper remover

A2. EXTERNAL OIL HEAT EXCHANGER CLEANING TECHNIQUE

A2.1 Remove and completely disassemble the heat exchanger including the end caps.

A2.2 Flush the shell side of the heat exchanger with an organic solvent for a minimum of 12 h to ensure the removal of all deposits. This can be accomplished by using a positive displacement pump to flow the solvent through the heat exchanger at a flow rate of 10 ± 2 g/min (0.63 ± 0.126 L/s). Several heat exchangers can be flushed at the same time by connecting them in series. Flushing can be required for longer than 12 h if the deposits are particularly heavy or the solvent is aged. Filtration of the solvent can extend the useful life of the solvent.

A2.3 Rinse the heat exchanger with hot water.

A2.4 Rinse the heat exchanger with aliphatic naphtha.

A2.5 Air dry the heat exchanger.

NOTE A2.1—The tube side of the heat exchanger should be periodically cleaned to ensure adequate heat transfer. A rifle bore cleaner attached to an electric drill has been found to be an effective way to remove process water deposits. Ultrasonic cleaning is also effective in this application.

A3. DETAILED SPECIFICATIONS AND PHOTOGRAPHS OF APPARATUS

A3.1 See Figs. A3.1-A3.48.

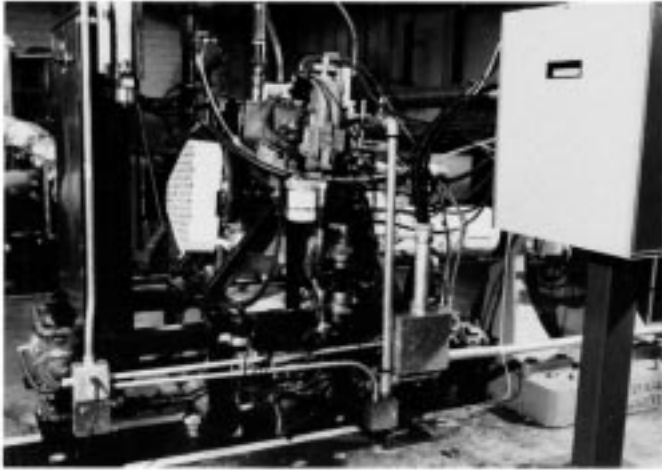

FIG. A3.1 Typical Test Stand, Left Forward View

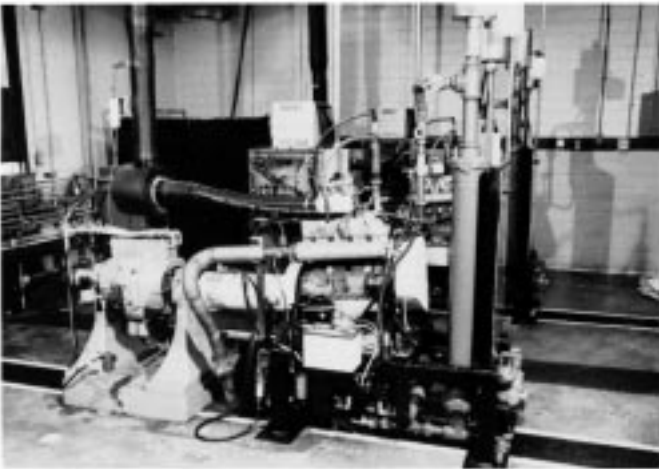

FIG. A3.2 Typical Test Stand, Right Forward View

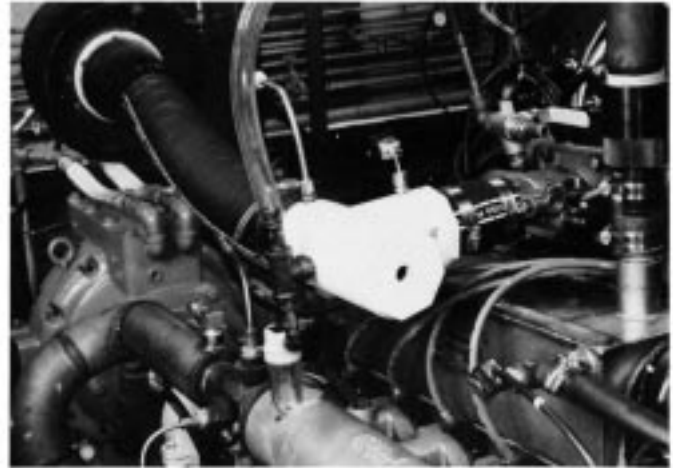

FIG. A3.3 Intake Air Supply System, Air Horn

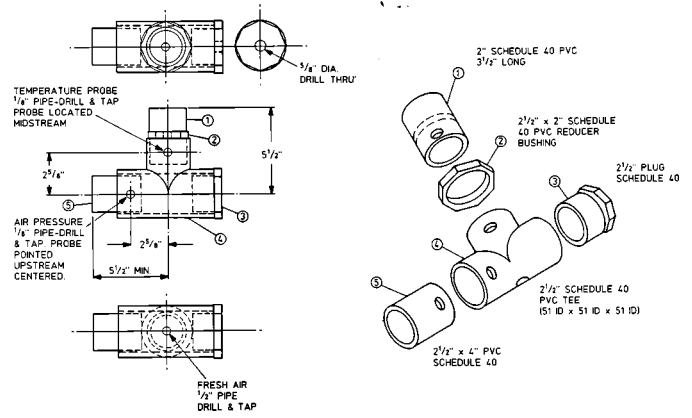
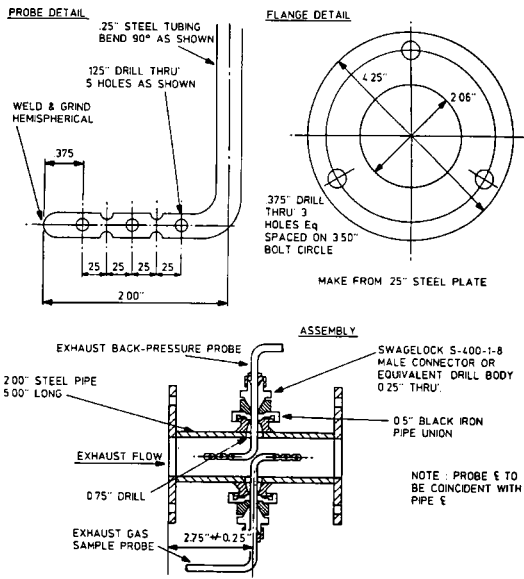
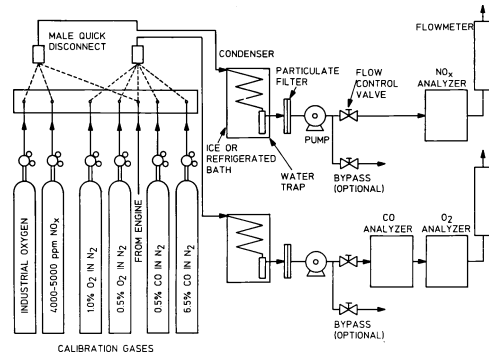

FIG. A3.4 Intake Air Horn



NOTE 1—Bend external tubing segment after assembly parallel with probe axis as shown. This permits visual alignment check during operation.

FIG. A3.5 Exhaust Gas Sample Probe, Exhaust Back Pressure Probe and Flange Assembly



NOTE 1—A typical exhaust gas analysis system is shown in Fig. A3.6. The condenser can use an ice bath or mechanical refrigeration. Ice bath condensers should use a coil fabricated from 0.25-in. (0.64-cm) stainless steel tubing and provide sufficient cooling to condense moisture at a dew point of 34°F (1°C). Mechanical refrigeration should provide control of the bath temperature to 34 ± 2°F (1 ± 1°C). The flow rate of engine exhaust and calibration gases should be identical and within the specifications of the instrumentation. An air-conditioned chamber for instrumentation is required if ambient temperatures are above the maximum recommended for the particular instrumentation used. Stainless steel fittings are preferred throughout the analysis system. Aluminum fittings may cause erroneous NO, and ultimately NO_x readings. Brass fittings should not be used in the analysis system. The porosity of the particulate filter should be between 2 and 10 μm. A diaphragm-type pump is recommended to reduce pump “hang up.” **Warning**—Safety precautions are necessary concerning venting CO, NO, and ozone gases from the analyzer instruments.

NOTE 2—Require Calibration Gases:

- Nominal 5000 ppm NO_x, balance N₂
- Nominal 6.5 % CO, balance N₂
- Nominal 0.5 % CO, balance N₂
- Nominal 1.0 % O₂, balance N₂
- Nominal 0.5 % O₂, balance N₂

Optional Zero Standard Gas:

- N₂ for NO_x, O₂, and CO analyzers

NOTE 3—If the optional zero standard gases are not used to zero the analyzers, the CO calibration gases can be used to zero the O₂ analyzer, the O₂ calibration gases can be used to zero the CO analyzer, and bottled air can be used to zero the NO_x analyzer.

FIG. A3.6 Exhaust Gas Analysis System

- ① THERMOSTAT HOUSING WITH TEMPERATURE SENSOR SEE A3.10 FOR DETAILS
- ② SIGHT GLASS
- ③ VENTURI FLOWMETER MODEL BR12705-16-31 WITH PRESSURE TAPS (SEE NOTE 2)
- ④ FLOW CONTROL VALVE
- ⑤ OPTIONAL TEMPERATURE CONTROL SENSOR
- ⑥ FLUSHING ISOLATION VALVE
- ⑦ FABRICATED COOLANT RESERVOIR
- ⑧ CONSTANT FULL EXPANSION TANK
- ⑨ PRESSURE RADIATOR CAP (MOTORCRAFT R540 P/N D21Y-8100-A)

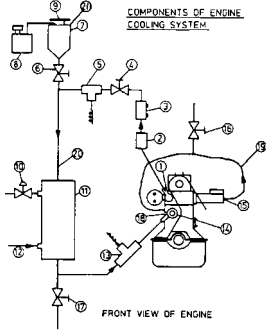

- ⑩ PROCESS WATER CONTROL VALVE (REGULATED BY TEMPERATURE CONTROLLER WITH THREE REMOTE SET POINTS)
- ⑪ HEAT EXCHANGER (ITT STANDARD P/N 5-030-08-048-001 TYPICAL)
- ⑫ PROCESS WATER SUPPLY (SHELL SIDE)
- ⑬ TEE WITH TEMPERATURE SENSOR FOR COOLANT INLET, LOCATED 12-16 INCHES UPSTREAM OF PUMP INLET
- ⑭ ENGINE WATER PUMP
- ⑮ CONNECTION TO INTAKE MANIFOLD (1/2" NPT FITTING 1/2" ID)
- ⑯ AIR BLEED VALVE (1/4" NEEDLE VALVE)
- ⑰ COOLANT SYSTEM DRAIN VALVE
- ⑱ HEATER RETURN HOSE CONNECTION AT PUMP INLET
- ⑲ 1/4" (15.9 mm) I.D. HOSE
- ⑳ ENGINE COOLANT (TUBE SIDE)
- ㉑ PRESSURIZE COOLING SYSTEM TO 15 ± 1 PSIG



FIG. A3.9 Typical Engine Cooling System, Flow Control Valve, Venturi Flowmeter, Expansion Tank, and Sight Glass

NOTE 1—Observe temperature sensor locations in thermostat housing and at water pump inlet.

NOTE 2—See X2.

FIG. A3.7 Typical Engine Cooling System Schematic

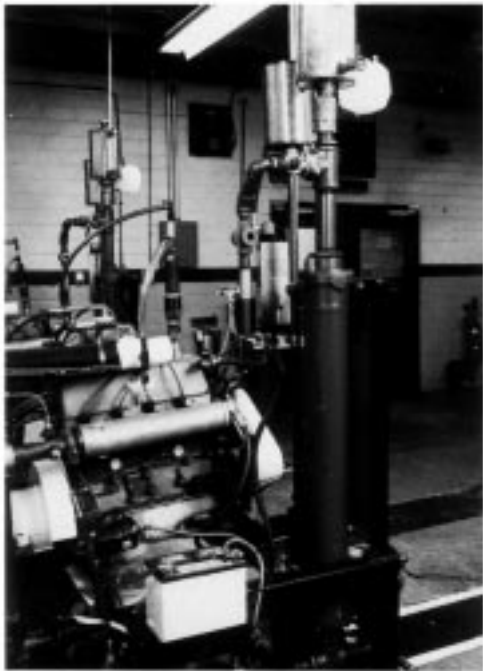
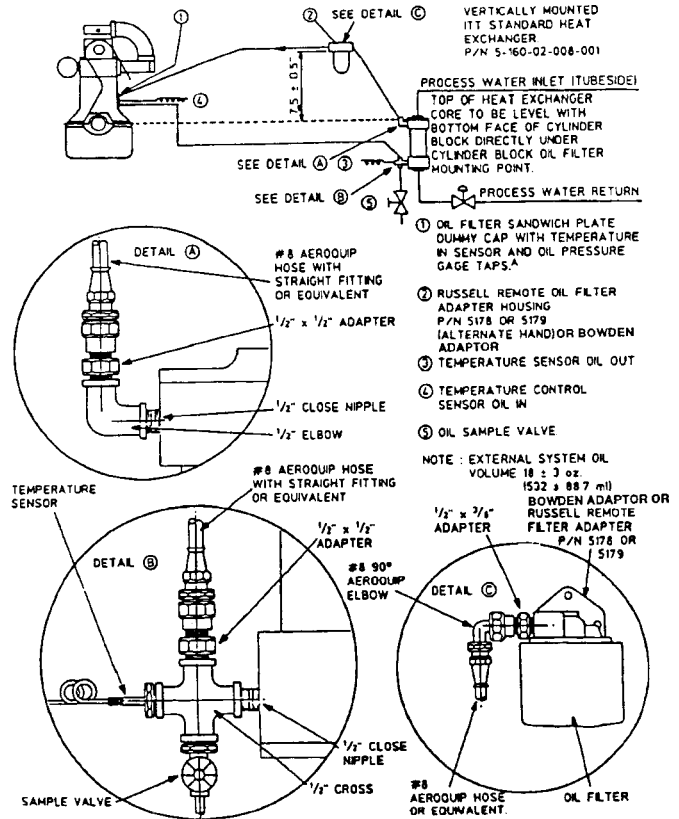

FIG. A3.8 Typical Engine Cooling System, Venturi Flowmeter



A Bowden Adapter BX-570-2 may be used in lieu of Sandwich Plated.

FIG. A3.10 Oil Cooling System Specification

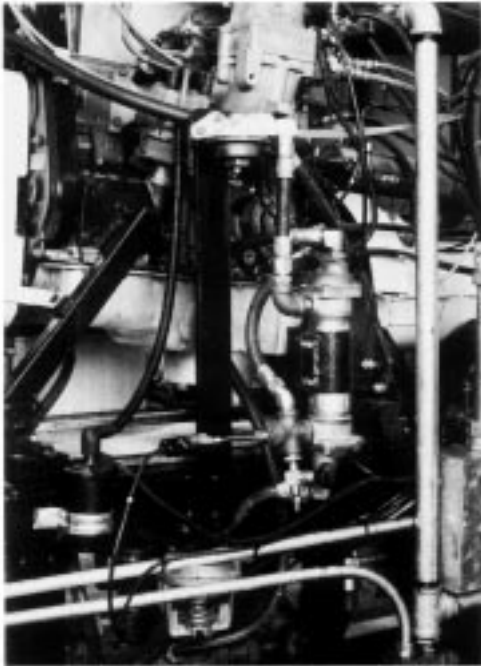

FIG. A3.11 Oil Cooling System Required Heat Exchanger Mounting, Remote Oil Filter Mounting and Typical Hoses and Fittings

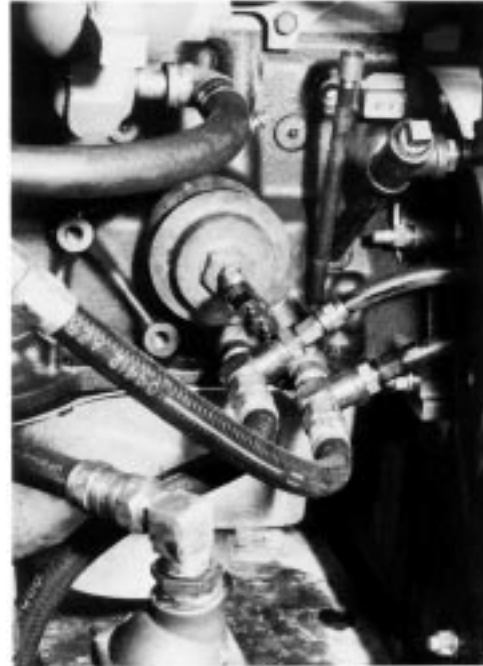

FIG. A3.13 Oil Cooling System, Adapter Housing at Engine with Typical Fittings for Temperature Sensor, Pressure Taps, Dipstick Tube, and Oil Fill Tube

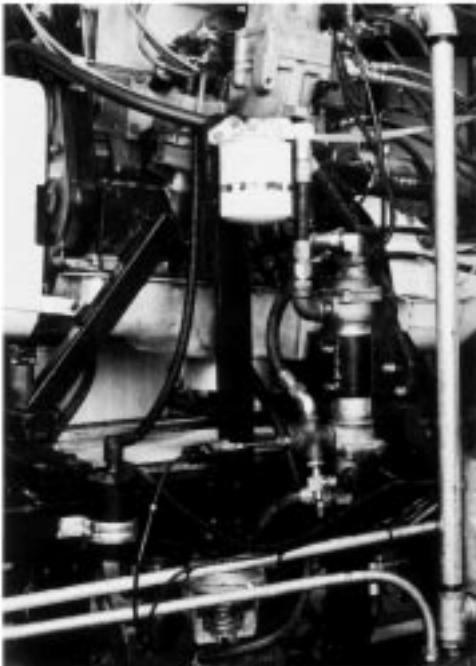

FIG. A3.12 Oil Cooling System Remote Oil Filter Fitted for Break-In

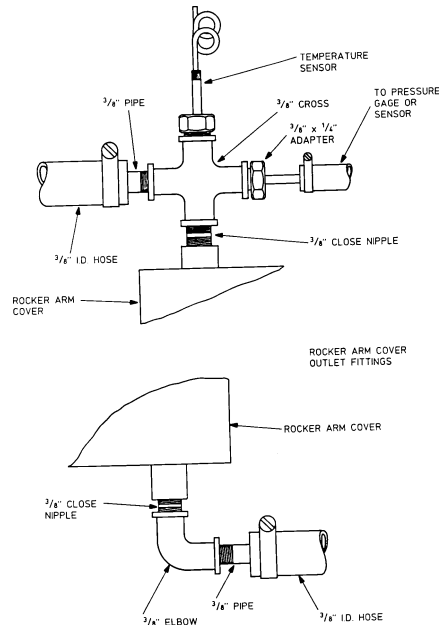

FIG. A3.14 Rocker Arm Cover Required Fittings and Sensor Locations

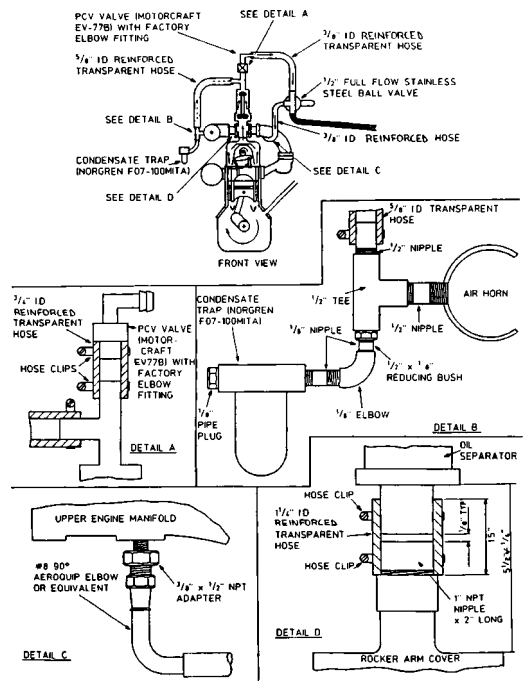
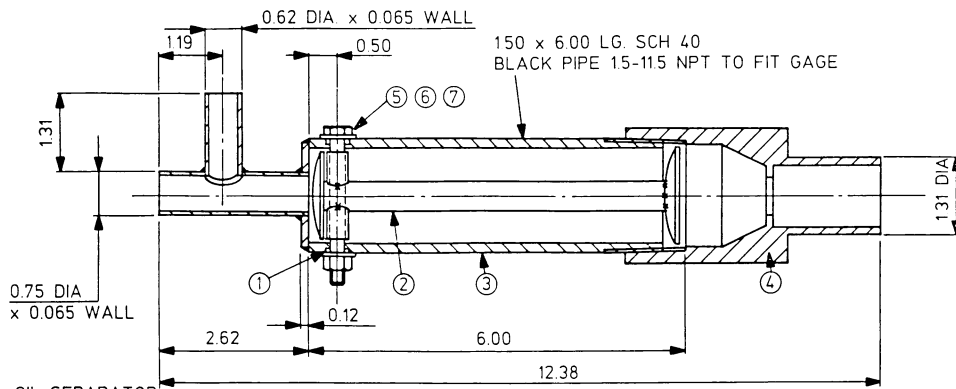

FIG. A3.15 Closed Crankcase Ventilation System, Required Fittings and Parts Configuration

D 5302



OIL SEPARATOR ASSEMBLY

NOTE WELDED CONSTRUCTION. ALL WELDS TO BE LIQUID TIGHT. BREAK SHARP EDGES.

BILL OF MATERIAL				
ITEM	REQD	DESCRIPTION	PART No.	MANU.
1	2	O-RING VITON	2-D10	PARKER
2	1	INNER BAFFLE		
3	1	OUTER SHELL		
4	1	ADAPTER		
5	1	0.25 20 x 2.50 LG. HEX. HD. SCREW		
6	2	0.25 FLAT WASHER		
7	1	0.25 20 HEX. NUT		

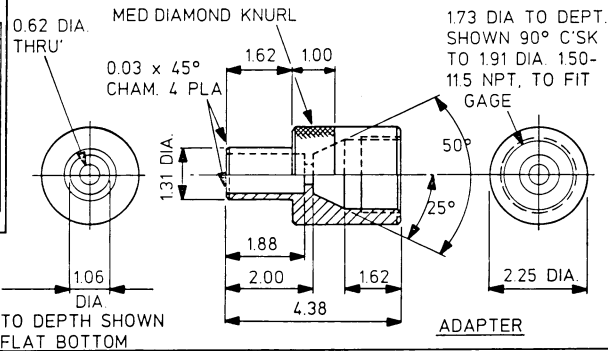

INNER BAFFLE

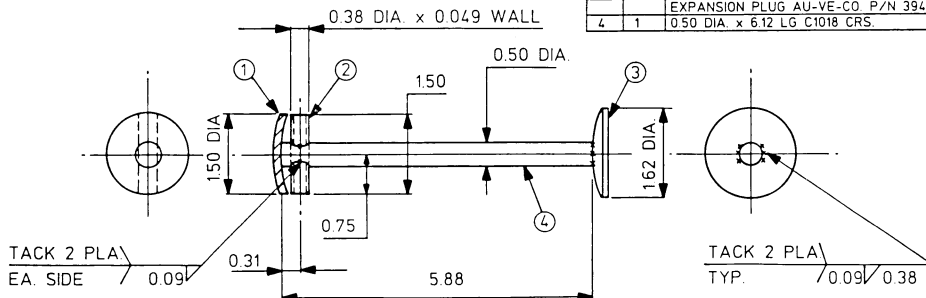

ITEM	REQD	DESCRIPTION
1	1	150 DIA. ZINC PLATED CONCAVE EXPANSION PLUG AU-VE-CO P/N 3948
2	1	0.38 O.D. x 0.049 WALL x 175 LG. STEEL TUBING
3	1	162 DIA. ZINC PLATED CONCAVE EXPANSION PLUG AU-VE-CO P/N 3949
4	1	0.50 DIA. x 6.12 LG C1018 CRS.

FIG. A3.16 Fabricated Oil Separator for Engine Ventilation System

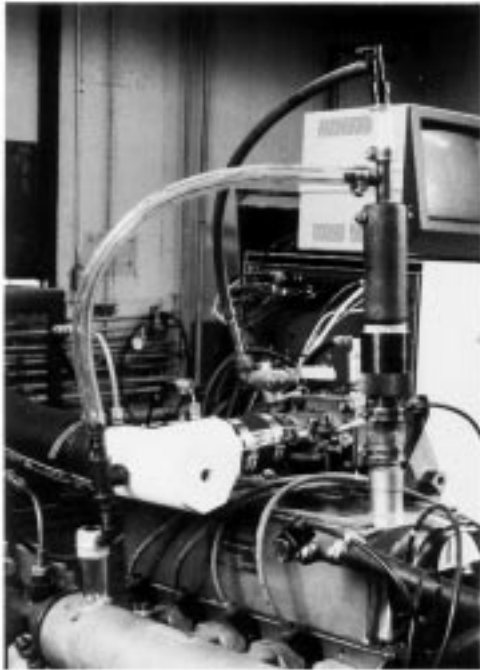

FIG. A3.17 Engine Ventilation System

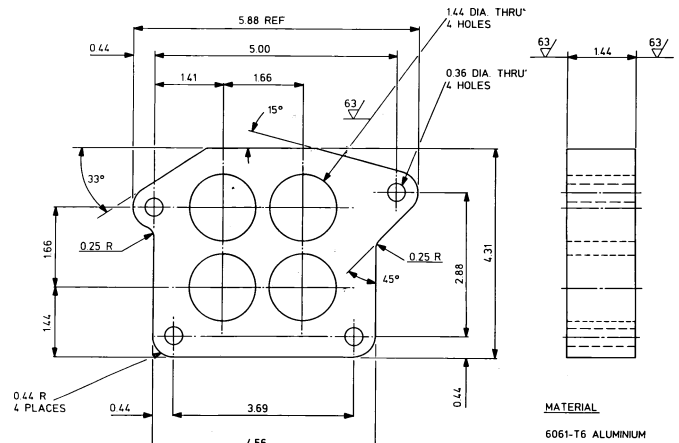

FIG. A3.20 Intake Manifold Spacer

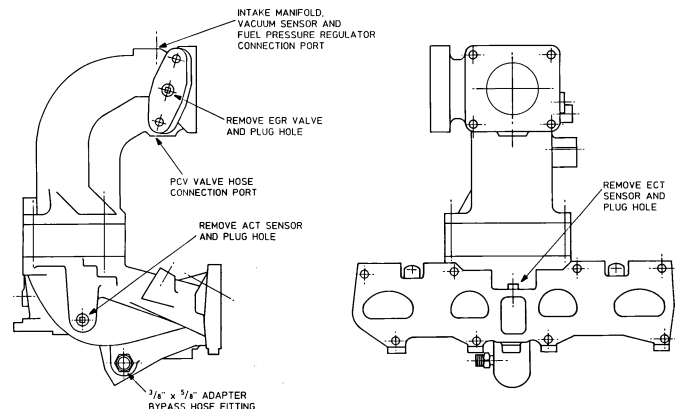

FIG. A3.21 Intake Manifold Modifications

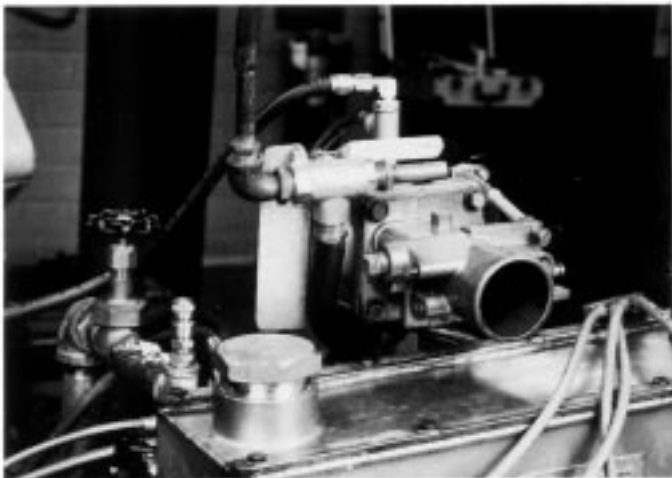

FIG. A3.18 Engine Ventilation System, Three-Way Valve

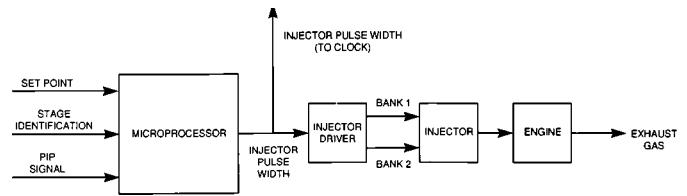

FIG. A3.22 Schematic Drawing of Open-Loop Fuel Management System

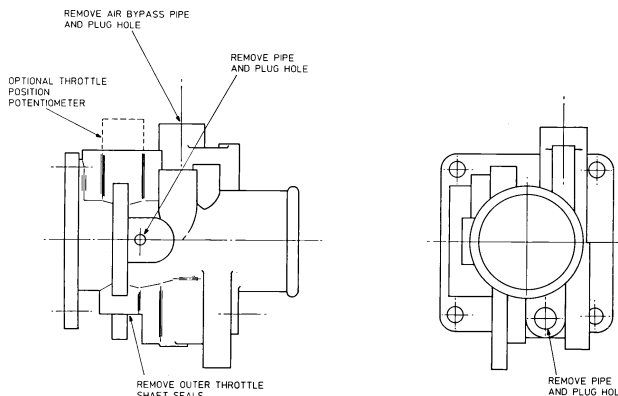

FIG. A3.19 Throttle Body Modifications

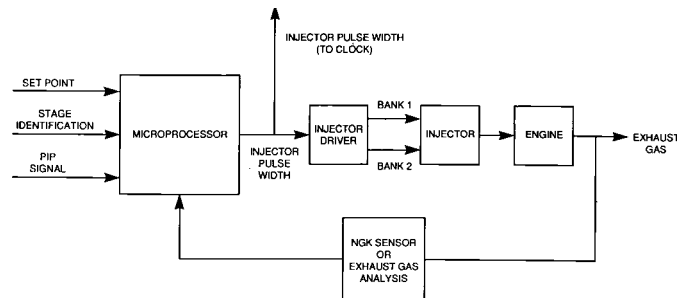

FIG. A3.23 Schematic Drawing of Closed-Loop Fuel Management System

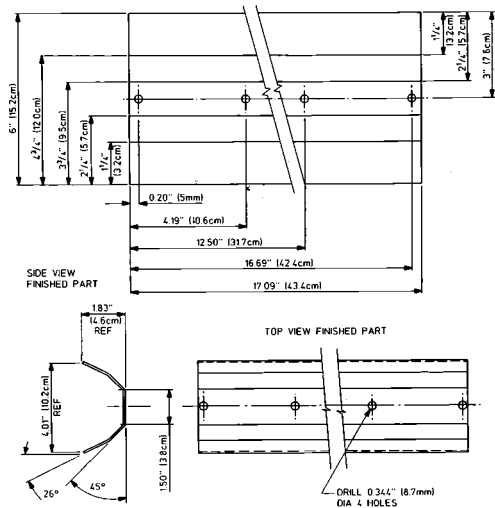
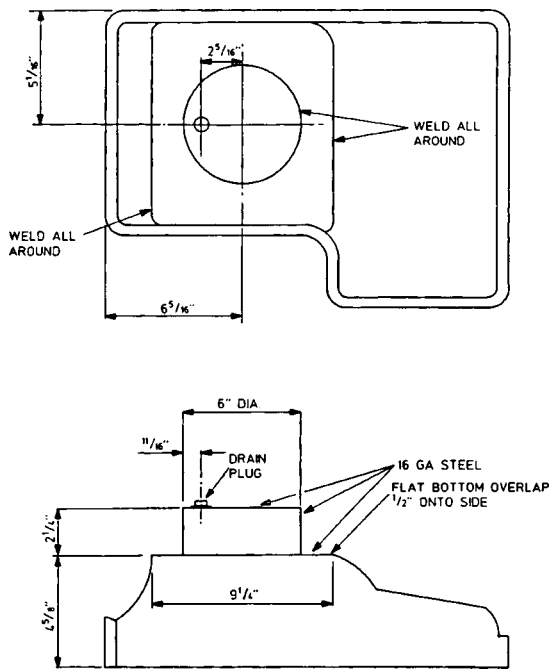
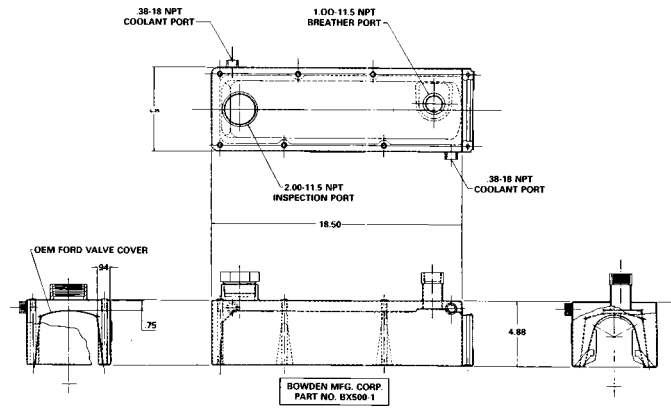

FIG. A3.24 Camshaft Baffle Fabrication



NOTE 1—Tin plate all over by electroplating to a thickness of 0.0005 in. (0.013 mm).

FIG. A3.25 Modified Engine Oil Pan



NOTE 1—Dimensions: inches (outside of parentheses)—millimetres (inside of parentheses).

FIG. A3.26 Heated and Cooled Rocker Cover Modification

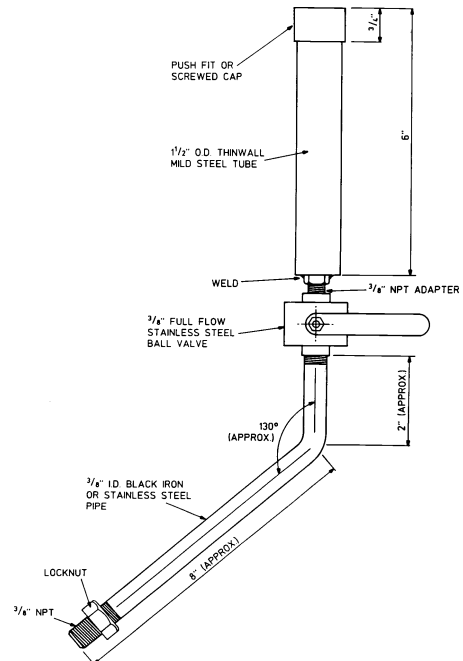

FIG. A3.27 Typical Crankcase Oil Fill Tube and Cap

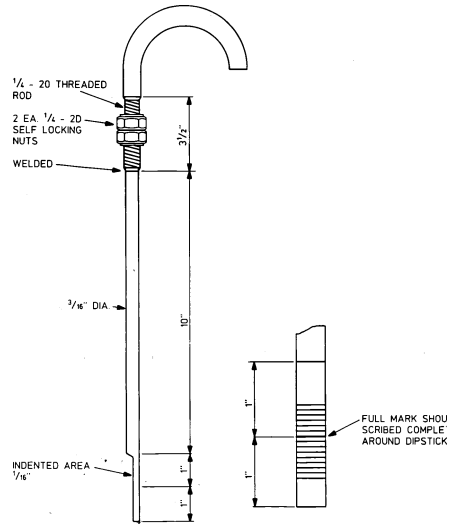

FIG. A3.28 Typical Adjustable Dipstick Fabrication

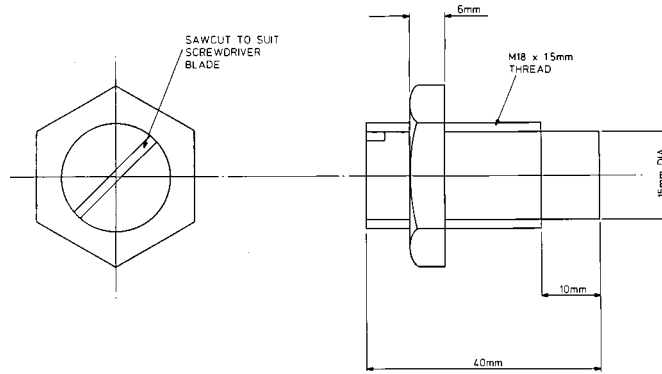
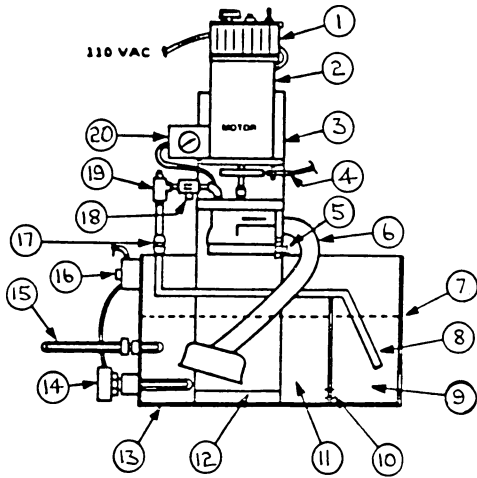

FIG. A3.29 Oil Pressure Relief Valve Adjuster



- ① MOTOR CONTROLLER WITH SPEED ADJUSTMENT
- ② PERMANENT MAGNET VARIABLE SPEED DC MOTOR (SEE NOTE 1).
- ③ MOTOR AND PUMP MOUNTING PEDESTAL.
- ④ 60 TOOTH SPEED PICK-UP ASSEMBLY.
- ⑤ RELIEF VALVE ADJUSTER.
- ⑥ OIL PICK-UP TUBE MOUNTED TO THE OIL PUMP.
- ⑦ OIL LEVEL.
- ⑧ 1/2 in. (12.7 mm) ID DISCHARGE TUBE.
- ⑨ SUMP DISCHARGE COMPARTMENT.
- ⑩ OIL RETURN HOLE 1 in. (25.4 mm) DIA. 2 PLACES.
- ⑪ PICK-UP COMPARTMENT OF SUMP ASSEMBLY.
- ⑫ BASE OF MOTOR AND PUMP MOUNTING PEDESTAL.
- ⑬ SECTIONED VIEW OF SUMP ASSEMBLY.
- ⑭ 110v IMMERSION HEATER
- ⑮ THERMOMETER
- ⑯ TEMPERATURE CONTROL FOR HEATER.
- ⑰ 1/2" PIPE TO 1/2" TUBING UNION.
- ⑱ TURBINE FLOW METER (OPTIONAL) (SEE NOTE 2).
- ⑲ X" TEE FITTING WITH 0.180 in. ORIFICE THREADED IN LOWER BRANCH, WITH PLUG IN UPPER BRANCH (SEE NOTE 3)
- ⑳ OIL PRESSURE GAGE 1% ACCURACY, 1 psi RESOLUTION (6.9 kPa).

NOTE 1 - DAYTON DC MOTOR MODEL 2Z846 IS SUGGESTED (1/2 hp @ 2500 rpm, rpm 0-2500, FRAME 56/56C, DAYTON ELECTRIC MFG. CO. CHICAGO, ILL. 60648)

NOTE 2 - INVALCO MODEL W3/0750 IS SUGGESTED, 1-13 ppm, ss, C-E INVALCO, COMBUSTION ENGINEERING INC., P. O. BOX 556, TULSA, OKLAHOMA, 74101.

NOTE 3 - ORIFICE IS 0.180 ± 0.0005 in. (4.572 ± 0.013mm) dia., 1/4 in. (6.4 mm) DEEP, MACHINED FROM BRASS.

NOTE 4 - TO ELIMINATE AERATION THE OIL IS RETURNED TO A SEPARATE COMPARTMENT VIA THE 1/2 in. ID TUBING. THE OIL RETURNS TO THE PICK-UP COMPARTMENT VIA THE HOLES INDICATED. A TRANSPARENT SECTION IN THE DISCHARGE TUBE IS HELPFUL IN IDENTIFYING EXCESSIVE AERATION.

NOTE 5 - OPERATING CONDITIONS: SPEED 1250 ± 10 rpm, TEMPERATURE 125 ± 5°F (51.7 ± 2.8°C), FLOW RATE 6.6 ± 0.1 ppm (0.416 ± 0.006 dm³/s AT 60 ± 1 psi (413.7 ± 6.9 kPa).

NOTE 6 - PURCHASE AVAILABILITY: SEE X 2-5, X 2-14

Schedule 40 A. S. A. Pipe Dimensions

NPT nominal	OD		ID	
	in	mm	in	mm
1/4	.640	13.72	.364	9.24
1/2	.840	21.34	.622	15.80

FIG. A3.30 Oil Pump Calibration Apparatus

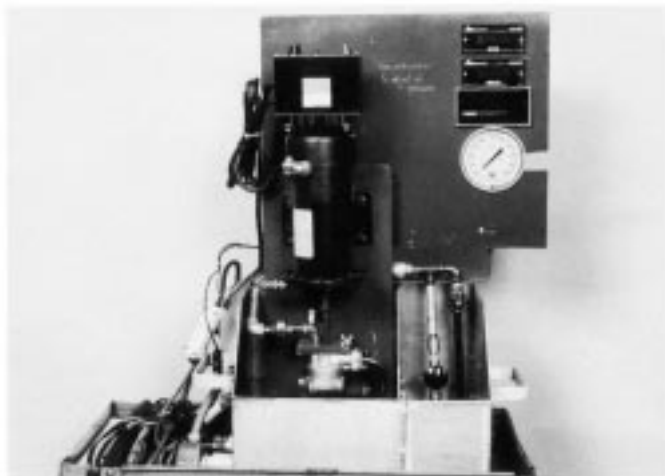
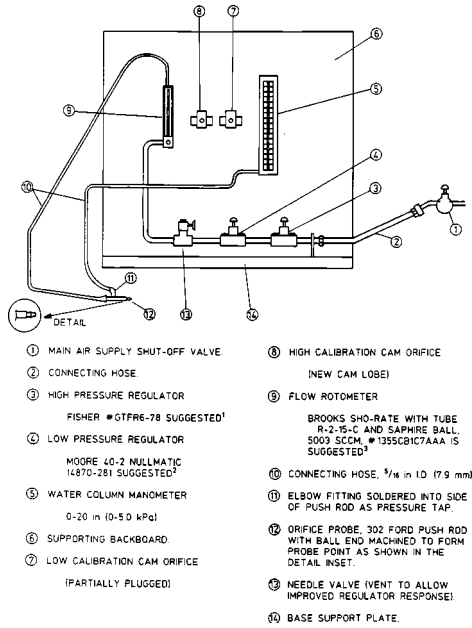

FIG. A3.31 Oil Pump Calibration Apparatus



NOTE 1—Available from Fisher Controls, Marshalltown, Iowa 50158.
 NOTE 2—Available from Moore Products Co., Springhouse, PA 19477.
 NOTE 3—Available from Brooks Instrument, Div. Emerson Electric
 Co., Hatfield, PA 19440.

FIG. A3.32 Camshaft Lobe Flow Rating Apparatus

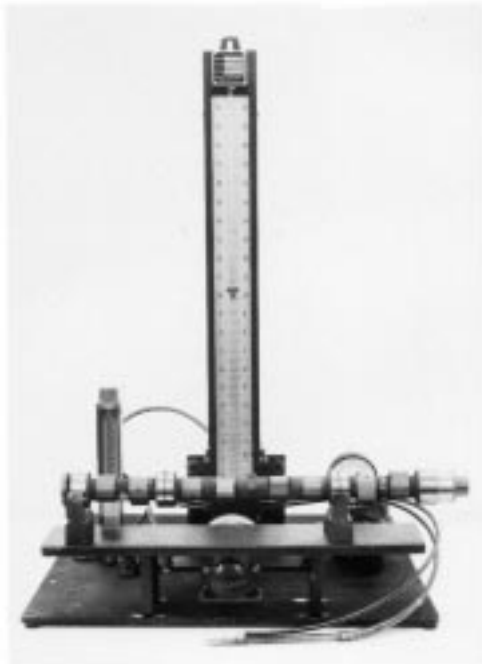

FIG. A3.33 Typical Camshaft Lobe Flow Rating Apparatus

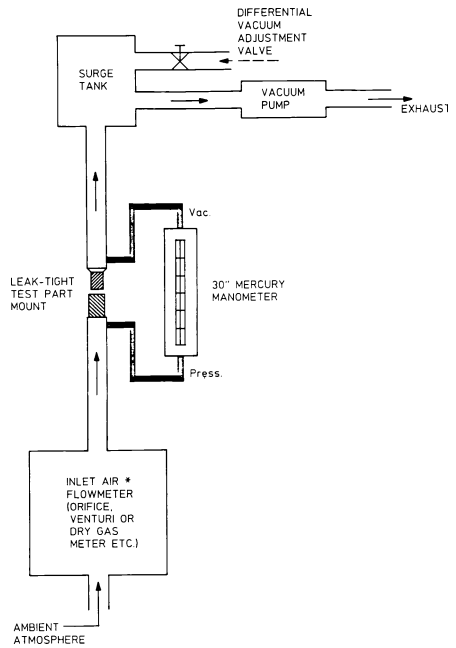

FIG. A3.34 PCV Valve Flow Test Apparatus

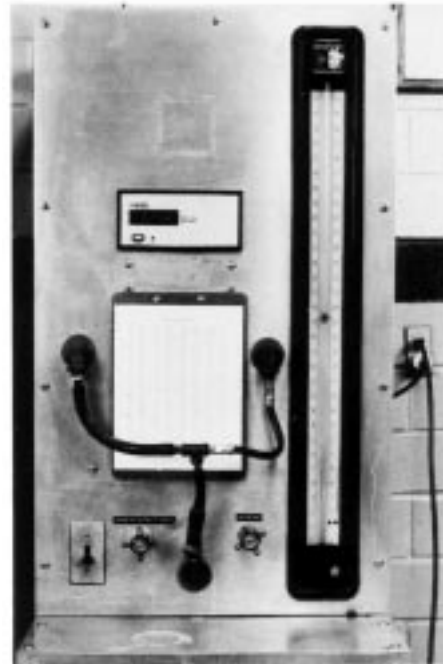

FIG. A3.35 Typical PCV Valve Flow Test Stand

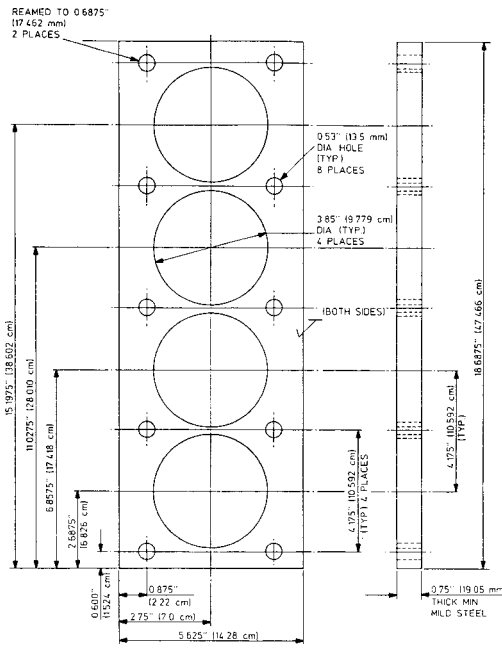
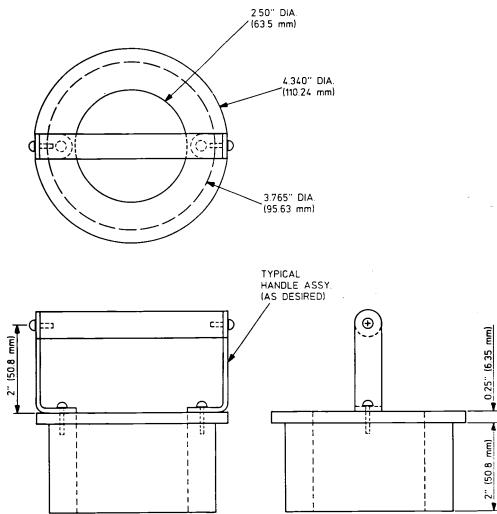

FIG. A3.36 Cylinder Block Stress Plate



TOLERANCES: ± 0.005" (0.13 mm)

MATERIAL: ALUMINUM

FIG. A3.37 Piston Ring Positioner

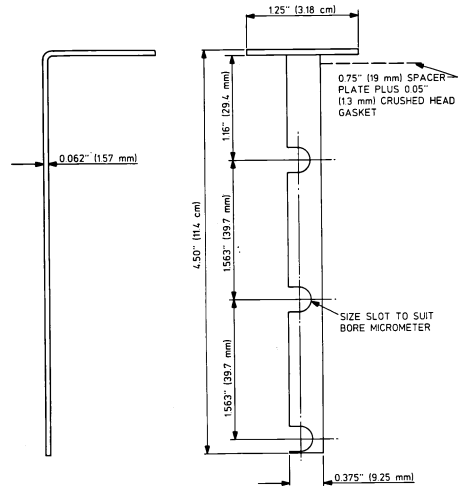

MATERIAL: BRASS OR STEEL SHEET

* DIMENSION ASSUMES PRE-STRESS PLATE THICKNESS OF 0.75" (19.05 mm) AND USE OF CRUSHED GASKET BENEATH PLATE

FIG. A3.38 Positioning Ladder for Bore Micrometer

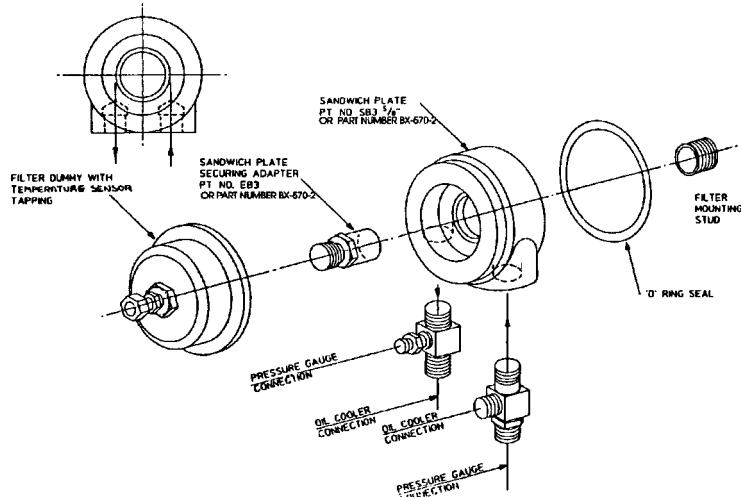

FIG. A3.39 Modified Oil Filter Sandwich Plate With Dummy Filter

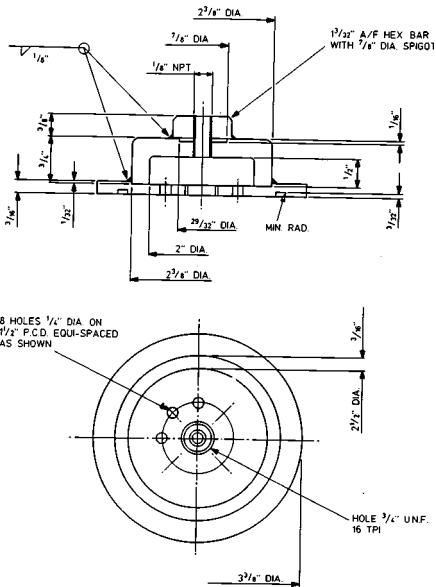

FIG. A3.40 Dummy Filter

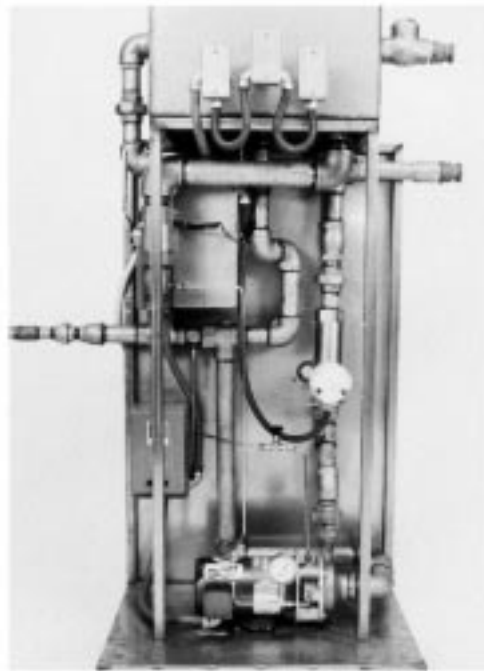

FIG. A3.41 Engine Cooling System Flushing Cart

Tool Number	Description	Tool Number	Description
T74P-6000LA	2.3 litre Service Tool Kit	T74P-6375-A	Flywheel Holding Tool
T74P-6015-A	Engine Plug Replacer	T74P-6565-A	Valve Spring Compressor
T74P-6019-B	Front Cover Alignment Tool	T73P-6571-A	Valve Seal Installer
T68P-6135-A	Piston Pin Remover/Replacer	T79P-6634-A	Pressure Diagnostic Gauge
T74P-6136-A	Crankshaft Timing Gear Remover/Adapter	T74P-6700-B	Front Cover Seal Remover
T74P-6150-A	Camshaft and Aux. Shaft Seal Replacer	T82L-6701-A	Crankshaft Seal Installer
T71P-6250-A	Camshaft Bearing Replacer	D79L-6731-B	Oil Filter Wrench
T74P-6254-A	Camshaft Belt Tension Adjusting Tool	T71P-7137-C	Pilot Bearing Replacer
T74P-6256-B	Camshaft and Aux. Shaft Glide Hammer Sprocket Tool	T71P-7137-H	Clutch Aligner
T59L-100-B	Slide Hammer	T77L-9533-B	Jet Plug Remover/Small
		T58L-101-A	Puller Attachment
		T74P-6306-A	Crankshaft Timing Gear Tool
		T74P-6312-A	Crankshaft Damper Remover

FIG. A3.42 Special Service Tools for the Ford 2.3-L Engine

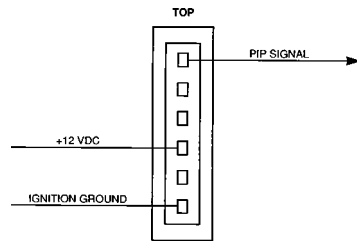

FIG. A3.43 Schematic Diagram of Ignition Module Connector

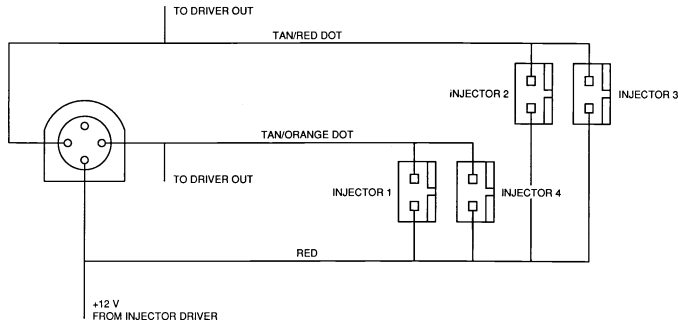

FIG. A3.44 Schematic Diagram of Injector Wiring Harness

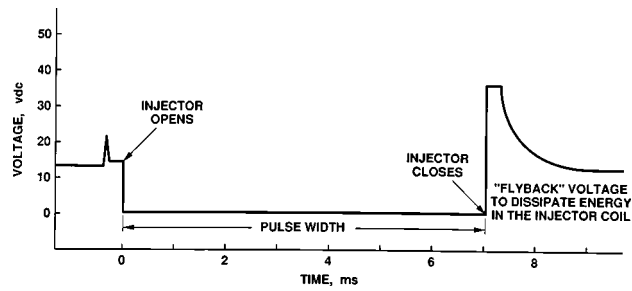

FIG. A3.45 Typical Ford EEC-IV Pulse Width

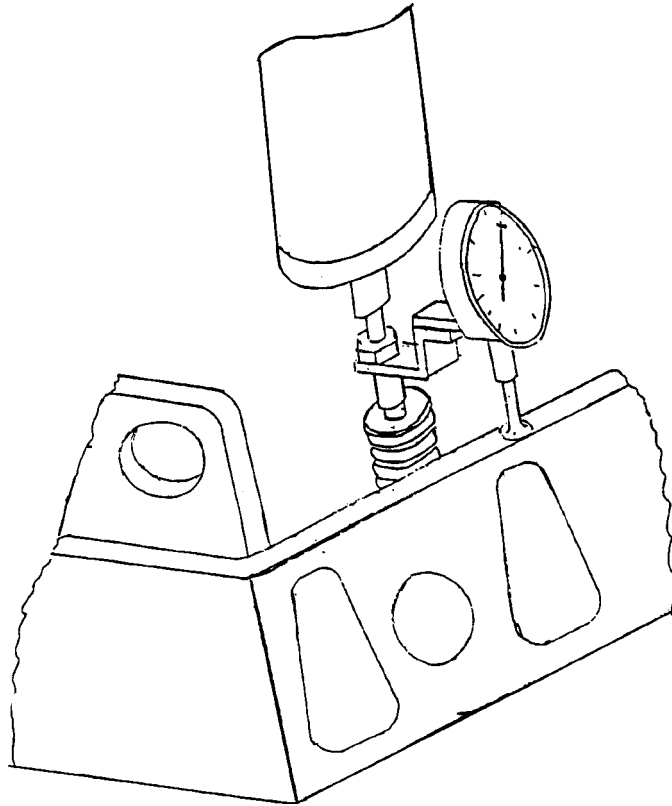

FIG. A3.46 Locating the Dial Indicator for Cylinder Head Calibration

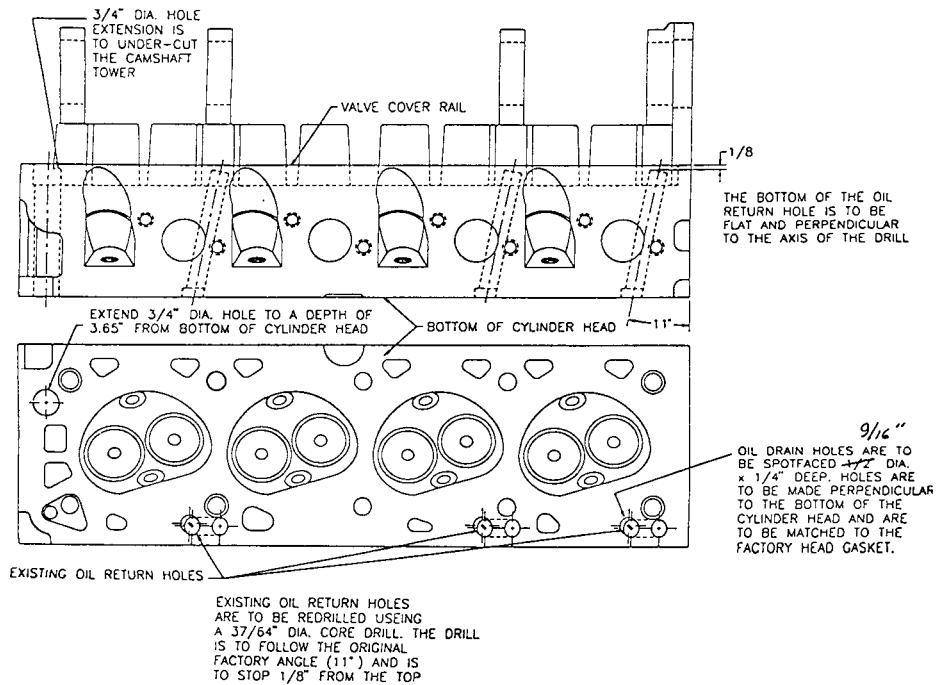

FIG. A3.47 Cylinder Head Modifications

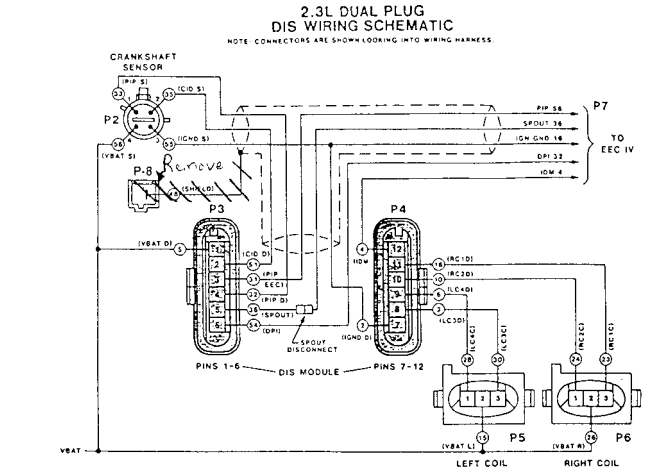

FIG. A3.48 Modifications to Distributorless Ignition System Wiring Harness

A4. ENGINE PART NUMBER LISTING

A4.1 See Table A4.1 and Table A4.2.

TABLE A4.1 Continued

TABLE A4.1 1987 ASTM Sequence VE Engine Kit			TABLE A4.1 Continued		
Number Per Kit	Part Name	Engineering Part Number	Number Per Kit	Part Name	Engineering Part Number
1	Short Block Assembly	F17E-6009-BA	8	Dowel-Head-Block	D42E-6A008-A2A
1	Bare Block Assembly	E97E-6010-BA	2	Piston Kit 0.5 mm oversize	E9JL-6A108-AB
4	Gasket—Front Cover	E89E-6020-AB	2	Piston Kit 0.2 mm oversize	E9JL-6A108-BB
4	Cylinder Head Assembly	F27E-6049-A11A	2	Plate-Cam/Aux Shaft	D42E-6A222-A2B
8	Gasket—Cylinder Head	E89E-6059-D5A	20	Bearing—Main Lower	E97E-6A338-BA
1	Cover Front	E89E-6059-AC	48	Seal Intake Valve	E7ZE-6A517-AA
2	Kit Piston Ring 0.15 mm oversize	E9JL-6148-AB	1	Shaft and Hsg. Assembly-Oil Pump Drive	E97E-6C642-AA
2	Kit Piston Ring 0.45 mm oversize	E9JL-6148-BB	1	Guide-Timing Belt-Cam	D42E-6B260-AA
32	Connecting Rod Bearing	D42E-6211-AA	4	PCV Valve (EV-17B) and Elbow Assembly	D8DE-6A666-BA
4	Camshaft Assembly	E59E-6251-DA	1	Guide-Timing Belt-Crank	D42E-6C312-AB
4	Belt Timing	E5RE-6268-A2A	32	Tappet	EOEE-6C501-AA
1	Washer—Camshaft Sprocket	D42E-6278-AA	1	Cover-Timing Belt Inner	F07E-6E006-AA
28	Main Bearings	E97E-6333-AA	1	Cover-Timing Belt Outer	F27E-5E004-AA
1	Crankshaft	E89E-6303-AB	1	Shaft Assembly Auxiliary	E7TE-6K230-AA
12	Main Bearings—Blue	E97E-6333-BA	1	Bolt-Tensioner Assembly	E97E-6K282-BA
4	Upper Thrust Bearing	E97E-6333-BA	1	Spring-Tensioner Assembly	D52-6L273-AA
20	Valve—Exhaust	E43E-6505-B2A	4	Gasket-Up. Man.-Throttle	E59E-9E936-AA
20	Valve—Intake	E79E-6507-A2A	4	Fuel Injector	F03E-9F593-A2B
8	Spring—Valve	E7JL-6513-AA	8	Seal-Throttle Body Insert	E57E-9F791-AA
8	Retainer—Valve Spring	E43E-6514-AC	8	Gasket-Upper Manifold-Lower Manifold	E89E-9H486-AC
32	Key—Valve Spring Retainer	D0AE-6518-B3	1	Seal, Oil Pump Shaft	E89E-12A118-AA
32	Rocker Arm	D8EE-6564-A1A	4	Plug-Cup 2 ⁵ / ₆₄ in. (mm)	376047-S100
8	Gasket—Rocker Arm Cover	F0ZE-6584-ACA	16	Plug-Cup 1 ¹ / ₂ in. (mm)	376053-S36
4	Pump Assembly—Oil	E59E-6621-BC	1	Plug-Cup 3/4 Oil Pump Shaft	376099-S
4	Pickup Tube Screen and Cover	E59E-6622-BA	1	Washer-Auxiliary Sprocket	385803-S
4	Gasket—Oil Pump Tube	E8ZE-6625-AA	1	Dowel-Auxiliary Shaft	385803-S
16	Seal—Crankshaft Front	E6ZE-6700-A2A	8	Plug-Oil Gallery-Head	87837-S100
4	Seal—Crankshaft Rear	E4ZE-6701-A2A	16	Plug-Oil Gallery-Block	87837-S100
8	Gasket—Oil Pan	E6ZE-6710-A6B	2	S and W-Fuel Rail to Intake Manifold	N602734-S100
4	Filter Oil	E9TE-6714-A1A	1	Nut-Oil Screen to Bearing Cap	N620484-S2
4	Gasket—Oil Drain Plug	E8DE-6734-AA	1	Bolt-Auxiliary Shaft Sprocket	N600313-S2
2	Insert—Oil Filter	E85E-6890-AA	1	Bolt-Camshaft Sprocket	N600414-S100
4	Gasket—Thermostat Housing	E87E-8255-AA	4	S and W Front/Auxiliary Cover-Block	N602529-S2
4	Gasket—Low Man. Head	E89E-9439-A5C	4	S and W Auxshaft Cover to Block	N800110-S
4	Gasket—Exhaust Manifold	D9EE-9448-BA	8	S and W-Exhaust Manifold to Head	N802884-S100
1	Clamp—Distributor	D9ZE-12270-AA	1	Key, C/S, Hub and Sprocket	N806700-S
1	Ignition Wires—R.H.	F17E-12280-BA	2	S and W-Thermostat Housing to Head	N800025-S
1	Ignition Wires—L.H.	F17E-12280-AA	8	S and W-Intake Manifold to Head	N805731-S100
40	Spark Plugs—AWSF32F	E7DE-12405-BA	2	S and W-Oil Pump-Block	N800032-S
1	Washer, Crankshaft, Damper	D8EE-6378-AA	2	Dowel-Oil Pump-Block	N800059-S
1	Plug, Oil Pan Drain	E9DE-6730-AA	4	S and W-Auxiliary Shaft Plate	N604465-S
			2	S and W-Pickup Tube to Oil Pump	N602550-S
			1	Bolt-Distributor Clamp	N800088-S2
			1	Screw-Timing Belt Cover	N800167-S2

TABLE A4.1 Continued

Number Per Kit	Part Name	Engineering Part Number
5	S and W-Inner Timing Belt Cover to Front Cover	N621906-S2
40	Bolt-Heat to Block	N807013-S
16	S and W-Oil Pan to Block	N806378-S141
2	Stud-Tensioner to Inner Timing Belt Cover	N804964-S100
4	Bolt-Oil Pan to Front Cover	N806379-S141
1	Stud-Inner Timing Belt Cover to Front Cover	N805595-S2

TABLE A4.2 1992 ASTM Stand Set Up Kit

Number Per Kit	Part Name	Engineering Part Number
2	Sprocket—Camshaft/Auxshaft	D6EE-6256-A1A
1	Sprocket—Crankshaft	E87E-6306-AA
1	Conn—W/O	F1ZE-8594-AA
1	Intake Manifold, Upper	E79E-9425-BA
2	Cover, Auxiliary Shaft	D42E-6E007-AB
1	Throttle Body	E77E-9E926-AC
1	Intake Manifold, Lower	E7ZE-9K461-BA
1	Manifold Assembly, Fuel Injector	F12E-9S441-AA
1	Tensioner Assembly	D42E-6K254-AD
1	Flywheel, Manual Transmission	E27R-6375-AB

A5. OPERATIONAL DATA LOG SHEETS

A5.1 See Figs. A5.1-A5.3.

**SEQUENCE VE
OIL SAMPLING, ADDITION, AND LEVELING RECORD**

Test Number: _____ Laboratory Oil Code: _____
Client Oil Code: _____

Cycle	3	6	9	12	15	18	21	24	27	30	33	36	39	42	45	48	51	54	57	60	63	66	69	72	
Test Hour, hr	12	24	36	48	60	72	84	96	108	120	132	144	156	168	180	192	204	216	228	240	252	264	276	288	
Specific Action Time, hr:min	11:25	23:25	35:24	47:25	59:25	71:25	83:25	95:25	107:25	119:25	131:25	143:25	155:25	167:25	179:25	191:25	203:25	215:25	227:25	239:25	251:25	263:25	275:25	287:25	
1. Remove a 5-oz purge sample.	<input type="checkbox"/>	<input checked="" type="checkbox"/>	<input type="checkbox"/>	<input checked="" type="checkbox"/>	<input type="checkbox"/>	<input checked="" type="checkbox"/>	<input type="checkbox"/>	<input checked="" type="checkbox"/>	<input type="checkbox"/>	<input checked="" type="checkbox"/>	<input type="checkbox"/>	<input checked="" type="checkbox"/>	<input type="checkbox"/>	<input checked="" type="checkbox"/>	<input type="checkbox"/>	<input checked="" type="checkbox"/>	<input type="checkbox"/>	<input checked="" type="checkbox"/>	<input type="checkbox"/>	<input checked="" type="checkbox"/>	<input type="checkbox"/>	<input checked="" type="checkbox"/>	<input type="checkbox"/>	<input checked="" type="checkbox"/>	
2. Replace the 5-oz purge sample.	<input type="checkbox"/>	<input checked="" type="checkbox"/>	<input type="checkbox"/>	<input checked="" type="checkbox"/>	<input type="checkbox"/>	<input checked="" type="checkbox"/>	<input type="checkbox"/>	<input checked="" type="checkbox"/>	<input type="checkbox"/>	<input checked="" type="checkbox"/>	<input type="checkbox"/>	<input checked="" type="checkbox"/>	<input type="checkbox"/>	<input checked="" type="checkbox"/>	<input type="checkbox"/>	<input checked="" type="checkbox"/>	<input type="checkbox"/>	<input checked="" type="checkbox"/>	<input type="checkbox"/>	<input checked="" type="checkbox"/>	<input type="checkbox"/>	<input checked="" type="checkbox"/>	<input type="checkbox"/>	<input checked="" type="checkbox"/>	
3. Remove a 2-oz analysis sample.	<input type="checkbox"/>	<input checked="" type="checkbox"/>	<input type="checkbox"/>	<input checked="" type="checkbox"/>	<input type="checkbox"/>	<input checked="" type="checkbox"/>	<input type="checkbox"/>	<input checked="" type="checkbox"/>	<input type="checkbox"/>	<input checked="" type="checkbox"/>	<input type="checkbox"/>	<input checked="" type="checkbox"/>	<input type="checkbox"/>	<input checked="" type="checkbox"/>	<input type="checkbox"/>	<input checked="" type="checkbox"/>	<input type="checkbox"/>	<input checked="" type="checkbox"/>	<input type="checkbox"/>	<input checked="" type="checkbox"/>	<input type="checkbox"/>	<input checked="" type="checkbox"/>	<input type="checkbox"/>	<input checked="" type="checkbox"/>	
4. Add 5 oz of new oil (except at 288 hours).	<input type="checkbox"/>	<input checked="" type="checkbox"/>	<input type="checkbox"/>	<input checked="" type="checkbox"/>	<input type="checkbox"/>	<input checked="" type="checkbox"/>	<input type="checkbox"/>	<input checked="" type="checkbox"/>	<input type="checkbox"/>	<input checked="" type="checkbox"/>	<input type="checkbox"/>	<input checked="" type="checkbox"/>	<input type="checkbox"/>	<input checked="" type="checkbox"/>	<input type="checkbox"/>	<input checked="" type="checkbox"/>	<input type="checkbox"/>	<input checked="" type="checkbox"/>	<input type="checkbox"/>	<input checked="" type="checkbox"/>	<input type="checkbox"/>	<input checked="" type="checkbox"/>	<input type="checkbox"/>	<input checked="" type="checkbox"/>	
5. Shut down the engine.	<input checked="" type="checkbox"/>	<input type="checkbox"/>	<input checked="" type="checkbox"/>	<input type="checkbox"/>	<input checked="" type="checkbox"/>	<input type="checkbox"/>	<input checked="" type="checkbox"/>	<input type="checkbox"/>	<input checked="" type="checkbox"/>	<input type="checkbox"/>	<input checked="" type="checkbox"/>	<input type="checkbox"/>	<input checked="" type="checkbox"/>	<input type="checkbox"/>	<input checked="" type="checkbox"/>	<input type="checkbox"/>	<input checked="" type="checkbox"/>	<input type="checkbox"/>	<input checked="" type="checkbox"/>	<input type="checkbox"/>	<input checked="" type="checkbox"/>	<input type="checkbox"/>	<input checked="" type="checkbox"/>	<input type="checkbox"/>	
6. Allow 20 min. to elapse and remove the dipstick.	<input checked="" type="checkbox"/>	<input type="checkbox"/>	<input checked="" type="checkbox"/>	<input type="checkbox"/>	<input checked="" type="checkbox"/>	<input type="checkbox"/>	<input checked="" type="checkbox"/>	<input type="checkbox"/>	<input checked="" type="checkbox"/>	<input type="checkbox"/>	<input checked="" type="checkbox"/>	<input type="checkbox"/>	<input checked="" type="checkbox"/>	<input type="checkbox"/>	<input checked="" type="checkbox"/>	<input type="checkbox"/>	<input checked="" type="checkbox"/>	<input type="checkbox"/>	<input checked="" type="checkbox"/>	<input type="checkbox"/>	<input checked="" type="checkbox"/>	<input type="checkbox"/>	<input checked="" type="checkbox"/>	<input type="checkbox"/>	
7. DIPSTICK OIL LEVEL Record the dipstick oil level in oz. "O" indicates full, while "H" indicates high and "L" indicates low. "H" and "L" must be preceded by the number of oz high or low.	<input type="checkbox"/>	<input type="checkbox"/>	<input type="checkbox"/>	<input type="checkbox"/>	<input type="checkbox"/>	<input type="checkbox"/>	<input type="checkbox"/>	<input type="checkbox"/>	<input type="checkbox"/>	<input type="checkbox"/>	<input type="checkbox"/>	<input type="checkbox"/>	<input type="checkbox"/>	<input type="checkbox"/>	<input type="checkbox"/>	<input type="checkbox"/>	<input type="checkbox"/>	<input type="checkbox"/>	<input type="checkbox"/>	<input type="checkbox"/>	<input type="checkbox"/>	<input type="checkbox"/>	<input type="checkbox"/>	<input type="checkbox"/>	<input type="checkbox"/>
8. Restart the engine 5 min. before the official beginning of Stage I.	<input checked="" type="checkbox"/>	<input type="checkbox"/>	<input checked="" type="checkbox"/>	<input type="checkbox"/>	<input checked="" type="checkbox"/>	<input type="checkbox"/>	<input checked="" type="checkbox"/>	<input type="checkbox"/>	<input checked="" type="checkbox"/>	<input type="checkbox"/>	<input checked="" type="checkbox"/>	<input type="checkbox"/>	<input checked="" type="checkbox"/>	<input type="checkbox"/>	<input checked="" type="checkbox"/>	<input type="checkbox"/>	<input checked="" type="checkbox"/>	<input type="checkbox"/>	<input checked="" type="checkbox"/>	<input type="checkbox"/>	<input checked="" type="checkbox"/>	<input type="checkbox"/>	<input checked="" type="checkbox"/>	<input type="checkbox"/>	
9. AMOUNT OF OIL DRAINED If the oil level is high in Step 7, record the amount of oil drained in oz to reduce the level to full. If no oil is drained, enter "zero."	<input type="checkbox"/>	<input type="checkbox"/>	<input type="checkbox"/>	<input type="checkbox"/>	<input type="checkbox"/>	<input type="checkbox"/>	<input type="checkbox"/>	<input type="checkbox"/>	<input type="checkbox"/>	<input type="checkbox"/>	<input type="checkbox"/>	<input type="checkbox"/>	<input type="checkbox"/>	<input type="checkbox"/>	<input type="checkbox"/>	<input type="checkbox"/>	<input type="checkbox"/>	<input type="checkbox"/>	<input type="checkbox"/>	<input type="checkbox"/>	<input type="checkbox"/>	<input type="checkbox"/>	<input type="checkbox"/>	<input type="checkbox"/>	<input type="checkbox"/>
10. FINAL OIL LEVEL Enter "O" for full or the number of oz low indicated after completion of Step 9.	<input type="checkbox"/>	<input type="checkbox"/>	<input type="checkbox"/>	<input type="checkbox"/>	<input type="checkbox"/>	<input type="checkbox"/>	<input type="checkbox"/>	<input type="checkbox"/>	<input type="checkbox"/>	<input type="checkbox"/>	<input type="checkbox"/>	<input type="checkbox"/>	<input type="checkbox"/>	<input type="checkbox"/>	<input type="checkbox"/>	<input type="checkbox"/>	<input type="checkbox"/>	<input type="checkbox"/>	<input type="checkbox"/>	<input type="checkbox"/>	<input type="checkbox"/>	<input type="checkbox"/>	<input type="checkbox"/>	<input type="checkbox"/>	<input type="checkbox"/>
11. OPERATOR'S INITIALS	<input type="checkbox"/>	<input type="checkbox"/>	<input type="checkbox"/>	<input type="checkbox"/>	<input type="checkbox"/>	<input type="checkbox"/>	<input type="checkbox"/>	<input type="checkbox"/>	<input type="checkbox"/>	<input type="checkbox"/>	<input type="checkbox"/>	<input type="checkbox"/>	<input type="checkbox"/>	<input type="checkbox"/>	<input type="checkbox"/>	<input type="checkbox"/>	<input type="checkbox"/>	<input type="checkbox"/>	<input type="checkbox"/>	<input type="checkbox"/>	<input type="checkbox"/>	<input type="checkbox"/>	<input type="checkbox"/>	<input type="checkbox"/>	<input type="checkbox"/>

Note: If the FINAL OIL LEVEL (Step 10) is more than 12 ounces low during the first 192 hours of the test, the test must be invalidated because of excessive oil consumption.

OIL CONSUMPTION - Calculate the oil consumption per 24-hour period according to the equations shown below.

OIL CONSUMPTION (oz per 24-hour period Cycles 1-69) = 8 - x - y - z

OIL CONSUMPTION (oz per 24-hour period Cycles 69-72) = 1 - x - y - z

where x = the FINAL OIL LEVEL of the previous period
y = the amount of oil removed in Step 9 of the current period
z = the FINAL OIL LEVEL of the current period

NOTE 1—SI Equivalents—2 oz (54 mL) 5 oz (148 mL).
FIG. A5.1 Oil Sampling, Addition, and Leveling Data Record

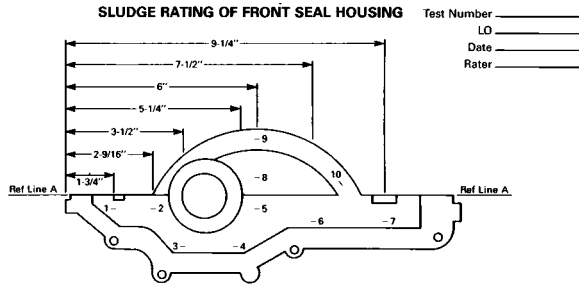

Test Number _____
 LO _____
 Date _____
 Rater _____

Rating sites 1, 2, and 5 are located 0.25 in. below Reference Line A.
 Rating sites 6 and 7 are located 0.5 in. below Reference Line A.
 Rating sites 3 and 4 are located 1.5 in. below Reference Line A.
 Rating site 9 is located 1.5 in. above Reference Line A.
 Rating site 10 is located 0.75 in. above Reference Line A.
 The depth gauge should be oriented as indicated by the (-) and the dimensions shown on the drawing.

Depth Scale	Site										Total Checks	% Coverage	Volume Factor
	1	2	3	4	5	6	7	8	9	10			
Clean													
1/4A													
1/2A													
3/4A													
A													
AB													
B													
BC													
C													
D													
E													
F													
G													
H													
I													
J													
Grand Total													

Front Seal Housing Sludge Rating _____

FIG. A6.2 Sludge Rating of Front Seal Housing

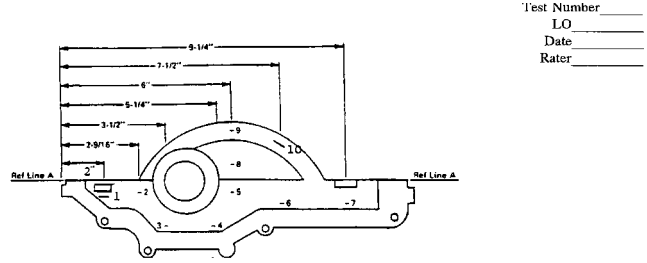

Test Number _____
 LO _____
 Date _____
 Rater _____

Rating site 1 is located 0.5 in. below Reference Line A.
 Rating sites 2 and 5 are located 0.25 in. below Reference Line A.
 Rating sites 6 and 7 are located 0.5 in. below Reference Line A.
 Rating sites 3 and 4 are located 1.5 in. below Reference Line A.
 Rating site 8 is located 0.5 in. above Reference Line A.
 Rating site 9 is located 1.5 in. above Reference Line A.
 Rating site 10 is located 0.75 in. above Reference Line A.
 The depth gauge should be oriented as indicated by the (-) and the dimensions shown on the drawing.

Depth Scale	Site										Total Checks	% Coverage	Volume Factor
	1	2	3	4	5	6	7	8	9	10			
Clean													
1/4A													
1/2A													
3/4A													
A													
AB													
B													
BC													
C													
D													
E													
F													
G													
H													
I													
J													
GRAND TOTAL													

Front Seal Housing Sludge Rating _____

FIG. A6.3 Sludge Rating of Front Seal Housing (1989 and Later Kits)

ASME D 5302

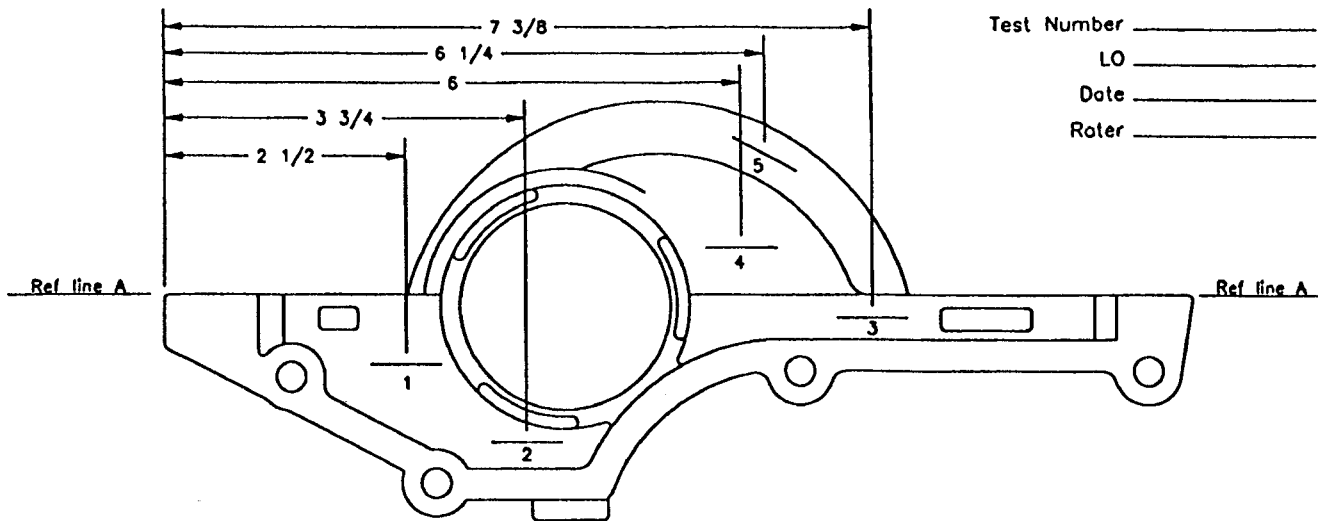

Rating site 1 is located 0.75 in. below Reference Line A.
 Rating site 2 is located 1.5 in. below Reference Line A.
 Rating site 3 is located 0.25 in. below Reference Line A.
 Rating site 4 is located 0.5 in. above Reference Line A.
 Rating site 5 is located 1.5 in. above Reference Line A.
 The depth gauge should be oriented as indicated by the (→) and the dimensions shown on the drawing.

Depth Scale	Site					Total Checks	% Coverage	Volume Factor
	1	2	3	4	5			
Clean								
1/4A								
1/2A								
3/4A								
A								
AB								
B								
BC								
C								
D								
E								
F								
G								
H								
I								
J								
Grand Total								

Front Seal Housing Sludge Rating _____

FIG. A6.4 Sludge Rating of Front Seal Housing (1992)

SLUDGE RATING OF ENGINE BLOCK

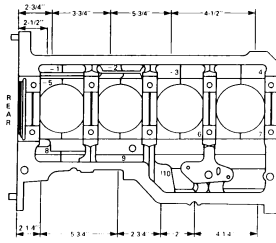

Test Number _____
 LO _____
 Date _____
 Rater _____

Rating sites 1, 2, 3, and 4 are located 1.0 in. from the inside edge of the gasket mounting surface.
 Rating sites 5, 6, and 7 are located 0.5 in. from the cylinder bore.
 Rating sites 8 and 9 are located 1.125 in. from the inside edge of the gasket mounting surface.
 Rating site 10 is located 1.0 in. from the inside edge of the gasket mounting surface.
 The depth gauge should be oriented as indicated by the (-) and the dimensions shown on the drawing.

Depth Scale	Site										Total Checks	% Coverage	Volume Factor
	1	2	3	4	5	6	7	8	9	10			
Clean													
1/4A													
1/2A													
3/4A													
A													
AB													
B													
BC													
C													
D													
E													
F													
G													
H													
I													
J													
	Grand Total												

Engine Block Sludge Rating _____

FIG. A6.5 Sludge Rating of Engine of Block

SLUDGE RATING OF OIL PAN

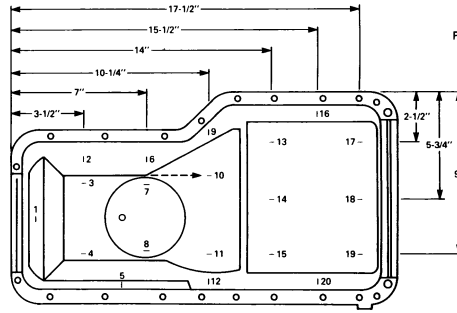

Test Number _____
 LO _____
 Date _____
 Rater _____

Rating sites 3 and 4 are located 1.0 in. from the side of the oil pan.
 Rating sites 7 and 8 are located 0.75 in. from the side of the oil pan.
 The depth gauge should be oriented as indicated by the (-) and the dimensions shown on the drawing.

Depth Scale	Site																				Total Checks	% Coverage	Volume Factor			
	1	2	3	4	5	6	7	8	9	10	11	12	13	14	15	16	17	18	19	20						
Clean																										
1/4A																										
1/2A																										
3/4A																										
A																										
AB																										
B																										
BC																										
C																										
D																										
E																										
F																										
G																										
H																										
I																										
J																										
	GRAND TOTAL																									

Oil Pan Sludge Rating _____

FIG. A6.6 Sludge Rating of Oil Pan

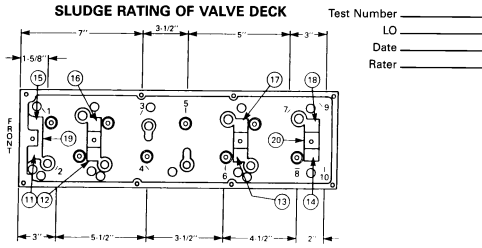

Rating sites 1, 2, 3, 4, 5, 6, 7, and 9 are located 1.0 in. from the outer edge of the cylinder head.

Rating sites 8 and 10 are located 1.125 in. from the outer edge of the cylinder head.

Rating sites 11, 12, 13, 14, 15, 16, 17, and 18 are located on the camshaft pedestal in line with the gasket mounting surface.

Rating sites 19 and 20 are located at the midpoint of the machined surface on the camshaft pedestal below the camshaft bearing.

The depth gauge should be oriented as indicated by the (-) and the dimensions shown on the drawing.

Depth Scale	Site																				Total Checks	% Coverage	Volume Factor				
	1	2	3	4	5	6	7	8	9	10	11	12	13	14	15	16	17	18	19	20							
Clean																											
1/4A																											
1/2A																											
3/4A																											
A																											
AB																											
B																											
BC																											
C																											
D																											
E																											
F																											
G																											
H																											
I																											
J																											
	GRAND TOTAL																										

Valve Deck Sludge Rating _____

FIG. A6.7 Sludge Rating of Valve Deck

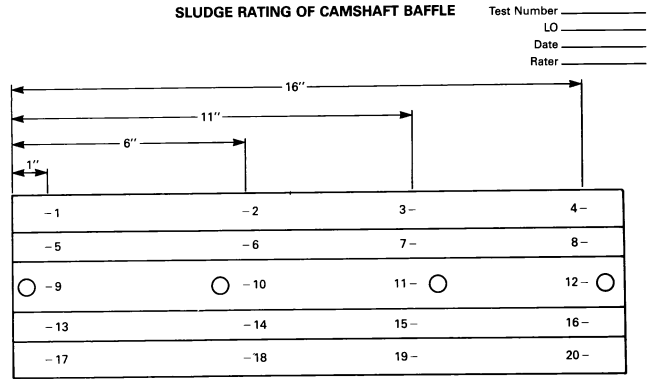

All rating sites are located according to the dimensions shown and at the midpoint of the appropriate plane.

The depth gauge should be oriented as indicated by the (-).

Depth Scale	Site																				Total Checks	% Coverage	Volume Factor				
	1	2	3	4	5	6	7	8	9	10	11	12	13	14	15	16	17	18	19	20							
Clean																											
1/4A																											
1/2A																											
3/4A																											
A																											
AB																											
B																											
BC																											
C																											
D																											
E																											
F																											
G																											
H																											
I																											
J																											
	GRAND TOTAL																										

Camshaft Baffle Sludge Rating _____

FIG. A6.8 Sludge Rating of Cam Cover Baffle

VARNISH RATING OF ROCKER ARM COVER Test Number _____
 LO _____
 Date _____
 Rater _____

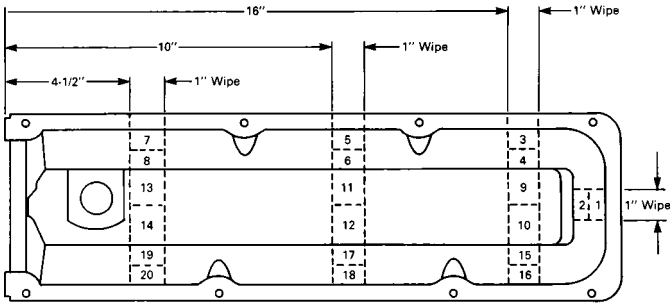

Area	Rating
1	
2	
3	
4	
5	
6	
7	
8	
9	
10	
Total	

Area	Rating
11	
12	
13	
14	
15	
16	
17	
18	
19	
20	
Total	

Rocker Arm Cover Varnish Rating = $\frac{\text{Total} + \text{Total}}{20} = \underline{\hspace{2cm}}$

FIG. A6.9 Varnish Rating of Rocker Arm Cover

VARNISH RATING OF OIL PAN Test Number _____
 LO _____
 Date _____
 Rater _____

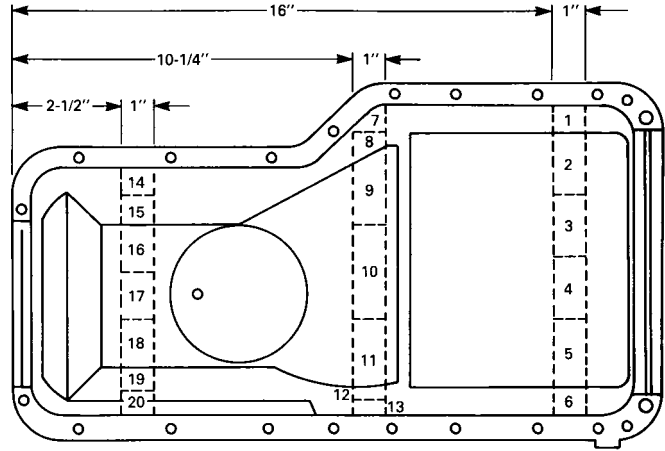

Area	Rating
1	
2	
3	
4	
5	
6	
7	
8	
9	
10	
Total	

Area	Rating
11	
12	
13	
14	
15	
16	
17	
18	
19	
20	
Total	

Oil Pan Varnish Rating = $\frac{\text{Total} + \text{Total}}{20} = \underline{\hspace{2cm}}$

FIG. A6.10 Varnish Rating of Oil Pan

VARNISH RATING OF CAMSHAFT BAFFLE

Test Number _____
 LO _____
 Date _____
 Rater _____

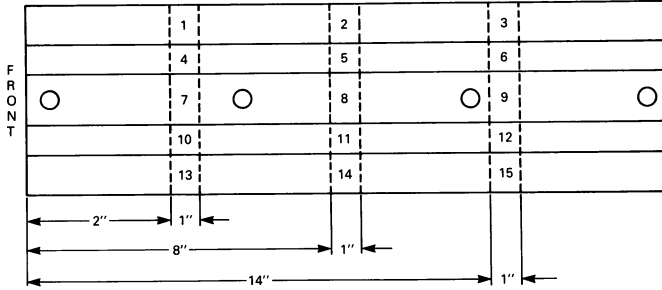

Area	Rating
1	
2	
3	
4	
5	
6	
7	
8	
9	
10	
11	
12	
13	
14	
15	
Total	

Camshaft Baffle Varnish Rating = $\frac{\text{Total}}{15} =$ _____

FIG. A6.11 Varnish Rating of Cam Cover Baffle

VARNISH RATING OF PISTON SKIRTS, CYLINDER WALLS, AND PISTON RING STICKING

Test No. _____
 LO _____
 Date _____
 Rater _____

Varnish Rating of Piston Skirts

Piston No.	Thrust	Anti-Thrust	Average
1			
2			
3			
4			
Total			
Average			

Piston Skirt Varnish Rating = $\frac{\text{Avg. Thrust} + \text{Avg. Anti-Thrust}}{2} =$ _____

Piston Ring Sticking

Piston No.	Top Ring	2nd Ring	Oil Ring
1			
2			
3			
4			
Total Hot Stuck			
Total Cold Stuck			

0 = Free Ring
 T = Tight Ring
 H = Hot Stuck Ring
 C = Cold Stuck Ring
 Oil rings will either be cold stuck or free.

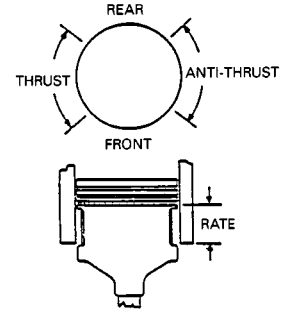

Varnish Rating of Cylinder Walls

Cylinder No.	Area				Average
	Thrust	Anti-Thrust	Front	Rear	
1					
2					
3					
4					
Total					

FIG. A6.12 Varnish Ratings of Piston Skirts and Cylinder Walls and Rating for Ring Sticking

ASTM D 5302

Pump Relief Valve & Intake Valves

CLOGGING OF OIL RINGS, OIL SCREEN, PCV VALVE, AND CAMSHAFT LOBE HOLES

Test No. _____
 Lo _____
 Date _____
 Rater _____

STICKING OF HYDRAULIC LIFTERS

VARNISH RATING OF OIL PUMP RELIEF VALVE, AND INTAKE VALVE DEPOSITS

Piston No.	Clogging, %	Debris, %	Sludge, %
1			
2			
3			
4			
Average			

Camshaft Lobe Hole Clogging

Lobe Number	Baseline Flow Rate	Final Flow Rate	Flow Rate	Flow Rate Reduction, %	Plugged
1E					
1I					
2E					
2I					
3E					
3I					
4E					
4I					

Hydraulic Lifter Sticking

Lifter Number	Stuck Plunger	Partially Stuck Plunger
1E		
1I		
2E		
2I		
3E		
3I		
4E		
4I		
5E		
5I		
Total		

Intake Valve Deposits

Valve Number	Rating
1	
2	
3	
4	
Average	

Oil Pump Relief Valve Varnish

Ring Number	Varnish
1	
2	
3	
4	
Average	

PCV Valve Clogging

Flow Rate, cfm				Flow Rate Difference		Clogging, %	
18 in. Hg ΔP		8 in. Hg ΔP		18 in. Hg ΔP	8 in. Hg ΔP	18 in. Hg ΔP	8 in. Hg ΔP
Before Test	After Test	Before Test	After Test	(Before - After, cfm)			

FIG. A6.13 Rating of Oil Rings, Oil Screen, PCV Valve, Cam Lobe Holes, Hydraulic Lifters, Oil Pump Relief Valve, and Intake Valves

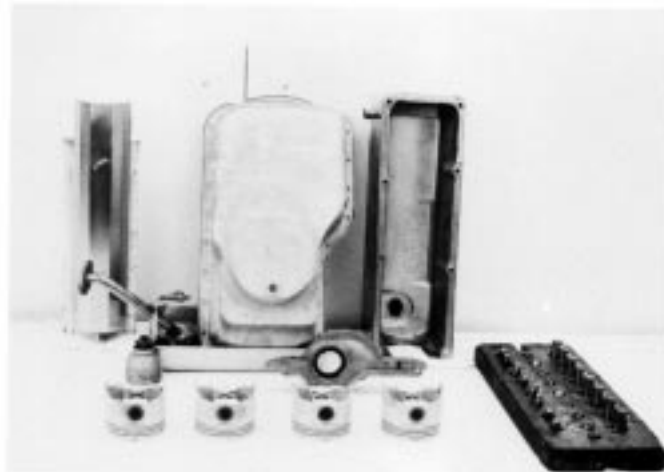
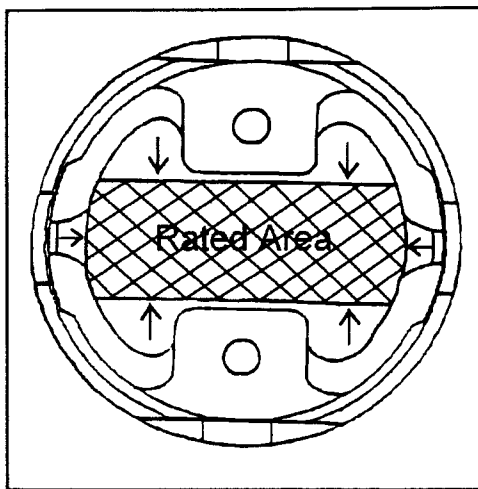

FIG. A6.14 Typical Parts Layout for Rating (see 12.6.3)

Rated by _____
 Engine No. _____

Date _____
 Test No. _____
 Oil Code _____



Piston	Area	Intensity	Merit	Rating
1)	_____ _____ _____ _____ _____	_____ _____ _____ _____ _____	_____ _____ _____ _____ _____	_____
2)	_____ _____ _____ _____ _____	_____ _____ _____ _____ _____	_____ _____ _____ _____ _____	_____
3)	_____ _____ _____ _____ _____	_____ _____ _____ _____ _____	_____ _____ _____ _____ _____	_____
4)	_____ _____ _____ _____ _____	_____ _____ _____ _____ _____	_____ _____ _____ _____ _____	_____
			Average	_____

FIG. A6.15 Piston Undercrown Deposit Breakdown Sheet

Rated by _____
Engine No. _____
Oil Code _____

Date _____
Test No. _____

Piston	Area	Intensity	Merit	Rating
1)	_____	_____	_____	_____
	_____	_____	_____	
	_____	_____	_____	
	_____	_____	_____	
	_____	_____	_____	
	_____	_____	_____	
	_____	_____	_____	
	_____	_____	_____	
	_____	_____	_____	
	_____	_____	_____	
2)	_____	_____	_____	_____
	_____	_____	_____	
	_____	_____	_____	
	_____	_____	_____	
	_____	_____	_____	
	_____	_____	_____	
	_____	_____	_____	
	_____	_____	_____	
	_____	_____	_____	
	_____	_____	_____	
3)	_____	_____	_____	_____
	_____	_____	_____	
	_____	_____	_____	
	_____	_____	_____	
	_____	_____	_____	
	_____	_____	_____	
	_____	_____	_____	
	_____	_____	_____	
	_____	_____	_____	
	_____	_____	_____	
4)	_____	_____	_____	_____
	_____	_____	_____	
	_____	_____	_____	
	_____	_____	_____	
	_____	_____	_____	
	_____	_____	_____	
	_____	_____	_____	
	_____	_____	_____	
	_____	_____	_____	
	_____	_____	_____	
Average				_____

FIG. A6.16 Second Land Deposit Breakdown Sheet

Rated by _____
 Engine No. _____
 Oil Code _____

Date _____
 Test No. _____

Piston	Area	Intensity	Merit	Rating
1)	_____	_____	_____	
	_____	_____	_____	
	_____	_____	_____	
	_____	_____	_____	
	_____	_____	_____	
	_____	_____	_____	
	_____	_____	_____	
	_____	_____	_____	
	_____	_____	_____	
	_____	_____	_____	_____
2)	_____	_____	_____	
	_____	_____	_____	
	_____	_____	_____	
	_____	_____	_____	
	_____	_____	_____	
	_____	_____	_____	
	_____	_____	_____	
	_____	_____	_____	
	_____	_____	_____	
	_____	_____	_____	_____
3)	_____	_____	_____	
	_____	_____	_____	
	_____	_____	_____	
	_____	_____	_____	
	_____	_____	_____	
	_____	_____	_____	
	_____	_____	_____	
	_____	_____	_____	
	_____	_____	_____	
	_____	_____	_____	_____
4)	_____	_____	_____	
	_____	_____	_____	
	_____	_____	_____	
	_____	_____	_____	
	_____	_____	_____	
	_____	_____	_____	
	_____	_____	_____	
	_____	_____	_____	
	_____	_____	_____	
	_____	_____	_____	_____
Average				_____

FIG. A6.18 Crown Land Deposit Breakdown Sheet

Rated by _____
 Engine No. _____
 Oil Code _____

Date _____
 Test No. _____

Cylinder	Before	After	Difference (bore wear, mils)	
1)				
Top	_____	_____	_____	Cylinder
Middle	_____	_____	_____	Average (mils)
Bottom	_____	_____	_____	_____
2)				
Top	_____	_____	_____	Cylinder
Middle	_____	_____	_____	Average (mils)
Bottom	_____	_____	_____	_____
3)				
Top	_____	_____	_____	Cylinder
Middle	_____	_____	_____	Average (mils)
Bottom	_____	_____	_____	_____
4)				
Top	_____	_____	_____	Cylinder
Middle	_____	_____	_____	Average (mils)
Bottom	_____	_____	_____	_____

Average Cylinder Bore Wear _____
 (mils)

Max Cylinder Bore Wear _____
 (mils)

FIG. A6.19 Cylinder Bore Wear

A7. FINAL REPORT FORMS AND PHOTOGRAPHS

A7.1 Report Forms—See Figs. A7.1-A7.22.

**TEST METHOD D5302
(SEQUENCE VE)
VERSION 19970902**

CONDUCTED FOR

TSTSPON1

TSTSPON2

LABVALID	V = VALID
	I = INVALID
	N = RESULTS CAN NOT BE INTERPRETED AS REPRESENTATIVE OF OIL PERFORMANCE (NON-REFERENCE OIL) AND SHALL NOT BE USED FOR MULTIPLE TEST ACCEPTANCE

Test Number			
Test Stand:	STAND	Runs Between Calibration Tests:	RSTRUN/STRUN
		Total Runs on Test Stand:	RTOTSRUN/TOTSTRUN
Date Completed:	RDTCOMP/DTCOMP	End of Test Time:	REOTIME/EOTIME
Oil Code ^A:	CMIR/OILCODE		
Formulation/Stand Code: FORM			
Alternate Codes	ALTCODE1	ALTCODE2	ALTCODE3

In my opinion this test OPVALID been conducted in a valid manner in accordance with the Test Method D 5302 and the appropriate amendments through the Information Letter system. The remarks included in the report describe the anomalies associated with this test.

The test stand and laboratory have been calibrated in accordance with the requirements specified in Test Method D 5302 and the appropriate amendments through the Information Letter system.

^ACMIR/Oil Code

SUBMITTED BY:

SUBLAB

Testing Laboratory

SUBSIGIM

Signature

SUBNAME

Typed Name

SUBTITLE

Title

FIG. A7.1 Test Report Cover

(SEQUENCE VE)
RATING AND MEASUREMENTS SUMMARY

Laboratory LAB	Oil Code OILCODE	SAE Viscosity Grade SAEVISC
Calibration Test Number A STAND - RSTRUN - RTOTSRUN	TMC Oil Code IND	Date/Time Calibrated RDTCOMP / RBOBTIME
Test Number STAND - STRUN - TOTSTRUN	Test Length TESTLEN	Date/Time Completed DTCOMP / EOTIME
Engine Number ENGINE	Nominal Piston Oversize NOMPISOV	Fuel Batch FUELBTID
Date/Time Started DTSTRT / STRTIME	Internal Oil Code LABOCODE	
Formulation/Stand Code: FORM		

S L U D G E		Rating (Reported Units)	Rating (Trans.)	Industry Correction Factor (Transformed)	Corrected Rating (Transformed)	Severity Adjustment (Transformed)	Final Rating Value (Transformed)	Final Rating Value (Reported Units)
	Rocker Arm Cover	RACSRT	TRANRACS	RACCF	TRACSCOR	RACSSA	TRACSFNL	RACSFNL
	Camshaft Baffle	CAMBSRT						
	Valve Deck	VLVDCRT						
	Front Seal Housing	FSLHSRT						
	Cylinder Block	CYBLKRT						
	Oil Pan	OILPNSRT						
	Average Engine Sludge	AES	TRANAES	AESCF	TAESCOR	AESSA	TAESFNL	AESFNL

V A R N I S H							
	Piston Skirts, merits	PIKVRT		PIKVCF		PSVSA	PIKVFNL
	Rocker Arm Cover, merits	RACVRT					
	Camshaft Baffle, merits	CAMBFVRT					
	Cylinder Walls, merits	CYLWVRT					
	Oil Pan, merits	OILPNVRT					
Average Engine Varnish, merits	AEV		AEVCF		AEVSA	AEVFNL	

W E A R								
	ACW, micrometers	ACW	TRANACW	ACWCF	TACWCOR	ACWSA	TACWFNL	ACWFNL
	MCW, micrometers	MCW	TRANMCW	MCWCF	TMCWCOR	MCWSA	TMCWFNL	MCWFNL
	Avg. Rocker Arm, mg	ARAW						
	Max. Rocker Arm, mg	MAXRAW						
	Avg. Top Ring Inc., mils	ATRGINC						
	Max. Top Ring Inc., mils	MXTRGINC						
	Avg. Rod Bearing, mg	ARBWL						
Max. Rod Bearing, mg	MAXBWL							

C L O G G I N G		
	Oil Screen Sludge, %	OSCRNSLG
	Oil Screen Debris, %	OSCRNDEB
	Oil Ring, %	OILRING
	PCV Valve at 18 in. Hg., %	PCV18
	PCV Valve at 8 in. Hg., %	PCV8
Number of Camshaft Lobe Holes	NOCAMLOB	

O D E P O S I T S		
	Average Crown Land Deposit, merits	AVGCLD
	Average Second Land Deposit, merits	AVGSLD
	Average Oil Ring Land Deposits, merits	AVGORLD
	Average Piston Under Crown Deposit, merits	AVGPUCD
	Intake Valve Deposits, merits	INVLVDEP
Number of Stuck Lifter Plungers	NSLFTPLG	
Number of Hot Stuck Compression Rings	NHSCMPRG	
Number of Stuck Oil Rings	NSTKORNG	

ADDITIONAL INFORMATION

Oil Consumption, fl. oz.	OILCON
--------------------------	--------

Average Blowby Flow Rate, cfm	ACBLWRT1
-------------------------------	----------

^A Test number consists of the stand number, number of runs between calibration tests and total number of runs on the stand.

FIG. A7.2 Rating and Measurement Summary, Non-Reference Oil Test

(SEQUENCE VE)
Rating and Measurement Summary, Calibration Test Results

Laboratory	LAB	Oil Code	CMIR	SAE Viscosity Grade	RSAEISC
Test Number ^A	STAND - RSTRUN - RTOTSRUN	Test Length	RTESTLEN	Date/Time Completed	RDTCOMP / RBOTTIME
Engine Number	RENGINE	Nominal Piston Oversize	RNOMPISO	Fuel Batch	RFUELBID
Date/Time Started	RDTSTRT / RSTRTIME	Internal Oil Code	RLABCODE		

S L U D G E		Rating (Reported Units)	Rating (Transformed)	Industry Correction Factor (Transformed)	Corrected Rating (Transformed)	Final Rating (Reported Units)
	Rocker Arm Cover	RRACSRT	RTRNRACS	RACCF	RTRCSCOR	RRACSFNL
	Camshaft Baffle	RCAMBSRT				
	Valve Deck	RVLVDKRT				
	Front Seal Housing	RFLHSRT				
	Cylinder Block	RCYLBLRT				
	Oil Pan	ROIPLNRT				
	Average Engine Sludge	RAES	RTRANAES	AESCF	RTAESCOR	RAESFNL

V A R N I S H		Rating (Reported Units)	Rating (Transformed)	Industry Correction Factor (Transformed)	Corrected Rating (Transformed)	Final Rating (Reported Units)
	Piston Skirts, merits	RPIKVRT		PIKVCVF		RPSKVFNL
	Rocker Arm Cover, merits	RRACVRT				
	Camshaft Baffle, merits	RCAMBVRT				
	Cylinder Walls, merits	RCYLWVRT				
	Oil Pan, merits	ROIPLNVR				
Average Engine Varnish, merits	RAEV		AEVCF		RAEVFNL	

W E A R		Rating (Reported Units)	Rating (Transformed)	Industry Correction Factor (Transformed)	Corrected Rating (Transformed)	Final Rating (Reported Units)
	ACW, micrometers	RACW	RTACW	ACWCF	RTACWCOR	RACWFNL
	MCW, micrometers	RMCW	RTMCW	MCWCF	RTMCWCOR	RMCWFNL
	Avg. Rocker Arm, mg	RARAW				
	Max. Rocker Arm, mg	RMAXRAW				
	Avg. Top Ring Inc., mils	RATRGINC				
	Max. Top Ring Inc., mils	RXTRGINC				
Avg. Rod Bearing, mg	RARBWL					
Max. Rod Bearing, mg	RMAXBWL					

C L O G G I N G		Rating (Reported Units)	Rating (Transformed)	Industry Correction Factor (Transformed)	Corrected Rating (Transformed)	Final Rating (Reported Units)
	Oil Screen Sludge, %	ROSCRSLG				
	Oil Screen Debris, %	ROSCRDEB				
	Oil Ring, %	ROI LRING				
	PCV Valve at 18 in. Hg., %	RPCV18				
	PCV Valve at 8 in. Hg., %	RPCV8				
	Number of Camshaft Lobe Holes	RNCAMLOB				

O D E P O S I T S		Rating (Reported Units)	Rating (Transformed)	Industry Correction Factor (Transformed)	Corrected Rating (Transformed)	Final Rating (Reported Units)
	Average Crown Land Deposit, merits					RAVGCLD
	Average Second Land Deposit, merits					RAVGSLD
	Average Oil Ring Land Deposit, merits					RAVGORLD
	Average Piston UnderCrown Deposit, merits					RAVGPUCD
	Intake Valve Deposit, merits					RINVDEP
Number of Stuck Lifter Plungers					RSLFTPLG	
Number of Hot Stuck Compression Rings					RHSCMPRG	
Number of Stuck Oil Rings					RSTKORNG	

Additional Information			
Oil Consumption, fl. oz.	ROI LCON	Average Blowby Flow Rate, cfm	RABLBYRT

S T A T I S T I C S	Reference Oil	IND	Statistics Date	STATDATE	
	Parameter	Target	S	Delta/s	
	AES	TARGAES	SAES	DELAES	DELSAES
	RACS	TARRACS	SRACS	DELRACS	DELSRACS
	APV	TARAPV	SAPV	DELAPV	DELSAPV
	AEV	TARAEV	SAEV	DELAEV	DELSAEV
	ACW	TARACW	SACW	DELACW	DELSACW
	MCW	TARMCW	SMCW	DELMCW	DELSMCW

^A Test number consists of the stand number, number of runs between calibration tests, and total number of runs on the stand.

FIG. A7.3 Ratings and Measurement Summary, Calibration Test

(SEQUENCE VE)
OPERATIONAL SUMMARY

LABORATORY : LAB	OIL CODE: CMIR/OILCODE								
TEST NUMBER ^A : STAND - RSTRUN/STRUN - RTOTSRUN/TOTSTRUN	DATE COMPLETED: RDTCOMP/DTCOMP								
Formulation/Stand Code: FORM									
PARAMETER	STAGE I			STAGE II			STAGE III		
	MAX	MIN	AVG	MAX	MIN	AVG	MAX	MIN	AVG
Engine speed, r/min	XRPM1	IRPM1	ARPM1	XRPM2	IRPM2	ARPM2	XRPM3	IRPM3	ARPM3
Engine Power, bhp	XPWR1	IPWR1	APWR1	XPWR2	IPWR2	APWR2	XPWR3	IPWR3	APWR3
Engine Oil In Temperature, °F	XENGOIN1	IENGOIN1	AENGOIN1	XENGOIN2	IENGOIN2	AENGOIN2	XENGOIN3	IENGOIN3	AENGOIN3
Engine Oil Delta Temp. (Out-In), °F	XENGODT1	IENGODT1	AENGODT1	XENGODT2	IENGODT2	AENGODT2	XENGODT3	IENGODT3	AENGODT3
Pump Oil Pressure, psig	XPMPOPR1	IPMPOPR1	APMPOPR1	XPMPOPR2	IPMPOPR2	APMPOPR2	XPMPOPR3	IPMPOPR3	APMPOPR3
Engine Oil Pressure, psig	XENGOPR1	IENGOPR1	AENGOPR1	XENGOPR2	IENGOPR2	AENGOPR2	XENGOPR3	IENGOPR3	AENGOPR3
Cylinder Head Oil Pressure, psig	XCYLOPR1	ICYLOPR1	ACYLOPR1	XCYLOPR2	ICYLOPR2	ACYLOPR2	XCYLOPR3	ICYLOPR3	ACYLOPR3
Delta Pressure (Pump-Engine), psi	XDPPE1	IDPPE1	ADPPE1	XDPPE2	IDPPE2	ADPPE2	XDPPE3	IDPPE3	ADPPE3
Delta Pressure (Engine-Head), psi	XDPEH1	IDPEH1	ADPEH1	XDPEH2	IDPEH2	ADPEH2	XDPEH3	IDPEH3	ADPEH3
Engine Coolant Out Temperature, °F	XCOLOUT1	ICOLOUT1	ACOLOUT1	XCOLOUT2	ICOLOUT2	ACOLOUT2	XCOLOUT3	ICOLOUT3	ACOLOUT3
Eng. Coolant Delta Temp. (Out-In), °F	XCOLDT1	ICOLDT1	ACOLDT1	XCOLDT2	ICOLDT2	ACOLDT2	XCOLDT3	ICOLDT3	ACOLDT3
Engine Coolant Flow Rate, gal/min	XCOLFRT1	ICOLFRT1	ACOLFRT1	XCOLFRT2	ICOLFRT2	ACOLFRT2	---	---	---
Engine Coolant Pressure, psig	XCOLPRE1	ICOLPRE1	ACOLPRE1	XCOLPRE2	ICOLPRE2	ACOLPRE2	XCOLPRE3	ICOLPRE3	ACOLPRE3
Exhaust Manifold Coolant Temp., °F	XEXCOOL1	IEXCOOL1	AEXCOOL1	XEXCOOL2	IEXCOOL2	AEXCOOL2	XEXCOOL3	IEXCOOL3	AEXCOOL3
RAC Coolant In Temperature, °F	XRACCTP1	IRACCTP1	ARACCTP1	XRACCTP2	IRACCTP2	ARACCTP2	XRACCTP3	IRACCTP3	ARACCTP3
RAC Coolant Flow Rate, gal/min	XRACCFR1	IRACCFR1	ARACCFR1	---	---	---	XRACCFR3	IRACCFR3	ARACCFR3
Intake Air Temperature, °F	XINAIRT1	IINAIRT1	AINAIRT1	XINAIRT2	IINAIRT2	AINAIRT2	XINAIRT3	IINAIRT3	AINAIRT3
Intake Air Specific Humidity, grains/lb	XAIRHUM1	IAIRHUM1	AIRHUM1	XAIRHUM2	IIRHUM2	AIRHUM2	XAIRHUM3	IIRHUM3	AIRHUM3
Intake Air Pressure, in. H ₂ O gage	XINAIRP1	IINAIRP1	AINAIRP1	XINAIRP2	IINAIRP2	AINAIRP2	XINAIRP3	IINAIRP3	AINAIRP3
Corrected Blowby Flow Rate, ft ³ /min	XCBLWRT1	ICBLWRT1	ACBLWRT1	---	---	---	---	---	---
Crankcase Pressure, in. H ₂ O gage	XCCASEP1	ICCASEP1	ACCASEP1	XCCASEP2	ICCASEP2	ACCASEP2	XCCASEP3	ICCASEP3	ACCASEP3
Intake Manifold Vacuum, in. Hg gage	XIMNVAC1	IIMNVAC1	AIMNVAC1	XIMNVAC2	IIMNVAC2	AIMNVAC2	XIMNVAC3	IIMNVAC3	AIMNVAC3
Exhaust Back Pressure, in. Hg abs.	XEXBKPR1	IEXBKPR1	AEXBKPR1	XEXBKPR2	IEXBKPR2	AEXBKPR2	XEXBKPR3	IEXBKPR3	AEXBKPR3
Ignition Timing, °BTDC	XIGNTIM1	IIGNTIM1	AIGNTIM1	---	---	---	---	---	---
Fuel Consumption Rate, lb/hr	XFUELRT1	IFUELRT1	AFUELRT1	XFUELRT2	IFUELRT2	AFUELRT2	XFUELRT3	IFUELRT3	AFUELRT3
Exhaust Gas O ₂ , %	XEXHGO1	IEXHGO1	AEXHGO1	XEXHGO2	IEXHGO2	AEXHGO2	XEXHGO3	IEXHGO3	AEXHGO3
Exhaust Gas CO, %	XEXHCO1	IEXHCO1	AEXHCO1	XEXHCO2	IEXHCO2	AEXHCO2	XEXHCO3	IEXHCO3	AEXHCO3
Exhaust Gas NO _x , ppm	---	---	---	XEXHGN2	IEXHGN2	AEXHGN2	---	---	---

^A Test number consists of the stand number, number of runs between calibration tests, and total number of runs on the stand.

FIG. A7.4 Operational Summary

(SEQUENCE VE)
SUPPLEMENTAL OPERATIONAL DATA

Laboratory: LAB	Oil Code: CMIR/OILCODE
Test Number: ^A STAND - RSTRUN/STRUN - RTOTSRUN/TOTSTRUN	Date Completed: RDTCOMP/DTCOMP
Number of Remarks or Deviations: OPROCR	
Formulation/Stand Code: FORM	

<u>Item</u>	<u>Remark or Deviation</u>
ITEMH001	REMKH001

NOTE 1—Test number consists of the stand number, number of runs between calibration tests, and total number of runs on the stand.

FIG. A7.5 Supplemental Operational Data

**(SEQUENCE VE)
OIL ANALYSES**

Laboratory: LAB	Oil Code: CMIR/OILCODE
Test Number: STAND - RSTRUN/STRUN - RTOTSRUN/TOTSTRUN	Date Completed: RDTCOMP/DTCOMP
Formulation/Stand Code: FORM	

Test Hour	Fe ppm	Cu ppm	Si ppm	Viscosity @ 40°C cSt Test Method D445	Fuel Dilution % mass Test Method D3525 (modified)	Pentane Insolubles Test Method D893B
New Oil	FE_HNEW	CU_HNEW	SI_HNEW	VS40HNEW	---	---
12	FE_H012	CU_H012	SI_H012	VS40H012	FUELH012	---
108	FE_H108	CU_H108	SI_H108	VS40H108	FUELH108	PENTH108
204	FE_H204	CU_H204	SI_H204	VS40H204	FUELH204	PENTH204
288	FE_H288	CU_H288	SI_H288	VS40H288	FUELH288	PENTH288

FIG. A7.7 Oil Analyses

(SEQUENCE VE)

VALVE TRAIN INSPECTION DETAIL

Laboratory:	LAB	Oil Code:	CMIR/OILCODE
Test Number:	STAND - RSTRUN/STRUN - RTOTSRUN/TOTSTRUN	Date Completed:	RDTCOMP/DTCOMP
Formulation/Stand Code:	FORM		

Position	Cam Lobe Wear (micrometers)	Lobe Orifice Plugging % Air Flow Loss	Rocker Arm Wear mg	Valve Spring Load, lbf
1 (1E)	CAMW01	LOBPLG01	ROCKW01	VSPGLD01
2 (1I)	CAMW02	LOBPLG02	ROCKW02	VSPGLD02
3 (2E)	CAMW03	LOBPLG03	ROCKW03	VSPGLD03
4 (2I)	CAMW04	LOBPLG04	ROCKW04	VSPGLD04
5 (3E)	CAMW05	LOBPLG05	ROCKW05	VSPGLD05
6 (3I)	CAMW06	LOBPLG06	ROCKW06	VSPGLD06
7 (4E)	CAMW07	LOBPLG07	ROCKW07	VSPGLD07
8 (4I)	CAMW08	LOBPLG08	ROCKW08	VSPGLD08
Average	RACW/ACW	AVGLOBPL	ARAW	AVGSPGLO

Lobe	Lobe Hardness (> 50 Rockwell C) ^A	Rocker Arm Hardness (> 57 Rockwell C)
1E	LOBHRD01	RCKHRD01
1I	LOBHRD02	RCKHRD02
2E	LOBHRD03	RCKHRD03
2I	LOBHRD04	RCKHRD04
3E	LOBHRD05	RCKHRD05
3I	LOBHRD06	RCKHRD06
4E	LOBHRD07	RCKHRD07
4I	LOBHRD08	RCKHRD08

^A Camshafts with individual lobe hardness less than 50 Rockwell C may be used. Record lobe location(s) and hardness value(s) on the Supplemental Operational Data Form, Fig A7.5.

FIG. A7.8 Valve Train Inspection Detail

**(SEQUENCE VE)
VARNISH RATING OF PISTON SKIRTS
RATING OF RING LAND AND PISTON UNDER CROWN DEPOSITS**

Laboratory: LAB	Oil Code: CMIR/OILCODE
Test Number: STAND - RSTRUN/STRUN - RTOTSRUN/TOTSTRUN	Date Completed: RDTCOMP/DTCOMP
Formulation/Stand Code: FORM	

Piston Number	Thrust (Merits)	Antithrust (Merits)
1	PSVTH1	PSVAT1
2	PSVTH2	PSVAT2
3	PSVTH3	PSVAT3
4	PSVTH4	PSVAT4
Average	PSVTHAVG	PSVATAVG

$$\text{Piston Skirt Varnish} = \frac{\text{Average Thrust} + \text{Average Antithrust}}{2} = \text{RPISKVRT/PISKVRT}$$

Piston Number	Crown Land (Merits)	2nd Land (Merits)	Oil Ring Land (Merits)	Piston Undercrown (Merits)
1	CLD1	SECLD1	ORLD1	PISUC1
2	CLD2	SECLD2	ORLD2	PISUC2
3	CLD3	SECLD3	ORLD3	PISUC3
4	CLD4	SECLD4	ORLD4	PISUC4
Average	RAVGPUCD/AVGPUCD	RAVGSLD/AVGSLD	RAVGORLD/AVGORLD	RAVGCLD/AVGCLD

FIG. A7.9 Varnish Ratings of Piston Skirts

SEQUENCE VE
CORRECTED BLOWBY FLOWRATE PLOT

Formulation/Stand Code:
FORM

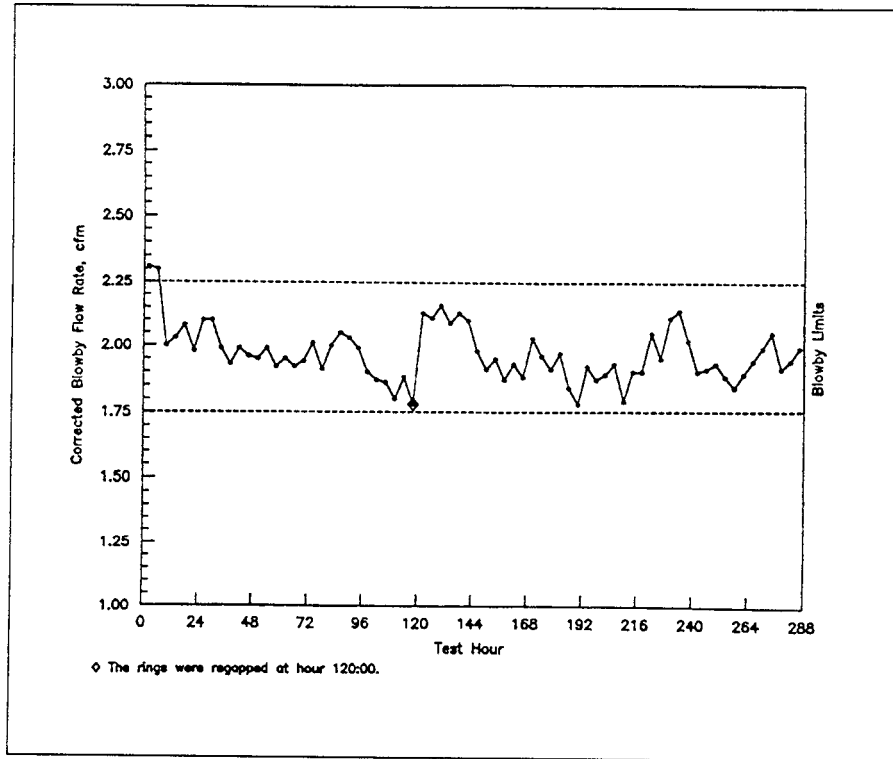

BIOWBYIM

FIG. A7.10 Corrected Blowby Plot

(SEQUENCE VE)

OIL ADDITION RECORD

Laboratory: LAB	Oil Code: CMIR/OILCODE
Test Number: STAND - RSTRUN/STRUN - RTOTSRUN/TOTSTRUN	Date Completed: RDTCOMP/DTCOMP
Formulation/Stand Code: FORM	

Cycle	Test Hour	Oil Consumption fl. oz.	Oil Level fl. oz.
6	23 h 35 min.	OILCH006	OILLH006
12	47 h 35 min.	OILCH012	OILLH012
18	71 h 35 min.	OILCH018	OILLH018
24	95 h 35 min.	OILCH024	OILLH024
30	119 h 35 min.	OILCH030	OILLH030
36	143 h 35 min.	OILCH036	OILLH036
42	167 h 35 min.	OILCH042	OILLH042
48	191 h 35 min.	OILCH048	OILLH048
54	215 h 35 min.	OILCH054	OILLH054
60	239 h 35 min.	OILCH060	OILLH060
66	263 h 35 min.	OILCH066	OILLH066
72	287 h 35 min.	OILCH072	OILLH072
Total Oil Consumption, fl. oz.:		ROILCON/OILCON	

FIG. A7.11 Oil Addition Record

SEQUENCE VE

ORIGIN OF SIGNIFICANT ENGINE PARTS

Laboratory: LAB	Oil Code: CMIR/OILCODE
Test Number: STAND - RSTRUN/STRUN - RTOTSRUN/TOTSTRUN	Date Completed: RDTCOMP/DTCOMP
Formulation/Stand Code: FORM	

ORIGIN OF SIGNIFICANT ENGINE PARTS

ENGINE PART	ORIGIN
Camshaft	CAMOGN
Connecting Rod Bearings	CRODBOGN
Cylinder Block	CYLBKOGN
Cylinder Head	CYLHDOGN
Pistons	PISTOGN
Piston Rings	PISRGOGN
Rocker Arms	RCKRAOGN

FIG. A7.12 Origin of Significant Engine Parts

CHARACTERISTICS OF THE DATA ACQUISITION SYSTEM

Laboratory: LAB	Test Stand: STAND
------------------------	--------------------------

PARAMETER (1)	SENSING DEVICE (2)	CALIBRATION FREQUENCY (3)	RECORD DEVICE (4)	OBSERVATION FREQUENCY (5)	RECORD FREQUENCY (6)	LOG FREQUENCY (7)	SYSTEM RESPONSE (8)
Temperature							
Oil Inlet	OILSENS	OILCALF	OILRECD	OILIOBSF	OILIRECF	OILIOLOGF	
RAC Inlet	RCCSENS	RCCCALF	RCCRECD	RCCIOBSF	RCCIRECF	RCCIOLOGF	
Coolant Outlet	COTSENS	COTCALF	COTRECD	COTOBSF	COTRECF	COTLOGF	
Other							
Speed	RPMSSENS	RPMCALF	RPMRECD	RPMOBSF	RPMRECF	RPMLOGF	RPMSYSR
Power	PWRSENS	PWRCALF	PWRRECD	PWROBSF	PWRRECF	PWRLOGF	PWRSYSR
CO	COSENS	COCALF	CORECD	COOBSF	CORECF	COLOGF	COSYSR
O ₂	O2SENS	O2CALF	O2RECD	O2OBSF	O2RECF	O2LOGF	O2SYSR
Timing	TIMGSENS	TIMGCALF	TIMGRECD	TIMGOBSF	TIMGRECF	TIMGLOGF	
Blowby	BLWGSSENS	BLWGCALF	BLWGRECD	BLWGOBSF	BLWGRECF	BLWGLOGF	
Exhaust Backpressure X	EXPRSENS	EXPRCALF	EXPRECD	EXPROBSF	EXPRECF	EXPRLOGF	
Engine Coolant Flow	CFLWSENS	CFLWCALF	CFLWRECD	CFLWOBSF	CFLWRECF	CFLWLOGF	
Rocker Arm Cover	RCCFSENS	RCCFCALF	RCCFRECD	RCCFOBSF	RCCFRECF	RCCFLOGF	

LEGEND:

- (1) OPERATING PARAMETER
- (2) THE TYPE OF DEVICE USED TO MEASURE TEMPERATURE, PRESSURE OR FLOW
- (3) FREQUENCY AT WHICH THE MEASUREMENT SYSTEM IS CALIBRATED
- (4) THE TYPE OF DEVICE WHERE DATA IS RECORDED
 LG - HANDLOG SHEET
 DL - AUTOMATIC DATA LOGGER
 SC - STRIP CHART RECORDER
 C/M - COMPUTER, USING MANUAL DATA ENTRY
 C/D - COMPUTER, USING DIRECT I/O ENTRY
- (5) DATA ARE OBSERVED BUT ONLY RECORDED IF OFF SPEC.
- (6) DATA ARE RECORDED BUT ARE NOT RETAINED AT EOT
- (7) DATA ARE LOGGED AS PERMANENT RECORD, NOTE SPECIFY IF:
 SS - SNAPSHOT TAKEN AT SPECIFIED FREQUENCY
 AG/X AVERAGE OF X DATA POINTS AT SPECIFIED FREQUENCY
- (8) TIME FOR THE OUTPUT TO REACH 63.2% OF FINAL VALUE FOR STEP CHANGE AT INPUT

FIG. A7.13 Characteristics of the Data Acquisition System

SEQUENCE VE

Rocker Cover and Camshaft Baffle Photographs

Laboratory: LAB	Oil Code: CMIR/OILCODE
Test Number: STAND - ASTRUN/STRUN - RTOTSRUN/TOTSTRUN	Date Completed: RDTCOMP/DTCOMP
Formulation/Stand Code: FORM	

RC_CSBIM



FIG. A7.14 Rocker Arm Cover and Camshaft Baffle Photographs

SEQUENCE VE

Oil Pan and Oil Screen Photographs

Laboratory: LAB	Oil Code: CMIR/OILCODE
Test Number: STAND - RSTRUN/STRUN - RTOTSRUN/TOTSTRUN	Date Completed: RDTCOMP/DTCOMP
Formulation/Stand Code: FORM	

OP_OSIM

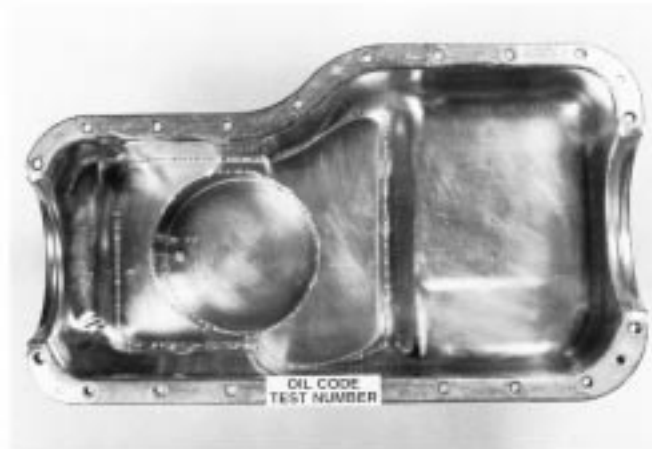

FIG. A7.15 Oil Pan and Oil Screen Photographs

SEQUENCE VE

Piston Skirt Photographs

Laboratory: LAB	Oil Code: CMIR/OILCODE
Test Number: STAND - RSTRUN/STRUN - RTOTSRUN/TOTSTRUN	Date Completed: RDTCOMP/DTCOMP
Formulation/Stand Code: FORM	

PISTONIM



FIG. A7.16 Piston Skirt Photographs

SEQUENCE VE

Camshaft Lobe Photographs

Laboratory: LAB	Oil Code: CMIR/OILCODE
Test Number: STAND - RSTRUN/STRUN - RTOTSRUN/TOTSTRUN	Date Completed: RDTCOMP/DTCOMP
Formulation/Stand Code: FORM	

CAMLOBIM



FIG. A7.17 Camshaft Lobe Photographs

SEQUENCE VE

Front Seal Housing and Rocker Arm Photographs

Laboratory: LAB	Oil Code: CMIR/OILCODE
Test Number: STAND - RSTRUN/STRUN - RTOTSRUN/TOTSTRUN	Date Completed: RDTCOMP/DTCOMP
Formulation/Stand Code: FORM	

FSH_RA1M

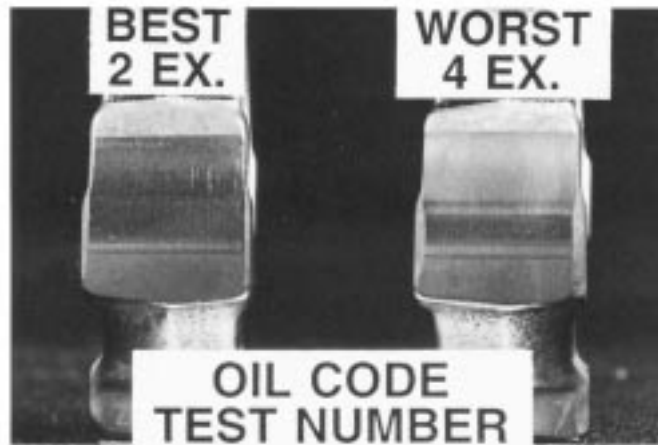

FIG. A7.18 Front Seal Housing and Rocker Arm Photographs

SEQUENCE VE

Sequence VE Sample Transition Plot

Laboratory: LAB	Oil Code: CMIR/OILCODE
Test Number: STAND - ASTRUN/STRUN - RTOTSRUN/TOTSTRUN	Date Completed: RDTCOMP/DTCOMP
Formulation/Stand Code: FORM	

TRANSIIM

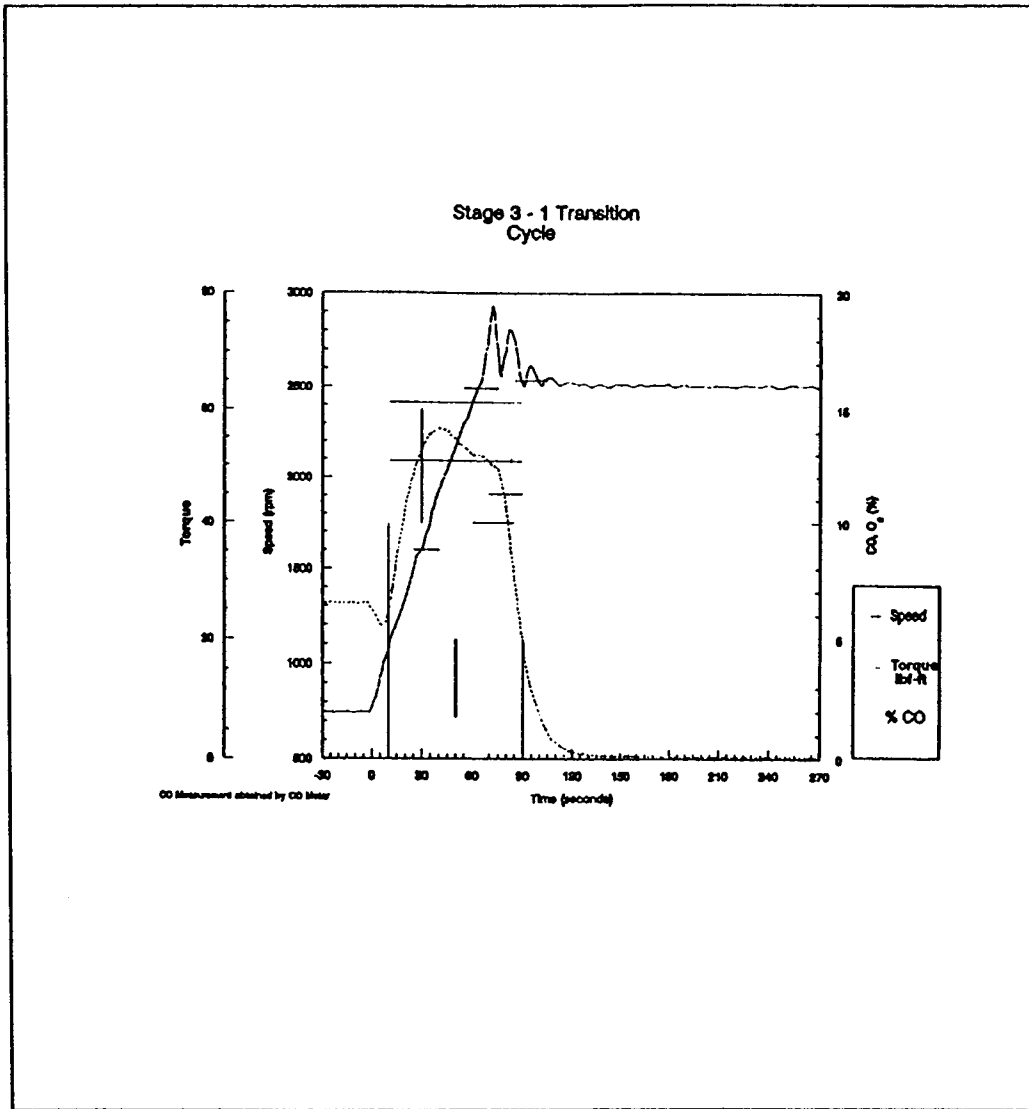

FIG. A7.19 Sequence VE Sample Transition Plot

SEQUENCE VE

Ring Adjustment Summary

Laboratory: LAB	Oil Code: CMIR/OILCODE
Test Number: STAND - RSTRUN/STRUN - RTOTSRUN/TOTSTRUN	Date Completed: RDTCOMP/DTCOMP
Formulation/Stand Code: FORM	

Compression Ring Gap Measurements

Cylinder Number	Top Ring Gap, in.	Second Ring Gap, in.	Top Ring-Land Side Clearance, in.	Second Ring-Land Side Clearance, in.
1	TPRNGGP1	N2RNGGP1	TPRLCLR1	N2RLCLR1
2	TPRNGGP2	N2RNGGP2	TPRLCLR2	N2RLCLR2
3	TPRNGGP3	N2RNGGP3	TPRLCLR3	N2RLCLR3
4	TPRNGGP4	N2RNGGP4	TPRLCLR4	N2RLCLR4

Compression Ring Regap History and Wear Data

Cylinder Number	Ring Location	Ring Gap @ GAPHR, hrs, in.	Ring Gap After Rework, in.	Ring Gap @ GAPHR, hrs, in.	Ring Gap After Rework, in.	Ring Gap Increase Due to Wear, in.
1	Top	TPRGGP1A	TPRGRW1A	TPRGGP1B	TPRGRW1B	TPRGINC1
	Top	TPRGGP2A	TPRGRW2A	TPRGGP2B	TPRGRW2B	TPRGINC2
3	Top	TPRGGP3A	TPRGRW3A	TPRGGP3B	TPRGRW3B	TPRGINC3
4	Top	TPRGGP4A	TPRGRW4A	TPRGGP4B	TPRGRW4B	TPRGINC4

BORE WEAR

POSITION	Wear (mile)	Cylinder Average
Cylinder 1 Top Middle Bottom	BWCYL1T	BWCYL1A
	BWCYL1M	
	BWCYL1B	
Cylinder 2 Top Middle Bottom	BWCYL2T	BWCYL2A
	BWCYL2M	
	BWCYL2B	
Cylinder 3 Top Middle Bottom	BWCYL3T	BWCYL3A
	BWCYL3M	
	BWCYL3B	
Cylinder 4 Top Middle Bottom	BWCYL4T	BWCYL4A
	BWCYL4M	
	BWCYL4B	
Average Bore Wear		CYLBWAVG
Maximum Bore Wear		CYLBWMAX

FIG. A7.20 Ring Adjustment Summary

SEQUENCE VE

SEQUENCE VE DEVIATION PERCENTAGE SUMMARY

Laboratory: LAB	Oil Code: CMIR/OILCODE
Test Number: STAND - RSTRUN/STRUN - RTOTSRUN/TOTSTRUN	Date Completed: RDTCOMP/DTCOMP
Formulation/Stand Code: FORM	

Primary Parameter	Maximum Permitted Deviation Percentage	Calculated Deviation Percentage
Engine Oil Inlet Temperature, °F	2.5%	OILINDP
Engine Coolant Outlet Temperature, °F	2.5%	COLOUTDP
Timing, BTDC	2.5%	TIMNGDP
Exhaust Gas Oxygen (Stages 1 and 2), %	2.5%	EXO212DP
Exhaust Gas CO (Stage 3), %	2.5%	EXCO3DP
Engine Coolant Flow, gal/min	2.5%	COLFLODP
Rocker Arm Cover Inlet Temperature, °F	2.5%	RACINDP
Secondary Parameters		
Engine Speed, r/min	5%	RPMDP
Power, bhp	5%	PWRDP
Rocker Arm Cover Coolant Flow Rate, gal/min	5%	RACCOLDP
Exhaust Backpressure (Stages 1 & 2), in. Hg abs	5%	EXBK12DP

FIG. A7.21 Deviation Percentage Summary

SEQUENCE VE

Mid Limit Operation Specification Summary

Laboratory: LAB	Oil Code: CMIR/OILCODE
Test Number: STAND - RSTRUN/STRUN - RTOTSRUN/TOTSTRUN	Date Completed: RDTCOMP/DTCOMP
Formulation/Stand Code: FORM	

Primary Parameter	Mid Limit Operation Specification Range	Test Average Value
Engine Oil Inlet Temperature, Stage 1 (°F)	155.0 ± 0.5	AENGOIN1
Engine Oil Inlet Temperature, Stage 2 (°F)	210.0 ± 0.5	AENGOIN2
Engine Oil Inlet Temperature, Stage 3 (°F)	115.0 ± 0.5	AENGOIN3
Coolant Outlet Temperature, Stage 1 (°F)	125.0 ± 0.5	ACOLOUT1
Coolant Outlet Temperature, Stage 2 (°F)	185.0 ± 0.5	ACOLOUT2
Coolant Outlet Temperature, Stage 3 (°F)	115.0 ± 0.5	ACOLOUT3
Secondary Parameters		
Engine Speed, Stage 1 (r/min)	2500 ± 5	ARPM1
Engine Speed, Stage 2 (r/min)	2500 ± 5	ARPM2
Engine Speed, Stage 3 (r/min)	750.0 ± 12.5	ARPM3
Power, Stage 1 (bhp)	33.50 ± 0.25	APWR1
Power, Stage 2 (bhp)	33.50 ± 0.25	APWR2
Power, Stage 3 (bhp)	1.00 ± 0.25	APWR3
Rocker Arm Coolant Flow Rate, Stage 1 (gal/min)	2.0 ± 0.1	ARACCFR1
Rocker Arm Coolant Flow Rate, Stage 3 (gal/min)	2.0 ± 0.1	ARACCFR3

FIG. A7.22 Mid Limit Operation Specification Summary

A8. SAFETY PRECAUTIONS

A8.1 General Information

A8.1.1 The operation of this procedure *can* expose personnel to hazardous materials, operations, and equipment. Personnel who are involved in the design, installation, and operation should be thoroughly trained and experienced. Personnel should be provided with safety glasses, hearing protection, and proper tools. All loose clothing should be removed or secured.

A8.1.2 The laboratory facilities should be inspected and approved by the laboratory's safety department. All laboratory areas should be kept clean and free of oil and fuel spills. The laboratory should also be kept free of tripping hazards. Containers of fuel and oil should not be allowed to accumulate excessively. A fixed fire protection system and adequate fire extinguishers should be available in all parts of the laboratory. Emergency showers should be provided throughout the laboratory.

A8.1.3 The test stands should be equipped with a fuel shut-off valve that is designed to automatically interrupt the fuel supply when the engine is not running. The engine should also be automatically shutdown if any of the following events occur: dynamometer loses field current, engine overspeeds, exhaust system fails, room ventilation fails, or the fire protec-

tion system activates. Guards should be installed around all external rotating parts and hot surfaces. All fuel lines, oil lines, steam lines, process water lines, and electrical wiring should be properly routed, protected, and kept in good working order.

A8.1.4 The Sequence VE test exposes personnel to physical hazards and various hazardous chemicals to prepare parts for the test. These chemicals and a summary of specific precautions concerning each chemical are listed as follows. Emergency showers and eye-rinse facilities should be provided in parts preparation areas.

A8.2 Physical Hazards

- A8.2.1 Electrical shock,
- A8.2.2 High-speed rotating equipment,
- A8.2.3 High-temperature surfaces, and
- A8.2.4 Noise.

A8.3 Hazardous Chemicals and Materials

- A8.3.1 *Aliphatic Naphtha (Stoddard Solvent)*:
 - A8.3.1.1 Before opening the container, relieve pressure. Keep the container tightly closed when not in use.
 - A8.3.1.2 Store at moderate temperatures and keep away

from heat, sparks, open flame, oxidizing agents, acids, and bases.

A8.3.1.3 Use dry chemical, foam, or CO₂ as extinguishing media.

A8.3.1.4 In case of spillage, cover with absorbent material and sweep up. Alternatively, flush with water into a retaining area or container.

A8.3.1.5 Use safety glasses and impervious gloves when handling.

A8.3.1.6 Use cartridge or air-line respirators in enclosed areas.

A8.3.1.7 Use only if adequate ventilation is available.

A8.3.1.8 Avoid contact with eyes, skin, and clothing.

A8.3.1.9 Flush eyes with water for 15 min after contact. Wash skin thoroughly with soap and water.

A8.3.2 *Cooling System Cleanser, No. 7 (DuPont Formula-tion)*:

A8.3.2.1 Store at moderate temperatures. Keep container closed until use.

A8.3.2.2 Use water spray, dry chemical, foam, or CO₂ as extinguishing media.

A8.3.2.3 In case of spillage, sweep up. Prevent entry into natural bodies of water.

A8.3.2.4 Use safety glasses and impervious gloves when handling.

A8.3.2.5 Use respiratory protection in absence of proper environmental control.

A8.3.2.6 Use only if adequate ventilation is available.

A8.3.2.7 Avoid contact with eyes, skin, and clothing.

A8.3.2.8 Flush eyes with water for 15 min after contact. Wash skin thoroughly with soap and water.

A8.3.3 *Ethyl Acetate*:

A8.3.3.1 Before opening the container, relieve pressure. Keep the container tightly closed when not in use.

A8.3.3.2 Store at moderate temperatures and keep away from heat, sparks, open flame, oxidizing agents, acids, and bases.

A8.3.3.3 Use dry chemical, foam, or CO₂ as extinguishing media.

A8.3.3.4 In case of spillage, cover with absorbent material and sweep up. Alternatively, flush with water into a retaining area or container.

A8.3.3.5 Use safety glasses and impervious gloves when handling.

A8.3.3.6 Use cartridge or air-line respirators in enclosed areas.

A8.3.3.7 Use only if adequate ventilation is available.

A8.3.3.8 Avoid contact with eyes, skin, and clothing.

A8.3.3.9 Flush eyes with water for 15 min after contact. Wash skin thoroughly with soap and water.

A8.3.4 *Unleaded Gasoline (Phillips J Fuel)*:

A8.3.4.1 Before opening the container, relieve pressure. Keep the container tightly closed when not in use.

A8.3.4.2 Store at moderate temperatures and keep away from heat, sparks, open flame, and oxidizing agents.

A8.3.4.3 Use dry chemical, foam, or CO₂ as extinguishing media.

A8.3.4.4 In case of spillage, cover with absorbent material

and sweep up. Alternatively, flush with water into a retaining area or container.

A8.3.4.5 Use safety glasses and impervious gloves when handling.

A8.3.4.6 Use respiratory hydrocarbon vapor canister in enclosed areas.

A8.3.4.7 Use only if adequate ventilation is available.

A8.3.4.8 Avoid contact with eyes, skin, and clothing.

A8.3.4.9 Flush eyes with water for 15 min after contact. Wash skin thoroughly with soap and water.

A8.3.5 *New and Used Oil Samples*:

A8.3.5.1 Store at moderate temperatures and keep away from extreme heat, sparks, open flame, and oxidizing agents.

(a) (a) Use dry chemical, foam, or CO₂ as extinguishing media.

(b) (b) In case of spillage, cover with absorbent material and sweep up.

(c) (c) Use safety glasses and impervious gloves when handling.

(d) (d) Avoid contact with eyes, skin, and clothing.

(e) (e) Flush eyes with water for 15 min after contact. Wash skin thoroughly with soap and water.

A8.3.5.2 *Used Oil Samples Only*—Since used oils contain compounds that were not originally present in the new oil, follow the most stringent Material Safety Data Sheets guidelines for all components present. (**Warning**—In addition to other precautions, note that continuous contact with used motor oils has caused skin cancer in laboratory mice.)

A8.3.6 *Organic Solvent (Oakite 811)*:

A8.3.6.1 Before opening the container, relieve pressure. Keep the container tightly closed when not in use.

A8.3.6.2 Store at moderate temperatures and keep away from direct sunlight, heat, sparks, open flame, and oxidizing agents.

A8.3.6.3 Use dry chemical, foam, or CO₂ as extinguishing media.

A8.3.6.4 In case of spillage, cover with absorbent material, sweep up, and haul away. Alternatively, flush with water into a retaining area or container.

A8.3.6.5 Use safety glasses and impervious gloves when handling.

A8.3.6.6 Use respiratory hydrocarbon vapor canister in enclosed areas.

A8.3.6.7 Use only if adequate ventilation is available.

A8.3.6.8 Avoid contact with eyes, skin, and clothing.

A8.3.6.9 Flush eyes with water for 15 min after contact. Wash skin thoroughly with soap and water.

A8.3.7 *Organic Solvent (Penetone ECS)*:

A8.3.7.1 Before opening the container, relieve pressure. Keep the container tightly closed when not in use.

A8.3.7.2 Store at moderate temperatures and keep away from heat, sparks, open flame, and strong oxidizing agents.

A8.3.7.3 Use dry chemical, foam, or CO₂ as extinguishing media.

A8.3.7.4 In case of spillage, cover with absorbent material, and sweep up. Dispose in accordance with RCRA procedures.

A8.3.7.5 Use safety glasses and impervious gloves when handling.

A8.3.7.6 Use respiratory hydrocarbon vapor canister in enclosed areas.

A8.3.7.7 Use only if adequate ventilation is available.

A8.3.7.8 Avoid contact with eyes, skin, and clothing.

A8.3.7.9 Flush eyes with water for 15 min after contact.

Wash skin thoroughly with soap and water.

A8.3.8 *n*-Pentane:

A8.3.8.1 Before opening the container, relieve pressure. Keep the container tightly closed when not in use.

A8.3.8.2 Store at moderate temperatures and keep away from heat, sparks, and open flame.

A8.3.8.3 Use dry chemical, foam, or CO₂ as extinguishing media.

A8.3.8.4 In case of spillage, cover with absorbent material, sweep up, and haul away.

A8.3.8.5 Use safety glasses and impervious gloves when handling.

A8.3.8.6 Use respiratory hydrocarbon vapor canister in enclosed areas.

A8.3.8.7 Use only if adequate ventilation is available.

A8.3.8.8 Avoid contact with eyes, skin, and clothing.

A8.3.8.9 Flush eyes with water for 15 min after contact. Wash skin thoroughly with soap and water.

A9. AUTOMATIC DATA ACQUISITION

A9.1 Three levels of performance for data acquisition systems have been outline by the Data Acquisition Task Force. Guidelines for the three systems are outlined as follows. Additional information concerning data acquisition systems can be found in 2.6.

A9.2 *Manual*—Manual systems may utilize hand logging of operating data or automatic recording of one or more measured parameters. These systems record data only at the intervals prescribed by the procedure. Reports generated from manual systems should be formatted as prescribed by the procedure.

A9.3 *Enhanced*—Some or all of the data is recorded at a higher frequency than is prescribed by the procedure. Enhanced systems usually utilize automatic data acquisition and

utilize some technique to reduce the volume of data reported, that is, averaging. Reports generated from enhanced systems should be formatted as prescribed in the procedure. However, a statement is added that defines data that is enhanced and the method used for enhancement.

A9.4 *Automated*—Alarms for parameter excursions must be at a frequency compatible with process control requirements. The frequency of data recording must be compatible with sound engineering and statistical practice for trend analysis and review of operation. The reporting capability must be consistent with data user requirements, including reporting out-of-limit data. The system must be capable of accepting manual entry of data not available from full-time sensors in a data base that is common with the other data.

A10. OAKITE 811 MONITORING PROGRAM

A10.1 If the laboratory utilizes Oakite 811, the level of butyl cellosolve must be monitored on a weekly basis. The Oakite 811 should be replaced when the butyl cellosolve content falls below 5 % by volume.

A10.2 Two test methods have been found to be effective to determine the level of butyl cellosolve: determination by capillary column gas chromatography (GC) and determination by GC. The two test methods are detailed as follows:

A10.3 *Determination of Butyl Cellosolve Content by Capillary Column GC:*

A10.3.1 *Scope*—This test method utilizes a fused capillary column GC method.

A10.3.2 *Summary of Test Method*—Samples of Oakite 811 are injected using the split injection mode on a crosslinked, 5 % phenylmethyl silicone-fused silica column. An internal standard is added to each sample prior to injection. Percent volume butyl cellosolve is determined by standard addition.

A10.3.3 *Significance*— If the butyl cellosolve level of Oakite 811 falls below 5 % by volume, a gel-like substance forms on parts when they are rinsed with water. The cleaning

solution should be replaced when this occurs.

A10.3.4 *Apparatus:*

A10.3.4.1 *Gas Chromatograph*—The gas chromatograph should be equipped with a flame ionization detector (FID). The capillary must have an inlet and detector system designed for fused-silica capillary chromatography. The recorder must have a range from 0 to 1 mV and a response time of 1 s or less.

A10.3.4.2 *Data Analysis System*—The data analysis system must provide a means to perform peak integration.

A10.3.4.3 *Column*—The column must be a crosslinked, 5 % phenylmethyl silicone-fused silica column. The dimensions of the column are 25 m by 0.32 mm.

A10.3.4.4 *Syringe*—All syringes must be a 10-L syringe graduated in 0.1-L increments.

A10.3.5 *Conditions of Analysis:*

A10.3.5.1 *Temperatures*— Sample inlet system is 250°C; detector is 320°C; initial column temperature is 40°C; and final column temperature is 300°C.

A10.3.5.2 *Temperature Change Rate*, 4°C/min for 15 min; 14°C/min after 15 min.

A10.3.5.3 *Total Time for Temperature Change*, 20 min (variable).

A10.3.5.4 *Electrometer Attenuation*, 32/range 10^{-11} .

A10.3.5.5 *Column Head Pressure*, 5 psig (34 kPa).

A10.3.5.6 *Injection Mode*, split.

A10.3.5.7 *Inlet Split Vent Flow Rate*, 480 mL/min.

A10.3.5.8 *Column Makeup Gas Flow Rate*, 30 mL/min.

A10.3.5.9 *Recorder Chart Speed*, 1 cm/min.

A10.3.6 *Reagents and Materials*:

A10.3.6.1 *Gases*—Helium (carrier gas), regular grade $\geq 99.995\%$ pure; hydrogen (detector gas), prepurified; and air (detector gas), breathing grade.

A10.3.6.2 *Solvents*—Methanol, HPLC grade; hexonal, HPLC grade; and butyl cellosolve, $\geq 99\%$ pure.

A10.3.7 *Preparation of Standards and Samples*:

A10.3.7.1 *Preparation of Standards*—Standards are prepared using the standard addition technique. Prepare a stock solution of 20% butyl cellosolve by volume in Oakite 811. From the stock solution, prepare the following solutions in 10-mL flasks: (a) 5-mL stock solution + 5 mL Oakite 811 = 10%, (b) 2-mL stock solution + 8 mL Oakite 811 = 4%, and (c) 7-mL stock solution + 3 mL Oakite 811 = 14%. Pipette 10 mL of the stock solution into each of the 10-mL flasks and fill the flasks to the 10-mL mark with Oakite 811. Add 1 mL of hexonal into three additional 10-mL flasks that are labeled a-I, b-I, and c-I. Hexonal is a slightly viscous liquid. When dispensing it with a pipette, a thin film of liquid can be seen trailing the slug of the solvent. This film should travel to the tip of the pipette approximately 1 min before the pipette is removed from the flask. Withdraw 9 mL of the standard solution from flasks a, b, and c, and dispense into the respective 10-mL flasks containing hexonal. Cap the flasks, mix well, and seal the flasks with parafilm until ready for use.

A10.3.7.2 *Preparation of Samples*—Add 1 mL of hexonal to a labeled 10-mL flask for each sample to be analyzed. Fill each flask to the 10-mL mark with a sample. Cap the flasks, mix well, and seal the flasks with parafilm until ready for use. Prepare all samples and standards in a 9:1 ratio:sample:internal standard or standard:internal standard.

A10.3.8 *Procedure*:

A10.3.8.1 Prepare the gas chromatograph for the operating conditions stated in 6.1.2.

A10.3.8.2 *Sample Injection Technique*—A solvent flush method is utilized. Draw methanol into the syringe to the 0.5-L mark. Raise the methanol slug to the 3-L mark. Draw the analysis sample to the 1-L mark in one continuous motion. Raise the sample slug to the 3-L mark to produce a slug of air in the syringe needle and lower barrel. Inject the sample and hold the syringe in the injection port for 5 s before removing it.

A10.3.8.3 *Start the gas chromatograph and all recording devices*.

A10.3.8.4 Complete the analysis in accordance with the temperature change specifications shown in A10.2.5.2 and A10.2.5.3.

A10.3.9 *Calculation*:

A10.3.9.1 *Calibration Data*—Determine the peak area ratio for each standard in accordance with the following equation:

$$\frac{\text{area of butyl cellosolve in } V}{\text{area of hexonal}} = W \quad (\text{A10.1})$$

where:

V = Oakite 811 blend used to make up the standard blends, and

S = $W \times$ % volume of Oakite 811 in the standard blend.

Example—A 14% butyl cellosolve standard solution made up in Oakite 811 would be 86% Oakite 811; $W \times 0.86 = S$. The actual peak area ratio of standard is calculated using the following formula:

$$\frac{\text{area of butyl cellosolve in } V}{\text{area of hexonal}} - S \quad (\text{A10.2})$$

where:

S = $W \times$ % volume of Oakite 811 in the standard blend.

Example—A 14% butyl cellosolve standard solution made up in Oakite 811 would be 86% Oakite 811; $W \times 0.86 = S$.

where:

X = total area of butyl cellosolve in the sample to be quantitated.

A10.3.9.2 *Percent Volume Butyl Cellosolve*—The data from the following calibration curve is used to determine the percent volume butyl cellosolve in the sample after the actual peak area ratio is calculated for the sample. The correlation coefficient of the data is 0.99998:

Actual Peak Area Ratio	% Volume
0.267	4
0.690	10
0.996	14

A10.3.10 *Comments*—The injection port liner becomes contaminated after a series of analyses and should be used prior to use in another analytical project.

A10.4 *Determination of Butyl Cellosolve Content by Gas Chromatography*:

A10.4.1 *Scope*—This test method utilizes gas chromatography to determine the volume percentage of butyl cellosolve in Oakite 811 cleaning compound.

A10.4.2 *Summary of Test Method*—The percent volume of butyl cellosolve in Oakite 811 is determined by the technique of standard addition using gas chromatography.

A10.4.3 *Significance and Use*—If the butyl cellosolve level of Oakite 811 falls below 5% by volume, a gel-like substance forms on parts when they are rinsed with water. The cleaning solution should be replaced when this occurs.

A10.4.4 *Apparatus*:

A10.4.4.1 *Gas Chromatograph*—The gas chromatograph should be equipped with a thermal conductivity detector (the suitability of a FID has not been determined). The recording potentiometer must have a full-scale response time of 1 s or less.

A10.4.4.2 *Data Analysis System*—The data analysis system must provide a means to perform area integration.

A10.4.4.3 *Column*—The column must be a OV-101 stationary phase with 10% on 100/200 and Gas Chrom Q packing. The dimensions of the column are 6-ft by 0.125-in. (1.83-m by 3.18-mm) outside diameter.

A10.4.4.4 *Syringe*—All syringes must be a 10-L syringe

graduated in 0.1-L increments.

A10.4.4.5 *Flow Controllers*—The gas chromatograph must be equipped with constant flow controllers.

A10.4.5 *Reagents and Materials*:

A10.4.5.1 *Helium (Carrier Gas)*, zero grade.

A10.4.5.2 *Butyl Cellosolve*, purity $\geq 99\%$.

A10.4.6 *Preparation of Sample*—Prepare four solutions containing 10, 15, 20, and 25 % volume butyl cellosolve in Oakite 811. Mix the solutions thoroughly for 2 min.

A10.4.7 *Procedure*:

A10.4.7.1 Set the injection port temperature to 300°C. Adjust the flow rate to 40 mL/min. Set the detector temperature to 350°C. Adjust the oven temperature to 80°C. Inject exactly 5 L of sample.

A10.4.7.2 Turn on the chart recorder and integrator immediately after sample injection. Maximize the butyl cellosolve peak area of the sample containing the highest level of butyl cellosolve. Do not adjust the sensitivity for subsequent samples.

A10.4.7.3 After the butyl cellosolve peak has eluded (approximately 5 min), rapidly raise the oven temperature to 300°C to elute the high boiling components of the sample. When the baseline returns to its initial level, lower the oven temperature to 80°C.

A10.4.7.4 Record the butyl cellosolve peak areas for all four samples.

A10.4.8 *Interpretation of Results*—Plot the area of the butyl cellosolve peaks versus the percent volume of the butyl cellosolve added to the Oakite 811. The negative of the *X*-axis intercept is the value of the volume percentage of butyl cellosolve in the Oakite 811. The negative of the *X*-axis intercept can also be determined by least squares analysis.

A10.4.9 *Precision*:

A10.4.9.1 *Repeatability*—The difference between successive test results obtained by the same operator with the same apparatus under constant operating conditions on identical test material should not exceed $\pm 0.3\%$ volume in one case out of twenty.

A11. TEST PRECISION—REFERENCE OILS

NOTE A11.1—This is for operationally valid tests through June 30, 1991.

A11.1 *Repeatability (r)* in Table A11.1 is the difference between successive results obtained on the same test oil by the same operators on the same test stand, and would, in the long run, in the normal and correct conduct of the test method, exceed the values shown in only one case in twenty. It should be noted that these successive tests are not run in the same engines; that is, each engine is completely rebuilt before each test, and the engine is believed to be an important variable affecting the precision of the test.

A11.2 *Reproducibility (R)* is as defined previously in 16.1.1.3.

A11.3 In Table A11.1, *X* is the average value of two or more tests on the same oil.

A11.4 The reference oil test operating conditions are more carefully scrutinized than those for the candidate oil tests, and a significantly higher percentage of reference oil tests are rejected as a result. This could represent a source of bias

TABLE A11.1 Reference Oil Precision Statistics^A

Variable	Measured Units			
	Repeatability ^B		Reproducibility ^C	
	s_r^D	r^E	s_R^D	R^E
Average Engine Varnish, merits	0.26	0.73	0.28	0.78
Average Piston Varnish, merits	0.25	0.70	0.24	0.67
Variable	Transformed Units			
	Repeatability ^B		Reproducibility ^C	
	s_r^D	r^E	s_R^D	R^E
Average Engine Sludge, $-\ln(9.65\text{-merits})$	0.48	1.34	0.48	1.34
Rocker Cover Sludge, $-\ln(9.65\text{-merits})$	0.50	1.40	0.52	1.46
Average Cam Wear, $\sqrt{(\text{mils})}$	0.56	1.57	0.56	1.57
Maximum Cam Wear, $\sqrt{(\text{mils})}$	0.83	2.32	0.83	2.32

^A These statistics are based on results obtained on Test Monitoring Center Reference Oils 926-1, 925-2, 927-1, 925, and 1002 over the period from April 1992 through September 1994.

^B Repeatability values refer to tests run on the same oil in the same laboratory.

^C Reproducibility values refer to tests run on the same oil in different laboratories.

^D s = Standard deviation.

^E On the basis of test error alone, the difference, in absolute value, between two test results will be expected to exceed this value about 5 % of the time. This value is obtained by multiplying the standard deviation by 2.8.

between the two precision estimates.

A12. CONTROL CHART TECHNIQUE FOR SEVERITY ADJUSTMENT (SA)

A12.1 *Average Engine Sludge (AES) SA*—An EWMA technique is applied to standardized calibration test AES results. Results are converted to transformed units by the formula $-1 \times (\ln(9.65 - AES))$. Transformed values are standardized using delta/s (Δ/s) ((result - target)/standard deviation). The targets and standard deviations for current reference oils are published by the ASTM TMC.

A12.1.1 Include all operationally valid reference tests in a laboratory control chart. Chart tests in order of completion date and time. A minimum of two tests is required to initialize a control chart. Calculate EWMA values using Eq A12.1.

$$Z_i = 0.2(Y_i) + 0.8(Z_{i-1}) \quad (\text{A12.1})$$

where:

$Z_0 = 0$ and Y_i = standardized test result, and

Z_i = EWMA of the standardized test result at test order i .

If the absolute value of the EWMA, rounded to three places after the decimal, exceeds 0.653, then apply an SA to subsequent non-reference results. The following example illustrates the application of Eq A12.1 for determining the application of AES SA.

$$Z_1 = 0.694 \text{ and } Y_2 = 1.247 \quad (\text{A12.2})$$

$$\text{EWMA} = 0.2(1.247) + 0.8(0.694) = 0.805$$

A12.1.2 Since $|0.805| > 0.653$, an SA must be applied. Multiply 0.805 by the AES standard deviation for oil 926-1. Multiply this value by -1 and round to three places after the decimal. Record this value on the test results summary of the test report in the space for AES applied SA. Add this value to the transformed non-reference result. Multiply this sum by -1 . Find the antilog. Subtract the antilog from 9.65 and round to two places after the decimal. Enter this number on the test results summary of the test report in the space for the AES Final Result. An SA will remain in effect until the next reference test. At that time, calculate a new EWMA.

A12.2 *Rocker Arm Cover Sludge (RACS) SA*—An EWMA technique is applied to standardized calibration test RACS results. Results are converted to transformed units by the formula $-1 \times (\ln(9.65 - RACS))$. Transformed values are standardized using delta/s (Δ/s) ((result - target)/standard deviation). The targets and standard deviations for current reference oils are published by the ASTM TMC.

A12.2.1 Include all operationally valid reference tests in a laboratory control chart. Chart tests in order of completion date and time. A minimum of two tests is required to initialize a control chart. Calculate EWMA values using Eq A12.1. If the absolute value of the EWMA, rounded to three places after the decimal, exceeds 0.653, then apply an SA to subsequent non-reference results. The following example illustrates the use of Eq A12.1 for determining the application of a RACS SA.

$$Z_1 = 0.570 \text{ and } Y_2 = 1.195 \quad (\text{A12.3})$$

$$\text{EWMA} = 0.2(1.195) + 0.8(0.570) = 0.695$$

A12.2.2 Since $|0.695| > 0.653$, an SA must be applied.

Multiply 0.695 by the RACS standard deviation for oil 926-1. Multiply this number by -1 and round to three places after the decimal. Record this value on the test results summary page of the test report in the space for RACS applied SA. Add this value to the transformed non-reference result. Multiply this sum by -1 . Find the antilog. Subtract the antilog from 9.65 and round to two places after the decimal. Enter this number in the RACS final result space on the test results summary page of the test report. An SA will remain in effect until the next reference test. At that time, calculate a new EWMA.

A12.3 *Average Engine Varnish (AEV) SA*—An EWMA technique is applied to standardized calibration test AEV results. For reference tests starting after January 15, 1992, and before May 1, 1993, adjust each average engine varnish result by adding 0.18 to the AEV rating. Enter the corrected rating in the corrected results space in the final test report for tests completed after May 1, 1993. Values are standardized using delta/s (Δ/s) ((result - target)/standard deviation). The targets and standard deviations for current reference oils are published by the ASTM TMC.

A12.3.1 Include all operationally valid reference tests in a laboratory control chart. Chart tests in order of completion date and time. A minimum of two tests is required to initialize a control chart. Calculate EWMA values using A12.1. If the absolute value of the EWMA, rounded to three places after the decimal, exceeds 0.653, then apply an SA to subsequent non-reference results. The following example illustrates the use of Eq A12.1 for determining the application of an AEV SA.

$$Z_1 = -0.572 \text{ and } Y_2 = 1.469 \quad (\text{A12.4})$$

$$\text{EWMA} = 0.2(-1.469) + 0.8(-0.572) = -0.751$$

A12.3.2 Since $| -0.751 | > 0.653$, an SA must be applied. Multiply -0.751 by the AEV standard deviation for oil 926-1. Multiply this value by -1 and round to three places after the decimal. Record this value on the test results summary of the test report in the space for AEV applied SA. Add this value to the non-reference result. Enter this number in the AEV final result space on the test results summary page of the test report. An SA will remain in effect until the next reference test. At that time, calculate a new EWMA.

A12.4 *Piston Skirt Varnish (PSV) SA*—An EWMA technique is applied to standardized calibration test PSV results. For reference tests started after March 15, 1992, and before May 1, 1992, add 0.15 to the reported PSV result. Enter the corrected rating in the corrected results space in the final test report for tests completed after May 1, 1993. Values are standardized using delta/s (Δ/s) ((result - target)/standard deviation). The targets and standard deviations for current reference oils are published by the ASTM TMC.

A12.4.1 Include all operationally valid reference tests in a laboratory control chart. Chart tests in order of completion date and time. A minimum of two tests is required to initialize a control chart. Calculate EWMA values using Eq A12.1. If the absolute value of the EWMA, rounded to three places after the

decimal, exceeds 0.653, then apply an SA to subsequent non-reference results. The following example illustrates the use of Eq A12.1 for determining the application of a PSV SA.

$$Z_1 = 0.667 \text{ and } Y_2 = -1.062 \quad (\text{A12.5})$$

$$\text{EWMA} = 0.2 (1.062) + 0.8 (0.667) = 0.746$$

A12.4.2 Since $|0.746| > 0.653$, an SA must be applied. Multiply 0.746 by the PSV standard deviation for oil 926-1. Multiply this value by -1 and round to three places after the decimal. Record this value on the test results summary of the test report in the space for PSV applied SA. Add this value to the non-reference result. Enter this number in the PSV final result space on the test results summary page of the test report. An SA will remain in effect until the next reference test. At that time, calculate a new EWMA.

A12.5 *Average Cam Wear (ACW) SA*—Apply an EWMA technique to standardized calibration test ACW results. Convert tests completed prior to March 10, 1997, to micrometres by multiplying the result by 25.4. Convert results to transformed units by taking the square root of the ACW result. Add 1.451 to transformed reference oil test results completed after August 31, 1995, and before May 16, 1996. Standardize values using delta/s (Δ/s) ((result – target)/standard deviation). The targets and standard deviations for current reference oils are published by the ASTM TMC.

A12.5.1 Include all operationally valid reference tests in a laboratory control chart. Chart tests in order of completion date and time. A minimum of two tests is required to initialize a control chart. Calculate EWMA values using Eq A12.1. If the absolute value of the EWMA, rounded to three places after the decimal, exceeds 0.653, then apply an SA to subsequent non-reference results. The following example illustrates the use of Eq A12.1 for determining the application of an ACW SA.

$$Z_1 = -0.541 \text{ and } Y_2 = -1.197 \quad (\text{A12.6})$$

$$\text{EWMA} = 0.2 (-1.197) + 0.8 (-0.541) = -0.672$$

A12.5.2 Since $| - 0.672 | > 0.653$, an SA must be applied. Multiply -0.672 by the ACW standard deviation for oil 926-1. Multiply this value by -1 and round to three places after the decimal. Record this value on the test results summary of the test report in the space for ACW applied SA. Add this value to the transformed non-reference result. If the adjusted trans-

formed non-reference result is less than zero, enter zero. Otherwise, square the result and round to two places after the decimal. Enter this number in the ACW final result space on the test results summary page of the test report. An SA will remain in effect until the next reference test. At that time, calculate a new EWMA.

A12.6 *Maximum Cam Wear (MCW) SA*—Apply an EWMA technique to standardized calibration test MCW results. Convert tests completed prior to March 10, 1997, to micrometres by multiplying the result by 25.4. Convert results to transformed units by taking the square root of the MCW result. Add 1.693 to transformed reference oil test results completed after August 31, 1995, and before May 16, 1996. Standardize transformed values using delta/s (Δ/s) ((result – target)/standard deviation). The targets and standard deviations for current reference oils are published by the ASTM TMC.

A12.6.1 Include all operationally valid reference tests in a laboratory control chart. Chart tests in order of completion date and time. A minimum of two tests is required to initialize a control chart. Calculate EWMA values using Eq A12.7.

$$Z_i = 0.2 (Y_i) + 0.8 (Z_{i-1}) \quad (\text{A12.7})$$

where:

$$Z_0 = 0$$

Y_i = standardized test result, and

Z_i = EWMA of the standardized test result at test order i .

If the absolute value of the EWMA, rounded to three places after the decimal, exceeds 0.653, then apply an SA to subsequent non-reference results. The following example illustrates this process:

$$Z_1 = 0.634 \text{ and } Y_2 = 1.369 \quad (\text{A12.8})$$

$$\text{EWMA} = 0.2 (1.369) + 0.8 (0.634) = 0.781$$

A12.6.2 Since $| - 0.781 | > 0.653$, an SA must be applied. Multiply 0.781 by the MCW standard deviation for oil 926-1. Multiply this value by -1 and round to three places after the decimal. Record this value on the Test Results Summary of the test report in the space for MCW Applied SA. Add this value to the transformed non-reference result. Square result and round to one place after the decimal. Enter this number in the MCW Final Result space on the Test Results Summary page of the test report. An SA will remain in effect until the next reference test. At that time, calculate a new EWMA.

A13. STATISTICAL EQUATIONS FOR MEAN AND STANDARD DEVIATION

A13.1 See Eq A13.1 and Eq A13.2 for mean and standard deviation.

$$\text{mean} = \frac{1}{n} \sum_{i=1}^n [Y_i (\text{standard}) - Z_i (\text{reading})] \quad (\text{A13.1})$$

$$\text{standard deviation} = \sqrt{\frac{\sum_{i=1}^n [(Y_i - Z_i) - \text{mean}]^2}{df}} \quad (\text{A13.2})$$

where:

n = total number of data pairs, and

df = degrees of freedom = $n-1$.

A14. DATA DICTIONARY

A14.1 Figs. A14.1-A14.13 is the Data Dictionary, Figs. A14.14 and A14.15 is the Repeating Field Specifications, and Fig. A14.16 is the Header Data Dictionary

2-sep-1997

Data Dictionary

<u>Sequence</u>	<u>Form</u>	<u>Test Area</u>	<u>Field Name</u>	<u>Field Length</u>	<u>Decimal Size</u>	<u>Data Type</u>	<u>Units/Format</u>	<u>Description</u>
10	1	VE	VERSION	8	0	C	YYYYMMDD	VE VERSION 19970902
20	1	VE	TSTSPON1	40	0	C		TEST PURCHASER, FIRST LINE
30	1	VE	TSTSPON2	40	0	C		TEST PURCHASER, SECOND LINE
40	1	VE	LABVALID	1	0	C	V, I OR N	TEST LAB VALIDATION (V, I OR N)
50	1	VE	STAND	5	0	C		STAND
60	1	VE	RSTRUN	4	0	C		REFERENCE STAND RUN
70	1	VE	STRUN	4	0	C		RUNS BETWEEN CALIBRATION TESTS
80	1	VE	RTOTSRUN	5	0	C		REFERENCE TOTAL RUNS ON STAND
90	1	VE	TOTSTRUN	5	0	C		TOTAL RUNS-TEST STAND
100	1	VE	RDTCOMP	8	0	C	YYYYMMDD	REFERENCE DATE COMPLETED (YYYYMMDD)
110	1	VE	DTCOMP	8	0	C	YYYYMMDD	DATE COMPLETED (YYYYMMDD)
120	1	VE	REOTTIME	5	0	C	HH:MM	REFERENCE END OF TEST TIME (HH:MM)
130	1	VE	EOTTIME	5	0	C	HH:MM	TIME COMPLETED (HH:MM)
140	1	VE	OILCODE	38	0	C		NON REFERENCE OIL CODE
150	1	VE	CMIR	6	0	C		CMIR
160	1	VE	FORM	38	0	C		FORMULATION/STAND CODE
170	1	VE	ALTCODE1	10	0	C		ALTERNATE OIL CODE 1
180	1	VE	ALTCODE2	10	0	C		ALTERNATE OIL CODE 2
190	1	VE	ALTCODE3	10	0	C		ALTERNATE OIL CODE 3
200	1	VE	OPVALID	8	0	C	HAS/HAS NOT	OPERATIONAL VALIDITY STATEMENT (HAS/HAS NOT)
210	1	VE	SUBLAB	40	0	C		SUBMITTED BY: TESTING LABORATORY
220	1	VE	SUBSIGIM	70	0	C		SUBMITTED BY: SIGNATURE IMAGE
230	1	VE	SUBNAME	40	0	C		SUBMITTED BY: SIGNATURE TYPED NAME
240	1	VE	SUBTITLE	40	0	C		SUBMITTED BY: TITLE
250	2	VE	LAB	2	0	C		LAB CODE
260	2	VE	SAEVISC	7	0	C		SAE VISCOSITY GRADE
270	2	VE	IND	6	0	C		TNC OIL CODE
280	2	VE	TESTLEN	3	0	Z	HHH	TEST LENGTH (HHH)
290	2	VE	ENGINE	6	0	C		NON-REFERENCE ENGINE
300	2	VE	NOMPISOV	4	2	N		NOMINAL PISTON OVERSIZE
310	2	VE	FUELBTD	2	0	C		FUEL BATCH IDENTIFIER
320	2	VE	DTSTRT	8	0	C	YYYYMMDD	START DATE (YYYYMMDD)
330	2	VE	STRTTIME	5	0	C	HH:MM	START TIME (HH:MM)
340	2	VE	LABOCODE	12	0	C		LABORATORY INTERNAL OIL CODE
350	2	VE	RACSRT	5	2	N	MERITS	ROCKER ARM COVER SLUDGE RATING (MERITS)
360	2	VE	TRANRACS	6	3	N	TRANS UNITS	TRANSFORMED RACS RESULTS (TRANS UNITS)
370	2	VE	RACCF	6	3	N	TRANS UNITS	ROCKER ARM COVER SLUDGE CORRECTION FACTOR (TRANS UNITS)
380	2	VE	TRACSCOR	6	3	N	MERITS	ROCKER COVER SLUDGE CORRECTED RATING - TRANSFORMED (MERITS)
390	2	VE	RACSSA	6	3	N	TRANS UNITS	ROCKER ARM COVER SLUDGE -APPLIED SA (TRANS UNITS)
400	2	VE	TRACSFNL	6	3	N	TRANS UNITS	TRANSFORMED RACS FINAL RESULTS (TRANS UNITS)
410	2	VE	RACSFNL	5	2	N	MERITS	ROCKER ARM COVER SLUDGE FINAL RESULT (MERITS)
420	2	VE	CAMBSRT	5	2	N	MERITS	CAMSHAFT BAFFLE SLUDGE RATING (MERITS)
430	2	VE	VLVDCRRT	5	2	N	MERITS	VALVE DECK SLUDGE RATING (MERITS)
440	2	VE	FSLHSGRT	5	2	N	MERITS	FRONT SEAL HOUSING SLUDGE RATING (MERITS)
450	2	VE	CYLBLKRT	5	2	N	MERITS	CYLINDER BLOCK SLUDGE RATING (MERITS)
460	2	VE	OILPNSRT	5	2	N	MERITS	OIL PAN SLUDGE RATING (MERITS)
470	2	VE	AES	5	2	N	MERITS	AVG ENGINE SLUDGE RATING (MERITS)
480	2	VE	TRANAES	6	3	N	TRANS UNITS	TRANSFORMED AES RESULTS (TRANS UNITS)
490	2	VE	AESCF	6	3	N	TRANS UNITS	AVG ENGINE SLUDGE CORRECTION FACTOR (TRANS UNITS)
500	2	VE	TAESCOR	6	3	N	MERITS	AVG ENGINE SLUDGE CORRECTED RATING - TRANSFORMED (MERITS)
510	2	VE	AESSA	6	3	N	TRANS UNITS	AVG ENGINE SLUDGE -APPLIED SA (TRANS UNITS)
520	2	VE	TAESFNL	6	3	N	TRANS UNITS	TRANSFORMED AES FINAL RESULTS (TRANS UNITS)
530	2	VE	AESFNL	5	2	N	MERITS	AVG ENGINE SLUDGE FINAL RESULT (MERITS)

FIG. A14.1 Data Dictionary

2-sep-1997

Report: ASTM Data Dictionary

Sequence	Form	Test Area	Field Name	Field Decimal Data			Units/Format	Description
				Length	Size	Type		
540	2	VE	PISKVRT	5	2	N	MERITS	PISTON SKIRTS VARNISH RATING (MERITS)
550	2	VE	PISKVCF	6	3	N	MERITS	PISTON SKIRTS VARNISH CORRECTION FACTOR (MERITS)
560	2	VE	PSVSA	6	3	N	MERITS	PISTON SKIRT VARNISH -APPLIED SA (MERITS)
570	2	VE	PISKVFNL	5	2	N	MERITS	PISTON SKIRTS VARNISH FINAL RESULT (MERITS)
580	2	VE	RACVRT	5	2	N	MERITS	ROCKER ARM COVER VARNISH RATING (MERITS)
590	2	VE	CAMBFVRT	5	2	N	MERITS	CAMSHAFT BAFFLE VARNISH RATING (MERITS)
600	2	VE	CYLWLVRT	5	2	N	MERITS	CYLINDER WALLS VARNISH RATING (MERITS)
610	2	VE	OILPNVRT	5	2	N	MERITS	OIL PAN VARNISH RATING (MERITS)
620	2	VE	AEV	5	2	N	MERITS	AVG ENGINE VARNISH RATING (MERITS)
630	2	VE	AEVCF	6	3	N	MERITS	AVG ENGINE VARNISH CORRECTION FACTOR (MERITS)
640	2	VE	AEVSA	6	3	N	MERITS	AVG ENGINE VARNISH -APPLIED SA (MERITS)
650	2	VE	AEVFNL	5	2	N	MERITS	AVG ENGINE VARNISH FINAL RESULT (MERITS)
660	2	VE	ACW	6	1	N	MICROMETERS	AVG CAMSHAFT WEAR (MICROMETERS)
670	2	VE	TRANACW	6	3	N	TRANS UNITS	TRANSFORMED ACW RESULTS (TRANS UNITS)
680	2	VE	ACWCF	6	3	N	TRANS UNITS	AVG CAMSHAFT WEAR CORRECTION FACTOR (TRANS UNITS)
690	2	VE	TACWCOR	6	3	N	TRANS UNITS	AVG CAMSHAFT WEAR CORRECTED RATING - TRANSFORMED (TRANS UNIT
700	2	VE	ACWSA	6	3	N	TRANS UNITS	AVG CAM WEAR -APPLIED SA (TRANS UNITS)
710	2	VE	TACWFNL	6	3	N	TRANS UNITS	TRANSFORMED ACW FINAL RESULTS (TRANS UNITS)
720	2	VE	ACWFNL	6	1	N	MICROMETERS	AVG CAMSHAFT WEAR FINAL RESULT (MICROMETERS)
730	2	VE	MCW	6	0	N	MICROMETERS	MAX CAMSHAFT WEAR (MICROMETERS)
740	2	VE	TRANMCW	6	3	N	TRANS UNITS	TRANSFORMED MCW RESULTS (TRANS UNITS)
750	2	VE	MCWCF	6	3	N	TRANS UNITS	MAX CAMSHAFT WEAR CORRECTION FACTOR (TRANS UNITS)
760	2	VE	TMCWCOR	6	3	N	TRANS UNITS	MAX CAMSHAFT WEAR CORRECTED RATING - TRANSFORMED (TRANS UNIT
770	2	VE	MCWSA	6	3	N	TRANS UNITS	MAX CAM WEAR -APPLIED SA (TRANS UNITS)
780	2	VE	TMCWFNL	6	3	N	TRANS UNITS	TRANSFORMED MCW FINAL RESULTS (TRANS UNITS)
790	2	VE	MCWFNL	6	0	N	MICROMETERS	MAX CAMSHAFT WEAR FINAL RESULT (MICROMETERS)
800	2	VE	ARAW	6	1	N	MG	AVG ROCKER ARM WEAR (MG)
810	2	VE	MAXRAW	6	1	N	MG	MAX ROCKER ARM WEAR (MG)
820	2	VE	ATRGINC	5	1	N	MILS	AVG TOP RING GAP INCREASE WEAR (MILS)
830	2	VE	MXTRGINC	5	1	N	MILS	MAX TOP RING GAP INCREASE WEAR (MILS)
840	2	VE	ARBWL	6	1	N	MG	AVG ROD BEARING WEIGHT LOSS WEAR (MG)
850	2	VE	MAXBWL	6	1	N	MG	MAX ROD BEARING WEIGHT LOSS WEAR (MG)
860	2	VE	OSCRNSLG	4	0	N	% AREA	OIL SCREEN SLUDGE CLOGGING (% AREA)
870	2	VE	OSCRNDEB	4	0	N	% AREA	OIL SCREEN DEBRIS CLOGGING (% AREA)
880	2	VE	OILRING	4	0	N	% AREA	OIL RING CLOGGING (% AREA)
890	2	VE	PCV18	4	0	N	% AREA	PCV VALVE AT 18 IN. HG. CLOGGING (% AREA)
900	2	VE	PCV8	4	0	N	% AREA	PCV VALVE AT 8 IN. HG. CLOGGING (% AREA)
910	2	VE	NOCAMLOB	1	0	N		NUMBER OF CAMSHAFT LOBE HOLES
920	2	VE	AVGCLD	5	2	N	MERITS	AVERAGE CROWN LAND DEPOSITS (MERITS)
930	2	VE	AVGSLD	5	2	N	MERITS	AVERAGE SECOND LAND DEPOSITS (MERITS)
940	2	VE	AVGORLD	5	2	N	MERITS	AVERAGE OIL RING LAND DEPOSITS (MERITS)
950	2	VE	AVGPUCD	5	2	N	MERITS	AVERAGE PISTON UNDER CROWN DEPOSITS (MERITS)
960	2	VE	INVLVDEP	4	1	N	MERITS	INTAKE VALVE DEPOSITS (MERITS)
970	2	VE	NSLFTPLG	1	0	N		NUMBER STUCK LIFTER PLUNGERS
980	2	VE	NHSCMPRG	1	0	N		NUMBER HOT STUCK COMPRESSION RINGS
990	2	VE	NSTKORNG	1	0	N		NUMBER STUCK OIL RINGS
1000	2	VE	OILCON	3	0	N	FL. OZ.	OIL CONSUMPTION (FL. OZ.)
1010	2	VE	ACBLWRT1	4	2	N	CFM	AVG CORRECTED BLOWBY FLOW RATE STAGE I (CFM)
1020	3	VE	RSAEVISC	7	0	C		REFERENCE SAE VISCOSITY GRADE
1030	3	VE	RTESTLEN	3	0	Z	HHH	REFERENCE TEST LENGTH (HHH)
1040	3	VE	RENGINE	6	0	C		REFERENCE ENGINE
1050	3	VE	RNOMPISO	4	2	N		REFERENCE NOMINAL PISTON OVERSIZE
1060	3	VE	RFUELBID	2	0	C		REFERENCE FUEL BATCH IDENTIFIER
1070	3	VE	RDTSTRT	8	0	C	YYYYMMDD	REFERENCE STARTING DATE (YYYYMMDD)

FIG. A14.2 Data Dictionary

2-sep-1997

Report: ASTM Data Dictionary

Sequence	Form	Test Area	Field Name	Field Length	Decimal Size	Data Type	Units/Format	Description
1080	3	VE	RSTRTIME	5	0	C	HH:MM	REFERENCE STARTING TIME (HH:MM)
1090	3	VE	RLABCODE	12	0	C		REFERENCE LAB OIL CODE
1100	3	VE	RRACSR	5	2	N	MERITS	REFERENCE ROCKER ARM COVER SLUDGE RATING (MERITS)
1110	3	VE	RTRNRACS	6	3	N	TRANS UNITS	REFERENCE TRANSFORMED RACS RESULTS (TRANS UNITS)
1120	3	VE	RTRCSCOR	6	3	N	TRANS UNITS	REFERENCE TRANSFORMED RACS CORRECTED RATING (TRANS UNITS)
1130	3	VE	RRACSFNL	5	2	N	MERITS	REFERENCE ROCKER ARM COVER FINAL RESULT (MERITS)
1140	3	VE	RCAMBSRT	5	2	N	MERITS	REFERENCE CAMSHAFT BAFFLE SLUDGE RATING (MERITS)
1150	3	VE	RVLVDKRT	5	2	N	MERITS	REFERENCE VALVE DECK SLUDGE RATING (MERITS)
1160	3	VE	RFSLHSRT	5	2	N	MERITS	REFERENCE FRONT SEAL HOUSING SLUDGE RATING (MERITS)
1170	3	VE	RCYLBLRT	5	2	N	MERITS	REFERENCE CYLINDER BLOCK SLUDGE RATING (MERITS)
1180	3	VE	ROILPNRT	5	2	N	MERITS	REFERENCE OIL PAN SLUDGE RATING (MERITS)
1190	3	VE	RAES	5	2	N	MERITS	REFERENCE AVERAGE ENGINE SLUDGE RATING (MERITS)
1200	3	VE	RTRANAES	6	3	N	TRANS UNITS	REFERENCE TRANSFORMED AES RESULTS (TRANS UNITS)
1210	3	VE	RTAESCOR	6	3	N	TRANS UNITS	REFERENCE TRANSFORMED AES CORRECTED RATING (TRANS UNITS)
1220	3	VE	RAESFNL	5	2	N	MERITS	REFERENCE AVERAGE ENGINE SLUDGE FINAL RESULT (MERITS)
1230	3	VE	RPISKVRT	5	2	N	MERITS	REFERENCE AVERAGE PISTON SKIRT VARNISH (MERITS)
1240	3	VE	RPSKVFNL	5	2	N	MERITS	REFERENCE FINAL RESULT PISTON SKIRT VARNISH (MERITS)
1250	3	VE	RRACVRT	5	2	N	MERITS	REFERENCE ROCKER ARM COVER VARNISH RATING (MERITS)
1260	3	VE	RCAMVRT	5	2	N	MERITS	REFERENCE CAMSHAFT BAFFLE VARNISH RATING (MERITS)
1270	3	VE	RCYLWVRT	5	2	N	MERITS	REFERENCE CYLINDER WALLS VARNISH RATING (MERITS)
1280	3	VE	ROILPNVR	5	2	N	MERITS	REFERENCE OIL PAN VARNISH RATING (MERITS)
1290	3	VE	RAEV	5	2	N	MERITS	REFERENCE OIL AVERAGE ENGINE VARNISH RATING (MERITS)
1300	3	VE	RAEVFNL	5	2	N	MERITS	REFERENCE AVERAGE ENGINE VARNISH FINAL RESULT (MERITS)
1310	3	VE	RACW	6	1	N	MICROMETERS	REFERENCE AVG CAMSHAFT WEAR (MICROMETERS)
1320	3	VE	RTACW	6	3	N	TRANS UNITS	REFERENCE TRANSFORMED ACW RESULTS (TRANS UNITS)
1330	3	VE	RTACWCOR	6	3	N	TRANS UNITS	REFERENCE TRANSFORMED ACW CORRECTED RATING (TRANS UNITS)
1340	3	VE	RACWFNL	6	1	N	MICROMETERS	REFERENCE AVG CAMSHAFT WEAR FINAL RESULTS (MICROMETERS)
1350	3	VE	RMCW	6	0	N	MICROMETERS	REFERENCE MAX CAMSHAFT WEAR (MICROMETERS)
1360	3	VE	RTNCW	6	3	N	TRANS UNITS	REFERENCE TRANSFORMED MCW RESULTS (TRANS UNITS)
1370	3	VE	RTNCWCOR	6	3	N	TRANS UNITS	REFERENCE TRANSFORMED MCW CORRECTED RATING (TRANS UNITS)
1380	3	VE	RMCWFNL	6	0	N	MICROMETERS	REFERENCE MAX CAMSHAFT WEAR FINAL RESULT (MICROMETERS)
1390	3	VE	RARAW	6	1	N	MG	REFERENCE AVG ROCKER ARM WEAR (MG)
1400	3	VE	RMAXRAW	6	1	N	MG	REFERENCE MAX ROCKER ARM WEAR (MG)
1410	3	VE	RATRGINC	5	1	N	MILS	REFERENCE AVG TOP RING GAP INCREASE WEAR (MILS)
1420	3	VE	RXTRGINC	5	1	N	MILS	REFERENCE MAX TOP RING GAP INCREASE WEAR (MILS)
1430	3	VE	RARBWL	6	1	N	MG	REFERENCE AVG ROD BEARING WEIGHT LOSS WEAR (MG)
1440	3	VE	RMAXBWL	6	1	N	MG	REFERENCE MAX ROD BEARING WEIGHT LOSS WEAR (MG)
1450	3	VE	ROSCRSLG	4	0	N	% AREA	REFERENCE OIL SCREEN SLUDGE CLOGGING (% AREA)
1460	3	VE	ROSCRDEB	4	0	N	% AREA	REFERENCE OIL SCREEN DEBRIS CLOGGING (% AREA)
1470	3	VE	ROILRING	4	0	N	% AREA	REFERENCE OIL RING CLOGGING (% AREA)
1480	3	VE	RPCV18	4	0	N	% AREA	REFERENCE PCV VALVE AT 18 IN. HG. CLOGGING (% AREA)
1490	3	VE	RPCV8	4	0	N	% AREA	REFERENCE PCV VALVE AT 8 IN. HG. CLOGGING (% AREA)
1500	3	VE	RNCAMLOB	1	0	N		REFERENCE NUMBER OF CAMSHAFT LOBE HOLES CLOGGING
1510	3	VE	RAVGCLD	5	2	N	MERITS	REFERENCE AVG CROWN LAND DEPOSIT (MERITS)
1520	3	VE	RAVGSLD	5	2	N	MERITS	REFERENCE AVG SECOND LAND DEPOSIT (MERITS)
1530	3	VE	RAVGORLD	5	2	N	MERITS	REFERENCE AVG OIL RING LAND DEPOSIT (MERITS)
1540	3	VE	RAVGPUCD	5	2	N	MERITS	REFERENCE AVG PISTON UNDER CROWN DEPOSIT (MERITS)
1550	3	VE	RINVDEP	4	1	N	MERITS	REFERENCE INTAKE VALVE DEPOSITS (MERITS)
1560	3	VE	RSLFTPLG	1	0	N		REFERENCE NUMBER STUCK LIFTER PLUNGERS
1570	3	VE	RHSCMPRG	1	0	N		REFERENCE NUMBER HOT STUCK COMPRESSION RINGS
1580	3	VE	RSTKORNG	1	0	N		REFERENCE NUMBER STUCK OIL RINGS
1590	3	VE	ROILCON	3	0	N	FL. OZ.	REFERENCE OIL CONSUMPTION (FL. OZ.)
1600	3	VE	RABLBYRT	4	2	N	CFM	REFERENCE AVG BLOWBY FLOW RATE (CFM)
1610	3	VE	STATDATE	8	0	C	YYYYMMDD	STAT DATE (YYYYMMDD)

FIG. A14.3 Data Dictionary

2-sep-1997

Report: ASTM Data Dictionary

<u>Sequence</u>	<u>Form</u>	<u>Area</u>	<u>Test Name</u>	<u>Field Length</u>	<u>Field Size</u>	<u>Decimal</u>	<u>Data Type</u>	<u>Units/Format</u>	<u>Description</u>
1620	3	VE	TARGAES	6	3		N	TRANS UNITS	TRANSFORMED AES TARGET VALUE (TRANS UNITS)
1630	3	VE	SAES	6	3		N	STD DEV	TRANSFORMED AES STANDARD DEVIATION (STD DEV)
1640	3	VE	DELAES	6	3		N	TRANS UNITS	TRANSFORMED AES DELTA VALUE (TRANS UNITS)
1650	3	VE	DELSAES	7	3		N	TRANS UNITS	TRANSFORMED AES DELTA/S VALUE (TRANS UNITS)
1660	3	VE	TARRACS	6	3		N	TRANS UNITS	TRANSFORMED RACS TARGET VALUE (TRANS UNITS)
1670	3	VE	SRACS	6	3		N	STD DEV	TRANSFORMED RACS STANDARD DEVIATION (STD DEV)
1680	3	VE	DELRACS	6	3		N	TRANS UNITS	TRANSFORMED RACS DELTA VALUE (TRANS UNITS)
1690	3	VE	DELSRACS	7	3		N	TRANS UNITS	TRANSFORMED RACS DELTA/S VALUE (TRANS UNITS)
1700	3	VE	TARAPV	6	3		N	MERITS	APV TARGET VALUE (MERITS)
1710	3	VE	SAPV	6	3		N	STD DEV	APV STANDARD DEVIATION (STD DEV)
1720	3	VE	DELAPV	6	3		N	MERITS	APV DELTA VALUE (MERITS)
1730	3	VE	DELSAPV	7	3		N	MERITS	APV DELTA/S VALUE (MERITS)
1740	3	VE	TARAEV	6	3		N	MERITS	AEV TARGET VALUE (MERITS)
1750	3	VE	SAEV	6	3		N	STD DEV	AEV STANDARD DEVIATION (STD DEV)
1760	3	VE	DELAEV	6	3		N	MERITS	AEV DELTA VALUE (MERITS)
1770	3	VE	DELSAEV	7	3		N	MERITS	AEV DELTA/S VALUE (MERITS)
1780	3	VE	TARACW	6	3		N	TRANS UNITS	TRANSFORMED ACW TARGET VALUE (TRANS UNITS)
1790	3	VE	SACW	6	3		N	STD DEV	TRANSFORMED ACW STANDARD DEVIATION (STD DEV)
1800	3	VE	DELACW	7	4		N	TRANS UNITS	TRANSFORMED ACW DELTA VALUE (TRANS UNITS)
1810	3	VE	DELSACW	7	3		N	TRANS UNITS	TRANSFORMED ACW DELTA/S VALUE (TRANS UNITS)
1820	3	VE	TARMCW	6	3		N	TRANS UNITS	TRANSFORMED MCW TARGET VALUE (TRANS UNITS)
1830	3	VE	SMCW	6	3		N	STD DEV	TRANSFORMED MCW STANDARD DEVIATION (STD DEV)
1840	3	VE	DELMCW	7	4		N	TRANS UNITS	TRANSFORMED MCW DELTA VALUE (TRANS UNITS)
1850	3	VE	DELSMCW	7	3		N	TRANS UNITS	TRANSFORMED MCW DELTA/S VALUE (TRANS UNITS)
1860	4	VE	XRPM1	4	0		N	R/MIN	MAX ENGINE SPEED STAGE I (R/MIN)
1870	4	VE	IRPM1	4	0		N	R/MIN	MIN ENGINE SPEED STAGE I (R/MIN)
1880	4	VE	ARPM1	4	0		N	R/MIN	AVG ENGINE SPEED STAGE I (R/MIN)
1890	4	VE	XRPM2	4	0		N	R/MIN	MAX ENGINE SPEED STAGE II (R/MIN)
1900	4	VE	IRPM2	4	0		N	R/MIN	MIN ENGINE SPEED STAGE II (R/MIN)
1910	4	VE	ARPM2	4	0		N	R/MIN	AVG ENGINE SPEED STAGE II (R/MIN)
1920	4	VE	XRPM3	4	0		N	R/MIN	MAX ENGINE SPEED STAGE III (R/MIN)
1930	4	VE	IRPM3	4	0		N	R/MIN	MIN ENGINE SPEED STAGE III (R/MIN)
1940	4	VE	ARPM3	4	0		N	R/MIN	AVG ENGINE SPEED STAGE III (R/MIN)
1950	4	VE	XPWR1	5	1		N	BHP	MAX ENGINE POWER STAGE I (BHP)
1960	4	VE	IPWR1	5	1		N	BHP	MIN ENGINE POWER STAGE I (BHP)
1970	4	VE	APWR1	5	1		N	BHP	AVG ENGINE POWER STAGE I (BHP)
1980	4	VE	XPWR2	5	1		N	BHP	MAX ENGINE POWER STAGE II (BHP)
1990	4	VE	IPWR2	5	1		N	BHP	MIN ENGINE POWER STAGE II (BHP)
2000	4	VE	APWR2	5	1		N	BHP	AVG ENGINE POWER STAGE II (BHP)
2010	4	VE	XPWR3	4	1		N	BHP	MAX ENGINE POWER STAGE III (BHP)
2020	4	VE	IPWR3	4	1		N	BHP	MIN ENGINE POWER STAGE III (BHP)
2030	4	VE	APWR3	4	1		N	BHP	AVG ENGINE POWER STAGE III (BHP)
2040	4	VE	XENGOIN1	4	0		N	°F	MAX ENGINE OIL IN TEMP STAGE I (°F)
2050	4	VE	IENGOIN1	4	0		N	°F	MIN ENGINE OIL IN TEMP STAGE I (°F)
2060	4	VE	AENGOIN1	5	1		N	°F	AVG ENGINE OIL IN TEMP STAGE I (°F)
2070	4	VE	XENGOIN2	4	0		N	°F	MAX ENGINE OIL IN TEMP STAGE II (°F)
2080	4	VE	IENGOIN2	4	0		N	°F	MIN ENGINE OIL IN TEMP STAGE II (°F)
2090	4	VE	AENGOIN2	5	1		N	°F	AVG ENGINE OIL IN TEMP STAGE II (°F)
2100	4	VE	XENGOIN3	4	0		N	°F	MAX ENGINE OIL IN TEMP STAGE III (°F)
2110	4	VE	IENGOIN3	4	0		N	°F	MIN ENGINE OIL IN TEMP STAGE III (°F)
2120	4	VE	AENGOIN3	5	1		N	°F	AVG ENGINE OIL IN TEMP STAGE III (°F)
2130	4	VE	XENGODT1	4	0		N	°F	MAX ENGINE OIL DELTA TEMP--OUT-IN STAGE I (°F)
2140	4	VE	IENGODT1	4	0		N	°F	MIN ENGINE OIL DELTA TEMP--OUT-IN STAGE I (°F)
2150	4	VE	AENGODT1	4	0		N	°F	AVG ENGINE OIL DELTA TEMP--OUT-IN STAGE I (°F)

FIG. A14.4 Data Dictionary

2-sep-1997

Report: ASTM Data Dictionary

Sequence	Form	Test Area	Field Name	Field Decimal Data			Units/Format	Description
				Length	Size	Type		
2160	4	VE	XENGOOT2	4	0	N	°F	MAX ENGINE OIL DELTA TEMP--OUT-IN STAGE II (°F)
2170	4	VE	IENGOOT2	4	0	N	°F	MIN ENGINE OIL DELTA TEMP--OUT-IN STAGE II (°F)
2180	4	VE	AENGOOT2	4	0	N	°F	AVG ENGINE OIL DELTA TEMP--OUT-IN STAGE II (°F)
2190	4	VE	XENGOOT3	4	0	N	°F	MAX ENGINE OIL DELTA TEMP--OUT-IN STAGE III (°F)
2200	4	VE	IENGOOT3	4	0	N	°F	MIN ENGINE OIL DELTA TEMP--OUT-IN STAGE III (°F)
2210	4	VE	AENGOOT3	4	0	N	°F	AVG ENGINE OIL DELTA TEMP--OUT-IN STAGE III (°F)
2220	4	VE	XPMPOPR1	5	1	N	PSIG	MAX PUMP OIL PRESSURE STAGE I (PSIG)
2230	4	VE	IPMPOPR1	5	1	N	PSIG	MIN PUMP OIL PRESSURE STAGE I (PSIG)
2240	4	VE	APMPOPR1	5	1	N	PSIG	AVG PUMP OIL PRESSURE STAGE I (PSIG)
2250	4	VE	XPMPOPR2	5	1	N	PSIG	MAX PUMP OIL PRESSURE STAGE II (PSIG)
2260	4	VE	IPMPOPR2	5	1	N	PSIG	MIN PUMP OIL PRESSURE STAGE II (PSIG)
2270	4	VE	APMPOPR2	5	1	N	PSIG	AVG PUMP OIL PRESSURE STAGE II (PSIG)
2280	4	VE	XPMPOPR3	5	1	N	PSIG	MAX PUMP OIL PRESSURE STAGE III (PSIG)
2290	4	VE	IPMPOPR3	5	1	N	PSIG	MIN PUMP OIL PRESSURE STAGE III (PSIG)
2300	4	VE	APMPOPR3	5	1	N	PSIG	AVG PUMP OIL PRESSURE STAGE III (PSIG)
2310	4	VE	XENGOPR1	5	1	N	PSIG	MAX ENGINE OIL PRESSURE STAGE I (PSIG)
2320	4	VE	IENGOPR1	5	1	N	PSIG	MIN ENGINE OIL PRESSURE STAGE I (PSIG)
2330	4	VE	AENGOPR1	5	1	N	PSIG	AVG ENGINE OIL PRESSURE STAGE I (PSIG)
2340	4	VE	XENGOPR2	5	1	N	PSIG	MAX ENGINE OIL PRESSURE STAGE II (PSIG)
2350	4	VE	IENGOPR2	5	1	N	PSIG	MIN ENGINE OIL PRESSURE STAGE II (PSIG)
2360	4	VE	AENGOPR2	5	1	N	PSIG	AVG ENGINE OIL PRESSURE STAGE II (PSIG)
2370	4	VE	XENGOPR3	5	1	N	PSIG	MAX ENGINE OIL PRESSURE STAGE III (PSIG)
2380	4	VE	IENGOPR3	5	1	N	PSIG	MIN ENGINE OIL PRESSURE STAGE III (PSIG)
2390	4	VE	AENGOPR3	5	1	N	PSIG	AVG ENGINE OIL PRESSURE STAGE III (PSIG)
2400	4	VE	XCYLOPR1	5	1	N	PSIG	MAX CYLINDER HEAD OIL PRESSURE STAGE I (PSIG)
2410	4	VE	ICYLOPR1	5	1	N	PSIG	MIN CYLINDER HEAD OIL PRESSURE STAGE I (PSIG)
2420	4	VE	ACYLOPR1	5	1	N	PSIG	AVG CYLINDER HEAD OIL PRESSURE STAGE I (PSIG)
2430	4	VE	XCYLOPR2	5	1	N	PSIG	MAX CYLINDER HEAD OIL PRESSURE STAGE II (PSIG)
2440	4	VE	ICYLOPR2	5	1	N	PSIG	MIN CYLINDER HEAD OIL PRESSURE STAGE II (PSIG)
2450	4	VE	ACYLOPR2	5	1	N	PSIG	AVG CYLINDER HEAD OIL PRESSURE STAGE II (PSIG)
2460	4	VE	XCYLOPR3	5	1	N	PSIG	MAX CYLINDER HEAD OIL PRESSURE STAGE III (PSIG)
2470	4	VE	ICYLOPR3	5	1	N	PSIG	MIN CYLINDER HEAD OIL PRESSURE STAGE III (PSIG)
2480	4	VE	ACYLOPR3	5	1	N	PSIG	AVG CYLINDER HEAD OIL PRESSURE STAGE III (PSIG)
2490	4	VE	XDPPE1	5	1	N	PSI	MAX DELTA PRESSURE--PUMP-ENGINE-- STAGE I (PSI)
2500	4	VE	IDPPE1	5	1	N	PSI	MIN DELTA PRESSURE--PUMP-ENGINE-- STAGE I (PSI)
2510	4	VE	ADPPE1	5	1	N	PSI	AVG DELTA PRESSURE--PUMP-ENGINE-- STAGE I (PSI)
2520	4	VE	XDPPE2	5	1	N	PSI	MAX DELTA PRESSURE--PUMP-ENGINE-- STAGE II (PSI)
2530	4	VE	IDPPE2	5	1	N	PSI	MIN DELTA PRESSURE--PUMP-ENGINE-- STAGE II (PSI)
2540	4	VE	ADPPE2	5	1	N	PSI	AVG DELTA PRESSURE--PUMP-ENGINE-- STAGE II (PSI)
2550	4	VE	XDPPE3	5	1	N	PSI	MAX DELTA PRESSURE--PUMP-ENGINE-- STAGE III (PSI)
2560	4	VE	IDPPE3	5	1	N	PSI	MIN DELTA PRESSURE--PUMP-ENGINE-- STAGE III (PSI)
2570	4	VE	ADPPE3	5	1	N	PSI	AVG DELTA PRESSURE--PUMP-ENGINE-- STAGE III (PSI)
2580	4	VE	XDPEH1	5	1	N	PSI	MAX DELTA PRESSURE--ENGINE-HEAD-- STAGE I (PSI)
2590	4	VE	IDPEH1	5	1	N	PSI	MIN DELTA PRESSURE--ENGINE-HEAD-- STAGE I (PSI)
2600	4	VE	ADPEH1	5	1	N	PSI	AVG DELTA PRESSURE--ENGINE-HEAD-- STAGE I (PSI)
2610	4	VE	XDPEH2	5	1	N	PSI	MAX DELTA PRESSURE--ENGINE-HEAD-- STAGE II (PSI)
2620	4	VE	IDPEH2	5	1	N	PSI	MIN DELTA PRESSURE--ENGINE-HEAD-- STAGE II (PSI)
2630	4	VE	ADPEH2	5	1	N	PSI	AVG DELTA PRESSURE--ENGINE-HEAD-- STAGE II (PSI)
2640	4	VE	XDPEH3	5	1	N	PSI	MAX DELTA PRESSURE--ENGINE-HEAD-- STAGE III (PSI)
2650	4	VE	IDPEH3	5	1	N	PSI	MIN DELTA PRESSURE--ENGINE-HEAD-- STAGE III (PSI)
2660	4	VE	ADPEH3	5	1	N	PSI	AVG DELTA PRESSURE--ENGINE-HEAD-- STAGE III (PSI)
2670	4	VE	XCOLOUT1	4	0	N	°F	MAX ENGINE COOLANT OUT TEMP STAGE I (°F)
2680	4	VE	ICOLOUT1	4	0	N	°F	MIN ENGINE COOLANT OUT TEMP STAGE I (°F)
2690	4	VE	ACOLOUT1	5	1	N	°F	AVG ENGINE COOLANT OUT TEMP STAGE I (°F)

FIG. A14.5 Data Dictionary

2-sep-1997

Report: ASTM Data Dictionary

Sequence	Form	Test Area	Field Name	Field Decimal Data			Units/Format	Description
				Length	Size	Type		
2700	4	VE	XCOLOUT2	4	0	N	°F	MAX ENGINE COOLANT OUT TEMP STAGE II (°F)
2710	4	VE	ICOLOUT2	4	0	N	°F	MIN ENGINE COOLANT OUT TEMP STAGE II (°F)
2720	4	VE	ACOLOUT2	5	1	N	°F	AVG ENGINE COOLANT OUT TEMP STAGE II (°F)
2730	4	VE	XCOLOUT3	4	0	N	°F	MAX ENGINE COOLANT OUT TEMP STAGE III (°F)
2740	4	VE	ICOLOUT3	4	0	N	°F	MIN ENGINE COOLANT OUT TEMP STAGE III (°F)
2750	4	VE	ACOLOUT3	5	1	N	°F	AVG ENGINE COOLANT OUT TEMP STAGE III (°F)
2760	4	VE	XCOLDT1	4	0	N	°F	MAX ENGINE COOLANT DELTA TEMP--OUT-IN--STAGE I (°F)
2770	4	VE	ICOLDT1	4	0	N	°F	MIN ENGINE COOLANT DELTA TEMP--OUT-IN--STAGE I (°F)
2780	4	VE	ACOLDT1	4	0	N	°F	AVG ENGINE COOLANT DELTA TEMP--OUT-IN--STAGE I (°F)
2790	4	VE	XCOLDT2	4	0	N	°F	MAX ENGINE COOLANT DELTA TEMP--OUT-IN--STAGE II (°F)
2800	4	VE	ICOLDT2	4	0	N	°F	MIN ENGINE COOLANT DELTA TEMP--OUT-IN--STAGE II (°F)
2810	4	VE	ACOLDT2	4	0	N	°F	AVG ENGINE COOLANT DELTA TEMP--OUT-IN--STAGE II (°F)
2820	4	VE	XCOLDT3	4	0	N	°F	MAX ENGINE COOLANT DELTA TEMP--OUT-IN--STAGE III (°F)
2830	4	VE	ICOLDT3	4	0	N	°F	MIN ENGINE COOLANT DELTA TEMP--OUT-IN--STAGE III (°F)
2840	4	VE	ACOLDT3	4	0	N	°F	AVG ENGINE COOLANT DELTA TEMP--OUT-IN--STAGE III (°F)
2850	4	VE	XCOLFRT1	5	1	N	GPM	MAX ENGINE COOLANT FLOW RATE STAGE I (GPM)
2860	4	VE	ICOLFRT1	5	1	N	GPM	MIN ENGINE COOLANT FLOW RATE STAGE I (GPM)
2870	4	VE	ACOLFRT1	5	1	N	GPM	AVG ENGINE COOLANT FLOW RATE STAGE I (GPM)
2880	4	VE	XCOLFRT2	5	1	N	GPM	MAX ENGINE COOLANT FLOW RATE STAGE II (GPM)
2890	4	VE	ICOLFRT2	5	1	N	GPM	MIN ENGINE COOLANT FLOW RATE STAGE II (GPM)
2900	4	VE	ACOLFRT2	5	1	N	GPM	AVG ENGINE COOLANT FLOW RATE STAGE II (GPM)
2910	4	VE	XCOLPRE1	5	1	N	PSIG	MAX. ENGINE COOLANT PRESSURE, STAGE I (PSIG)
2920	4	VE	ICOLPRE1	5	1	N	PSIG	MIN. ENGINE COOLANT PRESSURE, STAGE I (PSIG)
2930	4	VE	ACOLPRE1	5	1	N	PSIG	AVG. ENGINE COOLANT PRESSURE, STAGE I (PSIG)
2940	4	VE	XCOLPRE2	5	1	N	PSIG	MAX. ENGINE COOLANT PRESSURE, STAGE II (PSIG)
2950	4	VE	ICOLPRE2	5	1	N	PSIG	MIN. ENGINE COOLANT PRESSURE, STAGE II (PSIG)
2960	4	VE	ACOLPRE2	5	1	N	PSIG	AVG. ENGINE COOLANT PRESSURE, STAGE II (PSIG)
2970	4	VE	XCOLPRE3	5	1	N	PSIG	MAX. ENGINE COOLANT PRESSURE, STAGE III (PSIG)
2980	4	VE	ICOLPRE3	5	1	N	PSIG	MIN. ENGINE COOLANT PRESSURE, STAGE III (PSIG)
2990	4	VE	ACOLPRE3	5	1	N	PSIG	AVG. ENGINE COOLANT PRESSURE, STAGE III (PSIG)
3000	4	VE	XEXCOOL1	3	0	N	°F	MAX EXHAUST MANIFOLD COOLANT TEMP STAGE I (°F)
3010	4	VE	IEXCOOL1	3	0	N	°F	MIN EXHAUST MANIFOLD COOLANT TEMP STAGE I (°F)
3020	4	VE	AEXCOOL1	3	0	N	°F	AVG EXHAUST MANIFOLD COOLANT TEMP STAGE I (°F)
3030	4	VE	XEXCOOL2	3	0	N	°F	MAX EXHAUST MANIFOLD COOLANT TEMP STAGE II (°F)
3040	4	VE	IEXCOOL2	3	0	N	°F	MIN EXHAUST MANIFOLD COOLANT TEMP STAGE II (°F)
3050	4	VE	AEXCOOL2	3	0	N	°F	AVG EXHAUST MANIFOLD COOLANT TEMP STAGE II (°F)
3060	4	VE	XEXCOOL3	3	0	N	°F	MAX EXHAUST MANIFOLD COOLANT TEMP STAGE III (°F)
3070	4	VE	IEXCOOL3	3	0	N	°F	MIN EXHAUST MANIFOLD COOLANT TEMP STAGE III (°F)
3080	4	VE	AEXCOOL3	3	0	N	°F	AVG EXHAUST MANIFOLD COOLANT TEMP STAGE III (°F)
3090	4	VE	XRACCTP1	4	0	N	°F	MAX RAC COOLANT IN TEMP STAGE I (°F)
3100	4	VE	IRACCTP1	4	0	N	°F	MIN RAC COOLANT IN TEMP STAGE I (°F)
3110	4	VE	ARACCTP1	5	1	N	°F	AVG RAC COOLANT IN TEMP STAGE I (°F)
3120	4	VE	XRACCTP2	4	0	N	°F	MAX RAC COOLANT IN TEMP STAGE II (°F)
3130	4	VE	IRACCTP2	4	0	N	°F	MIN RAC COOLANT IN TEMP STAGE II (°F)
3140	4	VE	ARACCTP2	5	1	N	°F	AVG RAC COOLANT IN TEMP STAGE II (°F)
3150	4	VE	XRACCTP3	4	0	N	°F	MAX RAC COOLANT IN TEMP STAGE III (°F)
3160	4	VE	IRACCTP3	4	0	N	°F	MIN RAC COOLANT IN TEMP STAGE III (°F)
3170	4	VE	ARACCTP3	5	1	N	°F	AVG RAC COOLANT IN TEMP STAGE III (°F)
3180	4	VE	XRACCFR1	4	1	N	GPM	MAX RAC COOLANT FLOW RATE STAGE I (GPM)
3190	4	VE	IRACCFR1	4	1	N	GPM	MIN RAC COOLANT FLOW RATE STAGE I (GPM)
3200	4	VE	ARACCFR1	4	1	N	GPM	AVG RAC COOLANT FLOW RATE STAGE I (GPM)
3210	4	VE	XRACCFR3	4	1	N	GPM	MAX RAC COOLANT FLOW RATE STAGE III (GPM)
3220	4	VE	IRACCFR3	4	1	N	GPM	MIN RAC COOLANT FLOW RATE STAGE III (GPM)
3230	4	VE	ARACCFR3	4	1	N	GPM	AVG RAC COOLANT FLOW RATE STAGE III (GPM)

FIG. A14.6 Data Dictionary

2-sep-1997

Report: ASTM Data Dictionary

Sequence	Form	Test Area	Field Name	Field Length	Decimal Data		Units/Format	Description
					Size	Type		
3240	4	VE	XINAIRT1	4	0	N	°F	MAX INTAKE AIR TEMP STAGE I (°F)
3250	4	VE	IINAIRT1	4	0	N	°F	MIN INTAKE AIR TEMP STAGE I (°F)
3260	4	VE	AINAIRT1	4	0	N	°F	AVG INTAKE AIR TEMP STAGE I (°F)
3270	4	VE	XINAIRT2	4	0	N	°F	MAX INTAKE AIR TEMP STAGE II (°F)
3280	4	VE	IINAIRT2	4	0	N	°F	MIN INTAKE AIR TEMP STAGE II (°F)
3290	4	VE	AINAIRT2	4	0	N	°F	AVG INTAKE AIR TEMP STAGE II (°F)
3300	4	VE	XINAIRT3	4	0	N	°F	MAX INTAKE AIR TEMP STAGE III (°F)
3310	4	VE	IINAIRT3	4	0	N	°F	MIN INTAKE AIR TEMP STAGE III (°F)
3320	4	VE	AINAIRT3	4	0	N	°F	AVG INTAKE AIR TEMP STAGE III (°F)
3330	4	VE	XAIRHUM1	3	0	N	GRAINS/LB	MAX INTAKE AIR SPECIFIC HUMIDITY STAGE I (GRAINS/LB)
3340	4	VE	IAIRHUM1	3	0	N	GRAINS/LB	MIN INTAKE AIR SPECIFIC HUMIDITY STAGE I (GRAINS/LB)
3350	4	VE	AAIRHUM1	3	0	N	GRAINS/LB	AVG INTAKE AIR SPECIFIC HUMIDITY STAGE I (GRAINS/LB)
3360	4	VE	XAIRHUM2	3	0	N	GRAINS/LB	MAX INTAKE AIR SPECIFIC HUMIDITY STAGE II (GRAINS/LB)
3370	4	VE	IAIRHUM2	3	0	N	GRAINS/LB	MIN INTAKE AIR SPECIFIC HUMIDITY STAGE II (GRAINS/LB)
3380	4	VE	AAIRHUM2	3	0	N	GRAINS/LB	AVG INTAKE AIR SPECIFIC HUMIDITY STAGE II (GRAINS/LB)
3390	4	VE	XAIRHUM3	3	0	N	GRAINS/LB	MAX INTAKE AIR SPECIFIC HUMIDITY STAGE III (GRAINS/LB)
3400	4	VE	IAIRHUM3	3	0	N	GRAINS/LB	MIN INTAKE AIR SPECIFIC HUMIDITY STAGE III (GRAINS/LB)
3410	4	VE	AAIRHUM3	3	0	N	GRAINS/LB	AVG INTAKE AIR SPECIFIC HUMIDITY STAGE III (GRAINS/LB)
3420	4	VE	XINAIRP1	5	2	N	in. H2O GAGE	MAX INTAKE AIR PRESSURE STAGE I (IN H2O GAGE)
3430	4	VE	IINAIRP1	5	2	N	in. H2O GAGE	MIN INTAKE AIR PRESSURE STAGE I (IN H2O GAGE)
3440	4	VE	AINAIRP1	5	2	N	in. H2O GAGE	AVG INTAKE AIR PRESSURE STAGE I (IN H2O GAGE)
3450	4	VE	XINAIRP2	5	2	N	in. H2O GAGE	MAX INTAKE AIR PRESSURE STAGE II (in. H2O GAGE)
3460	4	VE	IINAIRP2	5	2	N	in. H2O GAGE	MIN INTAKE AIR PRESSURE STAGE II (in. H2O GAGE)
3470	4	VE	AINAIRP2	5	2	N	in. H2O GAGE	AVG INTAKE AIR PRESSURE STAGE II (IN H2O GAGE)
3480	4	VE	XINAIRP3	5	2	N	in. H2O GAGE	MAX INTAKE AIR PRESSURE STAGE III (IN H2O GAGE)
3490	4	VE	IINAIRP3	5	2	N	in. H2O GAGE	MIN INTAKE AIR PRESSURE STAGE III (IN H2O GAGE)
3500	4	VE	AINAIRP3	5	2	N	in. H2O GAGE	AVG INTAKE AIR PRESSURE STAGE III (IN H2O GAGE)
3510	4	VE	XCBLWRT1	4	2	N	CFM	MAX CORRECTED BLOWBY FLOW RATE STAGE I (CFM)
3520	4	VE	ICBLWRT1	4	2	N	CFM	MIN CORRECTED BLOWBY FLOW RATE STAGE I (CFM)
3530	4	VE	XCCASEP1	5	1	N	in. H2O GAGE	MAX CRANKCASE PRESSURE STAGE I (IN H2O GAGE)
3540	4	VE	ICCASEP1	5	1	N	in. H2O GAGE	MIN CRANKCASE PRESSURE STAGE I (IN H2O GAGE)
3550	4	VE	ACCASEP1	5	1	N	in. H2O GAGE	AVG CRANKCASE PRESSURE STAGE I (IN H2O GAGE)
3560	4	VE	XCCASEP2	5	1	N	in. H2O GAGE	MAX CRANKCASE PRESSURE STAGE II (IN H2O GAGE)
3570	4	VE	ICCASEP2	5	1	N	in. H2O GAGE	MIN CRANKCASE PRESSURE STAGE II (IN H2O GAGE)
3580	4	VE	ACCASEP2	5	1	N	in. H2O GAGE	AVG CRANKCASE PRESSURE STAGE II (IN H2O GAGE)
3590	4	VE	XCCASEP3	5	1	N	in. H2O GAGE	MAX CRANKCASE PRESSURE STAGE III (IN H2O GAGE)
3600	4	VE	ICCASEP3	5	1	N	in. H2O GAGE	MIN CRANKCASE PRESSURE STAGE III (IN H2O GAGE)
3610	4	VE	ACCASEP3	5	1	N	in. H2O GAGE	AVG CRANKCASE PRESSURE STAGE III (IN H2O GAGE)
3620	4	VE	XIMNVAC1	5	1	N	in. Hg gage	MAX INTAKE MANIFOLD VACUUM STAGE I (IN HG GAGE)
3630	4	VE	IIMNVAC1	5	1	N	in. Hg gage	MIN INTAKE MANIFOLD VACUUM STAGE I (IN HG GAGE)
3640	4	VE	AIMNVAC1	5	1	N	in. Hg gage	AVG INTAKE MANIFOLD VACUUM STAGE I (IN HG GAGE)
3650	4	VE	XIMNVAC2	5	1	N	in. Hg gage	MAX INTAKE MANIFOLD VACUUM STAGE II (IN HG GAGE)
3660	4	VE	IIMNVAC2	5	1	N	in. Hg gage	MIN INTAKE MANIFOLD VACUUM STAGE II (IN HG GAGE)
3670	4	VE	AIMNVAC2	5	1	N	in. Hg gage	AVG INTAKE MANIFOLD VACUUM STAGE II (IN HG GAGE)
3680	4	VE	XIMNVAC3	5	1	N	in. Hg gage	MAX INTAKE MANIFOLD VACUUM STAGE III (IN HG GAGE)
3690	4	VE	IIMNVAC3	5	1	N	in. Hg gage	MIN INTAKE MANIFOLD VACUUM STAGE III (IN HG GAGE)
3700	4	VE	AIMNVAC3	5	1	N	in. Hg gage	AVG INTAKE MANIFOLD VACUUM STAGE III (IN HG GAGE)
3710	4	VE	XEXBKPR1	5	1	N	in. Hg abs	MAX EXHAUST BACK PRESSURE STAGE I (IN HG ABS)
3720	4	VE	IEXBKPR1	5	1	N	in. Hg abs	MIN EXHAUST BACK PRESSURE STAGE I (IN HG ABS)
3730	4	VE	AEXBKPR1	5	1	N	in. Hg abs	AVG EXHAUST BACK PRESSURE STAGE I (IN HG ABS)
3740	4	VE	XEXBKPR2	5	1	N	in. Hg abs	MAX EXHAUST BACK PRESSURE STAGE II (IN HG ABS)
3750	4	VE	IEXBKPR2	5	1	N	in. Hg abs	MIN EXHAUST BACK PRESSURE STAGE II (IN HG ABS)
3760	4	VE	AEXBKPR2	5	1	N	in. Hg abs	AVG EXHAUST BACK PRESSURE STAGE II (IN HG ABS)
3770	4	VE	XEXBKPR3	5	1	N	in. Hg abs	MAX EXHAUST BACK PRESSURE STAGE III (IN HG ABS)

FIG. A14.7 Data Dictionary

2-sep-1997

Report: ASTM Data Dictionary

Sequence	Form	Test Area	Field Name	Field Length	Decimal Size	Data Type	Units/Format	Description
3780	4	VE	IEXBKPR3	5	1	N	in. Hg abs	MIN EXHAUST BACK PRESSURE STAGE III (IN HG ABS)
3790	4	VE	AEXBKPR3	5	1	N	in. Hg abs	AVG EXHAUST BACK PRESSURE STAGE III (IN HG ABS)
3800	4	VE	XIGNTIM1	2	0	N	BTDC	MAX IGNITION TIMING STAGE I (BTDC)
3810	4	VE	IIGNTIM1	2	0	N	BTDC	MIN IGNITION TIMING STAGE I (BTDC)
3820	4	VE	AIGNTIM1	2	0	N	BTDC	AVG IGNITION TIMING STAGE I (BTDC)
3830	4	VE	XFUELRT1	5	1	N	lb/h	MAX FUEL CONSUMPTION RATE STAGE I (LB/HR)
3840	4	VE	IFUELRT1	5	1	N	lb/h	MIN FUEL CONSUMPTION RATE STAGE I (LB/HR)
3850	4	VE	AFUELRT1	5	1	N	lb/h	AVG FUEL CONSUMPTION RATE STAGE I (LB/HR)
3860	4	VE	XFUELRT2	5	1	N	lb/h	MAX FUEL CONSUMPTION RATE STAGE II (LB/HR)
3870	4	VE	IFUELRT2	5	1	N	lb/h	MIN FUEL CONSUMPTION RATE STAGE II (LB/HR)
3880	4	VE	AFUELRT2	5	1	N	lb/h	AVG FUEL CONSUMPTION RATE STAGE II (LB/HR)
3890	4	VE	XFUELRT3	4	1	N	lb/h	MAX FUEL CONSUMPTION RATE STAGE III (LB/HR)
3900	4	VE	IFUELRT3	4	1	N	lb/h	MIN FUEL CONSUMPTION RATE STAGE III (LB/HR)
3910	4	VE	AFUELRT3	4	1	N	lb/h	AVG FUEL CONSUMPTION RATE STAGE III (LB/HR)
3920	4	VE	XEXHGO1	5	2	N	%	MAX EXHAUST GAS OXYGEN STAGE I (%)
3930	4	VE	IEXHGO1	5	2	N	%	MIN EXHAUST GAS OXYGEN STAGE I (%)
3940	4	VE	AEXHGO1	5	2	N	%	AVG EXHAUST GAS OXYGEN STAGE I (%)
3950	4	VE	XEXHGO2	5	2	N	%	MAX EXHAUST GAS OXYGEN STAGE II (%)
3960	4	VE	IEXHGO2	5	2	N	%	MIN EXHAUST GAS OXYGEN STAGE II (%)
3970	4	VE	AEXHGO2	5	2	N	%	AVG EXHAUST GAS OXYGEN STAGE II (%)
3980	4	VE	XEXHGO3	5	2	N	%	MAX EXHAUST GAS OXYGEN STAGE III (%)
3990	4	VE	IEXHGO3	5	2	N	%	MIN EXHAUST GAS OXYGEN STAGE III (%)
4000	4	VE	AEXHGO3	5	2	N	%	AVG EXHAUST GAS OXYGEN STAGE III (%)
4010	4	VE	XEXHGCO1	5	2	N	%	MAX EXHAUST GAS CARBON MONOXIDE STAGE I (%)
4020	4	VE	IEXHGCO1	5	2	N	%	MIN EXHAUST GAS CARBON MONOXIDE STAGE I (%)
4030	4	VE	AEXHGCO1	5	2	N	%	AVG EXHAUST GAS CARBON MONOXIDE STAGE I (%)
4040	4	VE	XEXHGCO2	5	2	N	%	MAX EXHAUST GAS CARBON MONOXIDE STAGE II (%)
4050	4	VE	IEXHGCO2	5	2	N	%	MIN EXHAUST GAS CARBON MONOXIDE STAGE II (%)
4060	4	VE	AEXHGCO2	5	2	N	%	AVG EXHAUST GAS CARBON MONOXIDE STAGE II (%)
4070	4	VE	XEXHGCO3	5	2	N	%	MAX EXHAUST GAS CARBON MONOXIDE STAGE III (%)
4080	4	VE	IEXHGCO3	5	2	N	%	MIN EXHAUST GAS CARBON MONOXIDE STAGE III (%)
4090	4	VE	AEXHGCO3	5	2	N	%	AVG EXHAUST GAS CARBON MONOXIDE STAGE III (%)
4100	4	VE	XEXHGNO2	4	0	N	PPM	MAX EXHAUST GAS NOX STAGE II (PPM)
4110	4	VE	IEXHGNO2	4	0	N	PPM	MIN EXHAUST GAS NOX STAGE II (PPM)
4120	4	VE	AEXHGNO2	4	0	N	PPM	AVG EXHAUST GAS NOX STAGE II (PPM)
4130	5	VE	OPROCR	3	0	Z		REMARKS OR DEVIATIONS, LINE COUNT
4140	5	VE	ITEMHxxx	3	0	C		OPERATIONAL DATA ITEM
4150	5	VE	REMKHxxx	70	0	C		OPERATIONAL DATA REMARKS OR DEVIATIONS
4160	6	VE	DWNOCR	3	0	Z	#	DOWNTIME OCCURRENCES (#)
4170	6	VE	TYPEHxxx	1	0	C		SHUTDOWN TYPE
4180	6	VE	TESTHxxx	6	0	C	HHH:MM	TEST HOURS (HHH:MM)
4190	6	VE	STGEHxxx	1	0	C		STAGE
4200	6	VE	DTIMHxxx	6	0	C	HHH:MM	DOWNTIME TIME (HHH:MM)
4210	6	VE	LSTMHxxx	6	0	C	HHH:MM	LOST TIME (HHH:MM)
4220	6	VE	DREAHxxx	60	0	C		DOWNTIME PROBLEMS/ACTIONS/COMMENTS
4230	6	VE	TOTLDOWN	6	0	C	HHH:MM	DOWN TIME, TOTAL (HHH:MM)
4240	6	VE	TOTLLOST	6	0	C	HHH:MM	LOST TIME, TOTAL (HHH:MM)
4250	7	VE	FE_Hxxx	6	0	N	PPM	IRON HOURS (PPM)
4260	7	VE	CU_Hxxx	6	0	N	PPM	COPPER HOURS (PPM)
4270	7	VE	SI_Hxxx	6	0	N	PPM	SILICON HOURS (PPM)
4280	7	VE	VS40Hxxx	7	2	N	CST	VISCOSITY @ 40 °C HOURS (CST)
4290	7	VE	FUELHxxx	5	1	N	% MASS	FUEL DILUTION HOURS (% MASS)
4300	7	VE	PENTHxxx	5	1	N	% VOLUME	PENTANE INSOLUBLES HOURS (% VOLUME)
4310	8	VE	CAMW01	6	0	N	MICROMETERS	CAM LOBE WEAR POSITION 1-1E (MICROMETERS)

FIG. A14.8 Data Dictionary

2-sep-1997

Report: ASTM Data Dictionary

Sequence	Form	Test Area	Field Name	Field Length	Decimal Size	Data Type	Units/Format	Description
4320	8	VE	LOBPLG01	3	0	N	% VOLUME	LOBE ORIFICE PLUGGING POSITION 1-1E (% VOLUME)
4330	8	VE	ROCKW01	6	1	N	MG	ROCKER ARM WEAR POSITION 1-1E (MG)
4340	8	VE	VSPGLD01	6	1	N	LBF	VALVE SPRING LOAD POSITION 1-1E (LBF)
4350	8	VE	CAMW02	6	0	N	MICROMETERS	CAM LOBE WEAR POSITION 2-1I (MICROMETERS)
4360	8	VE	LOBPLG02	3	0	N	% VOLUME	LOBE ORIFICE PLUGGING POSITION 2-1I (% VOLUME)
4370	8	VE	ROCKW02	6	1	N	MG	ROCKER ARM WEAR POSITION 2-1I (MG)
4380	8	VE	VSPGLD02	6	1	N	LBF	VALVE SPRING LOAD POSITION 2-1I (LBF)
4390	8	VE	CAMW03	6	0	N	MICROMETERS	CAM LOBE WEAR POSITION 3-2E (MICROMETERS)
4400	8	VE	LOBPLG03	3	0	N	% VOLUME	LOBE ORIFICE PLUGGING POSITION 3-2E (% VOLUME)
4410	8	VE	ROCKW03	6	1	N	MG	ROCKER ARM WEAR POSITION 3-2E (MG)
4420	8	VE	VSPGLD03	6	1	N	LBF	VALVE SPRING LOAD POSITION 3-2E (LBF)
4430	8	VE	CAMW04	6	0	N	MICROMETERS	CAM LOBE WEAR POSITION 4-2I (MICROMETERS)
4440	8	VE	LOBPLG04	3	0	N	% VOLUME	LOBE ORIFICE PLUGGING POSITION 4-2I (% VOLUME)
4450	8	VE	ROCKW04	6	1	N	MG	ROCKER ARM WEAR POSITION 4-2I (MG)
4460	8	VE	VSPGLD04	6	1	N	LBF	VALVE SPRING LOAD POSITION 4-2I (LBF)
4470	8	VE	CAMW05	6	0	N	MICROMETERS	CAM LOBE WEAR POSITION 5-3E (MICROMETERS)
4480	8	VE	LOBPLG05	3	0	N	% VOLUME	LOBE ORIFICE PLUGGING POSITION 5-3E (% VOLUME)
4490	8	VE	ROCKW05	6	1	N	MG	ROCKER ARM WEAR POSITION 5-3E (MG)
4500	8	VE	VSPGLD05	6	1	N	LBF	VALVE SPRING LOAD POSITION 5-3E (LBF)
4510	8	VE	CAMW06	6	0	N	MICROMETERS	CAM LOBE WEAR POSITION 6-3I (MICROMETERS)
4520	8	VE	LOBPLG06	3	0	N	% VOLUME	LOBE ORIFICE PLUGGING POSITION 6-3I (% VOLUME)
4530	8	VE	ROCKW06	6	1	N	MG	ROCKER ARM WEAR POSITION 6-3I (MG)
4540	8	VE	VSPGLD06	6	1	N	LBF	VALVE SPRING LOAD POSITION 6-3I (LBF)
4550	8	VE	CAMW07	6	0	N	MICROMETERS	CAM LOBE WEAR POSITION 7-4E (MICROMETERS)
4560	8	VE	LOBPLG07	3	0	N	% VOLUME	LOBE ORIFICE PLUGGING POSITION 7-4E (% VOLUME)
4570	8	VE	ROCKW07	6	1	N	MG	ROCKER ARM WEAR POSITION 7-4E (MG)
4580	8	VE	VSPGLD07	6	1	N	LBF	VALVE SPRING LOAD POSITION 7-4E (LBF)
4590	8	VE	CAMW08	6	0	N	MICROMETERS	CAM LOBE WEAR POSITION 8-4I (MICROMETERS)
4600	8	VE	LOBPLG08	3	0	N	% VOLUME	LOBE ORIFICE PLUGGING POSITION 8-4I (% VOLUME)
4610	8	VE	ROCKW08	6	1	N	MG	ROCKER ARM WEAR POSITION 8-4I (MG)
4620	8	VE	VSPGLD08	6	1	N	LBF	VALVE SPRING LOAD POSITION 8-4I (LBF)
4630	8	VE	AVGLOBPL	3	0	N	% VOLUME	LOBE ORIFICE PLUGGING POSITION AVG (% VOLUME)
4640	8	VE	AVGSPGLO	6	1	N	LBF	VALVE SPRING LOAD POSITION AVG (LBF)
4650	8	VE	LOBHRD01	5	1	N	ROCKWELL C	LOBE HARDNESS 1E->50 ROCKWELL C- (ROCKWELL C)
4660	8	VE	RCKHRD01	5	1	N	ROCKWELL C	ROCKER ARM HARDNESS 1E->57 ROCKWELL C- (ROCKWELL C)
4670	8	VE	LOBHRD02	5	1	N	ROCKWELL C	LOBE HARDNESS 1I->50 ROCKWELL C- (ROCKWELL C)
4680	8	VE	RCKHRD02	5	1	N	ROCKWELL C	ROCKER ARM HARDNESS 1I->57 ROCKWELL C- (ROCKWELL C)
4690	8	VE	LOBHRD03	5	1	N	ROCKWELL C	LOBE HARDNESS 2E->50 ROCKWELL C- (ROCKWELL C)
4700	8	VE	RCKHRD03	5	1	N	ROCKWELL C	ROCKER ARM HARDNESS 2E->57 ROCKWELL C- (ROCKWELL C)
4710	8	VE	LOBHRD04	5	1	N	ROCKWELL C	LOBE HARDNESS 2I->50 ROCKWELL C- (ROCKWELL C)
4720	8	VE	RCKHRD04	5	1	N	ROCKWELL C	ROCKER ARM HARDNESS 2I->57 ROCKWELL C- (ROCKWELL C)
4730	8	VE	LOBHRD05	5	1	N	ROCKWELL C	LOBE HARDNESS 3E->50 ROCKWELL C- (ROCKWELL C)
4740	8	VE	RCKHRD05	5	1	N	ROCKWELL C	ROCKER ARM HARDNESS 3E->57 ROCKWELL C- (ROCKWELL C)
4750	8	VE	LOBHRD06	5	1	N	ROCKWELL C	LOBE HARDNESS 3I->50 ROCKWELL C- (ROCKWELL C)
4760	8	VE	RCKHRD06	5	1	N	ROCKWELL C	ROCKER ARM HARDNESS 3I->57 ROCKWELL C- (ROCKWELL C)
4770	8	VE	LOBHRD07	5	1	N	ROCKWELL C	LOBE HARDNESS 4E->50 ROCKWELL C- (ROCKWELL C)
4780	8	VE	RCKHRD07	5	1	N	ROCKWELL C	ROCKER ARM HARDNESS 4E->57 ROCKWELL C- (ROCKWELL C)
4790	8	VE	LOBHRD08	5	1	N	ROCKWELL C	LOBE HARDNESS 4I->50 ROCKWELL C- (ROCKWELL C)
4800	8	VE	RCKHRD08	5	1	N	ROCKWELL C	ROCKER ARM HARDNESS 4I->57 ROCKWELL C- (ROCKWELL C)
4810	9	VE	PSVTH1	4	1	N	MERITS	PISTON SKIRT VARNISH THRUST NUM 1 (MERITS)
4820	9	VE	PSVAT1	4	1	N	MERITS	PISTON SKIRT VARNISH ANTITHRUST NUM 1 (MERITS)
4830	9	VE	PSVTH2	4	1	N	MERITS	PISTON SKIRT VARNISH THRUST NUM 2 (MERITS)
4840	9	VE	PSVAT2	4	1	N	MERITS	PISTON SKIRT VARNISH ANTITHRUST NUM 2 (MERITS)
4850	9	VE	PSVTH3	4	1	N	MERITS	PISTON SKIRT VARNISH THRUST NUM 3 (MERITS)

FIG. A14.9 Data Dictionary

2-sep-1997

Report: ASTM Data Dictionary

Sequence	Test		Field Name	Field Decimal Data			Units/Format	Description
	Form	Area		Length	Size	Type		
4860	9	VE	PSVAT3	4	1	N	MERITS	PISTON SKIRT VARNISH ANTITHRUST NUM 3 (MERITS)
4870	9	VE	PSVTH4	4	1	N	MERITS	PISTON SKIRT VARNISH THRUST NUM 4 (MERITS)
4880	9	VE	PSVAT4	4	1	N	MERITS	PISTON SKIRT VARNISH ANTITHRUST NUM 4 (MERITS)
4890	9	VE	PSVTHAVG	5	2	N	MERITS	PISTON SKIRT VARNISH THRUST AVG (MERITS)
4900	9	VE	PSVATAVG	5	2	N	MERITS	PISTON SKIRT VARNISH ANTITHRUST AVG (MERITS)
4910	9	VE	CLD1	5	2	N	MERITS	PISTON NUMBER 1 UNDERCROWN (MERITS)
4920	9	VE	SECLD1	5	2	N	MERITS	PISTON NUMBER 1 2ND LAND (MERITS)
4930	9	VE	ORLD1	5	2	N	MERITS	PISTON NUMBER 1 OIL RING LAND (MERITS)
4940	9	VE	PISUC1	5	2	N	MERITS	PISTON NUMBER 1 UNDERCROWN (MERITS)
4950	9	VE	CLD2	5	2	N	MERITS	PISTON NUMBER 2 CROWN LAND (MERITS)
4960	9	VE	SECLD2	5	2	N	MERITS	PISTON NUMBER 2 2ND LAND (MERITS)
4970	9	VE	ORLD2	5	2	N	MERITS	PISTON NUMBER 2 OIL RING LAND (MERITS)
4980	9	VE	PISUC2	5	2	N	MERITS	PISTON NUMBER 2 UNDERCROWN (MERITS)
4990	9	VE	CLD3	5	2	N	MERITS	PISTON NUMBER 3 CROWN LAND (MERITS)
5000	9	VE	SECLD3	5	2	N	MERITS	PISTON NUMBER 3 2ND LAND (MERITS)
5010	9	VE	ORLD3	5	2	N	MERITS	PISTON NUMBER 3 OIL RING LAND (MERITS)
5020	9	VE	PISUC3	5	2	N	MERITS	PISTON NUMBER 3 UNDERCROWN (MERITS)
5030	9	VE	CLD4	5	2	N	MERITS	PISTON NUMBER 4 CROWN LAND (MERITS)
5040	9	VE	SECLD4	5	2	N	MERITS	PISTON NUMBER 4 2ND LAND (MERITS)
5050	9	VE	ORLD4	5	2	N	MERITS	PISTON NUMBER 4 OIL RING LAND (MERITS)
5060	9	VE	PISUC4	5	2	N	MERITS	PISTON NUMBER 4 UNDERCROWN (MERITS)
5070	10	VE	BLOWBYM	70	0	C		CORRECTED BLOWBY FLOWRATE PLOT
5080	11	VE	OILCHxxx	3	0	N	FL. OZ.	OIL CONSUMPTION CYCLE XXX (FL. OZ.)
5090	11	VE	OILLHxxx	3	0	N	FL. OZ.	OIL LEVEL CYCLE XXX (FL. OZ.)
5100	12	VE	CANOGN	4	0	N	YYYY	CAMSHAFT ORIGIN (YYYY)
5110	12	VE	CROBBOGN	4	0	N	YYYY	CONNECTING ROD BEARINGS ORIGIN (YYYY)
5120	12	VE	CYLBKOGN	4	0	N	YYYY	CYLINDER BLOCK ORIGIN (YYYY)
5130	12	VE	CYLNDOGN	4	0	N	YYYY	CYLINDER HEAD ORIGIN (YYYY)
5140	12	VE	PISTOGN	4	0	N	YYYY	PISTONS ORIGIN (YYYY)
5150	12	VE	PISRGOGN	4	0	N	YYYY	PISTON RINGS ORIGIN (YYYY)
5160	12	VE	RCKRAOGN	4	0	N	YYYY	ROCKER ARMS ORIGIN (YYYY)
5170	13	VE	OILISENS	14	0	C		OIL INLET SENSING DEVICE
5180	13	VE	OILICALF	14	0	C		OIL INLET CALIBRATION FREQUENCY
5190	13	VE	OILIRECD	3	0	C		OIL INLET RECORD DEVICE
5200	13	VE	OILIOBSF	12	0	C		OIL INLET OBSERVATION FREQUENCY
5210	13	VE	OILIRECF	12	0	C		OIL INLET RECORD FREQUENCY
5220	13	VE	OILILOGF	12	0	C		OIL INLET LOG FREQUENCY
5230	13	VE	RCCISENS	14	0	C		RAC INLET SENSING DEVICE
5240	13	VE	RCCICALF	14	0	C		RAC INLET CALIBRATION FREQUENCY
5250	13	VE	RCCIRECD	3	0	C		RAC INLET RECORD DEVICE
5260	13	VE	RCCIOBSF	12	0	C		RAC INLET OBSERVATION FREQUENCY
5270	13	VE	RCCIRECF	12	0	C		RAC INLET RECORD FREQUENCY
5280	13	VE	RCCILOGF	12	0	C		RAC INLET LOG FREQUENCY
5290	13	VE	COTSENS	14	0	C		COOLANT OUT TEMPERATURE SENSING DEVICE
5300	13	VE	COTCALF	14	0	C		COOLANT OUT TEMPERATURE CALIBRATION FREQUENCY
5310	13	VE	COTRECD	3	0	C		COOLANT OUT TEMPERATURE RECORD DEVICE
5320	13	VE	COTOBSF	12	0	C		COOLANT OUT TEMPERATURE OBSERVATION FREQUENCY
5330	13	VE	COTRECF	12	0	C		COOLANT OUT TEMPERATURE RECORD FREQUENCY
5340	13	VE	COTLOGF	12	0	C		COOLANT OUT TEMPERATURE LOG FREQUENCY
5350	13	VE	RPMSENS	14	0	C		ENGINE SPEED SENSING DEVICE
5360	13	VE	RPMCALF	14	0	C		ENGINE SPEED CALIBRATION FREQUENCY
5370	13	VE	RPMRECD	3	0	C		ENGINE SPEED RECORD DEVICE
5380	13	VE	RPMOBSF	12	0	C		ENGINE SPEED OBSERVATION FREQUENCY
5390	13	VE	RPMRECF	12	0	C		ENGINE SPEED RECORD FREQUENCY

FIG. A14.10 Data Dictionary

2-sep-1997

Report: ASTM Data Dictionary

<u>Sequence</u>	<u>Form</u>	<u>Test Area</u>	<u>Field Name</u>	<u>Field Length</u>	<u>Decimal Size</u>	<u>Data Type</u>	<u>Units/Format</u>	<u>Description</u>
5400	13	VE	RPMLGPF	12	0	C		ENGINE SPEED LOG FREQUENCY
5410	13	VE	RPMSYSR	8	0	C		ENGINE SPEED SYSTEM RESPONSE
5420	13	VE	PWRSENS	14	0	C		POWER SENSING DEVICE
5430	13	VE	PWRCALF	14	0	C		POWER CALIBRATION FREQUENCY
5440	13	VE	PWRRECD	3	0	C		POWER RECORD DEVICE
5450	13	VE	PWROBSF	12	0	C		POWER OBSERVATION FREQUENCY
5460	13	VE	PWRRECF	12	0	C		POWER RECORD FREQUENCY
5470	13	VE	PWRLOGF	12	0	C		POWER LOG FREQUENCY
5480	13	VE	PWRSYSR	8	0	C		POWER SYSTEM RESPONSE
5490	13	VE	COSENS	14	0	C		CARBON MONOXIDE SENSING DEVICE
5500	13	VE	COCALF	14	0	C		CARBON MONOXIDE CALIBRATION FREQUENCY
5510	13	VE	CORECD	3	0	C		CARBON MONOXIDE RECORD DEVICE
5520	13	VE	COBSF	12	0	C		CARBON MONOXIDE OBSERVATION FREQUENCY
5530	13	VE	CORECF	12	0	C		CARBON MONOXIDE RECORD FREQUENCY
5540	13	VE	COLOGF	12	0	C		CARBON MONOXIDE LOG FREQUENCY
5550	13	VE	COSYSR	8	0	C		CARBON MONOXIDE SYSTEM RESPONSE
5560	13	VE	O2SENS	14	0	C		OXYGEN SENSING DEVICE
5570	13	VE	O2CALF	14	0	C		OXYGEN CALIBRATION FREQUENCY
5580	13	VE	O2RECD	3	0	C		OXYGEN RECORD DEVICE
5590	13	VE	O2OBSF	12	0	C		OXYGEN OBSERVATION FREQUENCY
5600	13	VE	O2RECF	12	0	C		OXYGEN RECORD FREQUENCY
5610	13	VE	O2LOGF	12	0	C		OXYGEN LOG FREQUENCY
5620	13	VE	O2SYSR	8	0	C		OXYGEN SYSTEM RESPONSE
5630	13	VE	TIMGSENS	14	0	C		TIMING SENSING DEVICE
5640	13	VE	TIMGCALF	14	0	C		TIMING CALIBRATION FREQUENCY
5650	13	VE	TIMGRECD	3	0	C		TIMING RECORD DEVICE
5660	13	VE	TIMGBSF	12	0	C		TIMING OBSERVATION FREQUENCY
5670	13	VE	TIMGRECF	12	0	C		TIMING RECORD FREQUENCY
5680	13	VE	TIMGLOGF	12	0	C		TIMING LOG FREQUENCY
5690	13	VE	BLWGSNS	14	0	C		BLOWBY GAS SENSING DEVICE
5700	13	VE	BLWGALF	14	0	C		BLOWBY GAS CALIBRATION FREQUENCY
5710	13	VE	BLWGRECD	3	0	C		BLOWBY GAS RECORD DEVICE
5720	13	VE	BLWGBSF	12	0	C		BLOWBY GAS OBSERVATION FREQUENCY
5730	13	VE	BLWGRECF	12	0	C		BLOWBY GAS RECORD FREQUENCY
5740	13	VE	BLWGLOGF	12	0	C		BLOWBY GAS LOG FREQUENCY
5750	13	VE	EXPRSNS	14	0	C		EXHAUST PRESSURE SENSING DEVICE
5760	13	VE	EXPRCALF	14	0	C		EXHAUST PRESSURE CALIBRATION FREQUENCY
5770	13	VE	EXPRECD	3	0	C		EXHAUST PRESSURE RECORD DEVICE
5780	13	VE	EXPROBSF	12	0	C		EXHAUST PRESSURE OBSERVATION FREQUENCY
5790	13	VE	EXPRECF	12	0	C		EXHAUST PRESSURE RECORD FREQUENCY
5800	13	VE	EXPRLOGF	12	0	C		EXHAUST PRESSURE LOG FREQUENCY
5810	13	VE	CFLWSNS	14	0	C		ENGINE COOLANT FLOW SENSING DEVICE
5820	13	VE	CFLWCALF	14	0	C		ENGINE COOLANT FLOW CALIBRATION FREQUENCY
5830	13	VE	CFLWRECD	3	0	C		ENGINE COOLANT FLOW RECORD DEVICE
5840	13	VE	CFLWBSF	12	0	C		ENGINE COOLANT FLOW OBSERVATION FREQUENCY
5850	13	VE	CFLWRECF	12	0	C		ENGINE COOLANT FLOW RECORD FREQUENCY
5860	13	VE	CFLWLOGF	12	0	C		ENGINE COOLANT FLOW LOG FREQUENCY
5870	13	VE	RCCFSNS	14	0	C		ROCKER ARM FLOW SENSING DEVICE
5880	13	VE	RCCFCALF	14	0	C		ROCKER ARM FLOW CALIBRATION FREQUENCY
5890	13	VE	RCCFRECD	3	0	C		ROCKER ARM FLOW RECORD DEVICE
5900	13	VE	RCCFOBSF	12	0	C		ROCKER ARM FLOW OBSERVATION FREQUENCY
5910	13	VE	RCCFRECF	12	0	C		ROCKER ARM FLOW RECORD FREQUENCY
5920	13	VE	RCCFLOGF	12	0	C		ROCKER ARM FLOW LOG FREQUENCY
5930	14	VE	RC_CSBIM	70	0	C		ROCKER COVER AND CAMSHAFT BAFFLE IMAGES

FIG. A14.11 Data Dictionary

2-sep-1997

Report: ASTM Data Dictionary

Sequence	Form	Test Area	Field Name	Field Decimal Data			Description
				Length	Size	Type Units/Format	
5940	15	VE	OP_OSIM	70	0	C	OIL PAN AND OIL SCREEN IMAGES
5950	16	VE	PISTONIM	70	0	C	PISTON SKIRT IMAGES
5960	17	VE	CAMLOBIM	70	0	C	CAMSHAFT LOBE IMAGES
5970	18	VE	FSH_RAIM	70	0	C	FRONT SEAL HOUSING AND ROCKER ARM IMAGES
5980	19	VE	TRANSIIM	70	0	C	SAMPLE TRANSITION PLOT IMAGE
5990	20	VE	TPRNGGP1	5	3	N IN	TOP RING GAP, CYLINDER 1 (IN)
6000	20	VE	N2RNGGP1	5	3	N IN	SECOND RING GAP, CYLINDER 1 (IN)
6010	20	VE	TPRLCLR1	6	4	N IN	TOP RING-LAND SIDE CLEARANCE, CYLINDER 1 (IN)
6020	20	VE	N2RLCLR1	6	4	N IN	SECOND RING-LAND SIDE CLEARANCE, CYLINDER 1 (IN)
6030	20	VE	TPRNGGP2	5	3	N IN	TOP RING GAP, CYLINDER 2 (IN)
6040	20	VE	N2RNGGP2	5	3	N IN	SECOND RING GAP, CYLINDER 2 (IN)
6050	20	VE	TPRLCLR2	6	4	N IN	TOP RING-LAND SIDE CLEARANCE, CYLINDER 2 (IN)
6060	20	VE	N2RLCLR2	6	4	N IN	SECOND RING-LAND SIDE CLEARANCE, CYLINDER 2 (IN)
6070	20	VE	TPRNGGP3	5	3	N IN	TOP RING GAP, CYLINDER 3 (IN)
6080	20	VE	N2RNGGP3	5	3	N IN	SECOND RING GAP, CYLINDER 3 (IN)
6090	20	VE	TPRLCLR3	6	4	N IN	TOP RING-LAND SIDE CLEARANCE, CYLINDER 3 (IN)
6100	20	VE	N2RLCLR3	6	4	N IN	SECOND RING-LAND SIDE CLEARANCE, CYLINDER 3 (IN)
6110	20	VE	TPRNGGP4	5	3	N IN	TOP RING GAP, CYLINDER 4 (IN)
6120	20	VE	N2RNGGP4	5	3	N IN	SECOND RING GAP, CYLINDER 4 (IN)
6130	20	VE	TPRLCLR4	6	4	N IN	TOP RING-LAND SIDE CLEARANCE, CYLINDER 4 (IN)
6140	20	VE	N2RLCLR4	6	4	N IN	SECOND RING-LAND SIDE CLEARANCE, CYLINDER 4 (IN)
6150	20	VE	GAPHRA	3	0	C HOURS	TEST HOUR WHEN REGAP OCCURS -- A (HOURS)
6160	20	VE	GAPHRB	3	0	C HOURS	TEST HOUR WHEN REGAP OCCURS -- B (HOURS)
6170	20	VE	TPRGGP1A	5	3	N IN	TOP RING GAP @ XXX HRS, CYLINDER 1A (IN)
6180	20	VE	TPRGRW1A	5	3	N IN	TOP RING GAP AFTER REWORK, CYLINDER 1A (IN)
6190	20	VE	TPRGGP1B	5	3	N IN	TOP RING GAP @ XXX HRS, CYLINDER 1B (IN)
6200	20	VE	TPRGRW1B	5	3	N IN	TOP RING GAP AFTER REWORK, CYLINDER 1B (IN)
6210	20	VE	TPRGINC1	5	3	N IN	TOP RING GAP INCREASE DUE WEAR, CYLINDER 1 (IN)
6220	20	VE	TPRGGP2A	5	3	N IN	TOP RING GAP @ XXX HRS, CYLINDER 2A (IN)
6230	20	VE	TPRGRW2A	5	3	N IN	TOP RING GAP AFTER REWORK, CYLINDER 2A (IN)
6240	20	VE	TPRGGP2B	5	3	N IN	TOP RING GAP @ XXX HRS, CYLINDER 2B (IN)
6250	20	VE	TPRGRW2B	5	3	N IN	TOP RING GAP AFTER REWORK, CYLINDER 2B (IN)
6260	20	VE	TPRGINC2	5	3	N IN	TOP RING GAP INCREASE DUE WEAR, CYLINDER 2 (IN)
6270	20	VE	TPRGGP3A	5	3	N IN	TOP RING GAP @ XXX HRS, CYLINDER 3A (IN)
6280	20	VE	TPRGRW3A	5	3	N IN	TOP RING GAP AFTER REWORK, CYLINDER 3A (IN)
6290	20	VE	TPRGGP3B	5	3	N IN	TOP RING GAP @ XXX HRS, CYLINDER 3B (IN)
6300	20	VE	TPRGRW3B	5	3	N IN	TOP RING GAP AFTER REWORK, CYLINDER 3B (IN)
6310	20	VE	TPRGINC3	5	3	N IN	TOP RING GAP INCREASE DUE WEAR, CYLINDER 3 (IN)
6320	20	VE	TPRGGP4A	5	3	N IN	TOP RING GAP @ XXX HRS, CYLINDER 4A (IN)
6330	20	VE	TPRGRW4A	5	3	N IN	TOP RING GAP AFTER REWORK, CYLINDER 4A (IN)
6340	20	VE	TPRGGP4B	5	3	N IN	TOP RING GAP @ XXX HRS, CYLINDER 4B (IN)
6350	20	VE	TPRGRW4B	5	3	N IN	TOP RING GAP AFTER REWORK, CYLINDER 4B (IN)
6360	20	VE	TPRGINC4	5	3	N IN	TOP RING GAP INCREASE DUE WEAR, CYLINDER 4 (IN)
6370	20	VE	BWCYL1T	6	1	N MILS	BORE WEAR CYLINDER 1 TOP (MILS)
6380	20	VE	BWCYL1M	6	1	N MILS	BORE WEAR CYLINDER 1 MIDDLE (MILS)
6390	20	VE	BWCYL1B	6	1	N MILS	BORE WEAR CYLINDER 1 BOTTOM (MILS)
6400	20	VE	BWCYL1A	6	1	N MILS	BORE WEAR CYLINDER 1 AVERAGE (MILS)
6410	20	VE	BWCYL2T	6	1	N MILS	BORE WEAR CYLINDER 2 TOP (MILS)
6420	20	VE	BWCYL2M	6	1	N MILS	BORE WEAR CYLINDER 2 MIDDLE (MILS)
6430	20	VE	BWCYL2B	6	1	N MILS	BORE WEAR CYLINDER 2 BOTTOM (MILS)
6440	20	VE	BWCYL2A	6	1	N MILS	BORE WEAR CYLINDER 2 AVERAGE (MILS)
6450	20	VE	BWCYL3T	6	1	N MILS	BORE WEAR CYLINDER 3 TOP (MILS)
6460	20	VE	BWCYL3M	6	1	N MILS	BORE WEAR CYLINDER 3 MIDDLE (MILS)
6470	20	VE	BWCYL3B	6	1	N MILS	BORE WEAR CYLINDER 3 BOTTOM (MILS)

FIG. A14.12 Data Dictionary

2-sep-1997

Report: ASTM Data Dictionary

<u>Sequence</u>	<u>Form</u>	<u>Test Area</u>	<u>Field Name</u>	<u>Field Length</u>	<u>Decimal Size</u>	<u>Data Type</u>	<u>Units/Format</u>	<u>Description</u>
6480	20	VE	BWCYL3A	6	1	N	MILS	BORE WEAR CYLINDER 3 AVERAGE (MILS)
6490	20	VE	BWCYL4T	6	1	N	MILS	BORE WEAR CYLINDER 4 TOP (MILS)
6500	20	VE	BWCYL4M	6	1	N	MILS	BORE WEAR CYLINDER 4 MIDDLE (MILS)
6510	20	VE	BWCYL4B	6	1	N	MILS	BORE WEAR CYLINDER 4 BOTTOM (MILS)
6520	20	VE	BWCYL4A	6	1	N	MILS	BORE WEAR CYLINDER 4 AVERAGE (MILS)
6530	20	VE	CYLBWAVG	6	1	N	MILS	BORE WEAR CYLINDER AVERAGE (MILS)
6540	20	VE	CYLBWMAX	6	1	N	MILS	BORE WEAR CYLINDER MAXIMUM (MILS)
6550	21	VE	OILINDP	5	1	N	%	ENGINE OIL INLET TEMP CAL DEV PERCENT (PERCENT)
6560	21	VE	COLOUTDP	5	1	N	%	ENGINE COOLANT OUTLET TEMP CAL DEV (PERCENT)
6570	21	VE	TIMNGDP	5	1	N	%	TIMING CAL DEV (PERCENT)
6580	21	VE	EXO212DP	5	1	N	%	EXHAUST GAS OXYGEN-STAGES 1&2- CAL DEV (PERCENT)
6590	21	VE	EXCO3DP	5	1	N	%	EXHAUST GAS CARBON MONOXIDE-STAGE 3- (PERCENT)
6600	21	VE	COLFLODP	5	1	N	%	ENGINE COOLANT FLOW CAL DEV (PERCENT)
6610	21	VE	RACINDP	5	1	N	%	RAC INLET TEMP CAL DEV (PERCENT)
6620	21	VE	RPMDP	5	1	N	%	ENGINE SPEED CAL DEV (PERCENT)
6630	21	VE	PWRDP	5	1	N	%	POWER CAL DEV (PERCENT)
6640	21	VE	RACCOLDP	5	1	N	%	RAC COOLANT FLOW RATE CAL DEV (PERCENT)
6650	21	VE	EXBK12DP	5	1	N	%	EXHAUST BACKPRESSURE-STAGES 1&2- CAL DEV (PERCENT)

FIG. A14.13 Data Dictionary

```
#####
#
#           Data Dictionary Repeating           #
#           Field Specifications               #
#
#####
# The following contains specifications and field groupings for fields in the
# Data Dictionary that are REPEATING Fields.  These fields can be identified
# in the Data Dictionary by the Hxxx or Rxxx in the last four positions of the
# field name.
#
# Repeating fields are used to specify repeating measurements.
#
# The format for a repeating field name is 4 descriptive characters followed
# by the letter H or R followed by 3 characters for the actual interval
# the measurement was taken. The field will always be a total of 8 characters.
#
# Example ABCDHxxx.
#
# The following is the format of this specification:
#
# Column 1 - 8:   Repeating Field Name
# Column 10 - 17: The Parent Field Name of the Group
# Column 19 - 80: Comments about the Repeating Field Group.
#
# The lines following the Repeating Field Name Record will contain the required
# measurements for the particular field.  Multiple 80 character lines
# can be specified.  A blank line marks the end of each specification.
#
# The Field Name in Column 10-17 designates the the Group in which the field
# belongs.  The First field name in a group is the Parent of the grouping
# and can be used to determine how fields should be grouped.
# The changing of the Parent Field marks the end of a repeating group
# specification.
#
# Example:
#
# VIS_Hxxx, DVISHxxx and PVISHxxx expanded for transmission (8 and 16 hours):
#
#           VIS_H008
#           DVIŠH008
#           PVISH008
#           VIS_H016
#           DVIŠH016
#           PVISH016
#
# Note:  During electronic transmission, repeating field groups must be kept
# together with in the specified group but the order with in the group
# does not have to be maintained.
#
#####
#           Start of Field Grouping Specifications           #
#####
#
VE VERSION 19970902
ITEMHxxx ITEMHxxx  OPERATIONAL DATA ITEM
```

REMKHxxx ITEMHxxx OPERATIONAL DATA REMARKS OR DEVIATIONS

FIG. A14.14 Repeating Field Specifications

TYPEHxxx	TYPEHxxx	SHUTDOWN TYPE
TESTHxxx	TYPEHxxx	TEST HOURS (HHH:MM)
STGEHxxx	TYPEHxxx	STAGE
DTIMHxxx	TYPEHxxx	DOWNTIME TIME (HHH:MM)
LSTMHxxx	TYPEHxxx	LOST TIME (HHH:MM)
DREAHxxx	TYPEHxxx	DOWNTIME PROBLEMS/ACTIONS/COMMENTS
FE_Hxxx	FE_Hxxx	IRON HOURS (PPM)
012 108 204	288 NEW	
CU_Hxxx	FE_Hxxx	COPPER HOURS (PPM)
012 108 204	288 NEW	
SI_Hxxx	FE_Hxxx	SILICON HOURS (PPM)
012 108 204	288 NEW	
VS40Hxxx	FE_Hxxx	VISCOSITY @ 40 DEG C HOURS (CST)
012 108 204	288 NEW	
FUE LHxxx	FE_Hxxx	FUEL DILUTION HOURS (% MASS)
012 108 204	288	
PENTHxxx	FE_Hxxx	PENTANE INSOLUBLES HOURS (% VOLUME)
108 204 288		
OILCHxxx	OILCHxxx	OIL CONSUMPTION CYCLE XXX (FL. OZ.)
006 012 018 024 030	036 042 048 054 060 066 072	
OILLHxxx	OILCHxxx	OIL LEVEL CYCLE XXX (FL. OZ.)
006 012 018 024 030	036 042 048 054 060 066 072	

FIG. A14.15 Repeating Field Specifications

 *
 * When transmitting this Data Dictionary, a Header Data Dictionary should *
 * precede the data. The latest version of this Header Data Dictionary can *
 * be obtained from the Test Monitoring Center either by ftp (internet) or *
 * by calling the Test Engineer responsible for this particular test. *
 *

FIG. A14.16 Header Data Dictionary

A15. ONE-HALF MILLIMETRE OVERSIZE PISTON MODIFICATIONS

A15.1 See Fig. A15.1.

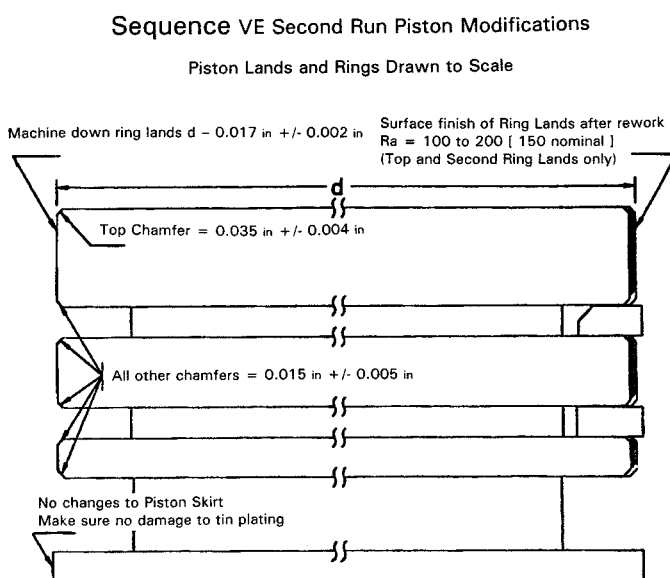

FIG. A15.1 One-half Millimetre Oversize Piston Modifications

A16. REQUIRED INSPECTIONS AND OPERATIONS FOR REUSE OF CYLINDER HEADS

A16.1 Cylinder heads may be reused more than once, provided the head remains within the specifications in Table A16.1. Replacement part numbers and part number for the suggested cam bearing tool are listed in Table A16.1.

A16.2 *Cleaning Process:*

A16.2.1 Remove the cam bearing galley plugs.

A16.2.2 Soak the cylinder head in agitated organic solvent (see 7.7.3), or other approved solvent, until all sludge is dissolved. As an alternative, the head may be cleaned, using a caustic cleaning solution followed by a 1-h soak in agitated organic solvent.

A16.2.3 Rinse the cylinder head in tri-sodium phosphate/hot water bath.

A16.2.4 Spray the cylinder head with a solution of aliphatic naphtha and 50 % Mobile EF-411.

A16.2.5 Dry the cylinder head with forced air.

A16.2.6 Check the cylinder head for flatness (no machining

allowed). Scrap any cylinder head that does not meet the flatness requirements listed in Table A16.1.

A16.2.7 Measure the diameter of the valve guide bores. The valve guides may be reamed, or bored, to use 0.0015-in. diameter oversize Ford valves, if necessary, to maintain specified stem to guide clearance. Scrap any cylinder heads that do not meet the valve guide diameter clearances specified in Table A16.1 with standard or oversize valve stems.

A16.3 *Rebuilding Method:*

A16.3.1 Remove any remaining combustion chamber deposits by using a rotary wire brush.

A16.3.2 Recondition the valve seats. Lapping the valve seats is the preferred method of valve seat reconditioning. Lapping results in an insignificant amount of metal being removed, thus having little if any effect on the installed valve spring height (see 7.8.8.4). Seats may be ground, providing the installed valve spring height and combustion chamber volume

TABLE A16.1 Sequence VE Cylinder Head Specifications and Required Part Numbers

Specifications	
Combustion chamber volume	59.8-62.8 cm ³
Valve guide bore diameter	0.3433-0.3443 in. (8.72-8.75 mm)
Valve stem to guide clearance:	
Intake	0.0014-0.0027 in. (0.035-0.069 mm)
Exhaust	0.0019-0.0032 in. (0.048-0.081 mm)
Valve springs:	
Free length	1.9-2.0 in. (48.3-50.8 mm)
Out-of-square	0.075-in. max (1.91 mm)
Compression force	167 ± 8 lbf at 1.16 ± 0.03 in. (743 ± 36 N at 29.5 ± 0.76 mm)
Installed height	1.53-1.59 in. (38.86-40.39 mm)
Intake and exhaust valve seat angle	45°
Intake valve seat width	0.060-0.080 in. (1.52-2.03 mm)
Exhaust valve seat width	0.070-0.090 in. (1.78-2.29 mm)
Seat runout limit (T.I.R. max)	0.0016 in. (0.041 mm)
Flatness, cylinder head deck (no machining allowed)	0.006 in. max (0.15 mm)
Ford part numbers:	
Cam bearings	D4FZ-6261-C
Camshaft oil seal	E8ZZ-6700-A
Intake valve	E8ZZ-6507-A
Intake valve (0.0015 in. oversize)	E8ZZ-6507-B
Exhaust valve	E43Z-6505-A
Exhaust valve (0.0015 in. oversize)	E43Z-6505-B
Cam bearing tool (suggested)	T71P-6250-A
Expander screw (not supplied with tool)	T65L-6250-A13

comply with the values specified in Table A16.1.

A16.3.3 Clean with aliphatic naphtha spray, and use bristle brushes on the combustion chambers and valve deck and through the valve guides. Final spray with aliphatic naphtha containing 50 % Mobile EF-411.

A16.3.4 Dry with forced air.

A16.3.5 Install new cam bearings. Any method of installation may be used that ensures free movement of the camshaft.

A16.3.6 Install new camshaft oil seal.

A16.3.7 Assemble the cylinder head in accordance with 7.8.6 of this test method. Use new intake and exhaust valves, and lubricate all parts with Mobil EF-411.

APPENDIXES

(Nonmandatory Information)

X1. ENGINE MEASUREMENT SHEETS

X1.1 See Figs. X1.1-X1.6.

pages are recommended to be utilized in accordance with the requirements of 7.8.6-7.8.15.

NOTE X1.1—The data sheets shown sequentially on the following

SEQUENCE VE
CYLINDER BORE, PISTON, AND COMPRESSION RING MEASUREMENTS

Engine No. _____
Engine Build No. _____
Date _____
Technician _____

Cylinder Bore Measurements

Cylinder Number	Location	Longitudinal Diameter (LD), in.	Transverse Diameter (TD), in.	Average Bore Diameter (ABD), in. $\frac{TD @ mid + TD @ bot}{2}$	Bore Out of Round, in. [LD - TD] (0.0010) max	Bore Taper, in. (max Δ) (0.001 max)	Microfinish, μin.
1	Top						
	Middle						
	Bottom						
2	Top						
	Middle						
	Bottom						
3	Top						
	Middle						
	Bottom						
4	Top						
	Middle						
	Bottom						

Piston Measurements

Cylinder Number	Range of Acceptable Piston Diameter, in. (ABD - 0.0014 to ABD + 0.0022 in.)	Diameter of Selected Piston, in.	Taper of Selected Piston, in.
1			
2			
3			
4			

Compression Ring Gap Measurements

Cylinder Number	Top Ring Gap, in.	Second Ring Gap, in.	Top Ring-Land Side Clearance, in.	Second Ring-Land Side Clearance, in.
1				
2				
3				
4				

Compression Ring Regap History and Wear Data

Cylinder Number	Ring Location	Ring Gap @ _____ hrs, in.	Ring Gap After Rework, in.	Ring Gap @ _____ hrs, in.	Ring Gap After Rework, in.	Ring Gap Increase Due to Wear, in.
1	Top					
	Second					
2	Top					
	Second					
3	Top					
	Second					
4	Top					
	Second					

FIG. X1.1 Bore Piston and Ring Measurement Data

SEQUENCE VE

CYLINDER BORE, PISTON, AND COMPRESSION RING MEASUREMENTS

Engine No. _____
 Engine Build No. _____
 Date _____
 Technician _____

Cylinder Bore Measurements

Cylinder Number	Location	Longitudinal Diameter (LD), mm	Transverse Diameter (TD), mm	Average Bore Diameter (ABD), mm $\frac{TD @ mid + TD @ bot}{2}$	Bore Out of Round, mm [LD - TD] (0.035) max	Bore Taper, mm (max Δ) (0.038 max)	Microfinish, μm
1	Top						
	Middle						
	Bottom						
2	Top						
	Middle						
	Bottom						
3	Top						
	Middle						
	Bottom						
4	Top						
	Middle						
	Bottom						

Piston Measurements

Cylinder Number	Range of Acceptable Piston Diameter, mm (ABD - 0.036) to (ABD - 0.056)	Diameter of Selected Piston, mm	Taper of Selected Piston, mm
1			
2			
3			
4			

Compression Ring Gap Measurements

Cylinder Number	Top Ring Gap, mm	Second Ring Gap, mm	Top Ring-Land Side Clearance, mm	Second Ring-Land Side Clearance, mm
1				
2				
3				
4				

Compression Ring Regap History and Wear Data

Cylinder Number	Ring Location	Ring Gap @ ____ hrs, mm	Ring Gap After Rework, mm	Ring Gap @ ____ hrs, mm	Ring Gap After Rework, mm	Ring Gap Increase Due to Wear, mm
1	Top					
	Second					
2	Top					
	Second					
3	Top					
	Second					
4	Top					
	Second					

FIG. X1.1 (M) Bore Piston and Ring Measurement Data (continued)

SEQUENCE VE

CRANKSHAFT, OIL PUMP, CONNECTING ROD, AND CAMSHAFT ENDPLAY MEASUREMENTS

Engine No. _____
 Engine Build No. _____
 Camshaft No. _____
 Date _____
 Technician _____

Crankshaft Measurements
 Main Bearing Journals

Journal Number	Horizontal Diameter (HD) (HD), in. (2.3982 – 2.3990 in.) (60.91 – 60.94 mm)	Vertical Diameter (VD) (VD), in.	Out of Round (VD – HD), in. (0.0006 in. max) (0.015 mm)	Fitted Bearing Clearance, in. (0.0008 – 0.0026 in.) (0.020 – 0.066 mm)
1				
2				
3				
4				
5				

Crankshaft Measurements
 Rod Bearing Journals

Journal Number	Horizontal Diameter (HD) (HD), in. (2.0464 – 2.0472 in.) (51.98 – 52.00 mm)	Vertical Diameter (VD) (VD), in.	Out of Round (VD – HD), in. (0.0006 in. max) (0.015 mm max)	Fitted Bearing Clearance, in. (0.0008 – 0.0026 in.) (0.020 – 0.066 mm)
1				
2				
3				
4				

Connecting Rod Oil Orifice Diameter

Connecting Rod Number	Oil Orifice Diameter (0.062 – 0.068 in.) (1.57 – 1.73 mm)
1	
2	
3	
4	

Camshaft Endplay

Endplay (0.001 – 0.007 in.) (0.03 – 0.18 mm)

FIG. X1.2 Crankshaft Bearing Clearance, and Miscellaneous Measurement Data

SEQUENCE VE

CAMSHAFT DIMENSIONAL MEASUREMENTS

Camshaft No. _____
 Engine No. _____
 Engine Build No. _____
 Date _____
 Technician _____

Camshaft Lobe Height (1.4150 – 1.4228 in.) (35.94 – 36.14 mm)			
Lobe Location	Height Before Test, (BH), in.	Height After Test, (AH), in.	Difference (BH – AH), in.
1E			
1I			
2E			
2I			
3E			
3I			
4E			
4I			
Average Difference _____			
Maximum Difference _____			

Camshaft Lobe Oil Orifice Diameter (0.047 – 0.055 in.) (1.19 – 1.40 mm)	
Lobe	Orifice Diameter
1E	
1I	
2E	
2I	
3E	
3I	
4E	
4I	

Camshaft Journal Oil Orifice Diameter (0.116 – 0.124 in.) (2.95 – 3.15 mm)	
Journal	Orifice Diameter
Front	
Rear	

Camshaft Oil Delivery Groove Dimensions		
	Groove Depth (0.039 – 0.047 in.) (0.99 – 1.19 mm)	Groove Width (0.052 – 0.063 in.) (1.32 – 1.60 mm)
Front		
Rear		

FIG. X1.3 Camshaft Measurement Data

SEQUENCE VE

CAMSHAFT LOBE AND ROCKER ARM HARDNESS

Engine No. _____
 Engine Build No. _____
 Camshaft No. _____
 Date _____
 Technician _____

Lobe Location	Lobe Hardness (>50 Rockwell C)	Rocker Arm Hardness (>57 Rockwell C)
1E		
1I		
2E		
2I		
3E		
3I		
4E		
4I		

NOTE 1—Camshafts with individual lobe hardness less than 50 Rockwell C may be used. Record lobe location(s) and hardness value(s) on the Supplemental Operational Data form, see Fig. A7.5.

FIG. X1.4 Hardness Measurement Data

SEQUENCE VE
CONNECTING ROD BEARING AND
ROCKER ARM WEIGHT

Engine No. _____
 Engine Build No. _____
 Camshaft No. _____
 Set No. _____
 Date _____
 Technician _____

Connecting Rod Bearing Weight

Connecting Rod Number	Bearing Location	Weight Before Test (WB), g	Weight After Test (WA), g	Weight Loss (WB - WA), mg	Total Weight Loss (Top + Bottom), mg
1	Top				
	Bottom				
2	Top				
	Bottom				
3	Top				
	Bottom				
4	Top				
	Bottom				

Rocker Arm Weight

Rocker Arm Location	Weight Before Test (BW), mg	Weight After Test (AW), mg	Difference (BW - AW), mg
1E			
1I			
2E			
2I			
3E			
3I			
4E			
4I			

Average Difference _____
 Maximum Difference _____

FIG. X1.5 Weight Measurement Data

SEQUENCE VE

Engine No. _____
 Engine Build No. _____
 Head No. _____
 Date _____
 Technician _____

VALVE SPRING MEASUREMENTS

Spring Location	Free Length, in. (1.9 - 2.0 in.) [48.3 - 50.8 mm]	Out of Square, in. (0.078 in. max) [1.98 mm max]	Force	
			Uninstalled (167 ± 8 lbf @ 1.16 ± 0.03 in.) [75.7 ± 3.6 kgf @ 29.5 ± 0.8 mm]	Installed (167 ± 8 lbf)
1E				
1I				
2E				
2I				
3E				
3I				
4E				
4I				

VALVE STEM TO GUIDE CLEARANCE

Valve Location	Valve Guide Diameter (GD), in.	Valve Stem Diameter (SD), in.	Stem to Guide Clearance (GD - SD), in.
			Exhaust (0.0019 - 0.0032 in.) [0.048 - 0.081 mm] Intake (0.0014 - 0.0027 in.) [0.035 - 0.068 mm]
1E			
1I			
2E			
2I			
3E			
3I			
4E			
4I			

FIG. X1.6 Cylinder Head Measurement Data

X2. SOURCES OF MATERIALS AND INFORMATION

X2.1 The following sources are provided for convenience only. This does not represent an exclusive or complete listing of required materials or information sources.

X2.1.1 *ASTM Sequence VE Test Parts*—ASTM Sequence VE Test Parts Kits can be purchased through Ford Power Products distributors and Ford or Lincoln-Mercury dealers. The distributor or dealer should transmit orders to the address following:

Ford Parts and Service Division
Power Products Operations
3000 Schaefer Road
P.O. Box 6011
Dearborn, MI 48121

X2.1.2 *ASTM Test Monitoring Center*—All communications with the TMC should be directed as follows:

ASTM Test Monitoring Center
4400 Fifth Ave.
Pittsburgh, PA 15213

X2.1.3 *Test Sponsor*— All communications with the test sponsor (Ford Motor Company) should be directed as follows:

Ford Motor Co.
EEE Bldg., Room D-145 (Box 44)
21500 Oakwood Blvd.
Dearborn, MI 48121-2053

X2.1.4 *Aeroquip Hose and Fittings*—Aeroquip hose and fittings can be obtained from the following supplier:

Aeroquip Corp.
1225 W. Main
Van Wert, OH 45891

X2.1.5 *Inspected Engine Parts*—Premeasured and calibrated Sequence VE engine parts and various component calibration devices are available from the following supplier:

Test Engineering Inc.
1530 Larkspur Drive
San Antonio, TX 78213

X2.1.6 *Fuel Information*—General information concerning Phillips J fuel can be obtained from the following:

Phillips Petroleum Co.
3C3 Home Savings and Loan Building
Bartlesville, OK 74004

X2.1.6.1 *Fuel Availability*—Phillips J Reference Gasoline is available from the following supplier:

Phillips Chemical Co.
Speciality Chemicals
P.O. Box 968
Borger, TX 79008-0968

X2.1.7 *Water-Cooled Exhaust Manifolds*—The exhaust manifold is available from the following supplier:

Edelbrock Inc.
2700 California St.
Torrance, CA 90503

X2.1.8 *Engine Coolant Flowmeter*—Barco flowmeters for the engine coolant system (PN BR 12705-16-310) can be obtained from the following supplier:

Aeroquip Corp.
1225 W. Main
Van Wert, OH 45891

X2.1.9 *Intake-Air Humidity Instruments*—The Alnor Dewpointer, EG & G, Foxboro, and Protimeter dewpoint meters (or equivalent) are suitable for measurement of the intake-air specific humidity.

X2.1.10 *Blowby Flow Rate Orifice*—Information concerning the blowby flow rate orifice meter is available from the following:

General Motors Research Laboratories
Fuels and Lubricants Dept.
30500 Mound Road
Warren, MI 48090-9055

X2.1.11 *Heat Exchangers*— ITT Standard and Ross Heat Exchangers can be obtained from the following supplier:

Kinetics Engineering Corp.
2055 Silber Road, Suite 101
Houston, TX 77055

X2.1.12 *Fuel Flow Measurement*—Mass fuel flowmeters are available from the following supplier:

Micro Motion Corp.
7070 Winchester Circle
Boulder, CO 80301

X2.1.13 *Various Materials*—RAC kits, oil separators, camshaft baffles, oil filter adapters SB3 and EB3, and various other test stand parts and component calibration devices utilized in this test method are available from the following supplier:

Bowden Manufacturing Corp.
4590 Beidler Road
Willoughby, OH 44094

X2.1.14 *Fuel Management Systems*—Fuel management systems are available from the following supplier:

Intelligent Controls, Inc.
41000 Vincenti Court
Novi, MI 48050

X2.1.15 *Exhaust Gas Analysis Instrumentation*—Exhaust gas analysis instrumentation can be obtained from the following suppliers:

X2.1.15.1 *CO Measurement (0 to 10 % CO)*—Beckman Model 864 or 868 is available from:

Rosemont
12001 W. Technology Drive
Eden Prairie, MN 55344

X2.1.15.2 *CO Measurement (0 to 10 % CO)*—Horiba PIR 2000 is available from:

Horiba Inc.
1021 Duryea
Irvine, CA 92714

X2.1.15.3 *O₂ Measurement*—Beckman Model 715 Process Oxygen Monitor is available from:

Rosemont
12001 W. Technology Drive
Eden Prairie, MN 55344

X2.1.15.4 *O₂ Measurement*—Scott Oxygen Analyzer Model 250 is available from:

Environmental Tectonics Corp.
Countyline Industrial Park
South Hampton, PA 18966

X2.1.15.5 *O₂ Measurement*—Teledyne 320 B/RC is available from:

Teledyne Analytical Instruments, Inc.
16830 Chestnut St.
Industry, CA 91749

X2.1.15.6 *NO_x Measurement*—Beckman Model 951 is available from:

Rosemont
12001 W. Technology Drive
Eden Prairie, MN 55344

X2.1.15.7 *UEGO Sensors are available from:*

NGK Spark Plugs
27260 Haggerty Road
Suite A-14
Farmington Hills, MI 41018

X2.1.16 *Exhaust Gas Analysis Calibration Gases*—Calibration gases for exhaust gas analysis equipment can be obtained from the following supplier:

Scott Environmental Technology, Inc.
Route 611
Plumbsteadville, PA 18949

X2.1.17 *Crankcase and Intake-Air Pressure Gages*—Gages are available from the following supplier:

Dwyer Instrument Co.
Junction of Indiana State Highway 212 and U.S. Highway 12
P.O. Box 373
Michigan City, IN 46360

X2.1.18 *Condensate Trap*—Meriam Model 932S condensate trap is available from the following supplier:

Meriam Instrument
10920 Madison Ave.
Cleveland, OH 44102

X2.1.18.1 *Condensate Traps*—Norgren miniature filter/line traps have been found suitable and are available from the following supplier:

C. A. Norgren Co.
1 Norgren Plaza
Littleton, CO 80120-1698

X2.1.19 *Cooling System Flushing Agent*—Formulation No. 7 Cooling System Cleanser—Heavy-Duty is available from a division of the following supplier:

Aarmorall Products Corp.
Aliso Viejo, CA 92656

X2.1.20 *Lubricants*—EF-411 and Vacmul 3-D are available from local distributors of Mobil products.

X2.1.21 *Piston Ring Grinder*—A Sanford Piston Ring Grinder has been found satisfactory and is available from the following supplier (purchasers should specify the Ford 2.3 L engine application):

Sanford Manufacturing Co.
300 Cox Street
P.O. Box 318
Roselle, NJ 07203

X2.1.22 *Hardness Tester*—A suitable hardness tester is available from the following supplier:

King Tester Corp.
510 Feheley Drive
King of Prussia, PA 19406

X2.1.23 *Connecting Rod Heater*—The Sunnen Model CRH-50 connecting rod heater has been found suitable and is available from the following supplier:

Sunnen Inc.
7910 Manchester
St. Louis, MO 63143

X2.1.24 *Tygon Hose*—Tygon hose is available through local Cadillac Plastic Company distributors or the following supplier:

The Norton Co.
12 East Avenue
Tallmadge, OH 44278

X2.1.25 *Rating Lamps*—Suitable rating lamps are available from the following supplier:

Dazor Manufacturing Corp.
4455 Duncan Ave.
St. Louis, MO 63110

X2.1.26 *Valve Springs*—Additional valve springs are available from the following supplier:

Associated Spring Co.
401 Stadium Drive
Ann Arbor, MI 40810

X2.1.27 *Special Tools for the Test Engine*—Special tools to facilitate assembly and disassembly of the engine are available from the following supplier:

Owatonna Tool Co.
2013 4th St. NW
Owatonna, MN 55060

X2.1.28 *Cylinder Head Stress Plate*—A stress plate, which in conjunction with the laboratory supplied stress plate (see Section 7.5.9 and Fig. A3.36) is designed to simulate the cylinder head, is available from the following supplier:

BHJ Products
37530 Enterprise Ct.
Newark, CA 94560
(Reference No: 38413)

X2.1.29 *Remote Oil Filter Adapter*—A remote filter adapter, Part No. OHTA-007-1 is available from the following supplier:

OH Technologies
P.O. Box 5039
Mentor, OH 44061-5039

X3. ANALYSIS OF PHILLIPS J FUEL, BATCH 26

X3.1 See Table X3.1.

TABLE X3.1 Analysis of Phillips J Fuel, Batch 26

API Gravity at 60°F (16°C)	54.6
Color	Undyed
Doctor test	Negative
Copper corrosion, 3 h at 212°F (100°C)	1-A
Reid vapor pressure, psig (kPa)	8.0 (55)
Research octane number	94.2
Motor octane number	83.0
$\frac{\text{Research} + \text{Motor}}{2} [(R + M)/2]$	88.6
Total sulfur, % weight	0.019
Gum, mg/100 mL	0.4
Oxidation Stability, min	1200 +
Lead, g/gal (mg/L)	<0.001 (<0.26)
Distillation, % Evaporation, ° F (°C)	
IBP	98 (37)
10 %	130 (54)
50 %	225 (107)
90 %	335 (168)
End point	425 (218)
Recovery, %	98
PONA, % vol	
Paraffins plus Napthenes	43.5
Olefins	14.7
Aromatics	41.8

**X4. THEORETICAL EXHAUST GAS RELATIONSHIPS)
PHILLIPS J REFERENCE FUEL**

X4.1 See Fig. X4.1.

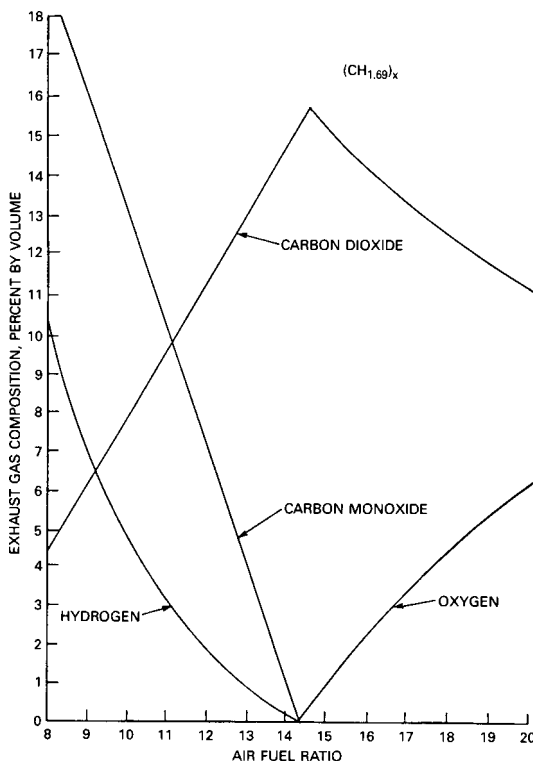

FIG. X4.1 Theoretical Exhaust Gas Relationships, Phillips J Reference Fuel

X5. DESCRIPTION OF SCOTT QUARTERLY GAS AUDIT SERVICE

X5.1 The Scott Quarterly Gas Audit Service is a subscription service to audit the performance of CO and O₂ analysis instruments and is offered by Scott environmental Technology (see X2.1.16). The service is completed once every three months and utilizes span gases of CO and O₂ in a balance of N₂. The exact concentration of the span gases is unknown to the customer, but falls within a specified range.

X5.2 The subscriber analyzes the span gas with the instrumentation used for VE testing. The gas is introduced through the calibration port and the sample inlet of the system. The laboratory submits the results to Scott, and Scott publishes

a report detailing individual results and a statistical analysis using data from all participating laboratories.

X5.3 Differences in results obtained at the sample port and the calibration inlet normally result from operating procedures, leaks in the sampling system, or improper design of the sampling system. Differences in results between a specific laboratory and the industry average usually indicate deficiencies in the analyzer or the quality of the calibration gases.

X5.4 Calibration gases traceable to national standards can also be utilized to verify the performance of exhaust gas analysis equipment.

The American Society for Testing and Materials takes no position respecting the validity of any patent rights asserted in connection with any item mentioned in this standard. Users of this standard are expressly advised that determination of the validity of any such patent rights, and the risk of infringement of such rights, are entirely their own responsibility.

This standard is subject to revision at any time by the responsible technical committee and must be reviewed every five years and if not revised, either reapproved or withdrawn. Your comments are invited either for revision of this standard or for additional standards and should be addressed to ASTM Headquarters. Your comments will receive careful consideration at a meeting of the responsible technical committee, which you may attend. If you feel that your comments have not received a fair hearing you should make your views known to the ASTM Committee on Standards, at the address shown below.

 **D 5302**

This standard is copyrighted by ASTM, 100 Barr Harbor Drive, PO Box C700, West Conshohocken, PA 19428-2959, United States. Individual reprints (single or multiple copies) of this standard may be obtained by contacting ASTM at the above address or at 610-832-9585 (phone), 610-832-9555 (fax), or service@astm.org (e-mail); or through the ASTM website (www.astm.org).