



Standard Test Method for Evaluating the Thermal Stability of Manual Transmission Lubricants in a Cyclic Durability Test¹

This standard is issued under the fixed designation D 5579; the number immediately following the designation indicates the year of original adoption or, in the case of revision, the year of last revision. A number in parentheses indicates the year of last reapproval. A superscript epsilon (ϵ) indicates an editorial change since the last revision or reapproval.

1. Scope

1.1 This test method covers the thermal stability of fluids for use in heavy duty manual transmissions when operated at high temperatures.

1.2 The lubricant performance is measured by the number of shifting cycles that can be performed without failure of synchronization when the transmission is operated while continuously cycling between high and low range.

1.3 Correlation of test results with truck transmission service has not been established. However, the procedure has been shown to appropriately separate two transmission lubricants, which have shown satisfactory and unsatisfactory field performance in the trucks of one manufacturer.

1.4 Changes in this test method may be necessary due to refinements in the procedure, obsolescence of parts, or reagents, and so forth. These changes will be incorporated by Information Letters issued by the ASTM Test Monitoring Center (TMC).² The test method will be revised to show the content of all the letters, as issued.

1.5 The values stated in inch-pound units are to be regarded as standard. When materials, products, or equipment are available only in inch-pound units, SI units are omitted.

1.6 *This standard does not purport to address all of the safety concerns, if any, associated with its use. It is the responsibility of the user of this standard to establish appropriate safety and health practices and determine the applicability of regulatory limitations prior to use.*

1.7 This test method is arranged as follows:

	Section
Scope	1
Referenced Documents	2
Terminology	3
Summary of Test Method	4
Significance and Use	5
Apparatus	6
Test Transmission	6.2
Transmission Mounts	6.3
Oil-Circulating System	6.4
Oil Return Hole	6.5
Air Pressure Controls	6.6
Drive System	6.7
Instrumentation	6.8
Thermocouple Placement	6.9
Reagents and Materials	7
Safety	8
Preparation of Apparatus	9
Cleaning of Parts	9.1
Assembly	9.2
Calibration	10
Transmission and Test Stand Calibration	10.1
Reference Oils	10.2
Reference Oil Test Frequency	10.3
Instrumentation Calibration	10.4
Shift Time Calibration	10.5
Operating Procedure	11
System Flush and Charge	11.1
Test Operation	11.2

¹ This test method is under the jurisdiction of ASTM Committee D02 on Petroleum Products and Lubricants and is the direct responsibility of Subcommittee D02.B0 on Automotive Lubricants.

Current edition approved May 10, 2003⁴. Published June 2003⁴. Originally approved in 1994. Last previous edition approved in 2004³ as D 5579⁺ – 04³.

² ASTM Test Monitoring Center, 6555 Penn Ave., Pittsburgh, PA 15206-4489. This edition incorporates revisions in all Information Letters through No. 023-1.

Shut-Down Procedure	11.3
Transmission Disassembly	11.4
Determination of Test Results	12
Failure Criteria	12.1
Shifter Fork Wear	12.2
Test Validity Determination	12.3
Report	13
Precision and Bias	14
Keywords	15
Test Validity Calculations and Limits	Annex A1
Test Kit Parts	Annex A2
Report Forms	Annex A3 Data Dictionary
<u>HTCT Test Report Forms and Data Dictionary</u>	Annex A3 Data Dictionary
<u>Manual Transmission Cyclic Durability Test Parts Inspection and Wear Measurements</u>	Annex A5
<u>Manual Transmission Cyclic Durability Test Parts Inspection and Wear Measurements</u>	Annex A4

2. Referenced Documents

2.1 ASTM Standards:³

D 235 Specification for Mineral Spirits (Petroleum Spirits) (Hydrocarbon Dry Cleaning Solvent)

2.2 SAE Standard:

SAE J308 Axle and Manual Transmission Lubricants⁴

2.3 Military Standard:

MIL-L-2105 Lubricating Oil, Gear, Multipurpose⁵

2.4 Other Standard:

GO-H Mack Trucks Oil, Gear: Multi-Purpose⁶

3. Terminology

3.1 Definitions:

3.1.1 *wear*—the loss of material from two or more surfaces in relative motion.

3.2 Definitions of Terms Specific to This Standard:

3.2.1 *dual-range transmission*—a type of transmission in which the driver first shifts through all of the mainbox gear ratios in low range, and then shifts to high range and shifts through the mainbox again. The section containing the high-low range is the compound section.

3.2.2 *friction disk*—a steel circular plate to which a friction material has been bonded.

3.2.3 *glazed*—the condition of the friction disks when precipitates have filled the pores in the friction material, polishing the surface, and changing the frictional properties.

3.2.4 *reaction disk*—a steel disk that mates with the friction disk during synchronization.

3.2.5 *shift time*—the period of time required for the countershaft speed to increase from 500 to 700 r/min (high-to-low) or from 1700 to 500 r/min (low-to-high) shift.

3.2.6 *synchronizer*—a pack of friction and reaction plates used to match the speeds of the low- and high-range gears prior to engagement.

3.2.7 *unsynchronized shift*—a shift in which the speed of the mating gears is not matched to the speed of the transmission output shaft by the synchronizer.

4. Summary of Test Method

4.1 Prior to each test run, the transmission is disassembled and all parts, including the case and the oil-circulating and heating systems, are thoroughly cleaned. The transmission is rebuilt with a new synchronizer assembly, including measured shifter fork, friction, and reaction disks. All other worn or defective parts are replaced.

4.2 The rebuilt transmission is installed on a test stand.

4.3 The transmission and oil system are flushed with the test oil in accordance with the flush procedure.

4.4 The flush oil is drained, and the test oil is measured and charged to the transmission.

4.5 The transmission is started and operated in low range until the oil temperature reaches the test operating range.

4.6 The transmission is automatically cycled between low and high range until two unsynchronized shifts occur or the desired length of test is reached without failure. The time required to shift from high range to low range is recorded each hour.

³ For referenced ASTM standards, visit the ASTM website, www.astm.org, or contact ASTM Customer Service at service@astm.org. For *Annual Book of ASTM Standards*, Vol 06.04, volume information, refer to the standard's Document Summary page on the ASTM website.

⁴ Available from Society of Automotive Engineers (SAE), 400 Commonwealth Dr., Warrendale, PA 15096-0001.

⁵ Available from Standardization Documents Order Desk, DODSSP, Bldg. 4, Section D, 700 Robbins Ave., Philadelphia, PA 19111-5098.

⁶ Available from Mack Trucks, Inc., 13302 Pennsylvania Ave., Hagerstown, MD 21742.

4.7 At the conclusion of the test, the test parts are removed and visually inspected. The shifter fork and friction plates are measured again to determine wear.

5. Significance and Use

5.1 This test method is used to evaluate automotive manual transmission fluids for thermal instability, which results in deterioration of synchronizer performance.

5.2 This test method may also be utilized in other specifications and classifications of transmission and gear lubricants such as the following:

- 5.2.1 (final API designation of PG-1),
- 5.2.2 Military Specification MIL-L-2105,
- 5.2.3 SAE Information Report J308 Axle and Manual Transmission Lubricants, and
- 5.2.4 Mack Truck GO-H Gear Lubricant Specification.

6. Apparatus

6.1 Table 1 is a list of the make and model of recommended instruments and equipment.

6.2 *Test Transmission*—The test transmission is a MACK T2180, configuration 11KBA51431 (see Fig. 1). Some parts in the transmission are to be removed and some are to be added before testing, as listed in Table 2. The main box shift rail cover can be replaced with an aluminum plate to facilitate transmission cleaning at end of test.

6.3 *Transmission Mounts*—The transmission is mounted as shown in Fig. 2.

6.4 *Oil-Circulating System*—The system heats the oil to the specified operating temperature of $250 \pm 5^\circ\text{F}$ ($121 \pm 2.7^\circ\text{C}$) and maintains this temperature throughout the duration of the test. The power density of the heater is not high enough to cause degradation of the oil (22 to 25 W/in.^2 (3.4 to 3.9 W/cm^2)). The oil flow rate is between 6 and 10 gal/min (23 to 38 L/min). A layout of the oil-circulation system is shown in Fig. 3. A detailed drawing of the recommended oil heating chamber is shown in Fig. 4. The total oil capacity of the test system is 5.25 gal (19.87 L) with the oil level in the transmission at the lower edge of the fill hole.

TABLE 1 Recommended Test Stand Components

Item	Manufacturer	Part No.
Panel Meters		
Tailshaft rpm	Newport	P-6031D20D
Countershaft rpm	Newport	P-6031D20D
Shift time	Newport	P-6031D20D
Coast down time	Newport	P-6031D20D
Control Indication		
Temperature controller	Omron	ESEX-AF
Temperature indicator	Newport	INF-0-0-0-0-JF
Cycle counter	Redington	P2-1006-115AC
Cycle timer	Omron	H5BR-B-AC100-240
T/C selector switch	Thermo Electric	33112
Oil psi gage/safety	Murphy	A-20EO, O-30 psi
Air supply gage	U.S. Gage	P44U, O-160 psi
Air regulator	Norgren	RO-8-300 RNMA
Shift solenoid	Asco	8317G35, 3-way solenoid
Mag. pickup	Electro	3010AN
12 VDC Power supply	Sola	SLS-12-017
Air pressure switch	Penn	P61AG-1
Relays—A.C.	Potter & Brumfield	KUP14A15
Relays—AC	Potter & Brumfield	KUP14A15
Relays—D.C.	Potter & Brumfield	KUP14D15
Relays—DC	Potter & Brumfield	KUP14D15
Mechanical Components		
Air lines	Mack	101AX24R, 3/8 in. OD
Pump	Brown & Sharp	No. 2
Heater element	Chromalox	MOT330A, 220v, 1Ph
Oil lines	Aeroquip	EC-350, No. 12
U Joint yoke	Mack	1710 Series, 38MU3413M
Drive shaft	Rockwell	1710 Series, 52 in. collapsed
Drive motor	General Electric	25-hp Induction Motor, 1760 rpm
High-Speed Recording System		
Pressure transducers	Sensotec	A-5/1034, 0-100 psi
Oscillograph	Astro-Med	Dash 4

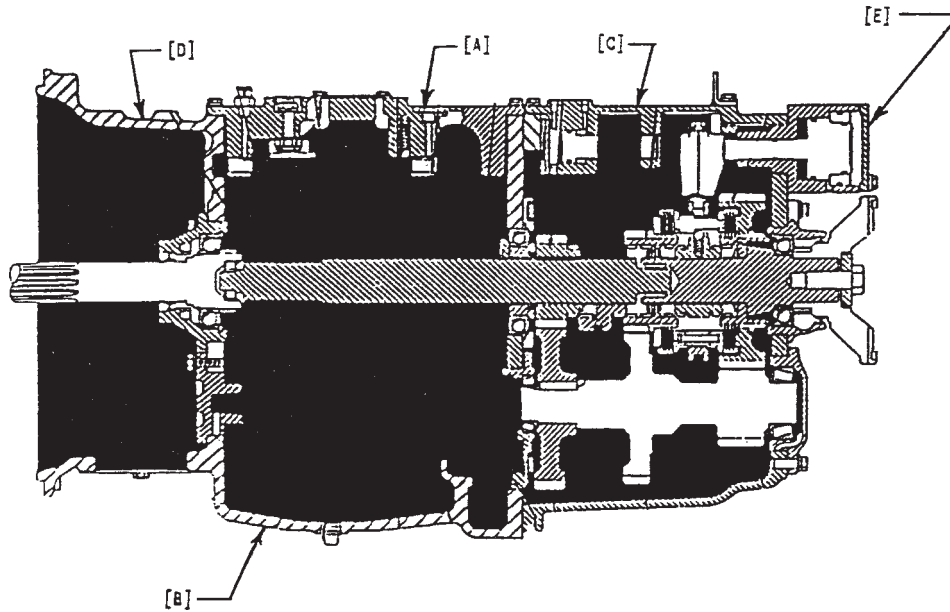

NOTE 1—Left side view.

NOTE 2—See Table 2 for references to letters in brackets.

FIG. 1 Transmission Modified for Testing

TABLE 2 Transmission Parts to Be Added or Removed Before Testing

NOTE—Letters in brackets, [], refer to locations indicated on Fig. 1.

Parts to Be Removed
Rails, forks, springs, and ball from the mainbox shift cover [A]
All main box gesting [B]:
Mainshaft gears and thrust washers
Countershaft assemblies
Sliding clutches (320KB3136, (2)320KB3137A)
Compound [C]
Splitter clutch (320KB3141)
Splitter piston and fork (336KC333, 575KB3378)
Bell Housing [D]
All clutch related parts
Shafts (604KC277A, 604KC34B)
Yoke (301KD43B)
Parts to Be Added
Speedometer plug (37KC12) and washer (37AX419)
Pipe extension, 1/8 NPT and orifice (63AX3466) to Range Valve
Replace cast iron piston housing cover with fabricated steel cover [E]

If the system capacity is too small, increase by lengthening oil hoses. When the system capacity is too great, decrease by shortening hoses, if it is practical to do so; otherwise, install an inert (stainless steel) block in the transmission main box sump to raise the oil level. Route the oil lines so that they will empty completely when draining the system.

6.5 *Oil Return Hole*—A hole shall be drilled and tapped in the compound case for the oil to return after flowing through the heat exchanger. The location and size of this hole are shown in Fig. 5.

6.6 *Air Pressure Controls*—The transmission is shifted by air pressure applied to alternating sides of the range shift piston. The air pressure is provided by a pilot valve, which is cycled by a solenoid valve at a rate of 5 cpm. These cycles are recorded by a counter, which provides the cycles to mis-shift data for the pass/fail criteria of the test. A typical air control system is shown in Fig. 6.

6.7 *Drive System*—In the truck operation, opposing torques help the synchronizer to complete the shift. In the test stand, the transmission is driven from the rear by an electric motor and belt drive with no loading on the input pinion. The torques, therefore, are not present, and shifting can be delayed. To help the synchronizer shift smoothly without the opposing torque, a vibration in the drive line is intentionally excited. The driveline is set out of phase by rotating the yoke at one end of the shaft with respect to the other by a one spline tooth offset (22°). The transmission output shaft is offset from the shaft of the motor or jack shaft,

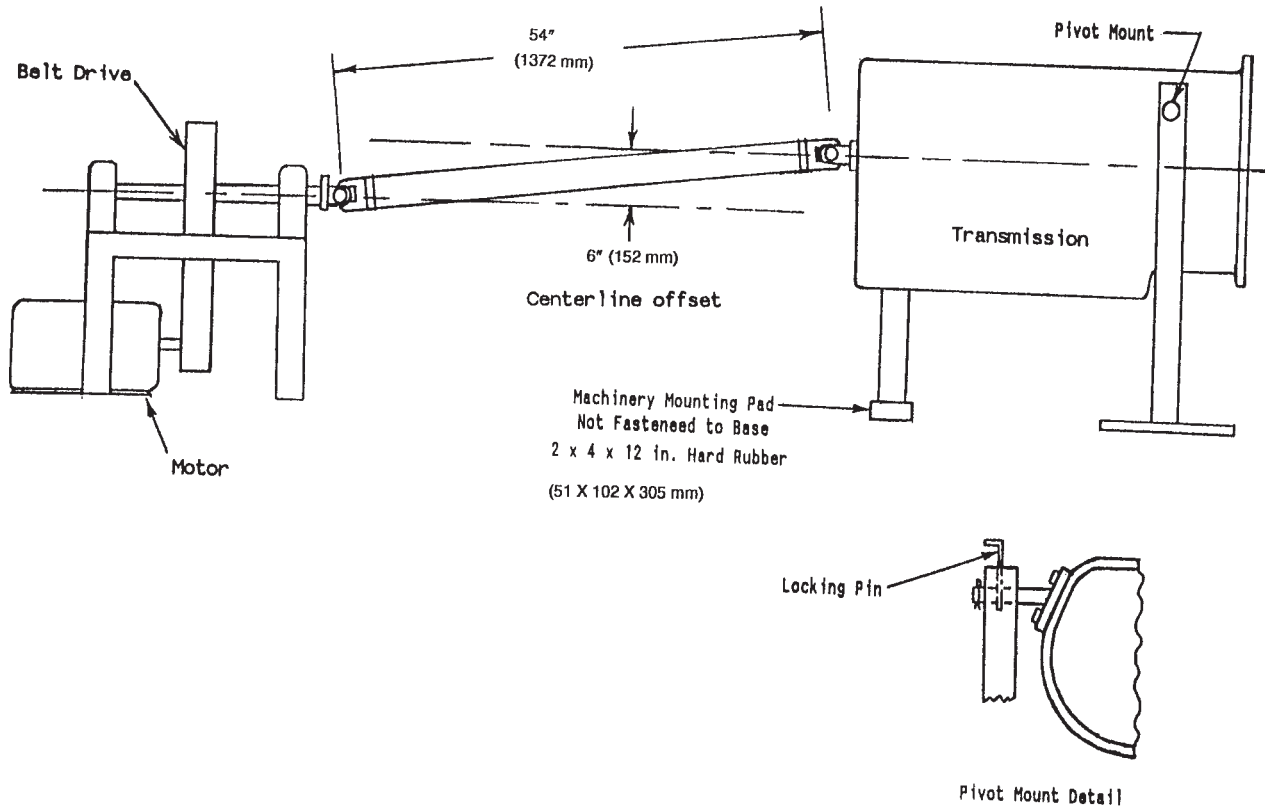

FIG. 2 Typical Layout of Drive System

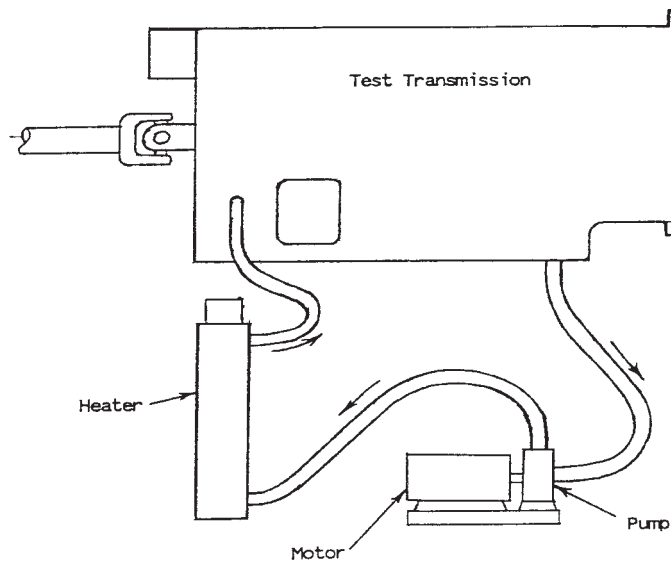
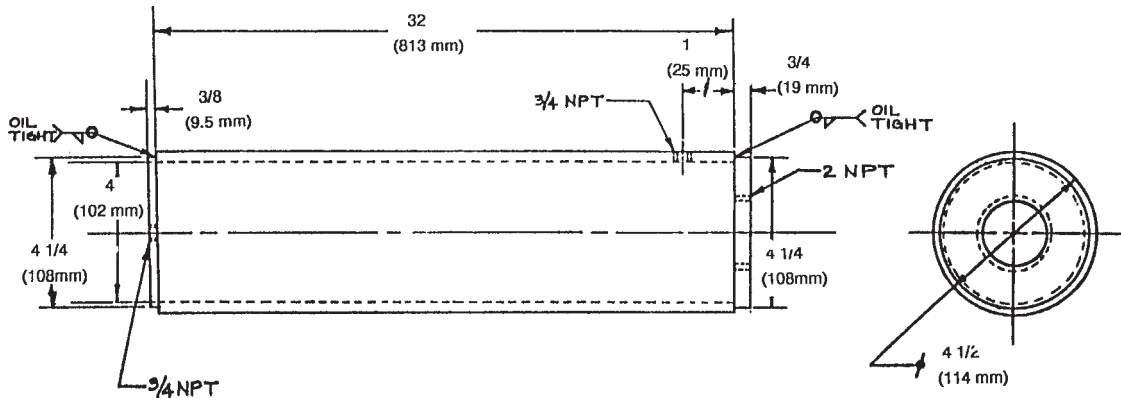

FIG. 3 Schematic of Oil System

thereby placing the driveline at an angle. A layout showing the offset of the transmission relative to the jack shaft is shown in Fig. 2.

6.8 *Instrumentation*—Sensors and displays, either on the test console or in a data logging computer, are to be supplied as follows:

- 6.8.1 Oil sump temperature,
- 6.8.2 Countershaft speed,
- 6.8.3 Tail shaft speed,
- 6.8.4 Air pressure (system),
- 6.8.5 Air pressure (dynamic during shifting), and
- 6.8.6 Coast down time.



NOTE 1—Material 1018 is similar material.
 NOTE 2—All dimensions are in inches, unless otherwise noted.

FIG. 4 Typical Oil Heater Chamber

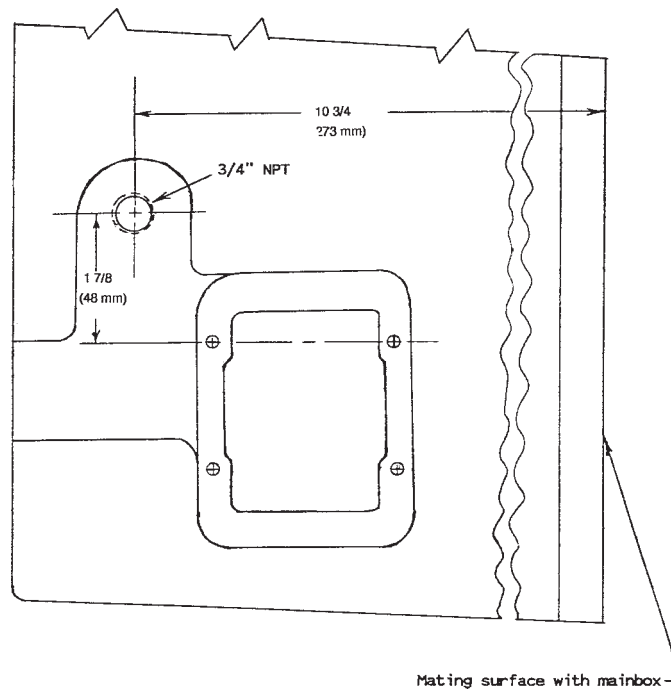

NOTE—Figure is not drawn to scale.
 FIG. 5 Oil Return Hole Location

6.9 *Thermocouple Placement*—Transmission sump temperature is measured in the compound section of the transmission with a thermocouple and conventional display equipment. Drill and tap the compound case to accept the thermocouple at a position located along the centerline of the transmission 8.0 in. (203 mm) forward of the back wall of the main case. Position the tip of the thermocouple to extend 1.5 in. (38 mm) into the sump. As a means of ensuring that the oil is not exposed to excessive heat in the heater, place an additional thermocouple to measure the oil temperature leaving the heater as shown in Fig. 7.

7. Reagents and Materials

7.1 *Oil*—Approximately 12 gal (45.4 L) of test oil is required. The integrity of the test oil is the responsibility of the oil supplier.

7.2 *Cleaning Materials*—A solvent meeting Specification D 235 (Stoddard solvent), or equivalent, D 235—Type II, Class C, is required for cleaning parts.

8. Safety

8.1 The following are suggestions of procedures and equipment that may assist in reducing safety hazards. No attempt has been made to address all possible safety problems. The user of this test method is responsible for establishing appropriate safety and health practices.

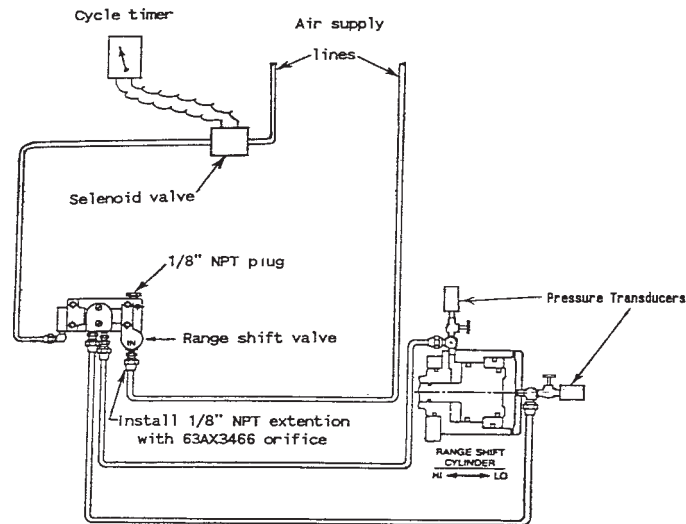

FIG. 6 Air Control and Supply System

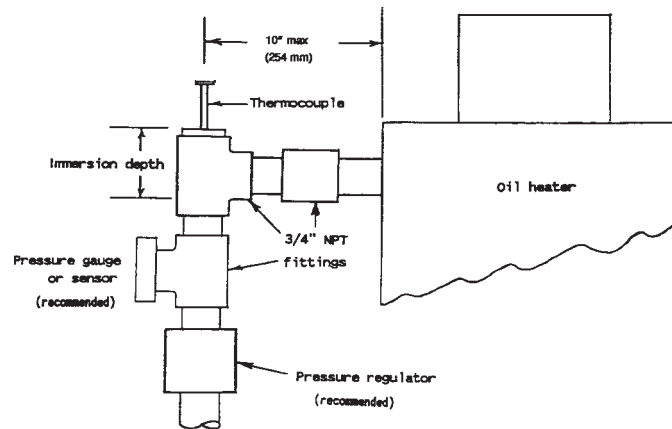

FIG. 7 Location of Oil Out-of-Heater Thermocouple, Pressure Regulator, and Sensor

8.2 The operating of transmission tests can expose personnel and facilities to a number of safety hazards. Only personnel who are thoroughly trained and experienced in transmission testing should undertake the design, installation, and operation of transmission test stands.

8.3 Each laboratory conducting transmission tests should have its test installation inspected and approved by its safety department. Personnel working on the transmissions should be provided with the proper tools, be alert to common sense safety practices, and avoid contact with moving or hot transmission parts, or both. Heavy-duty guards should be installed around the driveline. When the test stand is operating, personnel should be cautioned against working alongside the transmission and drivelines. All oil lines and electrical wiring should be properly routed and grounded, guarded, and kept in good order. Safety masks or glasses should always be worn by personnel working on the transmissions. Loose or flowing clothing, long hair, or other accessories to dress that could become entangled, should not be worn near rotating equipment.

8.4 The external parts of the transmission and the floor area around the transmission should be kept clean and free of oil spills. In addition, the working area should be free of all tripping hazards. In case of injury, no matter how slight, first aid attention should be applied at once and the incident reported. Personnel should be alert for leaking oil, which represents a fire hazard. Containers of oil cannot be permitted to accumulate in the test area.

8.5 A remote station for shutting off the motor, pump, and heater is recommended. Fixed fire-protection equipment should be provided.

8.6 Normal precautions should be taken when using flammable solvents for cleaning purposes. Make sure adequate ventilation is provided and fire-fighting equipment is immediately accessible.

8.7 It is recommended that safeties be provided to shut down the drive motor and oil heater when the following conditions occur:

- 8.7.1 Oil temperature in transmission sump becomes excessive,
- 8.7.2 Oil temperature leaving the oil-heating chamber becomes excessive,

- 8.7.3 Oil-circulating system loses pressure,
- 8.7.4 Motor over-speeds or under-speeds, and
- 8.7.5 The fire-protection system is activated.
- 8.8 See Fig. 8 for a typical schematic of safety circuits.

9. Preparation of Apparatus

9.1 *Cleaning of Parts:*

- 9.1.1 *Transmission Case*—Thoroughly clean the transmission case with Stoddard a cleaning solvent (see 7.2) to remove any oil, sludge, or varnish deposits remaining from the previous test and then air dry.
- 9.1.2 *Gears, Shafts, Synchronizer*—Remove all sludge, varnish, and deposits. Rinse with Stoddard a cleaning solvent (see 7.2) and air dry.
- 9.1.3 *Heater, Oil-Circulating System*— Flush oil lines with Stoddard a cleaning solvent (see 7.2) to remove any previous test oil and then air dry. Disassemble the heater, clean, and air dry after each test. Check the heater periodically for leaks and replace when necessary.

9.2 *Assembly:*

9.2.1 *General*—Assemble all parts as instructed in the Mack Transmission Service Manual T2130/2180,⁶ except where the service manual applies to parts that are modified for this test method. Use the part numbers identified in Table 3 for the appropriate hardware configuration. Use test oil for lubricating parts during assembly. For all tests (reference and non-reference oil) starting after June 9, 1999, use only hardware listed under Configurations 1 or 2 in Table 3.

9.2.2 *New Parts*—Obtain the following parts from an authorized Mack truck dealer. Install the following new parts for each test:

	Number Required	Mack Part No.
Kit (Parts in this kit are listed in Annex A2)	1	377SH21
Friction Plate	8	N/A ⁷
Range Fork	1	575KB457
Low Range Mainshaft Hab	1	84KC47
		(Configuration 2 only)

9.2.2.1 Inspect the following parts after each test and replace if worn or damaged:

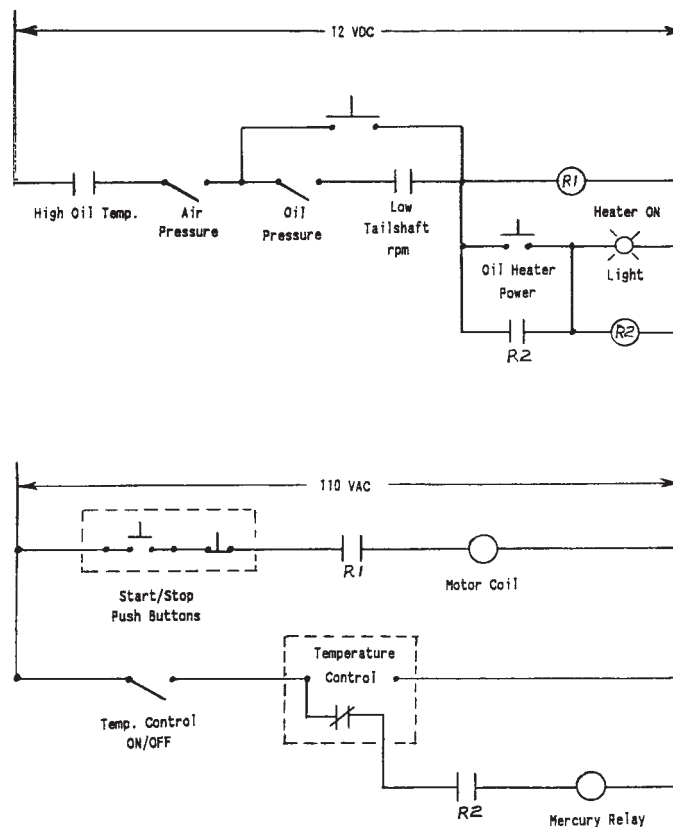

FIG. 8 Typical Schematics of Safety Circuits

TABLE 3 Part Numbers for Approved Configurations

Part description	Test Hardware Configuration	
	Configuration 1	Configuration 2
Synchronizer clutch assembly	320KB450C	320KB459A
Synchronizer pin (3 each)	301KC240B	301KC33
Synchronizer pin (3 each)	301KC241B	301KC34
Synchronizer pin (3 each)	48AX17	301KC35
Synchronizer pre-load spring (3 each)	107KD244	107KD247
High range mainshaft gear	751KB489	751KB4123
Low range mainshaft hub	84KC42	84KC47
Compound mainshaft, rear	601KC429	601KC432
Bearing, compound mainshaft	None required	46AX538
Thrust washers, mainshaft (2 each)	223KD316A	None required
Snap ring (2 each)	97AX151 or 97AX171	97AX151 or 97AX171
Snap ring (2 each)	97AX267	97AX267
Shift rail	591KC3154A	591KC3154A
O-ring, low range shift piston	56AX560	56AX560
Piston, high low range shift	336KC318	336KC318
Cylinder housing, hi-lo shift piston	55KC46A	55KC46A
O-ring, compound shift piston	None required	None required
O-ring, range high low shift piston	56AX588	56AX588
Countershaft gear, front	757KB3322	757KB3322
	757KB4108	757KB4108
Countershaft gear, rear	757KB4106	757KB4106
	757KB440A	
Range shift valve	216KD123	216KD42

	Number Required	Mack Part No.
Thrust Washer	3	223KD249
Thrust Washer	2	223KD316A
Clutch Housing	2	53KC486C
High Range Mainshaft Gear	1	751KB4123
		(Configuration 2 only)

9.2.3 *Inspection of Air Valves*—Inspect the piston of the range shift valve and the fork air cylinder and replace if damaged or visibly worn. Replace the O-rings in these valves when nicked, cut, softened, or hardened. However, replace these O-rings at least every six months. Install a 1/16-in. thick shim between the shaft cylinder and the transmission case for Configuration 2 tests.

9.2.4 *Pre-test Measurements*—Measure the range fork for hardness and thickness at the locations shown in Fig. A54.1. The hardness of the fork pads shall be a minimum of 55 R_c at each of the four locations. Mark the friction disks on the spline tangs with an etching tool at three locations equally spaced. Measure and record the pad thickness at these locations in Fig. A4.3. the Data Dictionary (see Annex A3).

9.2.4.1 This hardness is greater than the manufacturing minimum. Some parts meeting the manufacturing specification may be rejected for this test method.

9.2.5 *Countershaft Bearing Preload*—Measure the pre-load on each of the three countershafts prior to each test as follows:

9.2.5.1 Assemble the transmission as specified in the Mack Transmission Service Manual up to and including installing the yoke on the output shaft. Rotate the transmission so that the shafts are vertical.

9.2.5.2 Remove the bearing cap from the rear cover for the first countershaft to be checked. Measure the thickness of a 0.010-in. (0.254-mm) nominal shim, and record. Add the shim to the shim pack of the shaft, and reinstall the bearing cap. Torque the bolts to 40 to 50 lb-ft (54 to 68 N·m).

9.2.5.3 Mount a dial indicator in the main transmission case, and adjust the indicator probe to measure the axial end play of the countershaft.

9.2.5.4 Using a pry bar, move the countershaft up to the end of travel. Release the lifting force, and record the total travel of the shaft. Repeat this measurement at least three times to ensure that the values are repeatable.

9.2.5.5 Mack specifications call for a preload of from 0.002 to 0.006 in. (0.051 to 0.152 mm). To accomplish this, adjust the shim pack thickness by removing shims equal to the measured end play plus 0.002 to 0.006 in. additional.

9.2.5.6 Repeat this procedure for the other two countershafts. Record the measurements on the form in Fig. A54.3 or an equivalent.

9.2.6 *Transmission Torque Measurement*—Rotate the transmission so that it is in the horizontal position. With the transmission in low range and dry, measure the break and turn torques by turning the output shaft clamp plate capscrew, with a torque wrench, in the normal direction of rotation. Make the measurements three times and report the average of both the break and turn values (see Fig. A54.3). Continue with the assembly of the test apparatus.

⁷ Friction Plates are Wellman Item No. TESTWMP5460.

9.2.7 *Transmission Coast Down Measurement*—With the drive shaft installed but before attaching the top cover, measure the time for the countershafts to coast down from 1500 to 500 r/min, as follows:

9.2.7.1 Shift the transmission into low range. Using a spray bottle charged with the next test oil, spray approximately ½ oz (15 mL) lubricant on each of the main shaft, tail shaft, and six countershaft bearings.

9.2.7.2 Start the drive motor and bring up to speed (countershaft at 1750 r/min). Turn off the motor and allow the transmission to coast down to at least 500 r/min. Electronically measure the time required for the countershafts speeds to decrease from 1500 to 500 r/min using a meter capable of measuring to 0.01 s. See Table 1 for a recommendation. Repeat the coast downs until five readings have been obtained. Calculate the average of these five readings, and record the readings and their average in the appropriate spaces in Fig. A54.3.

10. Calibration

10.1 *Transmission and Test Stand Calibration*—Calibrate transmission and test stands by running tests on reference oils. The purposes are to:

- 10.1.1 Verify standardized transmission operation,
- 10.1.2 Document a test stand severity level, and
- 10.1.3 Determine the passing limit for a given transmission and test stand.

10.2 *Reference Oils*—Two reference oils have been used in the development of this test method, a high-quality (passing) and a poor-quality (failing) oil. Obtain the reference oils from the ASTM TMC.

10.3 *Reference Oil Test Frequency*—Each calibration sequence, conduct a passing reference oil test on each test stand after ten non-reference oil tests or six months, whichever occurs first. Every other calibration sequence, conduct both a passing and a failing reference oil test on each stand sequentially.

10.4 *Instrumentation Calibration*—Calibrate the following instrumentation immediately prior to each set of reference tests. Unless otherwise specified in this test method, follow the instructions provided by the manufacturers of the instruments regarding the method of calibration. In calibrating each instrument, use certified reference standards, having known values covering the range of measurements to be encountered in using this test method, and having tolerances less than those of the measurement tolerances specified in this test method. It is recommended that the calibration records be retained for a minimum of 24 months.

- 10.4.1 Tailshaft and counter shaft speed measurement systems,
- 10.4.2 Temperature sensors and measurement system,
- 10.4.3 Pressure sensors and measurement system, and
- 10.4.4 Shift time measurement system.

10.5 *Shift Time Calibration*—The shift timing system can be calibrated by using an oscillograph, or other equally precise methods, to record the air application event and the counter shaft speeds.

11. Operating Procedure

11.1 *System Flush and Charge:*

11.1.1 Connect all hoses so that the pump, oil heater, and transmission are connected for testing. Charge the system with 5 gal (19 L) of test oil. Turn on the pump to circulate oil through the entire system.

11.1.1.1 If the test oil is a non-reference oil, first ensure that acceptable results on the passing and failing reference oils have been obtained, and then conduct the non-reference oil test on the same hardware configuration used for the reference oil tests.

11.1.1.2 With the oil heater turned off, circulate the oil through the system for a minimum of 10 min.

11.1.1.3 Drain the flush oil by removing the drain plug on the transmission and opening the drain valve on the heater. Allow the system to drain for 10 min.

11.1.4 Replace the drain plug and charge the system with 5.25 gal (19.9 L) of test oil. Complete the assembly of the test apparatus.

11.2 *Test Operation:*

11.2.1 Set the air pressure to 90 psi (621 kPa). Start the drive motor and accelerate the tail shaft to 750 r/min with the transmission operating in low range. Turn on the oil heater.

11.2.2 Continue to operate the transmission in low operating range, not shifting, until the oil temperature is in the operating range, 250 ± 5°F (121 ± 2.7°C).

11.2.3 When the operating temperature is reached, turn on the automatic shifting cyclers, set the cycle timer to zero, and operate under the following conditions:

Tailshaft Speed	750 ± 10 r/min
Cycle Rate	6 ± 0.3-s high range 6 ± 0.3-s low range
Air Pressure	90 ± 2 psi (621 ± 14 kPa)
Temperature	250 ± 5°F (121 ± 2.7°C)

11.2.4 Use the data log sheet shown in Fig. A54.4, or its equivalent, for recording all required operating conditions at least once each hour during the test.

11.2.5 Using an oscillograph and suitable pressure transducers located as shown on Fig. 6 (see Table 1 for recommended equipment), record the shift activating air pressures input shaft and countershafts speeds during at least one shift each from high

to low range and low to high range, during the following periods as applicable: 30 ± 20 , $25\ 000 \pm 300$, $50\ 000 \pm 300$, $60\ 000 \pm 300$ cycles, and a final recording 5000 ± 300 cycles less than the average cycles to failure of the most recent five passing reference tests.

11.2.6 Examine these recordings to ensure that the range shift valve and cylinder are operating properly.

11.3 *Shut-Down Procedure:*

11.3.1 Terminate the test when the transmission experiences two unsynchronized shifts. An unsynchronized shift results in a clashing of the clutch teeth producing a loud noise (exceeding 114 dB). Alternatively, the test can be terminated after the passing limit established by the applicable specification has been achieved without a failure.

11.3.2 Record the final operating conditions, and turn off the shift cycler, oil heater, and drive motor.

11.3.3 Drain and save 1 qt (946 mL) of the test oil. Drain the remainder of the oil from the transmission and heater.

11.4 *Transmission Disassembly*—Disassemble the transmission as specified in the Mack Service Manual and inspect for signs of unusual wear or parts failure. Measure the clutch plates and shifter fork (as described in 9.2.4), and record the measured wear and visual condition of mating surfaces, using the forms shown in Figs. A54.1 and A54.2, or their equivalent.

12. Determination of Test Results

12.1 *Failure Criteria*—The number of shifting cycles to failure of synchronization is the criteria for determining the performance of the lubricant. To ensure that the lack of synchronization is not a single non-repeatable occurrence, terminate the test after two non-synchronized shifts have occurred. The passing limits are established by the specification(s) requiring this test.

12.2 *Shifter Fork Wear*—Measure shifter fork wear and report at the end of test (see Fig. A5.1 and Fig. A5.3). A4.2).

12.3 *Test Validity Determination*—Calculate the validity of the test as described in Annex A1. The test is determined to be operationally valid if the percent deviation of critical operating parameters, the downtime during the test, and the average total cycle time are within the limits specified and defined in Annex A1.

13. Report

13.1 ~~The forms required~~

13.1 For reference oil tests, the standardized report form set and data dictionary for inclusion in reporting the test results and for summarizing the operational data are presented in required. The final test report will include a complete report form package. See Annex A3 for information on obtaining report forms and data dictionary.

13.2 Plot the shift time (see Fig. A3.6), time, scaling the Y-axis from 0 to 6 s on Form 5 (see Annex A3). Plot at least one data point per test hour along the X-axis.

13.23 When reporting reference oil test results to the TMC, transmit by facsimile Figs. A3.1-A3.5 Forms 0 through 5 and any other supporting information to the ASTM TMC within five days of test completion. Mail a copy of the final test report within 30 days of test completion to the ASTM Test Monitoring Center, 6555 Penn Avenue, Pittsburgh, PA 15206-4489. Electronic transfer of test results is also permitted for approved laboratories (see 13.34).

13.34 *Electronic Transmission of Test Results*—Electronic transfer of the test report can also be done utilizing the ASTM Data Communications Committee Test Report Transmission Model (see Section 2 - Flat File Transmission Format) available from the ASTM TMC.

14. Precision and Bias

14.1 Test precision is established on the basis of the most recent five passing reference oil test results in each of four stands. The precision may differ for different test stands. The research report provides the original data used in calculating the test precision.⁸

14.2 As an example of typical precision, Table 4 summarizes the reference oil precision of four test stands, as of April 1993, based upon the last five passing reference oil tests and the last two failing reference oil tests. Current precision data can be obtained by contacting the ASTM TMC.

14.3 The precision of this procedure within one laboratory, using a single batch of clutch plates and two samples of the passing reference oil in the determination of cycles to failure of synchronization, is estimated to be $\pm 19\%$ of the average of the last five passing reference tests in each test stand in that laboratory.

14.4 The averages of the last ten passing reference tests run in each laboratory differed by approximately 16 000 cycles. However, since the reference data are from only two laboratories, the concept of reproducibility is not relevant.

14.5 This procedure has no bias since the ability of the fluid to maintain synchronization of gears during shifting is defined only in terms of this test method.

15. Keywords

15.1 cyclic transmission test; forkwear; manual transmission lubricants; shifting synchronization; shift time; thermal stability; total cycle time

⁸ Supporting data have been filed at ASTM International Headquarters and may be obtained by requesting Research Report RR: D02-1339.

TABLE 4 Reference Oil Precision Results (as of April 1993)

Test Stand	Cycles to Fail	Average Cycles to Fail	Standard Deviation, s	Coefficient of Variation, %
Passing Reference Oil (last 5 tests)				
A	62 798	71 301	9 234	13.0
	68 675			
	64 709			
	74 618			
	85 703			
B	62 560	69 349	7 699	11.1
	82 255			
	69 959			
	65 132			
	66 837			
C	77 696	84 518	10 233	12.1
	86 207			
	99 140			
	72 336			
	87 213			
D	68 419	88 682	14 017	15.8
	99 142			
	97 824			
	79 470			
	98 557			
4 stands, combined	78 463	10 556 ^A	13.0	
Failing Reference Oil (last 2 tests)				
A	23 530	23 548		
	23 566			
B	21 880	23 442		
	25 004			
C	33 260	31 249		
	29 239			
D	27 325	30 482		
	33 638			

^A Pooled standard deviation.

ANNEXES

(Mandatory Information)

A1. TEST VALIDITY CALCULATIONS AND LIMITS

A1.1 For a test to be operationally valid it must not exceed the limits on unscheduled downtime, and deviation from operating parameters and average cycle time as follows.

A1.1.1 Downtime Limits:

A1.1.1.1 *During Warmup*— No limit on number of occurrences nor length of time down.

A1.1.1.2 During test (regardless of length of test):

- (1) Occurrences less than 15-min duration—not counted, but reported.
- (2) Occurrences, over 15-min duration—maximum of three.
- (3) Total time down, no occurrence >16 h.

A1.1.2 Deviation from Test Operating Parameters:

A1.1.2.1 The following operating parameters are considered critical to test validity.

- (1) Oil sump temperature,
- (2) Shift air supply pressure, and
- (3) Tailshaft speed.

A1.1.2.2 The percent deviation of these parameters is calculated as follows:

$$\% = \sum \frac{|\text{amount out of specification}|}{\frac{1}{2} \text{ specification range}} \times \frac{\text{hours out of specification}}{\text{test length, h}} \times 100 \quad (\text{A1.1})$$

NOTE A1.1—A reading out of specification using once-per-hour data recording is considered to be out for the full hour, unless otherwise documented.

A1.1.2.3 The deviation percentages for the critical operating parameters must not exceed:

	Limits, %
Oil sump temperature	2.0
Shift air supply pressure	2.0
Tailshaft speed	5.0

A1.1.2.4 As an example, assume:

- (1) Test length—200 h,
- (2) Oil sump temperature—(250 ± 5°F): 259°F for 1 h,
- (3) Oil sump temperature—(250 ± 5°F): 244°F for 6 h,
- (4) Shift air supply press—(90 ± 2 psi): 93 psi for 2 h, and
- (5) Tailshaft speed—(750 ± 10 r/min) No out of specification readings.

A1.1.2.5 *Oil Temperature:*

$$\frac{4}{5} \times \frac{1}{200} \times 100 = 0.40 \% \quad \frac{1}{5} \times \frac{6}{200} = 0.60 \% \tag{A1.2}$$

$$\text{Total Deviation Percentage} = 0.40 \% + 0.60 \% = 1.00 \%$$

A1.1.2.6 *Air Pressure:*

$$\frac{1}{2} \times \frac{2}{200} \times 100 = 0.50 \% \tag{A1.3}$$

A1.1.3 *Average Cycle Time:*

A1.1.3.1 The average total cycle time for a complete test must be within 12 ± 0.6 s for the test to be considered operationally valid.

$$\text{Average Total Cycle Time} = \frac{3600 \times \text{total operating hours of test}}{\text{total cycles of test}} \tag{A1.4}$$

A1.1.3.2 The total cycle time is the time to complete shifts from low range to high range and back to low range—nominally 12 s.

A2. TEST KIT PARTS

A2.1 Table A2.1 presents the list of test kit parts.

**TABLE A2.1 Test Kit Parts
Mack Truck Kit No. 377SH21**

Name	Quantity	Configuration 1 Part Number	Configuration 2 Part Number
Sliding clutch	1	320KB450C	320KB459
Pin	3	301KC240B	301KC33
Pin	3	301KC241B	301KC34
Spacer tube	3	301KC243C	301KC243C
Ball/Pin	6	48AX17	301KC35
Spring	6	107KD244	107KD247
Reaction disk	8	495KB367	495KB367

A3. HTCT TEST REPORT FORMS AND DATA DICTIONARY

A3.1 Figs. A3.1-A3.6 The required report forms and data dictionary are example test reports forms.

A4. DATA DICTIONARY

A4.1 See Figs. A4.1-A4.3 for available on the Data Dictionary ASTM Test Monitoring Center web page at <http://www.astmtmc.cmu.edu/>, or they can be obtained in hardcopy format from the TMC.

Form 0
Form 1
Form 2

Form 2
Form 3
Form 4
Form 5

Test Report Cover
Test Results Summary Page
Test Conditions and Repeating Field Specifications- Measurements Summary
Test Conditions and Measurements Summary
Downtime and Comments Sheet
Shift Graphs
Shift Time Graphs

A54. MANUAL TRANSMISSION CYCLIC DURABILITY TEST PARTS INSPECTION AND WEAR MEASUREMENTS

A54.1 Figs. A54.1-A54.4 are examples of the necessary report forms.

ASTM International takes no position respecting the validity of any patent rights asserted in connection with any item mentioned in this standard. Users of this standard are expressly advised that determination of the validity of any such patent rights, and the risk of infringement of such rights, are entirely their own responsibility.

This standard is subject to revision at any time by the responsible technical committee and must be reviewed every five years and if not revised, either reapproved or withdrawn. Your comments are invited either for revision of this standard or for additional standards and should be addressed to ASTM International Headquarters. Your comments will receive careful consideration at a meeting of the responsible technical committee, which you may attend. If you feel that your comments have not received a fair hearing you should make your views known to the ASTM Committee on Standards, at the address shown below.

This standard is copyrighted by ASTM International, 100 Barr Harbor Drive, PO Box C700, West Conshohocken, PA 19428-2959, United States. Individual reprints (single or multiple copies) of this standard may be obtained by contacting ASTM at the above address or at 610-832-9585 (phone), 610-832-9555 (fax), or service@astm.org (e-mail); or through the ASTM website (www.astm.org).

(Use these forms to document all required measurements. Some of these measurements may also appear on Figures contained in A3.)

Customer Oil Code _____ Test No. _____ EOT Date _____

Friction Disk Wear (in.)									
Position	Before Test				After Test				Average Wear
	1	2	3	Average	1	2	3	Average	
Plate 1									
Plate 2									
Plate 3									
Plate 4									
Plate 5									
Plate 6									
Plate 7									
Plate 8									

Range Fork Pre-test Hardness	
Location	Hardness, R _c
Front Left	
Front Right	
Rear Left	
Rear Right	

Range Fork Visual Inspection	
Fork Number	
Ridging of Pad Surfaces after Test	
Left Pad	
Right Pad	

Note 1—Use one of the following terms to describe pad surface—none, light, medium, or heavy

FIG. A54.1 Typical Form for Recording Friction Disk Wear

Customer Oil Code _____ Test No. _____ EOT Date _____

Cycles at Wear Measurement _____ EOT Cycles _____

Fork Pad Thickness Wear Measurements (in.)								
	Left ¹				Right ¹			
	Top	Center	Bottom	Average	Top	Center	Bottom	Average
Pre-test								
Post-test								
Left Fork Pad Wear					Right Fork Pad Wear			

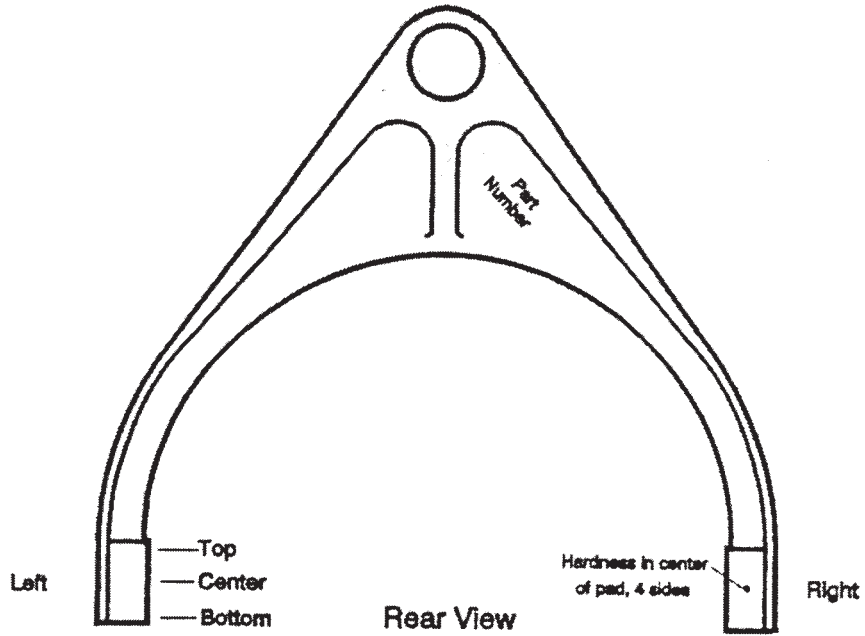

NOTE 1—Side of fork with forged angle and part number is the rear side. View the fork from this side to identify the pads as left and right.

NOTE 2—Post-test wear measurement may be made at EOT or at passing cycles. See “Cycles at Wear Measurement” for the point at which the post-test wear measurement was taken.

FIG. A54.2 Typical Form for Recording Fork Pad Thickness Wear Measurements

Customer Oil Code _____ Test No. _____ EOT Date _____

Preload Measurements (in.)			
	Countershaft Number		
	1A	2A	3A
Preload Measurement			

Pre-test Transmission Break and Turn Torque		
	Break	Turn
Torque, lbf-ft (low range)		

Pre-test Countershafts Coast Down Time	
Time 1, Coasting from 1500 to 500 r/min, s	
Time 2, Coasting from 1500 to 500 r/min, s	
Time 3, Coasting from 1500 to 500 r/min, s	
Time 4, Coasting from 1500 to 500 r/min, s	
Time 5, Coasting from 1500 to 500 r/min, s	
Average Time, s Coasting from 1500 to 500 r/min	

FIG. A54.3 Typical Form for Recording Preload Measurements

Lab Oil Code _____ Customer Oil Code _____ Test No. _____ Page No. _____

			1	2	3	4	5	6	7	8	9	10
Date		1										
Observer		2										
Time		3										
Hours on Test		4										
Hour Meter	Record	5										
Cycles	Record	6										
Cycle Time (12 s)		7										
Tailshaft, r/min	750 ± 10	8										
Counter haft, r/min	HI	9										
Countershaft, r/min	LO	10										
Trans Oil Sump, ° F	250 ± 5	11										
Oil Heater Out, ° F	Record	12										
Lock-up Time, s		13										
Air Pressure, psig	90 ± 2	14										
Oil Pressure, psig	20 ± 2	15										
			11	12	13	14	15	16	17	18	19	20
Date		1										
Observer		2										
Time		3										
Hours on Test		4										
Hour Meter	Record	5										
Cycles	Record	6										
Cycle Time (12 s)		7										
Tailshaft, r/min	750 ± 10	8										
Counter haft, r/min	HI	9										
Countershaft, r/min	LO	10										
Trans Oil Sump, ° F	250 ± 5	11										
Oil Heater Out, ° F	Record	12										
Lock-up Time, s		13										
Air Pressure, psig	90 ± 2	14										
Oil Pressure, psig	20 ± 2	15										

NOTE—Log all shutdowns and repairs on the back of the log sheet.

FIG. A54.4 Data Log Sheet