



Standard Test Method for Evaluation of the Thermal and Oxidative Stability of Lubricating Oils Used for Manual Transmissions and Final Drive Axles¹

This standard is issued under the fixed designation D 5704; the number immediately following the designation indicates the year of original adoption or, in the case of revision, the year of last revision. A number in parentheses indicates the year of last reapproval. A superscript epsilon (ϵ) indicates an editorial change since the last revision or reapproval.

1. Scope

1.1 This test method is commonly referred to as the L-60-1 test.² It covers the oil-thickening, insolubles-formation, and deposit-formation characteristics of automotive manual transmission and final drive axle lubricating oils when subjected to high-temperature oxidizing conditions.

1.2 The values stated in inch-pound units are to be regarded as the standard except for the catalyst weight loss and oil weight measurements, for which the unit is gram; the oil volume, for which the unit is millilitre; the alternator output, for which the unit is watt; and the air flow, for which the unit is milligram per minute. The other SI values, which are in parentheses, are for information only.

1.3 *This standard does not purport to address all of the safety concerns, if any, associated with its use. It is the responsibility of the user of this standard to establish appropriate safety and health practices and determine the applicability of regulatory limitations prior to use.* Specific warning information is given in Sections 7 and 8 and Annex A3.

2. Referenced Documents

2.1 ASTM Standards:³

- B 224 Classification of Coppers
- D 235 Specification for Mineral Spirits (Petroleum Spirits) (Hydrocarbon Dry Cleaning Solvent)
- D 445 Test Method for Kinematic Viscosity of Transparent and Opaque Liquids (the Calculation of Dynamic Viscosity)

¹ This test method is under the jurisdiction of ASTM Committee D02 on Petroleum Products and Lubricants and is the direct responsibility of Subcommittee D02.B0 on Automotive Lubricants.

Current edition approved Nov. 1, 2003. Published December 2003. Originally approved in 1995. Last previous edition approved in 2003 as D 5704-03.

² Until the next revision of this test method, the ASTM Test Monitoring Center (TMC) will update changes in this test method by means of Information Letters. Information Letters may be obtained from the ASTM Test Monitoring Center, 6555 Penn Ave., Pittsburgh, PA 15206-4489. Attention: Administrator. This edition incorporates revisions in all Information Letters through 03-2. The TMC is also the source of reference oils.

³ For referenced ASTM standards, visit the ASTM website, www.astm.org, or contact ASTM Customer Service at service@astm.org. For *Annual Book of ASTM Standards* volume information, refer to the standard's Document Summary page on the ASTM website.

D 664 Test Method for Acid Number of Petroleum Products by Potentiometric Titration

D 893 Test Method for Insolubles in Used Lubricating Oils

E 527 Practice for Numbering Metals and Alloys (UNS)

2.2 ANSI Standard:

ANSI/ISA-S7.3 Quality Standard for Instrument Air⁴

2.3 Military Specification:

MIL-L-2105D Lubricating Oil, Gear, Multipurpose⁵

2.4 ASTM Adjuncts:⁶

Engineering Drawings

3. Terminology

3.1 Definitions:

3.1.1 *carbon, n—in manual transmissions and final drive axles*, a hard, dry, generally black or gray deposit that can be removed by solvents but not by wiping with a cloth.

3.1.2 *lubricant, n—in manual transmission and final drive axles*, lubricating oil.

3.1.3 *sludge, n—in manual transmissions and final drive axles*, a deposit principally composed of the lubricating oil and oxidation products that do not drain from parts but can be removed by wiping with a cloth.

3.1.4 *thermal and oxidative stability, n—in lubricating oils used for manual transmissions and final drive axles*, a lack of deterioration of the lubricating oil under high-temperature conditions that is observed as viscosity increase of the lubricating oil, insolubles formation in the lubricating oil, or deposit formation on the parts, or a combination thereof.

3.1.5 *varnish, n—in manual transmissions and final drive axles*, a hard, dry, generally lustrous deposit that can be removed by solvents but not by wiping with a cloth.

4. Summary of Test Method

4.1 A sample of the lubricant to be tested is placed in a heated gear case containing two spur gears, a test bearing, and

⁴ Joint standard of ANSI/ISA. Available from Instrument Society of America, 67 Alexander Drive, P.O. Box 12277, Research Triangle Park, NC 27709.

⁵ Available from Standardization Documents Order Desk, DODSSP, Bldg. 4, Section D, 700 Robbins Ave., Philadelphia, PA 19111-5098.

⁶ Detailed drawings necessary for rig construction. Available from ASTM International Headquarters. Order Adjunct No. ADJD5704.

a copper catalyst. The lubricant is heated to a specified temperature and the gears are operated for 50 h at predetermined load and speed conditions. Air is bubbled through the lubricant at a specified rate and the bulk oil temperature of the lubricant is controlled throughout the test. Parameters used for evaluating oil degradation after testing are viscosity increase, insolubles in the used oil, and gear cleanliness.

5. Significance and Use

5.1 This test method measures the tendency of automotive manual transmission and final drive lubricants to deteriorate under high-temperature conditions, resulting in thick oil, sludge, carbon and varnish deposits, and the formation of corrosive products. This deterioration can lead to serious equipment performance problems, including, in particular, seal failures due to deposit formation at the shaft-seal interface. This test method is used to screen lubricants for problematic additives and base oils with regard to these tendencies.

5.2 This test method is used or referred to in the following documents:

5.2.1 American Petroleum Institute (API) Publication 1560-Lubricant Service Designations for Automotive Manual Transmissions, Manual Transaxles, and Axles,⁷

5.2.2 STP-512A-Laboratory Performance Tests for Automotive Gear Lubricants Intended for API GL-5 Service,⁸

5.2.3 SAE J308-Information Report on Axle and Manual Transmission Lubricants,⁹ and

5.2.4 U.S. Military Specification MIL-L-2105D.

6. Apparatus

6.1 A description of essential apparatus features is given as follows, including mandatory equipment type and performance specification where established. See Annex A1 and Annex A2 for schematics and additional information of a general nature. Those wishing to build this test apparatus shall base construction on full engineering drawings (see 6.2). A list of suppliers is available from ASTM Headquarters.⁶

6.1.1 *Gear Case Assembly*, used in conjunction with a new test bearing, new lip seals, new O-rings, a pair of new test gears, copper catalyst, and the lubricant to be tested. The gear case assembly has been redesigned to incorporate improvements over designs in use prior to this test method. The gear case and associated parts shall be constructed in accordance with the engineering drawings. The gear case and associated parts shall comply in dimension, material, surface finish where prescribed, and overall design. O-rings and lip seals have been incorporated into this design and are mandatory replacements for the original cork gaskets and shaft slingers used in earlier designs.

6.1.2 *Insulated Oven*, surrounds the gear case assembly and provides insulation sufficient to allow the lubricant temperature to be elevated to and maintained at test temperature conditions.

This oven also houses the heaters and heater blower. The oven dimensions, heater, blower, and oven temperature sensor locations are specified in the engineering drawings (see Annex A1 for approximate locations).

6.1.3 *Heater Elements*—Since this test method is extremely sensitive to temperature, the following specified heater elements (two total) are mandatory:

6.1.3.1 *Primary Heater Element*, one only allowed.^{10,11}

6.1.3.2 *Alternator Load Heater*, one only allowed.^{11,12}

6.1.4 *Temperature Controller*, proportional-integral-derivative (PID) type; percent output adjustable.

6.1.5 *Thermocouples*—For determination, recording, and control of the test oil temperature, a 1/8-in. (3.2-mm) Type J open-tip thermocouple is specified. Thermocouples for other data measurements may be used as suitable to the user but in all cases shall be placed behind the baffle plate in the gear box assembly and shall not interfere with normal oil flow patterns during the test.

6.1.6 *Temperature Recorder*, any suitable recording device capable of generating a temperature record using the specified thermocouples and temperature control devices. Temperature traces for tests shall be submitted with the test report.

6.1.7 *Alternator*—The alternator for loading is specified.^{13,14} No substitutions are allowed. Wiring for the alternator shall be modified as shown in the engineering drawings. Modify the alternator load circuit as shown in Annex A7.

6.1.8 *Heater Blower*—The heater blower system shall supply to the insulated oven assembly 37.5 ± 5 ft³/min (1062 ± 142 L/min) of air (at free flow conditions) through the 2 1/8-in. (54-mm) diameter blower opening as shown in the engineering drawings. The heater blower may be a cage type blower wheel powered by an electric motor or powered by way of a toothed belt from the main drive shaft. In all cases, meet the specified air flow while maintaining other test parameters at their specified value.

6.1.8.1 Confirm the heater blower system air flow with a Preso Low Loss Venturi Meter¹⁴ (2-in. model LPL-200NF-38) with carbon steel body, 1/4-in. NPT instrument connections and 2-in. 150 lb raised-face process connections.

6.1.9 *Air Flow Controller*—The air flow controller^{11,15} shall be capable of controlling the air supply at a flow rate of 22.08 ± 2.01 mg/min (see Note 1).

NOTE 1—It has been suggested that 20 to 30 ft of supply line between the air regulator and the mass air flow meter may help to reduce flow

¹⁰ Chromalox No. 118-553661-505; 1500 W. Available from Anderson Bolos, Inc., 24050 Commerce Park Rd., Cleveland, OH 44122-5838.

¹¹ The sole source of supply of the apparatus known to the committee at this time is noted in the adjoining footnote. If you are aware of alternative suppliers, please provide this information to ASTM Headquarters. Your comments will be given careful consideration at a meeting of the responsible technical committee,¹ which you may attend.

¹² Ogden FD 1Z0895; 150 W. Available from Ogden, 719 W. Algonquin Rd., Arlington Hts., OH.

¹³ Delco-Remy GM Part No. 1105360, Model No. 10-SI Series Type 100, 63 A; 12 V negative ground. Available from S. E. Chevrolet Co., 2810 Bishop Rd; Willoughby Hills, OH 44092 or any other GM dealer.

¹⁴ The sole source of supply of the apparatus known to the committee at this time is SW Controls Inc., 2525 East Royalton Road, Broadview Heights, OH 44147.

¹⁵ Air Flow Controller Model 840-L-1. Available from Sierra Instruments, Inc., 5 Harris Court, Bldg. L, Monterey, CA 93940.

⁷ Available from the American Petroleum Institute, 1220 L St. NW, Washington, DC 20005.

⁸ Supporting data have been filed at ASTM International Headquarters and may be obtained by requesting Research Report RR: D02-1353.

⁹ Available from Society of Automotive Engineers, 400 Commonwealth Dr., Warrendale, PA 15096-0001.

meter readout fluctuations.

6.1.10 *Test Gears*, one machine tool change gear (34 teeth, 3/8-in. (9.5-mm) wide and one machine tool change gear (50 teeth, 3/8-in. (9.5-mm) wide).^{11,16}

6.1.11 *Test Bearing*, ball bearing.^{11,17}

6.1.12 *O-ring Seals*, O-ring for the seal plate and O-ring for the cover plate.^{11,17}

6.1.13 *Lip Seals*, two Chicago Rawhide shaft oil lip seals, part number CR-6383, are required.^{11,17}

6.1.14 *Speedi-sleeve*, two Chicago Rawhide speedi-sleeves, part number CR-99062, are required.^{11,17}

6.1.15 *Joint Radial Seal*, two Chicago Rawhide joint radial (V-ring) seals, part number CR-400164, are required.^{11,17}

6.1.16 *Gear Holder Apparatus*, used to hold the test gears during preparation (Annex A9).

6.2 All new equipment shall be constructed in accordance with the engineering drawings available as an adjunct from ASTM Headquarters⁶ in order to meet calibration requirements. Builders unable to obtain specified parts and wishing to use substitutes shall request approval from ASTM Subcommittee D02.B0.03.

7. Reagents and Materials

7.1 *Air*, compressed, instrument quality, meeting ANSI/ISA-S7.3, that limits dew point, maximum particle size, and maximum oil content of the air at the instrument.

7.2 *Copper Catalyst*, cold-rolled, electrolytic tough pitch copper, conforming to UNS (Unified Numbering System) C11000.¹² The two strips shall be sheared to approximately 1/16 by 1 3/16 in. from 1/16-in. thick stock (approximately 14 by 46 mm from 1.6-mm thick stock).

NOTE 2—For more information on the classification of coppers and the Unified Numbering System (UNS), consult Classification B 224 and Practice E 527, respectively.

7.3 *Organic Cleaning Agent*. (**Warning**—Combustible, vapor harmful (see Annex A3).)^{11,18,19}

7.4 *Silicon Carbide Paper*, 180 grit.

7.5 *Stoddard Solvent*, commercial grade, conforming to the requirements of Specification D 235 (**Warning**—see 7.3).

7.6 *Toluene*, commercial grade (**Warning**—see 7.3). An example of a satisfactory volatile hydrocarbon solvent.

7.7 *Heptane*, commercial grade (**Warning**—see 7.3). An example of a satisfactory volatile hydrocarbon solvent.

8. Preparation of Apparatus

8.1 *Air Box Temperature Limiting Device*—After initial rig installation, preset the oven air temperature limit to 400°F (204°C). This can be achieved by placing the insulated oven cover in position on the rig and installing the air temperature sensor at a penetration depth of 3 in. (75 mm) below the top

inner surface of the cover. Switch on the heaters and circulating fan. Adjust the temperature control device to deactivate the heaters when the air temperature reaches 400°F. This oven temperature limit may later be reduced as outlined in 10.3 to meet rig heat-up requirements.

8.2 *Temperature Recording and Controlling Instrumentation*—Since this test procedure is extremely sensitive to temperature, it is necessary to maintain a periodic check upon the accuracy of all items related to temperature measurement and control. Therefore, immediately after the installation of a new test rig, and before every set of reference tests, the instrumentation used to measure and record the air and oil temperatures shall be calibrated against known standards traceable to NIST.²⁰ For instance, the oil temperature thermocouple and indicating controller shall be calibrated. This can be accomplished by immersing the tip of the probe into an auxiliary temperature-controlled oil bath equipped with a stirrer. The bath temperature shall be set accurately at 325°F (162.8°C) and the test measuring equipment shall be confirmed to be accurate prior to testing.

8.3 *Gear Case*—Clean the gear case, vent tube, vent tube baffle, retainer bushings, seal sleeves, case cover plate, seal plate, nuts, studs, flat washers, baffle plate, spacer bushings, bearing bushings and clamp, keys, shaft ends, shaft nuts, and catalysts (**Warning**—see 7.3). Nylon bristle brushes and long pipe cleaners can be used to aid cleaning. (**Warning**—Since the proper operation of the apparatus depends upon the maintenance of numerous accurately machined surfaces, do not use steel brushes or abrasive cloth materials except as noted in 8.4.) Following the cleaning procedure with an organic cleaning agent, wash parts thoroughly with Stoddard solvent (**Warning**—see 7.3), and finally with a volatile hydrocarbon solvent (**Warning**—see 7.3), to facilitate air drying. Allow parts to air dry.

8.4 *Test Gears*—Thoroughly clean the test gears with Stoddard solvent. Carefully examine the gear teeth for nicks and burrs. Do not use gears with major imperfections. Redress minor gear teeth imperfections with a fine stone or file.

8.4.1 Prepare each gear with one piece of Screen-Kut silicon carbide C-180 paper.²¹ Use one side of the silicon carbide paper to prepare one side of a gear. Use the opposite side of the silicon carbide paper to prepare the opposite side of the gear. Place a piece of silicon carbide paper on a solid surface that has a thickness greater than or equal to 1/2 in. Saturate the entire silicon carbide paper with Stoddard solvent. Sand both sides of the test gears, with the required gear holder apparatus (6.1.16), on the silicon carbide paper using a figure eight motion. Do not apply a downward force to the gear holder while sanding. Sand the gears until the manufacturer's machining marks are removed. Prepare the test gears prior to the catalyst. A third sheet of silicon carbide paper may be used to prepare the catalyst strips. After final examination, wash gears once more with Stoddard solvent and finally with a volatile hydrocarbon

¹⁶ GA-34 and GA-50 gears are available from Boston Gear Works, 14 Hayward St., Quincy, MA 02171.

¹⁷ R-14 10 ball bearing, No. 2-153 (seal plate O-ring), No. 2-264 (cover plate O-ring), CR-6383 seals, CR-400164 seals, and CR-99062 speedi-sleeves are available from Motion Industries, 4620 Hinckley Parkway, Cleveland, OH 44109.

¹⁸ Available from Oakite Products, Inc., 13177 Huron River Dr., Romulus, MI 48174.

¹⁹ Available from Pentone Corp., 74 Hudson Ave., Tenafly, NJ 07670.

²⁰ National Institute of Standards and Technology (formerly National Bureau of Standards), Gaithersburg, MD 20899.

²¹ The sole source of supply of the apparatus known to the committee at this time is McMaster-Carr Supply Company, part number 4677A14.

solvent, to facilitate air drying. Allow gears to air dry. If the gears are not to be used immediately, wrap them in a paper towel and Nox-Rust paper.²² Start the test within 24 h after polishing is completed.

8.4.2 Discard the test gears if not used within 24 h.

8.5 *Test Bearing*—Prior to installation, wash the test bearing first with Stoddard Solvent, and finally with a volatile hydrocarbon solvent, to facilitate drying. Allow the bearing to air dry.

8.6 *Copper Catalyst*:

8.6.1 Notch one strip for purpose of identification. The notch shall be triangular in shape centered on the long side of the strip. Sides of the triangular notch shall be equal and approximately 0.2 in. (approximately 5 mm) in length.

8.6.2 Polish both catalyst strips on all six sides with a 180-grit silicon carbide paper.

8.6.3 Wipe both catalyst strips with absorbent cotton pads moistened with Stoddard solvent, and wash with a volatile hydrocarbon solvent, to facilitate drying. Allow catalyst strips to air dry.

8.6.4 Record the weight of the catalyst with the notched strip to the nearest 0.0001 g prior to installation. Cleaned catalyst strips shall be handled with tweezers or ashless filter paper in order to avoid contamination of the catalyst surface by way of skin contact.

8.7 *Gear Case Assembly*—Assemble the gear case components (see Annex A2 for exploded view).

8.7.1 Inspect all parts prior to assembly of the gear case. Replace any parts that would affect proper rig operation (for example, overly worn parts). Parts replacement is left to the discretion of the rig builder. A modified seal plate, detailed on gear case drawing number C-3963-1277-2⁶ may be used to facilitate removal of the lip seals.

8.7.2 Use new elastomer components (O-rings and lip seals) for each test.

8.7.3 Install the retainer bushings and seal sleeves. Replace the seal sleeves if they are grooved.

8.7.4 Install the lip seals and O-ring seal in the seal plate. The application of gasket sealant^{23,11} to the lip seals to prevent oil leaks is an approved option.

8.7.5 Install the seal plate in the gear case, using the flat washers to protect the seal plate surface from damage. Torque the seal plate retaining studs to approximately 25 lbf-in. (approximately 2.8 N·m).

8.7.6 Install the external retaining rings on the upper and lower shafts.

8.7.7 Install the upper and lower spacer bushings on the upper and lower shafts.

8.7.8 Install the baffle plate and catalyst holder and torque to approximately 25 lbf-in. (approximately 2.8 N·m), using the flat washers to protect the baffle plate and catalyst holder surfaces.

8.7.9 Insert the bearing into the test bearing clamp with the bearing clamp shoulder on the opposite side of the bearing

manufacturer's number. Use the bearing clamp cap screw to bolt the bearing clamp closed and torque to approximately 25 lbf-in. (approximately 2.8 N·m). Install the locking nut to ensure that the bolt does not move during the test.

8.7.10 Insert the test bearing bushing into the test bearing with the bearing bushing shoulder on the same side of the bearing as the manufacturer's number. Install this entire assembly on the lower shaft so that the bearing manufacturer's number faces the front of the gear case. If the bearing assembly has been assembled properly, the bearing clamp arm will be on the opposite side of the gear case as the catalyst holder.

8.7.11 Install the large gear (GA-50) on the lower shaft and the small gear (GA-34) on the upper shaft along with the shaft keys. Install the test gears so that the manufacturer's name faces the front of the case. Install the retaining nuts and torque to approximately 90 lbf-in. (approximately 10 N·m). (**Warning**—The gear retaining nuts are different since the lower shaft is right-hand thread and the upper shaft is left-hand thread.)

8.7.12 Insert the test oil thermocouple so that the tip protrudes perpendicular to the slanted lower right side of the gear case assembly and protrudes 0.50 ± 0.04 in. (13 ± 1 mm) into the gear case.

8.7.13 Insert catalysts in the grooves on the catalyst holder. Catalysts shall be sized for a tight fit in the catalyst holder to avoid movement of the catalysts during the test. Placement of the notched strip toward the rear of the gear case with the notch facing rearward is recommended for ease of catalyst removal after test with minimal disturbance of deposits.

8.7.14 Install the O-ring seal on the gear case cover.

8.7.15 Install the gear case cover and torque the cap screws to approximately 25 lbf-in. (approximately 2.8 N·m).

8.8 *Air Supply Line*—Ensure that the air supply line is free from obstructions and then connect the air supply line to the bottom of the gear case.

8.9 *Insulated Oven Cover*—Ensure that the oven temperature sensor is at a penetration depth of 3.0 ± 0.2 in. (76 ± 5 mm) below the top inner surface of the cover (see 7.5). Install the cover on the rig.

8.10 *Air Flow Controller Calibration*—Prior to the start of a calibration cycle on a stand, calibrate the air flow controller to a traceable standard. Calibrate the traceable standard a minimum of once every year to the sole flow rate specification of 22.08 ± 2.01 mg/min at the outlet and 30 psig (206 kPa) inlet pressure. Connect the calibrated traceable standard, Sierra Top Trak Model 820, to the inlet of the Sierra Side Trak Model 840. Connect the outlet line of the Sierra Side Trak Model 840 to the gear box. Install an air pressure measurement device to monitor and regulate the inlet pressure to 30 psig (206 kPa). Charge the gear box with a commercial 80W-90 grade oil and bring to test conditions [$325 \pm 1^\circ\text{F}$ ($162.8 \pm 0.5^\circ\text{C}$) at 1750 ± 50 r/min]. Remove the Top Trak after completing the calibration.

9. Calibration and Standardization

9.1 Reference oils for stand calibration are available from the TMC.² Laboratories wishing to calibrate test stands using these reference oils shall participate in the referencing and stand calibration program administered for this test by the TMC (see Note 3 and Annex A4).

²² The sole source of supply of the apparatus known to the committee at this time is DaubertVCI, Inc., 1333 Burr Ridge Parkway, Suite 200, Burr Ridge, IL 60527.

²³ Perfect Seal Gasket Maker No. 4, Part No. 1050026. Available from P.O.B. Manufacturing Inc., 1100 Kenwood Road, Cincinnati, OH 45242.

NOTE 3—*TMC Acceptance Criteria*—Reference oil performance and test operations for this test method are currently monitored by the TMC. Statistics for reference test starts are published periodically by the TMC and provide acceptance ranges for the various reference oils. Users of the test method should contact the TMC for the most current values for evaluation of referencing status.

9.2 To ensure that uniform results are being obtained in the test, calibration of test stands shall be completed by testing reference oil samples supplied by the TMC at the time calibration or recalibration is required.

9.2.1 *New Test Stand Calibration*—For a new test stand, reference tests as prescribed by the TMC shall be completed, giving results within the established limits for the reference oils. Inspection of the new test stand for compliance with this test method by the TMC is also required.

9.2.2 *In-Service Stand Calibration*—For a previously referenced test stand, reference tests giving results within the established limits for those oils shall be conducted at the frequency specified by the TMC (currently every ten tests or three months, whichever occurs first). Test oils for this purpose are distributed as blind coded samples by the TMC when request for calibration is received. All test starts and test data using reference oils shall be reported to the TMC. Calibration frequency is subject to change as required. Current calibration information is available from the TMC.

9.3 Every test start on any test stand shall receive a sequential test run number designated before testing begins. All tests, including aborted starts and operationally invalid tests, shall retain their test number.

9.4 *Instrumentation Calibration*—Prior to a reference oil test, calibrate the large gear shaft speed system, alternator output system, blower motor output system, air flow controller system, air box temperature control system, and oil temperature control system against known standards traceable to NIST.

10. Procedure for Conducting the Test

10.1 Pour 120 ± 5 mL of the lubricant to be tested into a clean container. Weigh the container of oil. Charge the gear case with the test lubricant. Reweigh the container and determine the oil charged by subtraction. Record the weight of the test oil charge to the nearest 0.01 g.

10.2 Preset air flow rate to 22.08 ± 2.01 mg/min.

10.3 Record the time, turn on the main drive motor, and adjust the temperature control system to maintain the bulk test lubricant temperature at $325 \pm 1^\circ\text{F}$ ($162.8 \pm 0.6^\circ\text{C}$). The bulk oil test temperature shall be heated from ambient to 324°F (162.2°C) in a minimum of 45 min. This heat-up time shall not exceed 60 min. Tests with heat-up times less than 45 min or greater than 60 min are not representative of an operationally valid test and, therefore, cannot be properly interpreted for non-reference oil evaluation. The end-of-heat-up/test start time shall be the first occurrence of 324°F (162.2°C).

10.3.1 Record all operational data at a minimum of once every 15 min. A reading out of specification using once-every-15 min data recording is considered to be out for the full 15 min unless otherwise documented.

10.4 If the rig heat-up time is less than 45 min, the oven temperature limit should be reduced until the heat-up time is equal to or greater than 45 min but less than 60 min. A possible

cause of heat-up times greater than 60 min is improper fit between the insulated oven and insulated oven cover or other areas of excessive oven thermal leakage, or both. Under no circumstances shall the oven temperature limit be set higher than 400°F (204°C). The rig heat-up time should be checked prior to every set of reference tests to ensure consistent rig performance.

10.5 Adjust the field supply of the alternator for a net output of 128 ± 5 W.

10.6 The large gear shall maintain a speed of 1750 ± 50 r/min throughout the heat-up and test time.

10.7 Run the test at the conditions specified and without interruption for 50.0 ± 0.1 h. Terminate the test if it is interrupted for more than 5 min total during the test period. Record any downtime on Form 4, Annex A5.

10.7.1 Record all operational data at a minimum of once every hour. A reading out of specification using once-every-hour data recording is considered to be out for the full hour unless otherwise documented.

10.8 At the completion of the test, immediately shut down the equipment, remove the air line, and drain the test lubricant into a clean weighed container. The gear case cover plate may be loosened to facilitate draining, but do not remove it. Drain the test stand for 30 ± 5 min. Weigh the container of drain oil, and determine the drain oil weight by subtraction. Calculate the oil loss in weight percent using Eq 1. Tests exceeding 20 % weight oil loss are not representative of an operationally valid test and, therefore, cannot be properly interpreted for non-reference oil evaluation.

$$\text{oil loss in weight \%} = \frac{\text{initial weight} - \text{final weight}}{\text{initial weight}} \times 100 \quad (1)$$

where:

initial weight = initial oil charge weight, and
final weight = drain oil weight.

10.9 At the completion of the oil weight loss calculation, transfer the entire oil drain, including solids, using a flat-bladed stainless steel tool from the weighed container into a single sample bottle for kinematic viscosity, pentane insolubles, toluene insolubles, and total acid number evaluation as outlined in Section 13. The single sample bottle contents shall be homogenous prior to kinematic viscosity, pentane insolubles, toluene insolubles, and total acid number evaluation.

10.10 Remove the gear case cover and test gears within 60 + 5 min of test completion without disturbing the deposits on the various test gears.

11. Procedure for Determination of the Gear Cleanliness Ratings²⁴

11.1 Evaluation of the test gears is performed after removing the catalyst strips, test gears, test bearing, and internal gear case components.

11.2 After gear case disassembly, as specified in 10.10, immediately place test parts side-by-side in a draining position

²⁴ Training for those rating gear sets for cleanliness parameters may be obtained from Coordinating Research Council (CRC), 219 Perimeter Ctr. Pkwy., Atlanta, GA 30346.

(A draining position is a position within 15° of vertical.) at room temperature for a minimum of 1 h before rating. Rate the test parts within 64 h of test completion.

11.3 Gear Sludge Rating:

11.3.1 Wipe an approximately 3/4-in. (20-mm) wide area across the diameter along the key way on each face of both large and small test gears. Rate each gear face for sludge individually.

11.3.2 The total ratable area for sludge on each gear face excludes the wiped area, gear teeth, and spacer bushing contact area.

11.3.3 Subdivide the total ratable area into percentage areas of different sludge depths and ratings using CRC Manual No. 20 (utilizing the sludge scale and sludge gage, which are included in the manual) as a guide. Calculate and record the sludge volume factor for each subdivided area. The total volume factor for a gear face is determined by adding the individual area volume factors for that gear face.

11.3.4 Convert the total volume factor for each gear face to a merit rating using CRC Manual No. 20.²⁴ Report this rating to two decimal places.

11.3.5 The sludge rating is defined as the average of the four merit ratings of the four gear faces.

11.4 Gear Carbon/Varnish Rating:

11.4.1 Determine the carbon/varnish rating using the large gear only, although the small gear may be rated for additional information. Rate the front and back faces of both gears individually. The wiped area on each gear face, excluding the gear teeth and spacer bushing contact area, is the ratable area.

11.4.2 Using the current CRC Manual No. 20 as a guide, subdivide the ratable area on each gear face into percentage areas of different carbon depths and varnish intensities.²⁴ Use the CRC Rust/Varnish/Lacquer Rating Scale for Non-Rubbing Parts in CRC Manual No. 20 to determine varnish rating factors for each subdivision containing varnish deposits.

11.4.3 Rate carbon from 0.00 (heavy carbon) to 0.99 (trace carbon) using an expanded rating scale. Determine carbon rating factors from Table 1 by determining the carbon depth and description for each subdivided area. Calculate the carbon merit rating by multiplying the rating factor by the percentage area. Report this rating to two decimal places.

11.4.4 Determine the carbon/varnish merit rating for a gear face by adding the individual area merit ratings for the wiped area of that face.

11.4.5 The carbon/varnish rating is defined as the average of the front and back face merit ratings for the large gear. The small gear should be rated similarly, but separately, for additional information.

11.5 Use Form 5, Annex A5 for calculating and reporting carbon/varnish and sludge rating measurements.

11.6 For the test rating to be valid, the gears shall be rated by an individual who has participated in a CRC sponsored, high-volume, gear-rater calibration workshop within the previous twelve months.²⁴

12. Procedure for Determination of Catalyst Weight Loss

12.1 Determine the Catalyst Weight Loss:

12.1.1 Carefully remove all the deposits from the notched copper catalyst strip by soaking for 30 min in Oakite 811, Penmul L460, or equivalent.

12.1.2 Wash in Stoddard solvent.

12.1.3 Remove deposit residue from the surface by rubbing lightly with a clean cloth.

12.1.4 Wash in Stoddard solvent.

12.1.5 Wipe with absorbent cotton pads moistened with a volatile hydrocarbon solvent.

12.1.6 Wash in a volatile hydrocarbon solvent. Allow catalyst strip to air dry.

12.1.7 The cleaned catalyst strip shall be handled with tweezers or ashless filter paper in order to avoid inaccurate weight loss information. Record the weight of the cleaned catalyst with the notched strip to the nearest 0.0001 g to determine the copper activity of the test lubricant. The weight loss is reported as a percent loss based upon the original weight of the notched strip.

13. Procedure for Evaluation of Drain Oil

13.1 Determine the following test lubricant parameters (pay particular attention to the sample handling instructions in the relevant standard):

13.1.1 Kinematic viscosity of the untested oil and of the drain oil in centistokes at 212°F (100°C) using Test Method D 445. Do not filter the sample. Run the post-test viscosity determination within 48 h of the end of the test.

13.1.2 Total acid number of the drain oil using Test Method D 664.

13.1.3 *n*-Pentane and toluene insolubles using Test Method D 893, Procedure A without coagulant. Evaluate the pentane/toluene insolubles within 48 h of the end of the test.

14. Calculation

14.1 Calculate the percent viscosity increase by Eq 2, using the initial oil kinematic viscosity and the drain oil kinematic viscosity.

$$\% \text{ viscosity increase} = \frac{\text{final KV} - \text{initial KV}}{\text{initial KV}} \times 100 \quad (2)$$

where:

KV = kinematic viscosity.

14.2 Calculate the catalyst percent weight loss using Eq 3:

$$\text{catalyst loss in weight \%} = \frac{\text{catalyst initial weight} - \text{catalyst final weight}}{\text{catalyst initial weight}} \times 100 \quad (3)$$

where:

catalyst initial weight = initial catalyst weight as determined in 8.6.4, and

catalyst final weight = final catalyst weight as determined in 12.1.7.

TABLE 1 Carbon Depth Rating Guidelines

Visually Estimated Carbon Depth, in.	Visually Estimated Carbon Depth, mm	Carbon Description	Carbon Rating Factor Range
>0.00 up to 0.02	>0.0 up to 0.5	Light	0.99–0.81
>0.02 up to 0.08	>0.5 up to 2.0	Medium	0.80–0.11
>0.08	>2.0	Heavy	0.10–0.00

14.3 Use the following equations to transform reference and non-reference oil results:

Parameter	Transformations
EOT viscosity increase (%)	LN(VI)
EOT pentane insolubles (% volume)	LN(Pentane)
EOT toluene insolubles (% volume)	LN(Toluene)
Average carbon/varnish (merits)	LN(CV/(10-CV))
Average sludge (merits)	-LN(10-Sludge)

14.4 Correct non-reference oil results for industry severity using the equations detailed in Annex A6. Correct non-reference oil results for stand severity using the equations detailed in Annex A8.

14.5 Calculate percent out for each parameter in Table 2 using the following equation and record results in Form 6, Annex A5.

$$\text{percent out} = \sum_{i=1}^n \left(\frac{M_i}{0.5R} \times \frac{T_i}{D} \right) \times 100 \quad (4)$$

where:

M_i = magnitude of test - parameter out from specification limit at occurrence i ,

R = test parameter specification range,

T_i = length of time the test parameter was outside of specification range at occurrence i , (T_i is assumed to be no less than the recorded data-acquisition frequency unless supplemental readings are documented.), and

D = test or test phase duration in same units as T_i .

14.5.1 Invalidate any test that exceeds the percent out limits in Table 2 for either warm up or on test conditions.

15. Report

15.1 For reference oil tests, the standardized report form set and data dictionary for reporting the test results and for summarizing the operational data are required. The final test report will include a complete report form package. See Annex A5 for information on obtaining report forms and the data dictionary.

15.2 Attach the temperature recording trace, including heat-up time.

15.3 For non-reference tests with a value of zero for viscosity increase, pentane insolubles, or toluene insolubles, report a value of zero as the test result and report *NA* for the transformed results. For tests with viscosity results that are too viscous to measure, report a value of *NA* as the test result and the transformed result. For test results where viscosity is too viscous to measure or have a value of zero for viscosity

increase, pentane insolubles, or toluene insolubles, do not apply any severity adjustment.

15.4 When reporting reference oil test results to the TMC, transmit by facsimile, the complete report form package (Annex A5) and any other supporting information to the ASTM TMC within five days of test completion. A copy of the final test report shall be mailed within 30 days of test completion to the ASTM Test Monitoring Center, 6555 Penn Avenue, Pittsburgh, PA 15206-4489. Electronic transfer of test results (see 15.6) to the ASTM TMC is also permitted for approved laboratories.

15.5 *Deviations from Test Operational Limits*—Report all deviations from specified test operational limits of Form 4 of Annex A5 under Other Comments.

15.6 *Electronic Transmission of Test Results*—Electronic transfer of reference and non-reference oil test report data can be done utilizing the ASTM Data Communications Committee Test Report Transmission Model (see Section 2—Flat File Transmission Format) available from the ASTM TMC.

15.7 Attach the operational recording traces for all parameters in Table 2 as part of the test report.

16. Precision and Bias

16.1 Test precision is established on the basis of reference oil test results (for operationally valid tests) monitored by the ASTM TMC. The data are reviewed semi-annually by the L-60-1 Surveillance Panel. Contact the ASTM TMC for current industry data. Table 3 summarizes reference oil precision of the test as of June 30, 1997.

16.1.1 *Intermediate Precision (i.p.) (formerly called Repeatability)*—The difference between two results obtained by the same operator or laboratory with the same gear batch, on the same oil, using the same test method, would, in the long run, in the normal and correct conduct of the test method, exceed the values shown in Table 3 in only one case in twenty.

16.1.2 *Reproducibility (R)*—The difference between two single and independent results obtained by different operators working in different laboratories on the same oil, would, in the long run, in the normal and correct conduct of the test method, exceed the values shown in Table 3 in only one case in twenty.

16.2 Bias is determined by applying an accepted statistical technique to reference oil results, and when a significant bias is

TABLE 2 Test Validity Parameters

	Parameter			
	Oil Temperature	Air Flow	Alternator Load	Large Gear Speed
Specification Range	325°F 2°F	22.08 mg/min 4.02 mg/min	128 W 10 W	1750 r/min 100 r/min
% Out of Specification (warm up)	N/A	10 %	10 %	5 %
% Out of Specification (test)	5 %	5 %	5 %	2 %

TABLE 3 Reference Oil Test Precision Data—Transformed Units

NOTE—These statistics are based on results obtained on Test Monitoring Center Reference Oils 131–3, 131–4, 143, and 148.

where:

$S_{i.p.}$ = intermediate precision standard deviation,

$i.p.$ = intermediate precision,

S_R = reproducibility standard deviation, and

R = reproducibility.

Variable	$S_{i.p.}$	$i.p.$	S_R	R
Viscosity increase, 1n (% Increase)	0.148	0.414	0.150	0.420
Pentane insolubles, 1n (% of wt)	0.396	1.109	0.419	1.173
Toluene insolubles, 1n (% wt)	0.512	1.434	0.516	1.445
Average sludge, -ln (10-merit)	0.255	0.714	0.270	0.756
Average carbon varnish, ln (merit/ (10-merit))	0.360	1.008	0.384	1.075

determined, a severity adjustment is permitted for non-reference oil test results (see 14.4, Annex A6, and Annex A8).

17. Keywords

17.1 carbon and varnish deposits; final drive axle; gear cleanliness; gears; insoluble; L-60; lubricants; manual transmission; oil thickening; seal failure; sludge; thermal oxidation

ANNEXES

(Mandatory Information)

A1. DIAGRAM OF TEST APPARATUS

A1.1 Fig. A1.1 presents a diagram of the test apparatus.

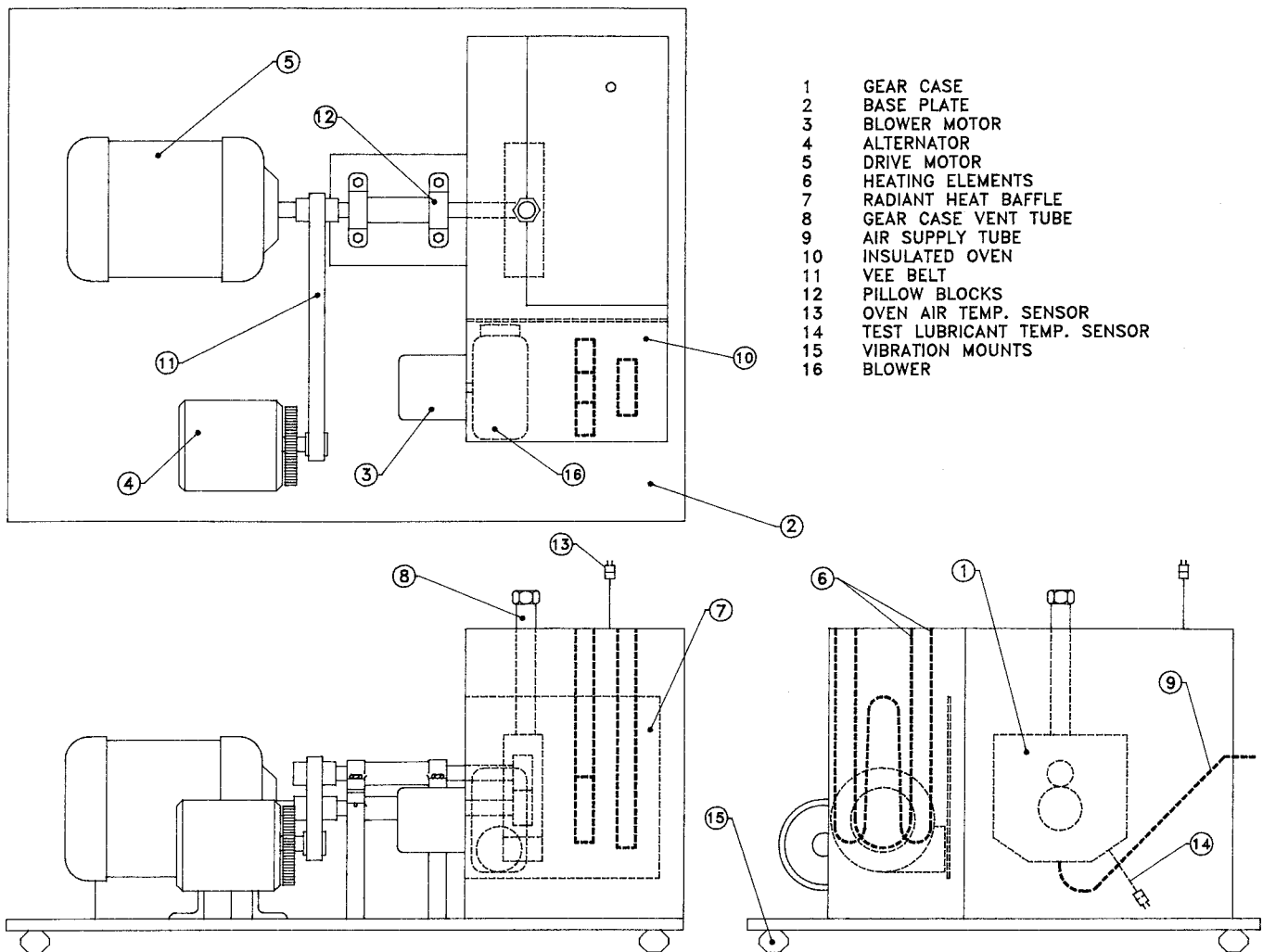

FIG. A1.1 Diagram of Test Apparatus

A2. EXPLODED VIEW OF GEAR CASE ASSEMBLY

A2.1 Gear Case Assembly Parts List (see Fig. A2.1):

- | | | |
|--|--|---|
| (1) Lower Shaft (Right-Hand Thread) | (14) Stainless Steel Stud | (27) Bearing Bushing |
| (2) Upper Shaft (Left-Hand Thread) | (15) Stainless Steel External Retainer | (28) Shaft Key, 1/8 in. by 3/8 in. |
| (3) Gear Case Support | (16) Baffle Plate | (29) GA-50 Test Gear |
| (4) Retainer Bushing | (17) Catalyst Holder | (30) GA-34 Test Gear |
| (5) Seal Sleeve, CR-99026 | (18) Stainless Steel Flat Washer, 5/16 in. | (31) Gear Retaining Nut (Right-Hand Thread) |
| (6) Spacer Washer | (19) Stainless Steel Hex Nut, 5/16 in.—18 | (32) Gear Retaining Nut (Left-Hand Thread) |
| (7) Gear Case | (20) Catalyst | (33) O-ring No. 2-264 |
| (8) Cap Screw, 5/16 in.—24 by 3/4 in. | (21) Upper Spacer Bushing | (34) Gear Case Cover Plate |
| (9) Vent Tube | (22) Lower Spacer Bushing | (35) Lock Washer, #10 |
| (10) O-ring No. 2-153 | (23) Bearing Clamp | (36) Cap Screw, 10-32 by 3/4 in. |
| (11) Lip Seal, CR-6383 | (24) Stainless Steel Cap Screw, 10-32 by 3/4 in. | (37) Vent Tube Baffle |
| (12) Seal Plate | (25) Stainless Steel Hex Nut, 10-32 | |
| (13) Stainless Steel Flat Washer, 5/16 in. | (26) R-14 Test Bearing | |

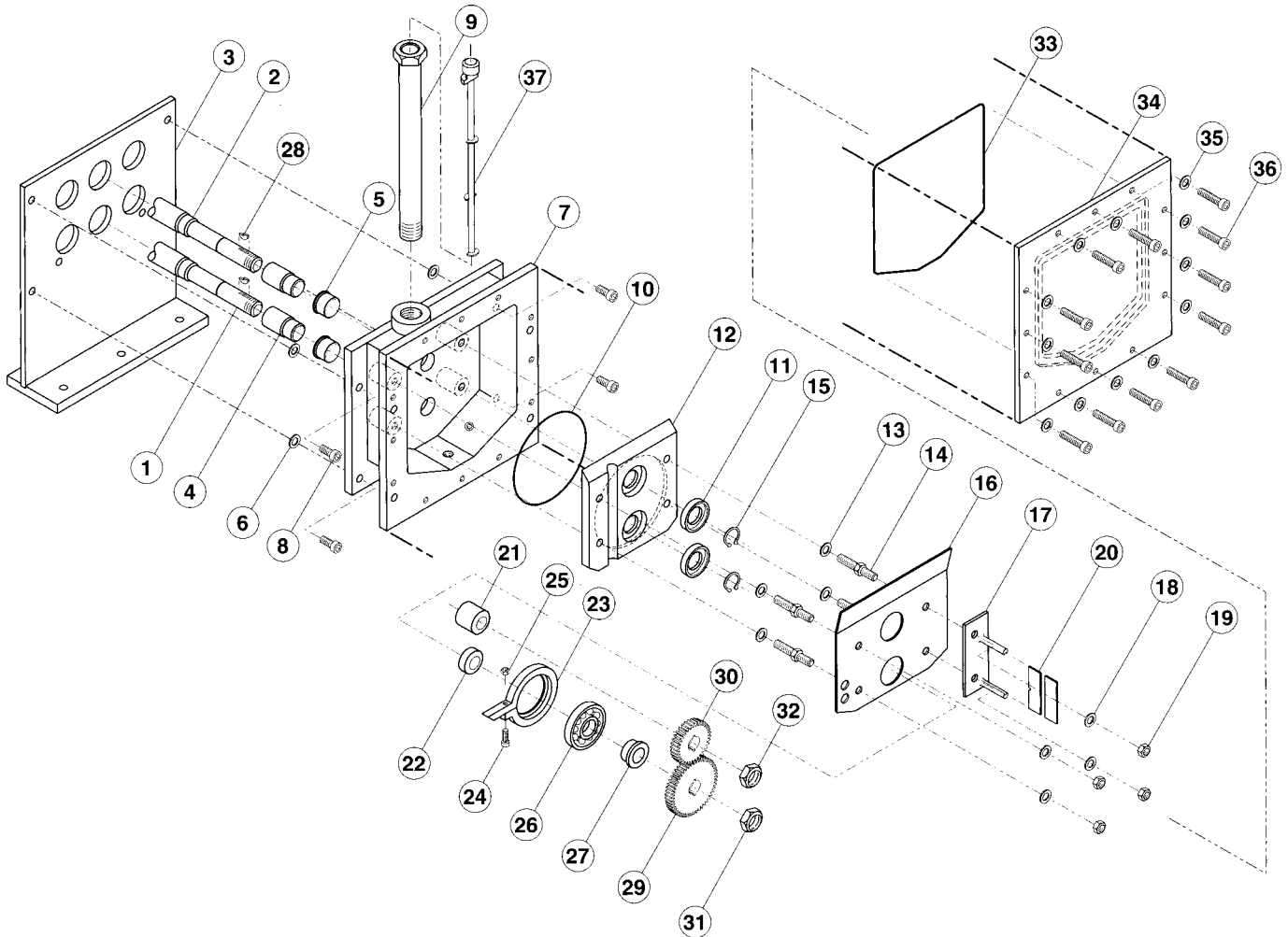

FIG. A2.1 Exploded View of Gear Case Assembly

A3. WARNING STATEMENTS

A3.1 *Oakite 811, Penmul L460* (volatile hydrocarbon solvent, examples are toluene and heptane), *Stoddard Solvent*:

- A3.1.1 Vapors may cause flash fire.
- A3.1.2 Keep away from heat, sparks, and open flame.
- A3.1.3 Keep container closed.
- A3.1.4 Use with adequate ventilation.
- A3.1.5 Avoid buildup of vapors.

A3.1.6 Eliminate all sources of ignition, especially non-explosion-proof electrical devices and heaters.

A3.1.7 Avoid prolonged breathing of vapor or spray mist.

A3.2 *Physical Hazards*:

- A3.2.1 High-speed rotating equipment.
- A3.2.2 Electrical shock.
- A3.2.3 High-temperature surfaces.

A4. THE ROLE OF THE TEST MONITORING CENTER

A4.1 The ASTM TMC is a nonprofit organization located at 6555 Penn Ave., Pittsburgh, PA 15206-4489. It is staffed to administer engineering studies; conduct laboratory visits; perform statistical analysis of test; to blend, store, and ship reference oils; and to provide associated administrative functions connected with the referencing and calibration of various lubricant tests. The TMC maintains a close connection with test sponsors, test developers, the surveillance panels, and the testing laboratories. The management of these functions is vested in the Test Monitoring Board, whose members are elected by Subcommittee D02.B. The TMC operates under the ASTM Charter and its associated bylaws and regulations, the bylaws of Committee D02 and Subcommittee D02.B, and the Rules and Regulations of the Test Monitoring Board. The operating income of the TMC is obtained from fees levied on the reference oils supplied and on the conduct of the calibration tests. These fees are set by Subcommittee D02.B, and are regularly reviewed.

A4.2 *Information Letters*:

A4.2.1 It occasionally becomes necessary to change a test procedure and to notify test laboratories of the change before the change can be considered by Subcommittee D02.B on Automotive Lubricants or Committee D02 on Petroleum Products and Lubricants. In such a case, the TMC will issue an Information Letter. Subsequently, prior to each semiannual Committee D02 meeting, the accumulated Information Letters are balloted in Subcommittee D02.B. This ballot is reviewed at the Subcommittee D02.B meeting, and the actions taken are then considered by Committee D02. In this way, the ASTM due process procedures are applied to the Information Letters.

A4.2.2 The review of an Information Letter prior to its original issue will differ in accordance with its nature. In the

case of an Information Letter that does not affect test results, such as notification of a part number change, the TMC is authorized to issue an Information Letter. A survey or study conducted by the Surveillance Panel resulting in a recommendation for a change in hardware or procedure may result in the issuance of an Information Letter. If urgent changes to hardware or procedure are obviously necessary, the test sponsor and the TMC may issue an Information Letter and present it for approval, with the background and data, for approval by the Surveillance Panel prior to the next semiannual D02 meeting.

A4.2.3 Authority for the issue of Information Letters was given by the Committee on Technical Committee Operations (COTCO) in 1984, as follows:

“COTCO recognizes that D-2 has a unique and complex situation. The use of Information Letters is approved provided that each letter (at its initial issue) contains a disclaimer to the effect that it has not obtained ASTM consensus. These Information Letters should be moved to such consensus as rapidly as possible.”

A4.3 *Test Monitoring Center Memoranda*—In addition to the Information Letter system, the TMC will provide information to the Surveillance Panel and to participating laboratories in the form of ASTM TMC memoranda. These are used to convey such information as batch approvals for test parts or materials, to clarify misunderstandings concerning the test procedure, to provide notes and suggestions for the collection and analysis of special data that the TMC may call for, or for any other matters having no direct effect on the test performance, results, or precision and bias.

A4.4 *Precision Data*—Test precision is established on the basis of reference oil (calibration) test results monitored by the ASTM TMC. Current data may be obtained from the TMC.

A5. L-60-1 TEST REPORT FORMS and DATA DICTIONARY

A5.1 The required report forms and data dictionary are available on the ASTM Test Monitoring Center web page at <http://astmtmc.cmu.edu/> or can be obtained in hard copy format from the TMC.

Form 0 Test Report Cover

Form 1	Reference Test Result Summary Page
Form 2	Non-Reference Test Result Summary Page
Form 3	Operational Summary
Form 4	Page Lost Time and Comments Sheet
Form 5	Gear Rating
Form 6	Operational Validity Summary

A6. CORRECTIONS TO NON-REFERENCE OIL TESTS FOR INDUSTRY SEVERITY

A6.1 *Viscosity Increase*—Adjust end of test (EOT) viscosity increase results for industry severity. Transform EOT viscosity increase by taking the natural log of the viscosity increase result. Record the transformed viscosity increase result on the Non-Reference Test Results Summary Page (Form 2, Annex A5). Add -0.1178 to the transformed results and record this value on the Non-reference Oil Ratings Summary page in the Corrected Transformed Results space. Convert the corrected viscosity increase result to original units. Record this value in the Final Original Unit Result space.

A6.2 *Pentane Insolubles*—Adjust EOT pentane insolubles results for industry severity. Transform EOT pentane insolubles by taking the natural log of the pentane insolubles result. Record the transformed pentane insolubles result on the Non-Reference Test Results Summary Page (Form 2, Annex A5). Add -0.4445 to the transformed results and record this value on the Non-reference Oil Ratings Summary page in the Corrected Transformed Results space. Convert the corrected pentane insolubles result to original units. Record this value in the Final Original Unit Result space.

A6.3 *Toluene Insolubles*—Adjust EOT toluene insolubles results for industry severity. Transform EOT toluene insolubles by taking the natural log of the toluene insolubles result. Record the transformed toluene insolubles result on the Non-Reference Test Results Summary Page (Form 2, Annex A5). Add 0.0000 to the transformed results and record this value on

the Non-reference Oil Ratings Summary page in the Corrected Transformed Results space. Convert the corrected toluene insolubles result to original units. Record this value in the Final Original Unit Result space.

A6.4 *Average Carbon/Varnish*—Adjust EOT average carbon/varnish results for industry severity. Transform EOT average carbon/varnish by taking the natural log of the quantity of the average carbon/varnish result divided by ten minus the average carbon/varnish result. Record the transformed average carbon/varnish result on the Non-Reference Test Results Summary Page (Form 2, Annex A5). Add 0.0000 to the transformed results and record this value on the Non-reference Oil Ratings Summary page in the Corrected Transformed Results space. Convert the corrected average carbon/varnish result to original units. Record this value in the Final Original Unit Result space.

A6.5 *Average Sludge*—Adjust EOT average sludge results for industry severity. Transform EOT average sludge by taking minus the natural log of ten minus the average sludge result. Record the transformed average sludge result on the Non-Reference Test Results Summary Page (Form 2, Annex A5). Add 0.0000 to the transformed results and record this value on the Non-reference Oil Ratings Summary page in the Corrected Transformed Results space. Convert the corrected average sludge result to original units. Record this value in the Final Original Unit Result space.

A7. ALTERNATOR LOAD CIRCUIT

A7.1 Fig. A7.1 is a diagram of the modified 10.SI alternator load circuit.

STANDARD 10-SI SERIES ALTERNATOR

MODIFIED 10-SI SERIES ALTERNATOR

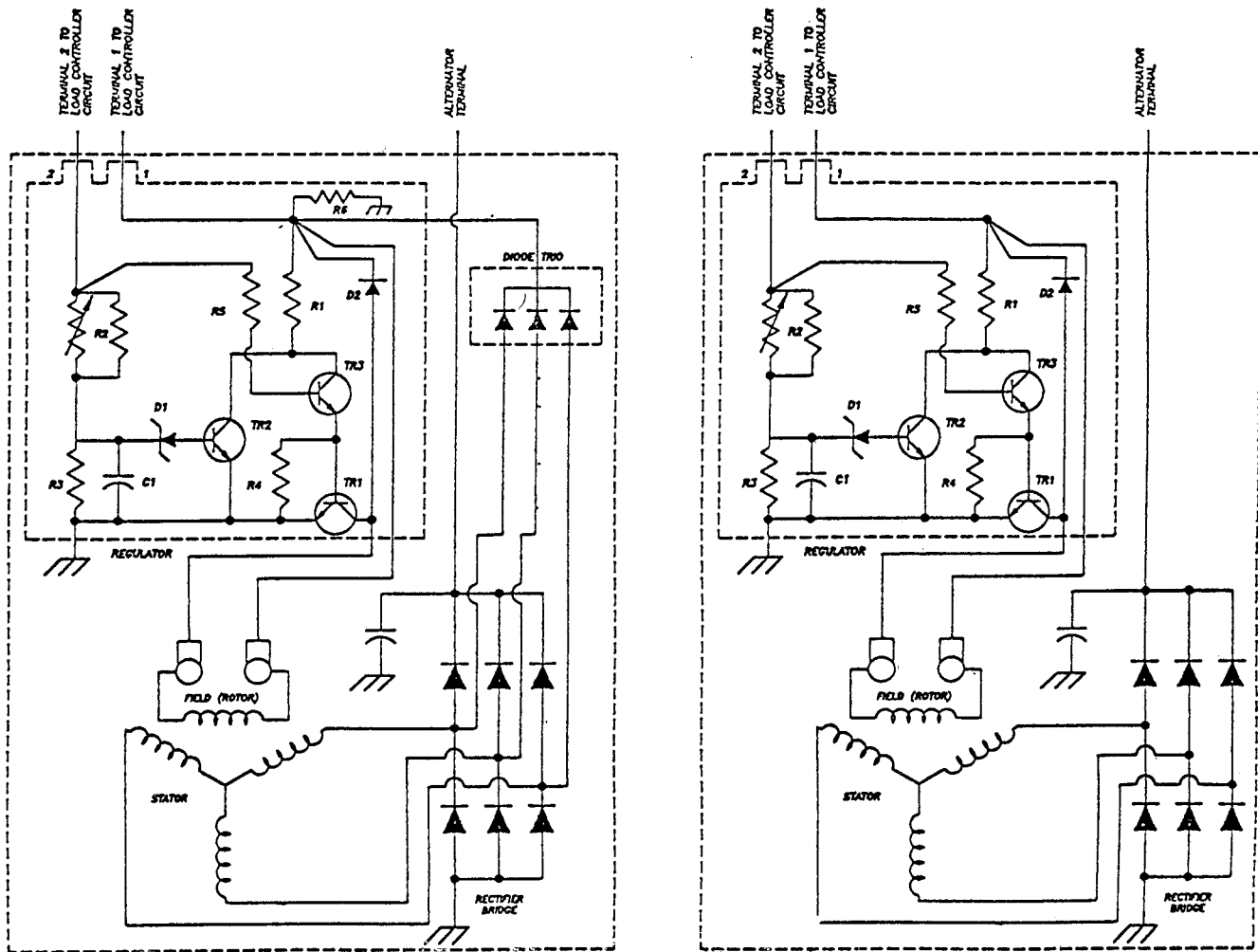

FIG. A7.1 Diagram of the Modified 10-SI Alternator Load Circuit

A8. CONTROL CHART TECHNIQUE FOR SEVERITY ADJUSTMENT (SA)

A8.1 Viscosity Increase SA—Apply an exponentially weighted moving average (EWMA) technique to standardized calibration test Viscosity Increase results. Convert results to transformed units by using the formula $\ln(\text{Viscosity Increase})$. Standardize transformed values using Δ/s ((result - target)/standard deviation). The targets and standard deviations for current reference oils are published by the ASTM TMC.

A8.1.1 Include all operationally valid reference tests in a stand control chart. Chart tests in order of completion date and time. A minimum of two tests is required to initialize a control chart. Calculate EWMA values using Eq A8.1.

$$Z_i = 0.2(Y_i) + 0.8(Z_{i-1}) \quad (A8.1)$$

where:

$Z_0 = 0$ and Y_i = standardized test result, and
 Z_i = EWMA of the standardized test result at test order i .

If the absolute value of the EWMA, rounded to three places after the decimal, exceeds 0.653, then apply an SA to subsequent non-reference oil results.

A8.1.2 The following example illustrates the application of Eq A8.1 for determining the application of Viscosity Increase SA.

$$Z_i = 0.694 \text{ and } Y_2 = 1.247 \quad (A8.2)$$

$$EWMA = 0.2(1.247) + 0.8(0.694) = 0.805$$

A8.1.2.1 Since $|0.805| > 0.653$, apply an SA to subsequent non-reference oil tests. Multiply 0.805 by 0.150. This value (0.150) represents the pooled Viscosity Increase standard deviation of oils 131-3 and 143. Multiply this result by -1 and round to four places after the decimal. Record this value on the Test Results Summary of the test report in the space for Viscosity Increase SA. Add this value to the transformed, corrected, non-reference oil Viscosity Increase result and

record this value in the Final Transformed result space on the Test Results Summary. Find the antilog and round to two places after the decimal. Enter this number on the Test Results Summary of the test report in the space for the Final Original Unit Viscosity Increase result. An SA will remain in effect until the next reference test. At that time, calculate a new EWMA.

A8.2 Pentane Insolubles SA—Apply an EWMA technique to standardized calibration test Pentane Insolubles results. Convert results to transformed units by using the formula $\ln(\text{Pentane Insolubles})$. Standardize transformed values using $\text{delta/s} = ((\text{result} - \text{target})/\text{standard deviation})$. The targets and standard deviations for current reference oils are published by the ASTM TMC.

A8.2.1 Include all operationally valid reference tests in a stand control chart. Chart tests in order of completion date and time. A minimum of two tests is required to initialize a control chart. Calculate EWMA values using Eq A8.1. If the absolute value of the EWMA (rounded to three places after the decimal) exceeds 0.653, then apply an SA to subsequent non-reference oil results.

A8.2.2 The following example illustrates the use of Eq A8.1 for determining the application of a Pentane Insolubles SA.

$$Z_1 = 0.570 \text{ and } Y_2 = 1.195 \quad (\text{A8.3})$$

$$\text{EWMA} = 0.2(1.195) + 0.8(0.570) = 0.695$$

A8.2.2.1 Since $|0.695| > 0.653$, apply an SA to subsequent non-reference oil tests. Multiply 0.695 by 0.730. This value (0.730) is the standard deviation of oil 131-3. Multiply this result by -1 and round to four places after the decimal. Record this value on the Test Results Summary page of the test report in the space for Pentane Insolubles SA. Add this value to the corrected, transformed, non-reference oil Pentane Insolubles result and enter this value in the space for the Final Transformed result. Find the antilog and round to two places after the decimal. Enter this number on the Test Results Summary of the test report in the space for the Final Original Unit Pentane Insolubles result. An SA will remain in effect until the next reference test. At that time, calculate a new EWMA.

A8.3 Toluene Insolubles SA—Apply an EWMA technique to standardized calibration test Toluene Insolubles results. Convert results to transformed units by using the formula $\ln(\text{Toluene Insolubles})$. Standardize transformed values using $\text{delta/s} = ((\text{result} - \text{target})/\text{standard deviation})$. The targets and standard deviations for current reference oils are published by the ASTM TMC.

A8.3.1 Include all operationally valid reference tests in a stand control chart. Chart tests in order of completion date and time. A minimum of two tests is required to initialize a control chart. Calculate EWMA values using Eq A8.1. If the absolute value of the EWMA (rounded to three places after the decimal) exceeds 0.653, then apply an SA to subsequent non-reference oil results.

A8.3.2 The following example illustrates the use of Eq A8.1 for determining the application of a Toluene Insolubles SA.

$$Z_1 = -0.572 \text{ and } Y_2 = -1.469 \quad (\text{A8.4})$$

$$\text{EWMA} = 0.2(-1.469) + 0.8(-0.572) = -0.751$$

A8.3.2.1 Since $| -0.751 | > 0.653$, apply an SA to subsequent non-reference oil tests. Multiply -0.751 by 0.750. This value (0.750) is the standard deviation of oil 131-3. Multiply this result by -1 and round to four places after the decimal. Record this value on the Test Results Summary of the test report in the space for Toluene Insolubles SA. Add this value to the transformed, corrected, non-reference oil result and enter this value in Final Transformed result space. Find the antilog and round to two places after the decimal. Enter this number on the Test Results Summary of the test report in the space for the Final Original Unit result. An SA will remain in effect until the next reference test. At that time, calculate a new EWMA.

A8.4 Average Carbon Varnish SA—Apply an EWMA technique to standardized calibration test Carbon/Varnish results. Convert results to transformed units by using the formula $\ln(\text{Carbon/Varnish}/(10 - \text{Carbon/Varnish}))$. Standardize transformed values using $\text{delta/s} = ((\text{result} - \text{target})/\text{standard deviation})$. The targets and standard deviations for current reference oils are published by the ASTM TMC.

A8.4.1 Include all operationally valid reference tests in a stand control chart. Chart tests in order of completion date and time. A minimum of two tests is required to initialize a control chart. Calculate EWMA values using Eq A8.1. If the absolute value of the EWMA (rounded to three places after the decimal) exceeds 0.653, then apply an SA to subsequent non-reference oil results.

A8.4.2 The following example illustrates the use of Eq A8.1 for determining the application of a Carbon/Varnish SA.

$$Z_1 = 0.667 \text{ and } Y_2 = -1.062 \quad (\text{A8.5})$$

$$\text{EWMA} = 0.2(1.062) + 0.8(0.667) = 0.746$$

A8.4.2.1 Since $|0.746| > 0.653$, apply an SA to subsequent non-reference oil tests. Multiply 0.746 by 0.450. This value (0.450) represents the pooled Carbon/Varnish standard deviation of oils 143 and 148. Multiply this result by -1 and round to four places after the decimal. Record this value on the Test Results Summary of the test report in the space for Carbon/Varnish SA. Add this value to the transformed, corrected, non-reference oil result and record this value in the Final Transformed result space. Convert to merit units by using the formula $10 \times (\exp(\text{Carbon/Varnish})/1 + \exp(\text{Carbon/Varnish}))$ and round to two places after the decimal. Enter this number on the Test Results Summary of the test report in the space for the Final Original Unit result. An SA will remain in effect until the next reference test. At that time, calculate a new EWMA.

A8.5 Average Sludge SA—Apply an EWMA technique to standardized calibration test Average Sludge results. Convert results to transformed units by using the formula $-1 \times \ln(10 - \text{Average Sludge})$. Standardize transformed values using $\text{delta/s} = ((\text{result} - \text{target})/\text{standard deviation})$. The targets and standard deviations for current reference oils are published by the ASTM TMC.

A8.5.1 Include all operationally valid reference tests in a stand control chart. Chart tests in order of completion date and time. A minimum of two tests is required to initialize a control chart. Calculate EWMA values using Eq A8.1. If the absolute

value of the EWMA (rounded to three places after the decimal) exceeds 0.653, then apply an SA to subsequent non-reference oil results.

A8.5.2 The following example illustrates the use of Eq A8.1 for determining the application of an Average Sludge SA.

$$Z_1 = -0.541 \text{ and } Y_2 = -1.197 \quad (\text{A8.6})$$

$$\text{EWMA} = 0.2(-1.197) + 0.8(-0.541) = -0.672$$

A8.5.2.1 Since $|0.672| > 0.653$, apply an SA to subsequent non-reference oil tests. Multiply -0.672 by 0.160 . This value (0.160) represents the pooled Average Sludge standard deviation of oils 143 and 148. Multiply this result by -1 and round to four places after the decimal. Record this value on the Test Results Summary of the test report in the space for Average Sludge SA. Add this value to the transformed, corrected, non-reference oil result and record this value in the Final Transformed result space. Convert to merit units using the formula $10 \cdot (\exp(-\text{Average Sludge}))$ and round to two places after the decimal. Enter this number on the Test Results Summary of the test report in the space for the Final Original Unit result. An SA will remain in effect until the next reference test. At that time, calculate a new EWMA.

A9. GEAR HOLDER APPARATUS

A9.1 Fig. A9.1 and Fig. A9.2 are diagrams of the gear holders used to prepare the test gears.

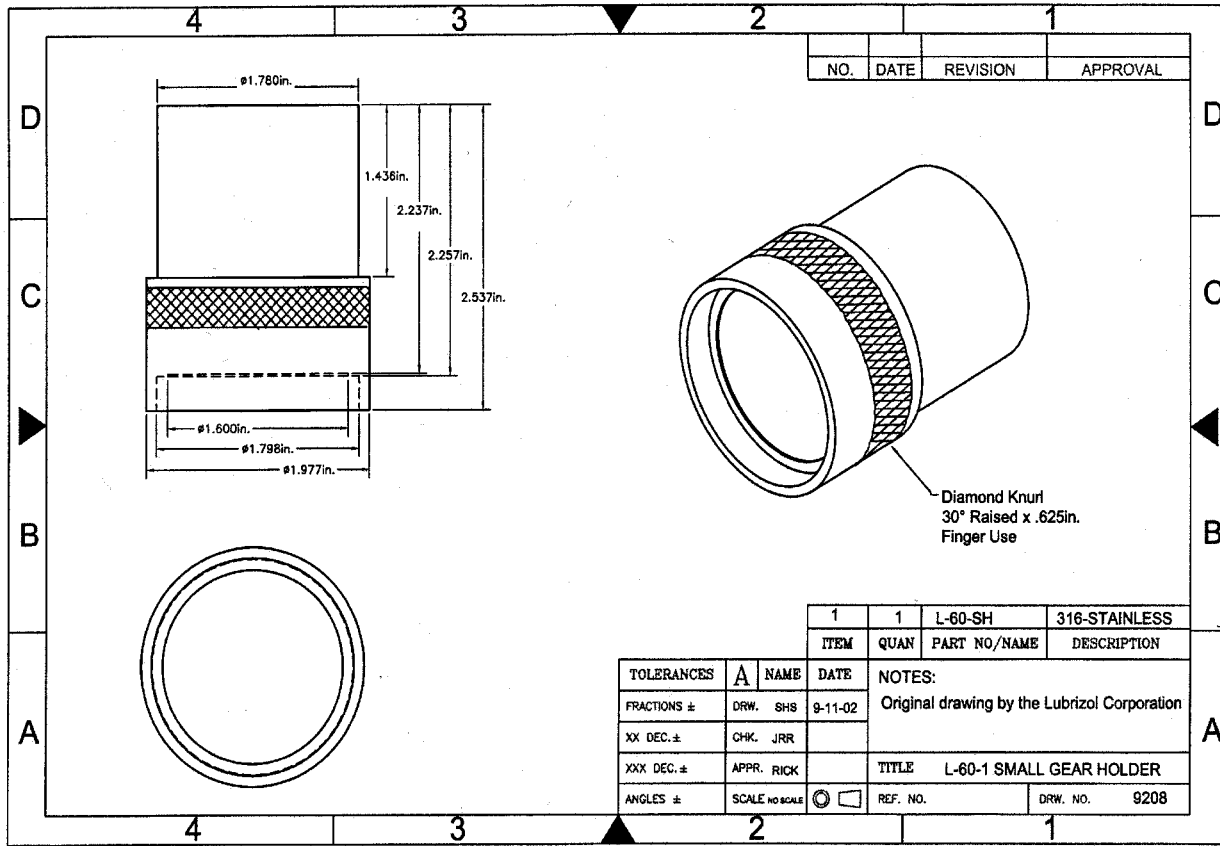

FIG. A9.1 Small Gear Holder

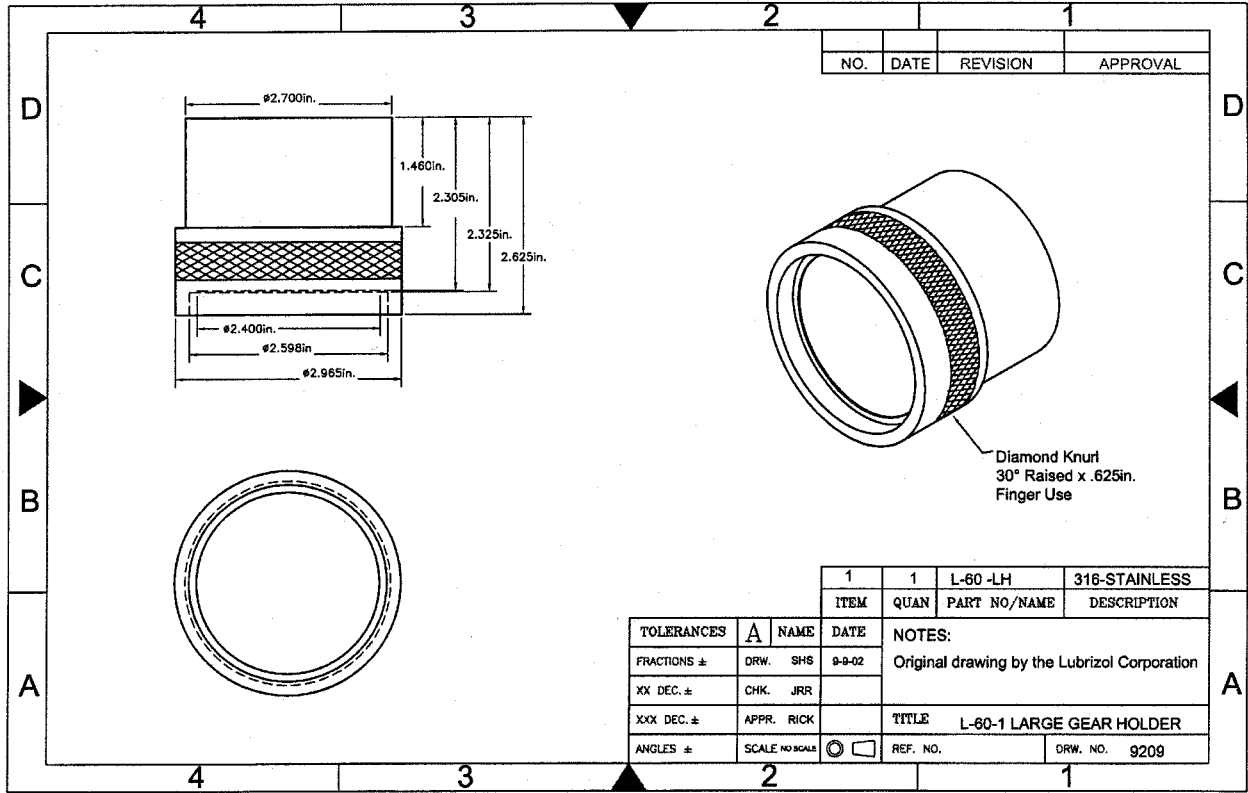

FIG. A9.2 Large Gear Holder

ASTM International takes no position respecting the validity of any patent rights asserted in connection with any item mentioned in this standard. Users of this standard are expressly advised that determination of the validity of any such patent rights, and the risk of infringement of such rights, are entirely their own responsibility.

This standard is subject to revision at any time by the responsible technical committee and must be reviewed every five years and if not revised, either reapproved or withdrawn. Your comments are invited either for revision of this standard or for additional standards and should be addressed to ASTM International Headquarters. Your comments will receive careful consideration at a meeting of the responsible technical committee, which you may attend. If you feel that your comments have not received a fair hearing you should make your views known to the ASTM Committee on Standards, at the address shown below.

This standard is copyrighted by ASTM International, 100 Barr Harbor Drive, PO Box C700, West Conshohocken, PA 19428-2959, United States. Individual reprints (single or multiple copies) of this standard may be obtained by contacting ASTM at the above address or at 610-832-9585 (phone), 610-832-9555 (fax), or service@astm.org (e-mail); or through the ASTM website (www.astm.org).