



Designation: **D 5800 – 03a4**

An American National Standard

Standard Test Method for Evaporation Loss of Lubricating Oils by the Noack Method¹

This standard is issued under the fixed designation D 5800; the number immediately following the designation indicates the year of original adoption or, in the case of revision, the year of last revision. A number in parentheses indicates the year of last reapproval. A superscript epsilon (ϵ) indicates an editorial change since the last revision or reapproval.

1. Scope*

1.1 This test method covers three procedures for determining the evaporation loss of lubricating oils (particularly engine oils). Procedure A uses the Noack evaporative tester equipment; Procedure B uses the automated non-Woods metal Noack evaporative apparatus; and Procedure C uses Selby-Noack volatility test equipment. The test method relates to one set of operating conditions but may be readily adapted to other conditions when required.

1.2 Noack results determined using Procedures A and B show consistent differences. Procedure A gives slightly lower results versus Procedure B on formulated engine oils, while Procedure A gives higher results versus Procedure B on basestocks.

1.3 The values stated in SI units are to be regarded as the standard. The values given in parentheses are for information only.

1.4 *This standard does not purport to address all of the safety concerns, if any, associated with its use. It is the responsibility of the user of this standard to establish appropriate safety and health practices and determine the applicability of regulatory limitations prior to use.*

¹ This test method is under the jurisdiction of ASTM Committee D02 on Petroleum Products and Lubricants and is the direct responsibility of Subcommittee D02.06 on Analysis of Lubricants.

Current edition approved ~~Dec~~, May 1, 2003⁴. Published ~~January~~, June 2004. Originally approved in 1995. Last previous edition approved in 2003 as D 5800–03a.

*A Summary of Changes section appears at the end of this standard.

2. Referenced Documents

2.1 ASTM Standards:²

- D 4057 Practice for Manual Sampling of Petroleum and Petroleum Products
- D 4177 Practice for Automatic Sampling of Petroleum and Petroleum Products
- D 6299 Practice for Applying Statistical Quality Assurance Techniques to Evaluate Analytical Measurement System Performance
- D 6300 Practice for Determination of Precision and Bias Data for Use in Test Methods for Petroleum Products and Lubricants

2.2 DIN Standards:³

- DIN 1725 Specification for Aluminum Alloys
- DIN 12785 Specifications for Glass Thermometers

3. Terminology

3.1 Definitions of Terms Specific to This Standard:

- 3.1.1 *evaporation loss*—of a lubricating oil by the Noack method, that mass of volatile oil vapors lost when the oil is heated in a test crucible through which a constant flow of air is drawn.
- 3.1.2 *volatility, n*—the tendency of a liquid to form a vapor.

4. Summary of Test Method

4.1 A measured quantity of sample is placed in an evaporation crucible or reaction flask that is then heated to 250°C with a constant flow of air drawn through it for 60 min. The loss in mass of the oil is determined.

4.2 Interlaboratory tests have shown that Procedure A, Procedure B, and Procedure C yield essentially equivalent results, with a correlation coefficient of $R\text{-squared} = 0.996$. See the research report⁴ for the Selby-Noack interlaboratory study.

5. Significance and Use

5.1 The evaporation loss is of particular importance in engine lubrication. Where high temperatures occur, portions of an oil can evaporate.

5.2 Evaporation may contribute to oil consumption in an engine and can lead to a change in the properties of an oil.

5.3 Many engine manufacturers specify a maximum allowable evaporation loss.

5.4 Some engine manufacturers, when specifying a maximum allowable evaporation loss, quote this test method along with the specifications.

5.5 Procedure C, using the Selby-Noack apparatus, also permits collection of the volatile oil vapors for determination of their physical and chemical properties. Elemental analysis of the collected volatiles may be helpful in identifying components such as phosphorous, which has been linked to premature degradation of the emission system catalyst.

Procedure A

6. Apparatus

6.1 *Noack Evaporative Tester*, comprising the following:

6.1.1 *Electrically Heated Block Unit*, made from a malleable aluminum alloy (see DIN 1725, Sheet 1), insulated at the jacket and base against loss of heat. (**Warning**—This block is heated to 250°C.) The block is heated electrically by a base and jacket heater, having a total power consumption of 1 to 1.2 kW. In this respect the difference between both individual power consumption should not exceed 0.15 kW. In the center of the heating block, there is a circular recess to insert the evaporating crucible, the space between block and crucible being filled with Woods alloy or a suitable equivalent. Two catches on the block prevent the crucible from rising in the liquid metal bath. Two additional circular recesses at equal intervals from the center of the block are provided for the thermometers (see Fig. 1).

6.1.2 *Evaporating Crucible*, with screw cover. The crucible is made of stainless steel (see Fig. 2). Above the support ring is the thread for the cover. The nickel-plated brass cover is hermetically sealed to the crucible by an internal conical sealing surface (see Fig. 3). Three nozzles of hardened steel permit the air stream to pass through the cover. The extraction tube, which slopes downward, leads from a threaded and sealed connection in the center of the cover.

6.2 *Balance*, capable of weighing at least 200 g to the nearest 0.01 g.

6.3 *Crucible Clamp and Spanner*.

6.4 *Reamer*, 2-mm diameter.

6.5 *Ball Bearing*, 3.5-mm diameter.

² For referenced ASTM standards, visit the ASTM website, www.astm.org, or contact ASTM Customer Service at service@astm.org. For *Annual Book of ASTM Standards* volume information, refer to the standard's Document Summary page on the ASTM website.

³ Available from Deutsches Institut für Normung, Beuth Verlag GmbH, Burggrafen Strasse 6, 1000 Berlin 30, Germany.

⁴ Supporting data have been filed at ASTM International Headquarters and may be obtained by requesting Research Report RR: D02-1462.

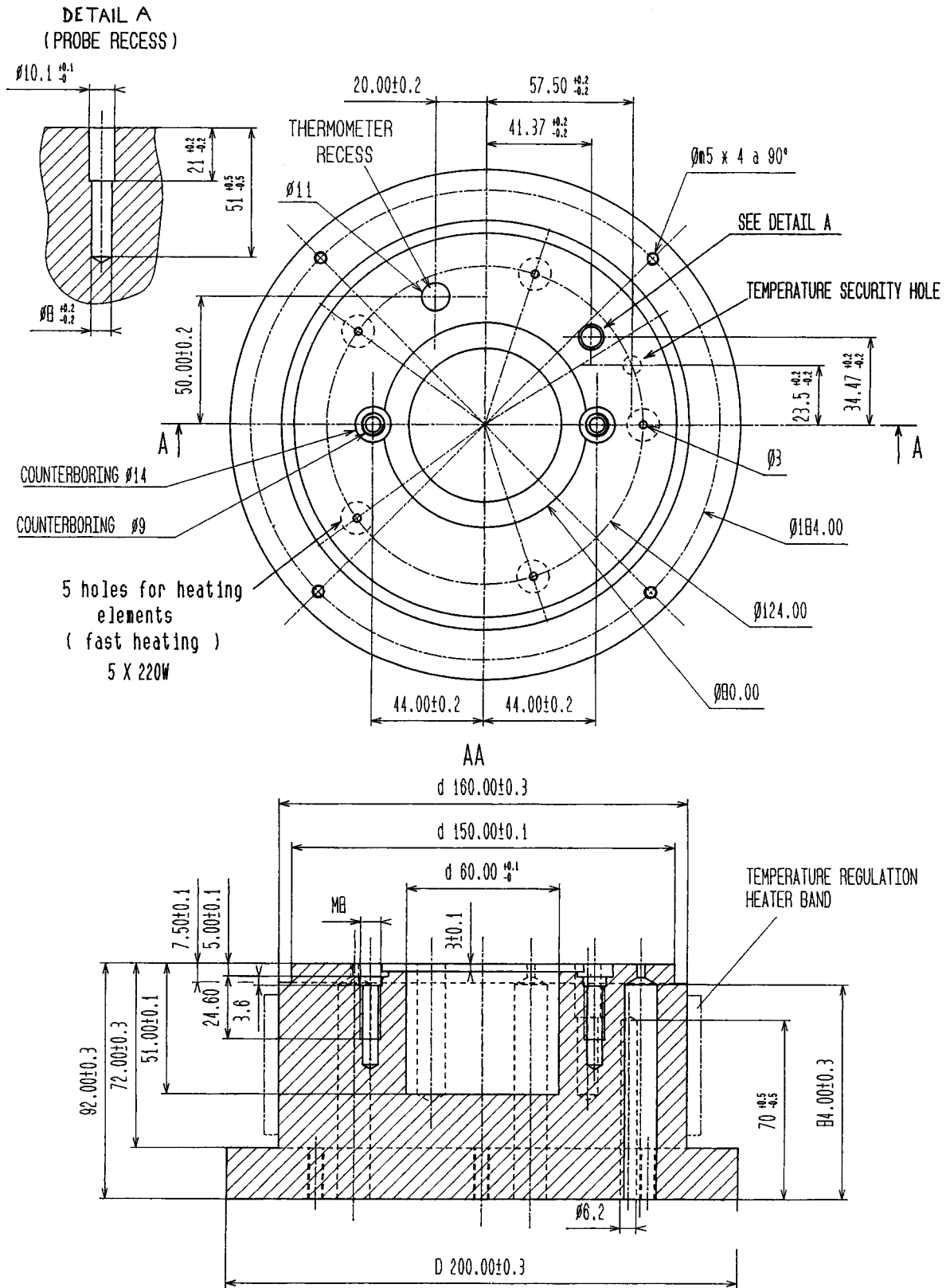

NOTE—All dimensions in millilitres.

FIG. 1 Heating Block

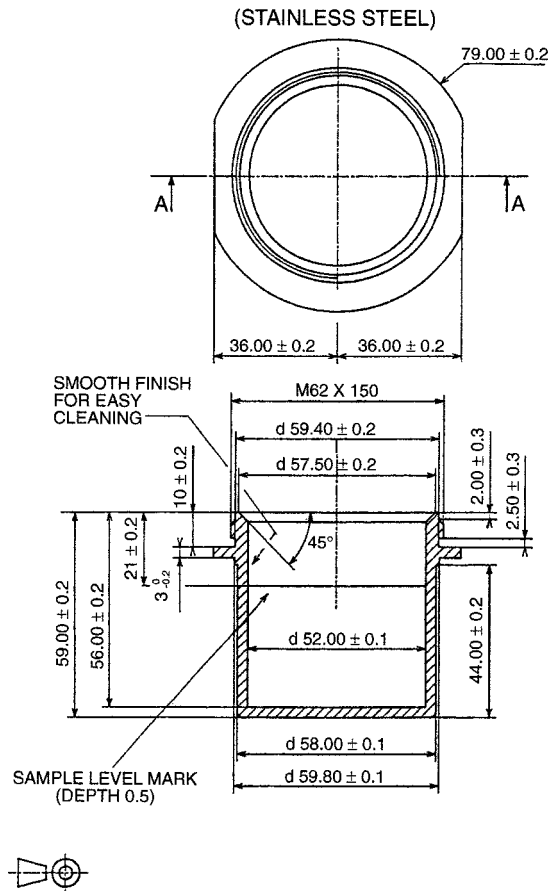

NOTE—All dimensions in millimetres.

FIG. 2 Crucible

6.6 *Thermometer*, M260 (see DIN 12785) or temperature sensing device capable of reading temperature to 0.1°C. The thermometer should be calibrated with appropriate procedure at appropriate frequency (generally every six months).

6.7 *Contact Type Control Thermometer* (for manual).

6.8 *Glass Y-piece*, an internal diameter of 4 mm. The upright arms, each 45-mm long, should form an angle such that the arm connected to the crucible extraction tube and the Y-piece form a straight line. The vertical arm is 60-mm long and beveled at 45°.

6.9 *Glass Delivery Tubes*, an internal diameter of 4 mm, each arm length 100 mm, beveled at 45° at ends entering and leaving the bottles.

6.9.1 Bent at an angle of approximately 80°.

6.9.2 Bent at an angle of approximately 100°, length to 20 mm of bottle base.

6.9.3 Bent at an angle of approximately 90°.

6.10 *Two Glass Bottles*, approximately 2-L capacity, fitted with rubber bungs bored to receive inlet and outlet tubes (see Fig. 4).

6.11 *Manometer*, inclined form, water-filled, precision 0.2 mm H₂O or suitable pressure sensor capable of measuring 20 ± 0.2 mm of H₂O (a 0 to 50-mm H₂O pressure transducer has been found to be satisfactory).

NOTE 1—Some manometers use water as the reference fluid, others may use a lower density fluid correlated to read in millimetres of water. Users should ensure that the manometer is filled with the correct density reference fluid.

6.12 *Glass T-Piece*, with bleed valve attached.

6.13 *Vacuum Pump*.

6.14 *Timer*, with accuracy of 0.2 s.

6.15 *Silicone Rubber Tubing*, cut to size, with an internal diameter of 4 mm.

6.15.1 40-mm long; three pieces required,

6.15.2 300-mm long, and

6.15.3 100-mm long.

NOTE 2—The use of automated equipment is permissible as long as it gives equivalent results specified in this test method. All hardware dimensions, make-up of the block, crucible, heat capacity, and so forth, and glassware must conform to the specifications given in this test method.

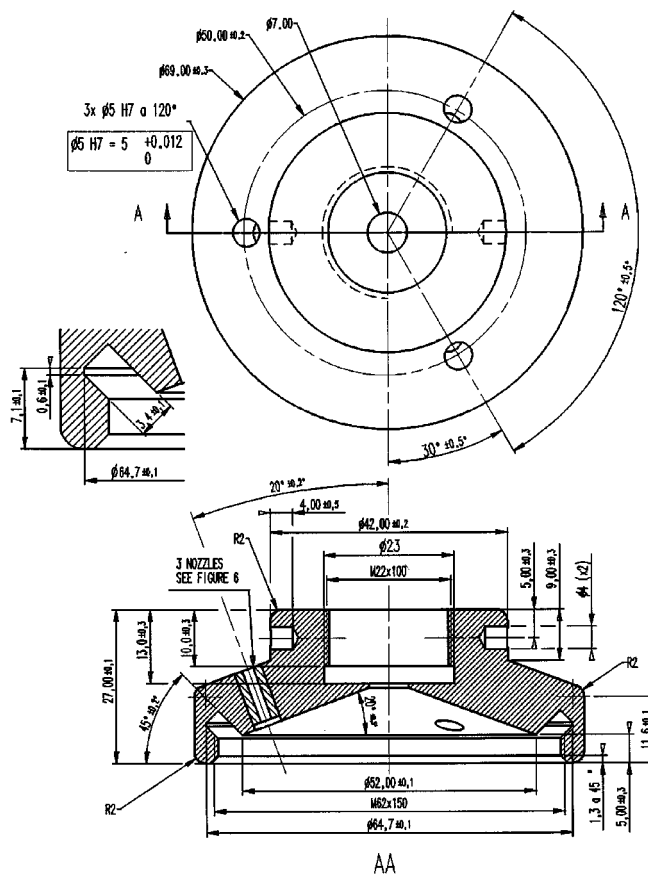

NOTE—All dimensions in millilitres.

FIG. 3 Cover

7. Reagents and Materials

7.1 *Cleaning Solvent*—A mixture of naphtha and toluene is recommended for the cleaning of the crucible. (**Warning**—Flammable, vapor harmful.) Overnight soaking may be necessary.

7.2 *Datum Oil RL 172*, (formerly RL-N) Reference Oil.

7.3 *Insulated Gloves*.

7.4 *Paint Brush*, such as a tinnerps acid brush (15 to 25-mm width).

7.5 *Woods Metal⁵ or suitable heat transfer material*—(**Warning**—Woods metal contains lead (25 %), bismuth (50 %), antimony (12.5 %), and cadmium (12.5 %); these have been found to be health hazardous. Avoid contact with skin at all times.)

8. Hazards

8.1 *Safety Hazards*—It is assumed that anyone using this test method will either be fully trained and familiar with all normal laboratory practices, or will be under the direct supervision of such a person. It is the responsibility of the operator to ensure that all local legislative and statutory requirements are met.

8.2 (**Warning**—Though the test method calls for a draft free area, the exhaust fumes from the evaporating oil must be ventilated to an outside source. Precaution shall be taken to avoid any possibility of fire or explosion.)

9. Preparation of Apparatus

9.1 A standard assembly of the apparatus is shown in Fig. 5. To avoid disturbing the thermal equilibrium, the apparatus shall be assembled in a draft free area and comply with Fig. 5 in dimensions and apparatus. (See 8.2.)

9.2 Add sufficient Woods metal or equivalent material to the recesses of the heating block so that, with the crucible and thermometer in place, the remaining spaces will be filled with the molten metal.

⁵ Woods metal, available from Aldrich Chemical Co., has been found satisfactory for this purpose. An equivalent may be used. Subcommittee D02.06 is evaluating less toxic alloys as alternatives.

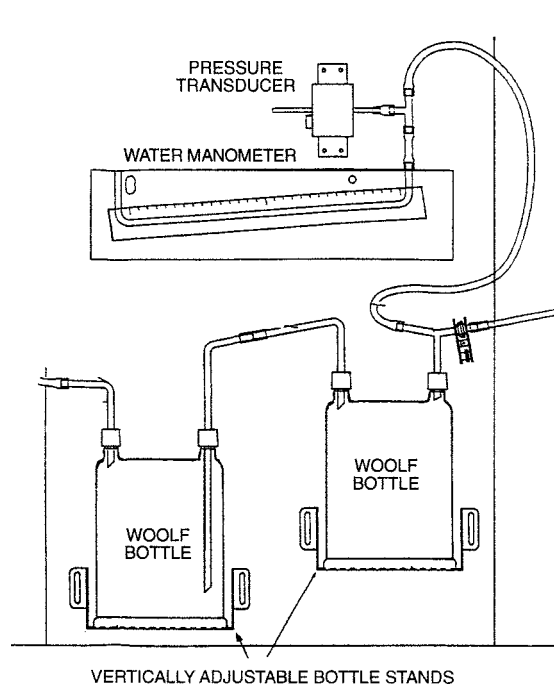

FIG. 4 Glassware

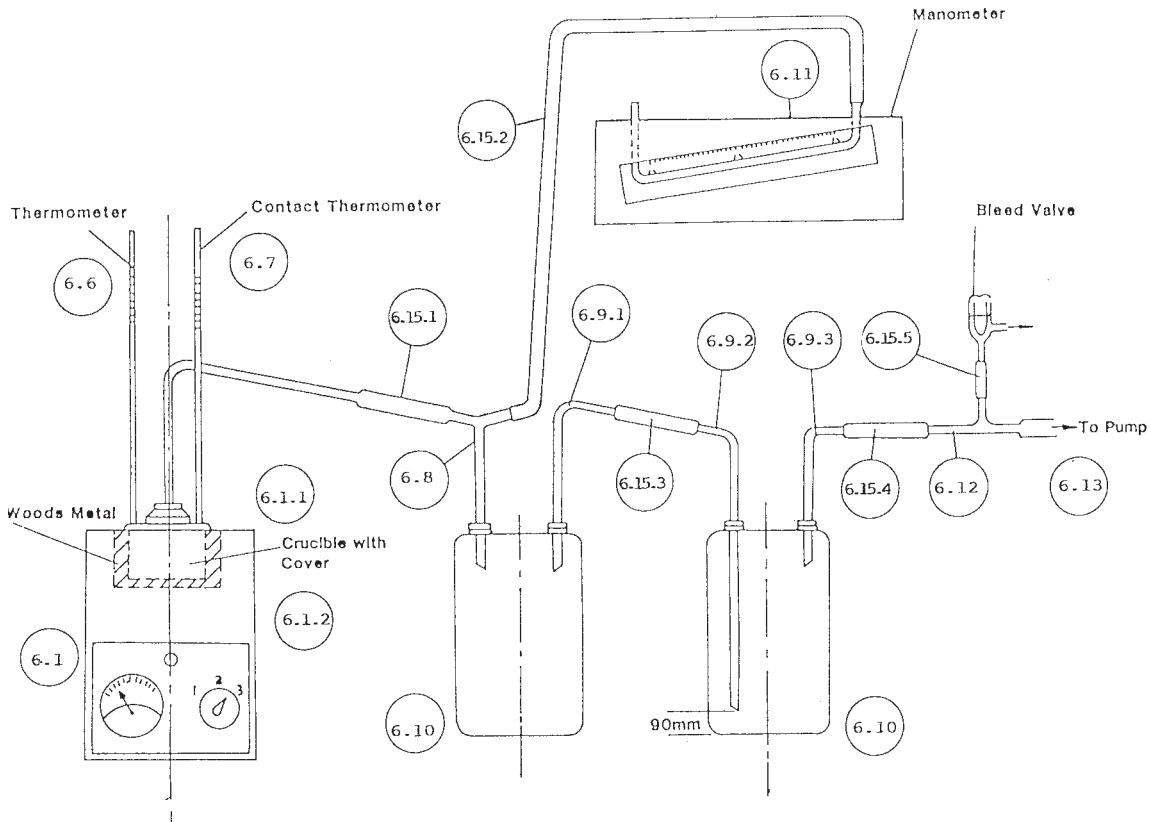

FIG. 5 Test Apparatus

9.3 Using the highest heating rate possible, raise the temperature of the heating block until the Woods metal is molten. Insert the thermometers with their bulbs touching the bottom of the recesses, and ensure that the contact thermometer is plugged in the back of the heating block. Adjust the power supplied to the heating block so that the temperature can be maintained at $250 \pm 0.5^\circ\text{C}$.

9.4 Assemble the remaining apparatus, less the crucible, as shown in Fig. 5.

9.5 Place an empty crucible in the heating block, securing the flange under the screw heads against the buoyancy of the Woods

metal. The level of the molten metal should be such that a trace of it can be seen at the flange of the crucible and the top of the heating block.

9.6 Check that the readings can be obtained on the manometer scale, or other measuring device, by connecting the crucible to the assembled apparatus. A reading of 20.0 ± 0.2 mm shall be obtained.

9.7 Disconnect and remove the crucible from the assembled apparatus.

9.8 Switch off the pump and the heating block and raise the crucible and the thermometers from the molten Woods metal. Using the brush, return any Woods metal clinging to the crucible to the heating block.

9.9 Clean the Y-piece and glass tubing to prevent a build up of condensate.

10. Verification

10.1 Switch on the pump and the heating block and ensure that the apparatus is assembled, minus the crucible, as shown in Fig. 5.

10.2 Check that the crucible and cover are free from lacquer.

10.2.1 After every test, clean the crucible and cover with solvent and allow to dry. Stubborn lacquer can be cleaned by abrasion from a glass bead~~ker~~ under pressure.

10.3 Pass the reamer through each of the three nozzles in the cover to ensure that they are clear. (**Warning**—Using a reamer with a diameter larger than 2 mm can enlarge the nozzles. This can lead to higher losses because of increased air flow.)

10.4 Run the ball bearing through the extraction tube to ensure that it is clear of dirt.

10.5 Weigh the empty crucible without its cover to the nearest 0.01 g.

10.6 Weigh into the crucible 65.0 ± 0.1 g of the Reference Oil.

10.7 Screw on the cover using the clamp and spanner.

10.8 Ensure the temperature of the heating block is at $250 \pm 0.5^\circ\text{C}$. Place the crucible in its recess in the heating block, securing the flange under the screw heads against the buoyancy of the Woods metal. Switch the control of the heating block to compensate for the heat capacity of the crucible. Immediately (in less than 5 s), connect the extraction tube of the crucible to the arm of the glass Y-piece, making a butt joint. Simultaneously, start the pump and the stopwatch and adjust the bleed valve to give a pressure differential of 20 ± 0.2 mm.

NOTE 3—When the crucible is in the test position, its flange should be flush with the top of the heating block. Any protrusion of the crucible flange above the heating block may suggest a buildup of Woods metal slag at the bottom of the heating block recess. The heating block and the thermometer recesses should be cleaned and the Woods metal replaced on a regular basis to avoid the accumulation of slag. Oxidized Woods metal will affect the heat transfer to the crucible and hence may have a deleterious effect on the results obtained.

10.9 Adjust the control on the heating block to maintain the block temperature approximately 5°C below the test temperature. Readjust the temperature control so that the test temperature is reestablished within 3 min of the start of the test.

NOTE 4—Temperature and pressure will be controlled automatically when automated equipment is used.

10.10 At the start of the test, constant attention shall be paid to maintaining the correct pressure. Once this becomes steady, usually within 10 to 15 min, check periodically that the temperature and pressure differential remain constant throughout the period of the test.

10.11 After $60 \text{ min} \pm 5 \text{ s}$, lift the crucible from the heating block, remove any adhering alloy, and place the crucible in a warm water bath to a depth of at least 30 mm. The time period from the end of the test to immersion of the crucible shall not exceed 60 s.

10.12 After 30 min, remove the crucible from the water, dry the outside, and carefully remove the lid.

10.13 Reweigh the crucible without the lid to the nearest 0.01 g.

10.14 Calculate to the nearest 0.1 % mass/mass (M/M) the evaporation loss of the ~~R~~ reference ~~o~~ oil.

10.15 Compare the result obtained against the given value for the ~~R~~ reference ~~o~~ oil. If the result is within 6 % of the value, repeat the procedure from 11.1, using the test sample.

10.16 If the result is not within 6 % of the given value, check that the apparatus complies with that shown in Fig. 5, and that the procedure has been adhered to. Check the calibration of the thermometer and pressure sensing device.

10.17 Re-check the evaporation loss of the reference oil.

NOTE 5—Condensate should not be allowed to build up in the 2-L glass bottles. These should be washed out with solvent before a maximum 1 cm of condensate collects.

NOTE 6—The equipment should be referenced approximately every ten tests if the test is used frequently. If the testing is infrequent, the equipment should be referenced before the first sample is run.

11. Procedure

11.1 Weigh into a tarred crucible 65 ± 0.1 g representative of the test sample to a precision of 0.01 g.

NOTE 7—Sample in accordance with Practice D 4057 or Practice D 4177.

11.2 Proceed as described in 10.7 to 10.12.

11.3 Calculate to the nearest 0.1 % M/M the evaporation loss of the sample.

12. Calculations and Results

12.1 Evaporation loss is obtained from the difference in weight before and after 1 h at 250°C.

$$\text{evaporation loss} = \frac{(B - A) - (C - A)}{B - A} \times 100 \tag{1}$$

where:

- A = empty crucible weight,
- B = crucible plus sample weight, and
- C = crucible plus sample after 1 h of heating.

13. Report

13.1 Report the following information:

13.1.1 The nearest 0.1 % M/M as evaporation loss (Test Method D 5800).

14. Precision and Bias

14.1 The interlaboratory round robin used manual, semi-automated, and automated equipment. The precision values were calculated on the statistical examinations of interlaboratory test results as follows.

14.1.1 *Repeatability*—A quantitative measurement of precision associated with single results obtained by the same operator with the same equipment in the same laboratory within a short interval of time. In the normal and correct operation of the test method, the following values were exceeded in only one case in twenty.

$$\text{Repeatability} = 5.8 \% \times \text{average M/M evaporation loss} \tag{2}$$

14.1.2 *Reproducibility*—A quantitative measure of precision with single results obtained in different laboratories on identical test material. In the normal and correct operation of the test, the following values were exceeded in only one case in twenty.

$$\text{Reproducibility} = 18.3 \% \times \text{average M/M evaporation loss} \tag{3}$$

14.2 The procedure in this test method has no bias because the value of the volatility is defined only in terms of this test method.

Procedure B Non-Woods Metal Apparatus

15. Introduction

15.1 The following procedure describes an automated test method that uses the same principle, and the same crucible as Procedure A. Only the heat transfer to the sample is different. It does not use Woods alloy, and the sample temperature is directly monitored.

16. Apparatus

16.1 *Noack Evaporative Tester* (see Fig. 6), comprising the following:

16.1.1 *Heating Block Unit*, electrically heated by base and jacket heaters, having a total power consumption sufficient to ensure a specimen temperature profile similar to the one recorded in the specimen when heated with the Woods metal heater block. In the center of the heating block, there is a circular recess to insert the evaporative crucible. The jacket heater is configured to ensure a direct contact with the crucible. A mechanism is provided to open the jaws for crucible insertion. Two catches on the block prevent the crucible from rising, and the base heater is spring loaded to ensure a direct contact with the crucible.

16.1.2 *Evaporative Crucible*, with screw cover (see Fig. 7). The crucible is made of stainless steel (see Fig. 8). Above the support ring is the thread for the cover. The nickel-plated brass cover (see Fig. 9) is hermetically sealed to the crucible by an

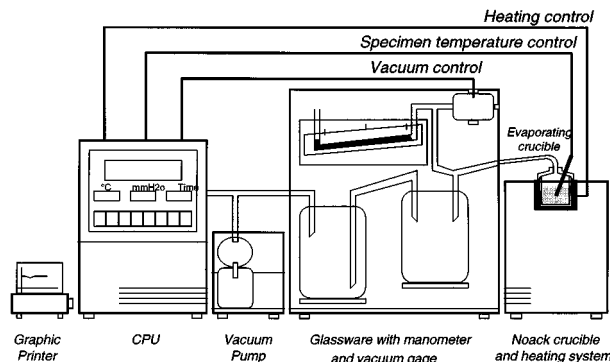

FIG. 6 Automated Non-Woods Metal Noack Evaporative Apparatus

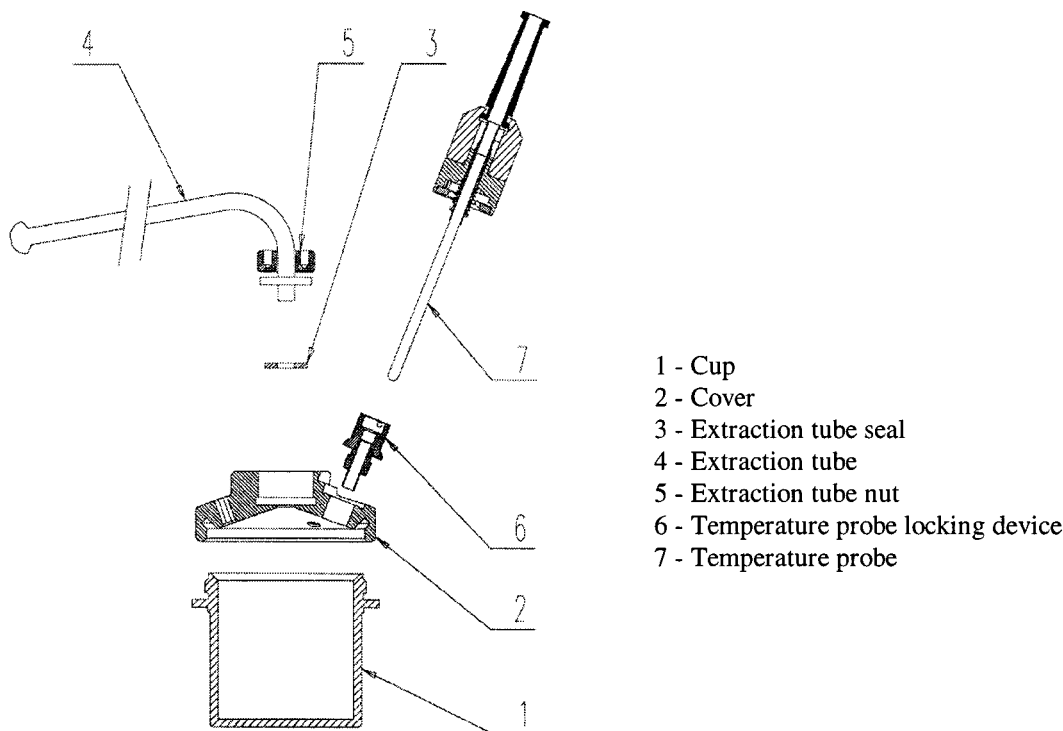

FIG. 7 Crucible with Temperature Probe

internal conical sealing surface. Three nozzles of hardened steel (see Fig. 10) permit the air stream to pass through the cover. The extraction tube (see Figs. 11 and 12), which slopes downward, leads from a threaded and sealed connection in the center of the cover.

16.1.3 *Temperature Probe*—The specimen temperature measuring device shall have an accuracy of 0.5°C, or better, and a resolution of 0.1°C, or better. The probe is provided with a calibration certificate of 250.0°C with a precision of ±0.1°C. Its diameter is 4 mm, and its position is as indicated in Fig. 8. It should be calibrated with appropriate procedure at appropriate frequency (minimum once a year).

16.2 *Balance*, capable of weighing at least 500 g to the nearest 0.01 g.

16.3 *Crucible Clamp and Spanner*.

16.4 *Reamer*, 2-mm diameter.

16.5 *Ball Bearing*, 3 to 5-mm diameter.

16.6 *Glassware Assembly*, strictly identical to the description in 6.6 to 6.12 and 6.15 of Procedure A.

16.7 *Vacuum Pump*.

16.8 *Central Processing Unit (CPU)*, capable of controlling the specimen temperature, the vacuum, the time, the heating, and the printing. The specimen is heated to $245.2 \pm 0.5^\circ\text{C}$ with the temperature profile recorded in the specimen when tested with a Woods metal apparatus (1 h at 250°C) with automatic test duration compensation. The automatic test duration compensation is used because a test may be started with a heating block at room temperature or at hot temperature when several tests are carried without cooling phase. The CPU automatically adjusts the pressure differential of 20 ± 0.2 mm. These conditions can be checked with the printed report.

16.9 *Printer*, to print the graphs of the specimen temperature and the vacuum recorded during the test.

17. Reagents and Materials

17.1 *Cleaning Solvent*—A mixture of naphtha and toluene is recommended for cleaning the crucible. (**Warning**—Flammable, vapor harmful.) Overnight soaking may be necessary.

17.2 *Noack Reference Fluid*—Oil having a known evaporative loss, the value of which is provided by the manufacturer.

17.3 *Insulated Gloves*.

17.4 *Drying Paper*.

18. Hazards

18.1 *Safety Hazards*—It is assumed that anyone using this test method will either be fully trained and familiar with all normal laboratory practices, or will be under the direct supervision of such a person. It is the responsibility of the operator to ensure that all local legislative and statutory requirements are met.

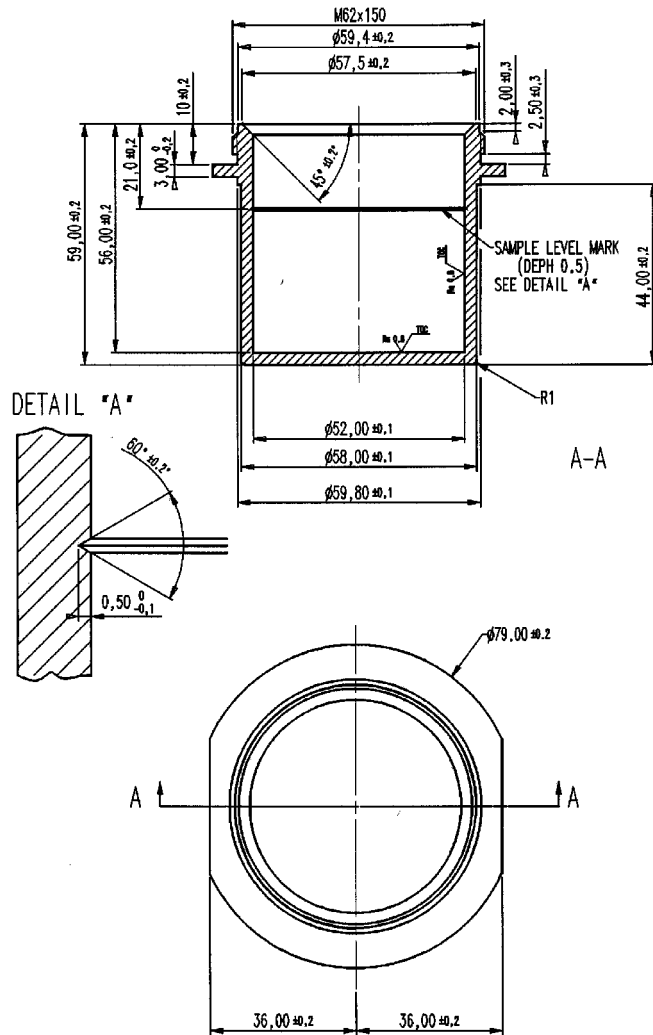

FIG. 8 Noack Cup (Detail 1 of Fig. 7)

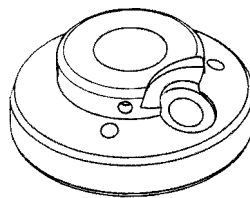

FIG. 9 Crucible Cover (Detail 2 of Fig. 7)

18.2 (**Warning**—Though the test method calls for a draft free area, the exhaust fumes from the evaporating oil must be ventilated to an outside source. Precaution shall be taken to avoid any possibility of fire or explosion.)

19. Preparation of Apparatus

19.1 A standard assembly of the apparatus is shown in Fig. 6. To avoid disturbing the thermal equilibrium, the apparatus shall be assembled in a draft free area and shall comply with Fig. 6 dimensions and apparatus. (See 18.2.)

19.2 Prepare the automated apparatus for operation in accordance with the manufacturer’s instructions for calibrating, checking, and operating the equipment.

19.3 Clean the glass bottles, the glass tubing, and the Y-piece to prevent a build up of condensate.

NOTE 8—Condensate should not be allowed to build up in the 2-L glass bottles. These should be washed out with solvent and dried before a maximum 2 cm of condensate collects.

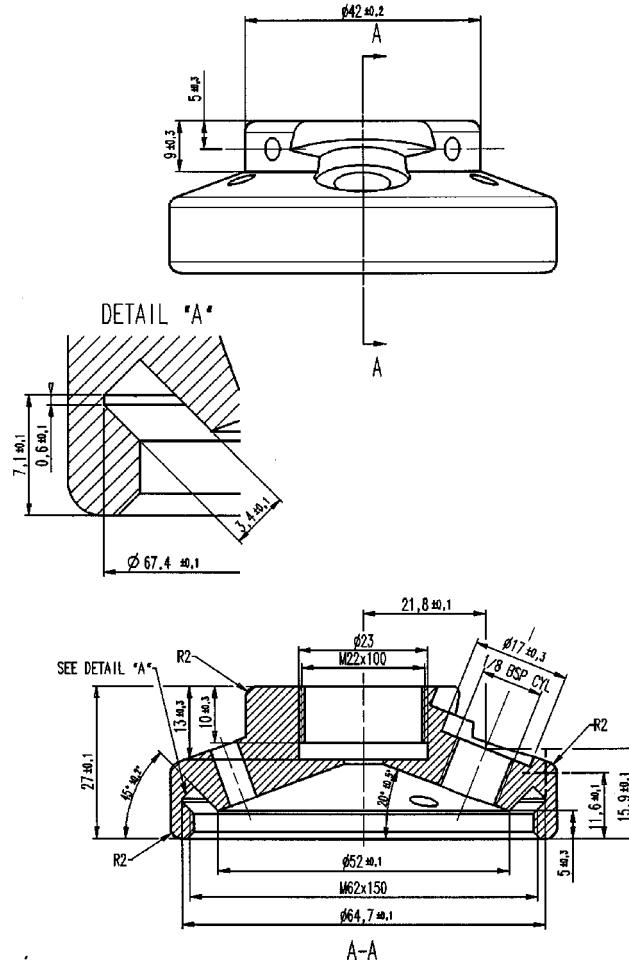

FIG. 9 Crucible Cover (continued)

20. Verification

20.1 Switch the instrument on a minimum of 30 min before running the test to allow temperature stabilization of measurement circuitry.

20.2 Make sure that the glassware assembly and the vacuum pump are cleaned and all the connections are sealed.

20.3 Thoroughly clean and dry all parts of the test cup and its accessories before starting the test. Check that the crucible and cover are free from lacquer. Stubborn lacquer should be removed by light abrasion with fine carborundum powder on a pad of cotton wool soaked in solvent or with a fibrous abrasive pad, followed by a rinse with solvent.

20.4 Pass the reamer through each of the three nozzles in the cover to ensure that they are clear. (**Warning**—Using a reamer with a diameter larger than 2 mm can enlarge the nozzles. This can lead to a wrong losses result due to increased air flow.)

20.5 Run the ball bearing through the extraction tube to ensure that it is clear of contaminants.

20.6 After the 30 min stabilization period, calibrate the temperature measuring device in accordance with the manufacturer's instructions.

20.7 Calibrate the vacuum measuring device in accordance with the manufacturer's instructions.

20.8 Weigh the empty cup without its cover to the nearest 0.01 g.

20.9 Weigh into the tared crucible 65.0 ± 0.1 g of $R_{\text{reference}}$ fluid to a precision of 0.01 g. This mass is called M_1 .

20.10 Screw on the cover; using the clamp and the spanner. During this phase, make sure that the specimen will never splash on the inside part of the cover. If this occurs, even only one time, the test shall be repeated from 20.3.

20.11 Connect the specimen temperature probe to the instrument.

20.12 Press down on the locking lever located on the front of the heating block. Place the crucible in the heating block. Rotate the crucible, securing the flange under the screw heads. Adjust the final position of the extraction tube so that it is located in front of the arm of the glass Y-piece, and release the locking lever.

20.13 Connect the extraction tube to the arm of the glass Y-piece, and secure the connection with the clamp. Be sure that the stainless extraction tube, the male connection, and the right arm of the Y-piece are properly aligned.

20.14 Start the test by pressing the ON key of the CPU. In default configuration, the printer is activated. If not, refer to the

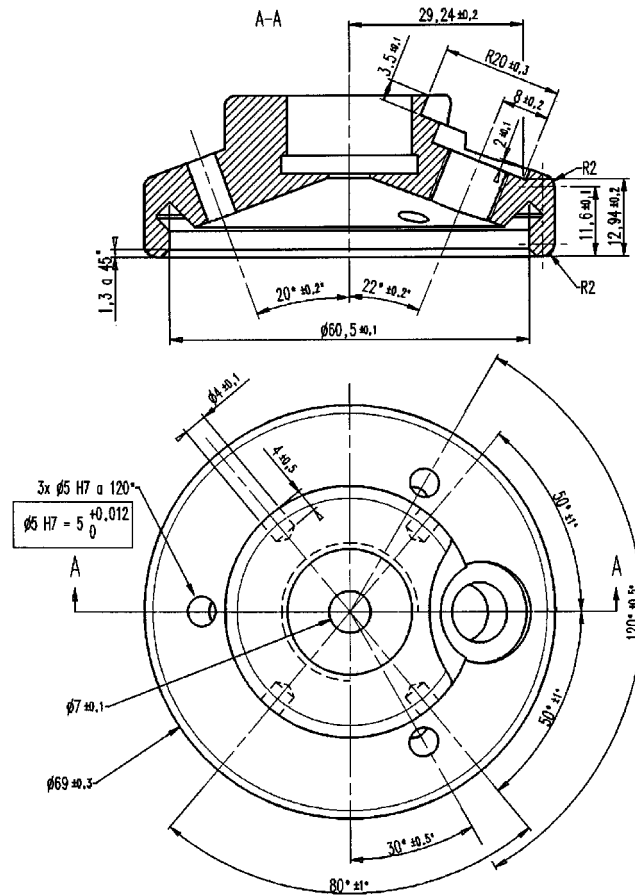

FIG. 9 Crucible Cover (continued)

instruction manual to activate the real time printing of the specimen temperature and the vacuum curves.

20.15 When the audible alarm signals the last 3 min of the test, stop the audible alarm by pressing on the OFF key. Stay in front of the equipment, and be prepared to disconnect the extraction tube.

20.16 After 60 min, the test is automatically stopped, and the end of the test alarm sounds. Remove the specimen temperature probe. Disconnect the extraction tube within 15 s maximum. Press down the locking lever. Remove the crucible. Stop the audible alarm by pressing on the OFF key.

20.17 Stand the crucible in a cold water bath to a minimum depth of 30 mm.

20.18 Check the printed report to ensure that the specimen temperature and the vacuum plotted curves stayed within the indicated limits. If one of the graph is not within the specified limits, check that the apparatus complies with the manufacturer's instruction and that the procedure has been adhered to. After these checks, rerun the test from 20.2.

20.19 After 30 min, remove the crucible from the water bath, dry the outside, and carefully remove the lid. This phase is very critical. Make sure that the sample is never in contact with the inside part of the lid.

NOTE 9—It is very important during the manipulation of the crucible, at the start and the end of the test, to not splash the internal face of the cover with the specimen in the cup. When this occurs, it leads to higher losses and *the test must be rerun*.

20.20 Reweigh the crucible without the lid to the nearest 0.01 g.

20.21 Calculate the M_2 mass by subtracting the empty cup mass from the mass measured in 20.19.

20.22 Calculate to the nearest 0.1 % M/M the evaporation loss of the R_reference_F_fluid, using the following equation:

$$[(M_1 - M_2)/M_1] \times 100 \quad (4)$$

where:

M_1 = specimen mass before the test, and

M_2 = specimen mass after the test at 245.2°C.

20.23 Compare the result obtained against the given value for the R_reference_F_fluid. If the result is within limits, proceed to Section 21.

20.24 If the result is not within the limits, check that the apparatus complies with the manufacturer's instruction and that the procedure has been adhered to.

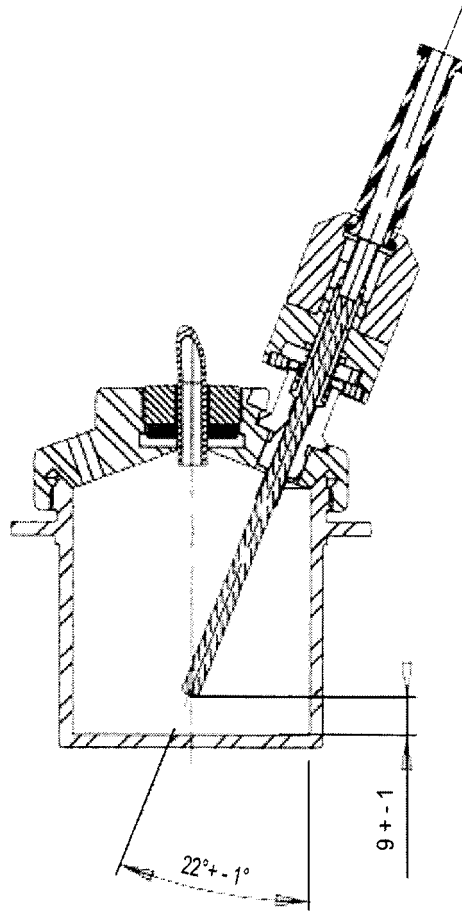

FIG. 10 Specimen Temperature Probe Positioning

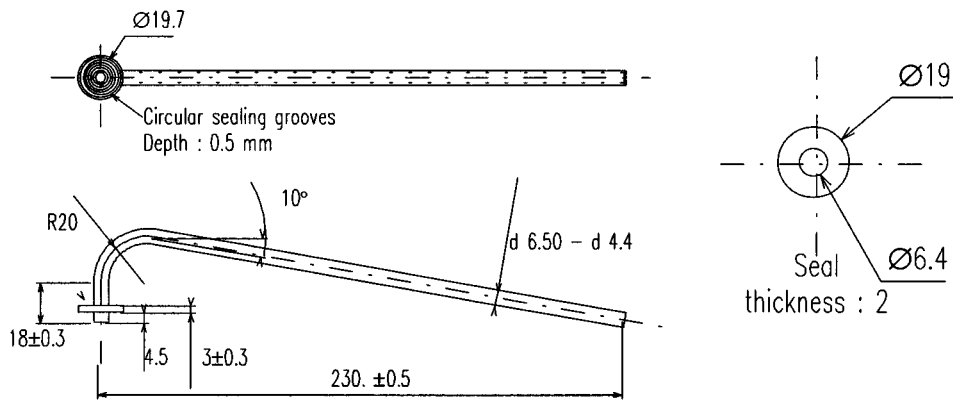

FIG. 11 Extraction Tube (Stainless Steel) with Its Seal (Details 3 and 4 of Fig. 7)

20.25 Recheck the evaporation loss of the $R_{reference}$ oil. To do so, proceed as described in 20.2.

21. Procedure

21.1 Weigh into a tared crucible 65 ± 0.1 g representative of test specimen to a precision of 0.01 g.

NOTE 10—Sample in accordance with Practice D 4057 or Practice D 4177.

21.2 Proceed as described in 20.3-20.20.

21.3 Calculate to the nearest 0.1 % M/M the evaporation loss of the specimen, using Eq 4.

22. Calculation

22.1 Evaporation loss is obtained from the difference in weight before and after test. The specimen is heated in accordance with the temperature profile recorded in the specimen when tested with a Woods metal apparatus (1 h at 250°C) with automatic test

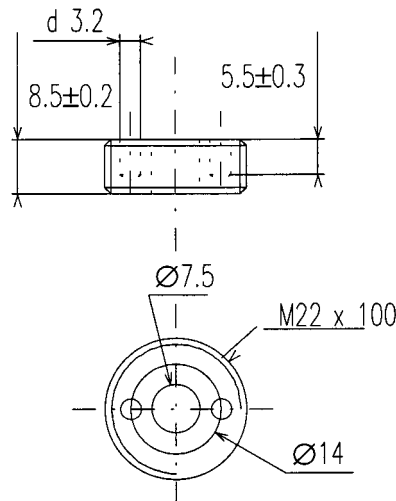

FIG. 12 Extraction Tube Nut (Stainless Steel) (Detail 5 of Fig. 7)

duration compensation. The automatic test duration compensation is used because a test may be started with a heating block at room temperature or at hot temperature when several tests are carried without cooling phase. The checking of these conditions can be done with the printed report. Calculate evaporation loss, using the following equation:

$$[(M_1 - M_2)/M_1] \times 100 \quad (5)$$

where:

$$M_1 = B - A,$$

$$M_2 = C - A,$$

A = empty crucible weight,

B = crucible plus specimen weight, and

C = crucible plus specimen after the test.

22.2 Some consistent differences in results determined using Procedures A and B have been observed depending on the type of sample tested. A test result obtained using one of the procedures can be transformed to an estimated result on the basis of the other procedure as follows:

22.2.1 *Formulated Engine Oils*—The following relationships are based on the round robin test results on formulated engine oils with volatilities in the range of 10 % to 22 % Noack:

$$\text{Value by Noack Procedure B} = 1.027 \times \text{Value by Noack Procedure A} \quad (6)$$

$$\text{Value by Noack Procedure B} = 1.027 \times \text{Value by Noack Procedure A} \quad (6)$$

$$\text{Value by Noack Procedure A} = 0.974 \times \text{Value by Noack Procedure B} \quad (7)$$

$$\text{Value by Noack Procedure A} = 0.974 \times \text{Value by Noack Procedure B} \quad (7)$$

The 95 % confidence limits for the regression coefficient in Eq 6 are 1.021 to 1.033; those for the coefficient in Eq 7 are 0.968 to 0.980.

22.2.2 The following relationships are based on round robin test results on basestocks with volatilities in the range of 4 % to 15 % Noack:

$$\text{Value by Noack Procedure B} = 0.955 \times \text{Value by Noack Procedure A} \quad (8)$$

$$\text{Value by Noack Procedure B} = 0.955 \times \text{Value by Noack Procedure A} \quad (8)$$

$$\text{Value by Noack Procedure A} = 1.048 \times \text{Value by Noack Procedure B} \quad (9)$$

$$\text{Value by Noack Procedure A} = 1.048 \times \text{Value by Noack Procedure B} \quad (9)$$

The 95 % confidence limits for the regression coefficient in Eq 8 are 0.950 to 0.959; those for the coefficient in Eq 9 are 1.043 to 1.053.

23. Report

23.1 Report the following information:

23.1.1 The nearest 0.1 % M/M as evaporation loss (Test Method D 5800, Procedure B).

23.2 Conversion of values from either D 5800 A or D 5800 B to the other:

23.2.1 Only if the nature of the test specimen is known with certainty, in other words, it is known to be either a basestock or a formulated engine oil, the evaporation loss calculated in 22.2.1 on the basis of either Procedure A or Procedure B may be converted to an equivalent result on the basis of the other procedure. The appropriate equation from those above should be selected and applied according to the type of the sample tested (formulated engine oil or basestock).

23.3 Report the converted result from Procedure A to B, or Procedure B to A to the nearest 0.1 m % as evaporation loss of the test sample as converted from the original procedure to the calculated basis procedure.

23.4 If the nature of the test specimen is not known as being either a basestock or a formulated engine oil, then the results of the test using D 5800 B must be identified as being run under D 5800 B and the value of percent evaporation so obtained will require additional information on the nature of the test specimen for calculations to be made to generate the standard value produced by D 5800 A.

23.4.1 Converted results should be reported as D 5800 A (converted from the results obtained by D 5800 B) or as D 5800 B (converted from the results obtained by D 5800 A).

24. Precision and Bias

NOTE 11—Equipment available from ISL, BP 40, 14790 VERNON - France was used to develop the precision statement for Procedure B.⁴

24.1 To estimate the precision of Procedure B, the test results from the interlaboratory study were analyzed following Practice D 6300.

24.2 The interlaboratory study included eight oils, two base oils, and six finished oils, tested in twelve laboratories.

24.3 The precision of this test method, as determined by the statistical examination of the interlaboratory study test results, is as follows:

24.3.1 *Repeatability*— The difference between two tests results obtained by same operator with the same apparatus under constant operating conditions on identical test materials would, in the long run, exceed the following value in only one case in twenty.

$$\text{Repeatability} = 0.095X^{0.5} \quad (10)$$

where

X = average of the two determinations under consideration.

24.3.2 *Reproducibility*— The difference between two single and independent results obtained by different operators working in different laboratories on identical test materials would, in the long run, exceed the following value in only one case in twenty.

$$\text{Reproducibility} = 0.26X^{0.5} \quad (11)$$

where

X = average of the two determinations under consideration.

24.4 *Bias*—Since there is no accepted reference suitable for determining the bias for this procedure, no statement on bias is being made.

Procedure C Selby-Noack Volatility Test

25. Apparatus⁶

25.1 Selby-Noack Instrument, (see Fig. 13) including glassware and other parts as follows:

25.1.1 Reaction Flask Bottom, capable of heating a sample quickly to test temperatures of 250°C.

25.1.2 Reaction Flask Top.

25.1.3 Coalescing Filter.

25.1.4 Pump Filter.

25.1.5 Orifice Tube.

25.1.6 Orifice Cap, of a set of incremental sizes.

25.1.7 Thermocouple Sheath.

25.1.8 Magnetic Stir Bar.

25.1.9 Thermocouple.

25.1.10 Measuring Rod, of known length.

25.1.11 Viton O-rings.

25.1.12 Coalescing Filter Cartridges.

25.1.13 Pump Filter Cartridges.

25.2 Balance, capable of weighing at least 300 g to the nearest 0.01 g.

25.3 Beaker, 600 mL.

25.4 Cork Ring, capable of supporting collection flask during weighing.

25.5 Digital Timer.

25.6 Tapered Glass Adapter.

⁶ The sole source of supply of the apparatus known to the committee at this time is Tannas Co., 4800 James Savage Rd., Midland, MI 48642. If you are aware of alternative suppliers, please provide this information to ASTM International Headquarters. Your comments will receive careful consideration at a meeting of the responsible technical committee¹, which you may attend.

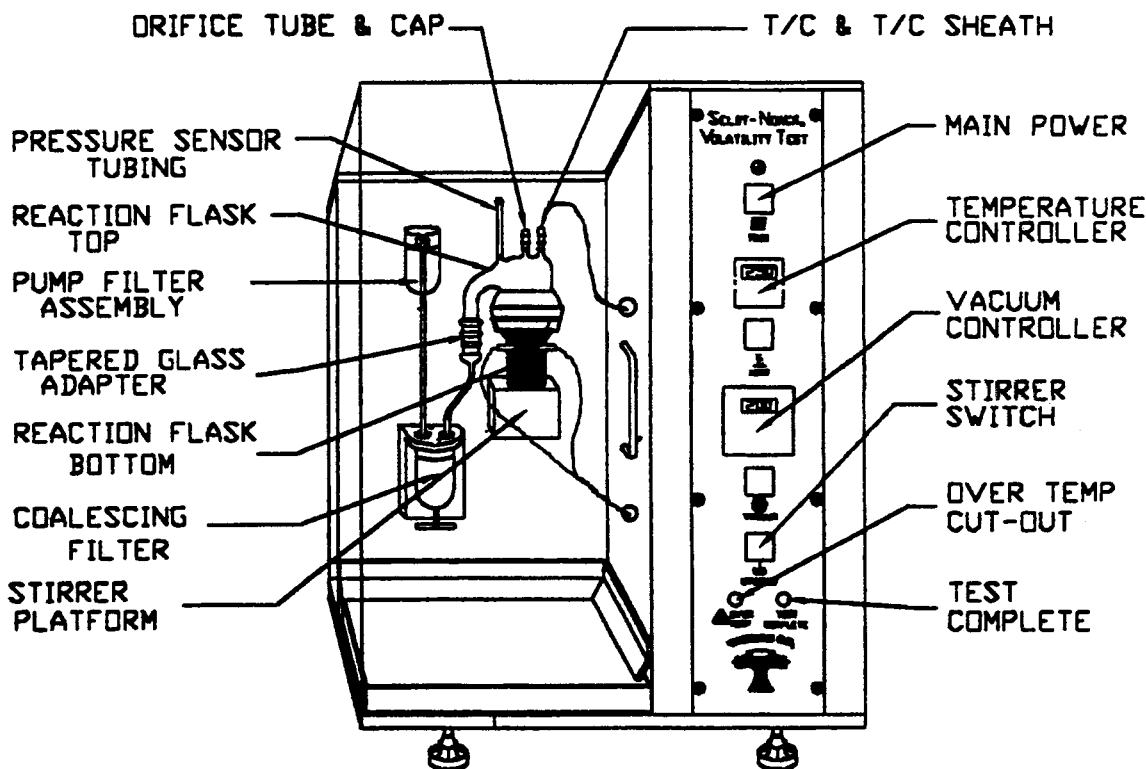

FIG. 13 Selby-Noack Test Equipment

26. Reagents and Materials

- 26.1 Cleaning Solvent, such as VarClean, capable of removing varnish from glassware
- 26.2 Hydrocarbon Solvent, such as hexane.
- 26.3 Average Volatility Reference Oil.
- 26.4 High Volatility Reference Oil.
- 26.5 Pump Oil, suitable for vacuum pump installed in instrument.

27. Preparation of Apparatus

- 27.1 Locate the instrument where there is minimal pressure fluctuation or draft. Vent the vacuum pump outlet to a suitable exhaust.
- 27.2 Set the height of the outlet of the orifice tube 11.4 cm above the inside bottom of the reaction flask.
 - 27.2.1 Measure the length of the measuring rod and the length of the orifice tube (without the cap) in centimetres.
 - 27.2.2 Add the measured length of the orifice tube without the orifice cap to 11.4 cm.
 - 27.2.3 Use the value obtained in 27.2.2 to set the length of the measuring rod by affixing the collar at that height. This will give the desired value from the lower tip of the measuring rod up to the bottom of the collar.
 - 27.2.4 Turn the tapered plastic piece on the orifice tube toward the top of threaded section and be sure the orifice cap is removed.
 - 27.2.5 Temporarily assemble the top and bottom pieces of the reactor and put the orifice tube in position.
 - 27.2.6 Insert the measuring rod through the orifice tube. When the lower end of the rod is in contact with the reactor bottom, the lower surface of the collar should be above the upper end of the orifice tube.
 - 27.2.7 Adjust the tapered plastic piece on the orifice tube down to achieve very light contact between the upper end of the orifice tube and the lower surface of the collar on the measuring rod to establish the proper position.
- 27.3 Insert the two thermocouple connectors into the thermocouple receptacles on the cabinet.
- 27.4 Insert the heater cable into the heater connection on the cabinet.
- 27.5 Be sure that the inside of the reactor bottom is clean (see 30.5) and that the other glassware, hardware, and tubing are free of any oil residue.
- 27.6 If collection of the volatilized oil is desired, clean the coalescing filter housing with a hydrocarbon solvent, dry, and install new filter cartridge.
- 27.7 Turn on the main power switch located on the front panel.
- 27.8 Before operating the instrument close the shield door.

28. Calibration

- 28.1 Calibrate the thermocouple at 100°C or higher against a certified thermometer or other standard temperature measuring

device and, if necessary, adjust the calibration offset on the temperature controller according to the manufacturer's instructions.

28.2 Preheat reaction flask bottom by placing the clean flask (with magnetic stirrer inside) on the reaction flask platform. Place the thermocouple inside the flask and be sure that the tip is firmly touching the inside wall. Set the temperature controller for 100°C and turn on the heater switch. When the temperature reaches 100°C, start the timer for 5 min.

28.3 After the 5 min has expired, turn off the heater switch and wait for the flask to cool below 50°C. After cooling, check the dry weight of the reaction flask bottom against the weight of previous weighings.

NOTE 12—The sequential weighings should be reasonably constant (that is, within ± 0.02 g) although the weight will decrease in a regular way over days and months of use. Any sudden increase in weight or erratic fluctuation is an indication that the outside insulating coating of the bottom reaction flask has been contaminated and the flask should be repeatedly baked according to 28.2 until constant weight is reestablished.

28.4 Weigh the flask with the stirring bar and record the value to the nearest 0.01 g.

28.5 Pour $65 \text{ g} \pm 0.02 \text{ g}$ of reference oil into the reaction flask. Record the mass of the oil to the nearest 0.01 g.

28.6 Insert the appropriate orifice cap size into orifice tube making certain there is a good seal. Insert the orifice tube (with the orifice cap) into the center glass tapered joint on the reaction flask top and make certain it has seated properly.

28.7 Insert the thermocouple sheath, without the thermocouple, into the thermocouple connection on the reaction flask top with the bend facing away from the glass sidearm.

28.8 Join the reaction flask top and bottom and insert the assembly into the flask clip provided.

28.9 Raise the stirrer platform to stabilize the reaction flask bottom.

28.10 If collection of volatiles is desired, weigh the clean coalescing filter assembly including the filter cartridge and record the results to the nearest 0.01 g.

28.11 Mount to bracket with the arrow pointing in the direction of air flow (toward the vacuum pump).

28.12 Connect the inlet coalescer tubing to the barbed end of the tapered glass adapter (which will be later connected to the reaction flask top sidearm).

28.13 Connect the tubing to the input side of the coalescing filter and connect the tapered glass adapter to the reaction flask top sidearm and secure with a glass joint clamp.

28.14 Connect the vacuum hose from the pump filter (above the coalescing filter) to the output connection on the coalescing filter.

28.15 Connect the hose from the pressure sensor to the barbed connection on the reaction flask top next to the sidearm. After connections are made, check that the reaction flask top is horizontal with the reaction flask bottom and that the O-ring seal between them is in proper position.

28.16 Slide the thermocouple into the thermocouple sheath in such a manner that the plastic tubing seals the joint between the thermocouple and the thermocouple sheath. This will ensure no leaks.

28.17 Make certain that the thermocouple contacts the wall. This can be viewed by looking down through the top of the reaction flask top. It is important that the thermocouple touches the inside wall of the reaction flask at least 0.5 in below the surface of the oil for proper results.

28.18 With the vacuum control Open/Close switch set to the middle or Flow position, turn on the Vacuum On/Off switch on the upper console.

28.19 Press down the Gauge Factor/Flow/Set Pt. switch and, using the Set Point dial, adjust the vacuum to 2.00 cm (20 mm) of water on the meter readout. When at a reading of 2.00, release the Gauge Factor/Flow/Set Pt. switch.

28.20 Press one finger tightly over the hole in the orifice cap and toggle the vacuum control Open/Close switch to the closed position. The vacuum reading should increase to a stable value (this must be below 19.00 cm of water). Once stabilized and with finger still in place, turn the vacuum pump off and monitor the vacuum to observe how well it maintains the vacuum. Remove finger from the orifice cap and again monitor the vacuum; it should quickly decrease to a zero reading.

28.21 If there is a leak, recheck all of the glass fittings, the orifice tube and the thermocouple sheath for proper seating. Repeat step 28.20. If there is no leak then continue to 28.22.

NOTE 13—High temperature vacuum grease may be used to seal leaks, if necessary. Vacuum grease should not be used on components that are weighed during the test procedure.

28.22 With the vacuum switch already on and controlling at 2.00 cm of water, turn on the stirrer. Visually verify the stirring.

28.23 Set the temperature controller to 250°C and turn on the heater switch. An automatic timer will activate when the heater switch is turned on. The timer will turn off the heater, vacuum, and stirring motor after 1 h.

28.24 Allow the unit to cool down to a temperature safe for handling (approximately 20 min). Gloves may be used to handle while hot.

28.25 Weigh the volatilized oil (if desired).

28.25.1 Remove the tubing from the coalescing filter assembly and remove the assembly from the bracket.

28.25.2 Weigh the entire coalescing filter assembly and record the results to the nearest 0.01 g. Subtract previous dry assembly weight from 28.10 to obtain the weight of volatilized oil.

28.25.3 Save the volatilized oil, if desired, by draining out through the petcock in the bottom of the coalescing filter housing.

28.26 Remove the pressure sensor tube and the thermocouple, and then remove the reaction flask top. The orifice tube and thermocouple sheath may be left in position during cleaning and reassembly. (If any oil is clinging to the sheath tip, touch it to

the side wall of the reactor bottom to return it to the reaction flask.)

28.27 Weigh and record the reaction flask bottom plus remaining residual oil to the nearest 0.01 g and either discard or save the residual oil for further analysis.

28.28 Clean all glassware and hardware as described in 30.1-30.7.

28.29 Calculate the percent volatility loss of the reference fluid to the nearest 0.1 % (see Section 31).

28.30 Compare the result to the given value of the reference fluid. If results are within limits, proceed to the Sample Procedure.

28.31 If the result is not within the limits of the reference fluid check that the procedure has been followed and that the apparatus is set up properly with no leaks. Check the calibration of the temperature controller and pressure sensing device.

NOTE 14—Procedures for calibration of the temperature controller and pressure controller can be found in the Operations Manual for the Selby-Noack Volatility test.

28.32 If no errors in setup or procedure are identified, proceed to changing the size of the orifice cap. The size should be changed in increments of 0.001, with each change corresponding to a directly related change of 0.3 % evaporation loss. The orifice chosen should be of the smallest size giving accurate results. Rerun the test on the reference fluid after making any changes.

NOTE 15—If using new glassware, or approximate orifice size is unknown, begin with an 0.084 orifice and increase until good results are achieved.

28.33 If problems persist, contact the instrument manufacturer.

29. Sample Procedure

29.1 Perform steps 28.4-28.28 substituting a test sample for the reference fluid.

29.2 Calculate the percent evaporation loss of the test sample to the nearest 0.1 %.

29.3 Collect the volatilized oil (if desired for further analysis) from the coalescing filter by placing a small container under the filter petcock and opening it to release the oil.

NOTE 16—It is recommended that a reference fluid be tested to confirm calibration at the beginning of each series of sample tests and at the beginning of every other day of continuous testing. If testing is not conducted on a daily basis, test the reference fluid at the beginning of each test day. If the percent evaporation loss of the reference fluid is not within limits, check the instrument for operating precision or re-calibrate before samples are tested, or both.

30. Cleaning

30.1 Clean all of the glassware and hardware, with the exception of the reaction flask bottom, with a suitable hydrocarbon solvent (for example, hexane, heptane, cyclo-hexane).

30.2 If the coalescing filter is to be used for collecting volatilized oil, it can be cleaned while disassembled. Unscrew the collection cup, remove the filter cartridge, and clean with a suitable hydrocarbon solvent (for example, hexane, heptane, cyclo-hexane). Upon reassembly, the filter cartridge can be replaced with a new, clean cartridge. The filter can also be removed from the bracket, if necessary, for cleaning.

30.3 In order to prevent oil from coming into contact with the outside of the reaction flask bottom, wrap the outside lip of the reaction flask bottom with clean toweling and quickly pour out the contents into a beaker in order to catch the stirrer bar. While still holding the flask upside down remove the towel, wipe the lip dry, and then carefully rinse the inside of the flask with a hydrocarbon solvent. When the unit is clean, wipe it dry with another towel.

NOTE 17—If the insulating covering of the reaction flask bottom becomes contaminated, follow the directions in Note 12.

30.4 If oil is spilled on the outside insulation of the reaction flask bottom, immediately rinse the oil off with a suitable hydrocarbon solvent. Exercise care not to spread the oil to other areas of the insulation. When all oil has been removed, dry the reaction flask bottom with an air source. The flask should be allowed to completely dry at room temperature before continuing with the test procedure.

30.5 Place 10 mL of a varnish removing solvent into the reaction flask bottom. Insert clean paper towel into the solvent and wipe inside of flask thoroughly, removing any varnish that may be present on the wall. Rinse carefully with hot water and dry.

30.6 If other glass parts develop a varnish film, clean these with the same procedure as indicated in 30.5 or put the parts into a half/half water or full-strength solution of varnish remover overnight.

30.7 With a towel dampened with varnish removing solvent, clean the end of the thermocouple. Wipe with towel dampened with hot water and dry to remove any remaining cleaning solvent.

31. Calculation

31.1 Percent volatility is determined by mass loss found by subtracting the combined weight of the flask bottom and oil after testing (see 28.27) from their combined weight before the test (see 28.4 and 28.5).

NOTE 18—The percent volatility is obtained by taking the mass loss of the reaction flask and dividing that by the exact mass of the test oil sample recorded earlier: that is if weight of the oil sample is 65.1 g and weight of the oil lost is 10.2 g, then $(10.2 \text{ g}/65.1 \text{ g}) \times 100 = 15.67 \%$.

31.2 The mass of volatiles collected is obtained by subtracting the coalescing filter assembly weight before the test (see 28.10) from its weight at the end of the test (see 28.26).

NOTE 19—The percent of volatiles collected is obtained by dividing the mass of volatiles collected by the mass loss: that is, If the weight of the empty

coalescing filter assembly is 163.2 g and the weight of the filter assembly after volatilization gained 9.8 g, and if the weight loss shown by 31.1 is 10.2 g, then $(9.8 \text{ g}/10.2 \text{ g}) \times 100 = 96.08 \%$ of the volatiles were collected.

32. Report

32.1 Report the evaporation loss to the nearest 0.1 %.

32.2 Limited amount of data available shows that Procedures A and C give similar results for formulated engine oils. However, no comparative data is available for the basestocks. Further work is necessary to quantitate the relationship.

33. Precision

NOTE 20—The equipment listed in the research report,⁴ was used to develop this precision statement. This is not an endorsement or certification by ASTM International.

33.1 The interlaboratory study included six test oils tested on eight apparatus with eight different operators. The samples measured in the study were engine oils covering the range of 11.84 % loss to 20.18 % loss.

33.2 *Repeatability*— The difference between successive results obtained by the same operator with the same apparatus under constant operating conditions on identical test materials would, in the long run, in the normal and correct operation of the test method, exceed the following value in only one case in twenty:

$$\text{Repeatability, \% evaporation loss} = 0.81 \quad (12)$$

33.3 *Reproducibility*— The difference between two single and independent results obtained by different operators working in different laboratories on identical test materials would, in the long run, in the normal and correct operation of the test method, exceed the following value in only one case in twenty:

$$\text{Reproducibility, \% evaporation loss} = 1.62 \quad (13)$$

34. Quality Control for Procedures A, B, and C

34.1 Procedures A, B₂ and C require confirmation of the performance of the apparatus by analyzing a quality control (QC) sample.

34.2 Prior to monitoring the measurement process, the user of the test method needs to determine the average value and control limits of the QC sample. (See Practice D 6299 and MNL 7.⁷)

34.3 Record the QC results and analyze by control charts or other statistically equivalent techniques to ascertain the statistical control status of the total testing process. (See Practice D 6299 and MNL 7.⁷) Any out-of-control data should trigger investigation for root cause(s). The results of this investigation may, but not necessarily, result in instrument recalibration.

34.4 The frequency of QC testing is dependent on the demonstrated stability of the testing process, customer requirements and the recommendations of the equipment manufacturer. The QC sample precision should be periodically checked against the ASTM test method precision to ensure data quality.

34.5 It is recommended that, if possible, the type of QC sample that is regularly tested be representative of the samples routinely analyzed. An ample supply of QC sample material should be available for the intended period of use and must be homogeneous and stable under the anticipated storage conditions.

35. Keywords

35.1 evaporation loss of lubricants; Noack volatility; volatility of lubricants

⁷ ASTM MNL7, *Manual on Presentation of Data Control Chart Analysis*, 6th ed., Section 3, Control Chart for Individuals, ASTM International, W. Conshohocken, PA 19428.

APPENDIXES
(Nonmandatory Information)
X1. HELPFUL HINTS FOR NOACK VOLATILITY (PROCEDURES A and B)

X1.1 Be sure to use the correct manometer fluid to fill the manometer. The density of the fluid is critical and must be of the type designed for the manometer (see 6.11, Note 1). Millimetres of water (implicitly at 1 G) is a unit of pressure. Not every manometer that gives readings in millimetres of water is made for use with water as the manometer fluid. Consult the manual or manufacturer for the correct manometer fluid properties.

X1.2 Be sure that the manometer reservoir is filled so that the manometer is reading exactly zero with no external vacuum or pressure. This should be checked before each run. Evaporation may require occasional refilling of the manometer reservoir. It is also important that the unit be properly leveled.

X1.3 For inclined manometers, be sure to read the meniscus at the same position at both 1 and 20 mm of water.

X1.4 Rubber tubes used for connections should be changed periodically because oil-mist causes rubber swelling after extended period of service.

X1.25 Cleaning at regular intervals of foreign material adhering on exhaust system parts, particularly on Y-glass piece, is necessary.

X1.36 There is a drop in metal bath temperature when inserting the sample. Monitor that the temperature recovers in approximately 3 min.

X1.47 Strong air drafts or turbulence around the pressure transducer or the heated crucible may adversely affect the test precision and accuracy. Do not place the apparatus in a draft area; however, the exhaust fumes from the evaporating oil shall be ventilated to an outside source.

X1.58 Clean the crucible and the cover thoroughly with solvent between tests and allow to dry. Remove stubborn lacquer by immersing in hot detergent solution, by light abrasion with fine carborundum powder, or a fine abrasive pad.

X1.69 Vacuum must be accurately set and maintained or the Noack values can be greatly altered. Run the pump for 30 min before testing. Vacuum pump should be cleaned out daily using a hydrocarbon solvent (consult manufacturer for a compatible solvent recommendation). Run a pressure test daily; let the vacuum run until the pressure stabilizes.

X1.710 Condensed liquid collecting in tubes and at junctions is also a common source of problem.

X1.811 The CEC Reference Oil, RL-172, should be analyzed each day the samples are analyzed. Make sure the correct reference oil performance certificate is being used. Some suppliers may not be correctly updating their reference oil performance certificates. Note that the evaporation loss values differ for Procedures A and B.

X1.912 Cleanliness of the extraction tube, glass and silicone tubing, and air jets should be assured prior to all tests.

X1.103 Possible contamination of the thermal sensor well with slag and Woods metal should be monitored. Slag should be checked and removed periodically after a series of runs.

X1.114 Check all connections to be sure they are tight before test. Alignment of all connections without any restrictions should be maintained. All tubing should allow all flow to travel downhill to the vacuum pump (no low points).

X1.125 Verify that the temperature probe holder spring is working properly to seat the probe correctly. The temperature probe should be cleaned to remove varnish.

X1.16 On automatic machines, if pressure reads different from zero before testing, recalibrate the pressure.

X1.137 If extraction tube is loose, tighten or check the gasket.

X1.148 Woods metal bath must be full and overflowing around crucible and thermal sensor wells.

X1.159 At all times while handling the sample crucible, be careful not to splash the test sample on the crucible lid, especially when removing the lid. Use of a table-mounted holder to hold the crucible may help prevent splashing while operating the crucible (see 20.10).

X1.19.1 Do not overtighten the crucible lid, and do not use the extraction tube as a handle to tighten or open the lid.

X1.20 *Timing*—Place the crucible in the bath, connect the vacuum and start timer in quick succession, as nearly simultaneously as possible.

X1.216 Start the pump before starting the stopwatch for the test. Instrument electronics must be on for at least 30 min prior to the start of the first test to warm up the vacuum transducer. Leaving the electronics on overnight satisfies this recommendation.

X1.4722 Monitor calibration thermometer versus recorded temperature occasionally during run. The temperature circuit electronics should be verified at least monthly using a calibrated temperature probe simulator.

X1.4823 *End of Test*—Disconnect vacuum at the end of the test time and place the crucible in cooling bath within 1 min.

~~X1.19~~

X1.24 Be careful not to tilt the crucible in handling during the test, particularly at the end.

X1.205 Final weighing should not be done until the crucible is at room temperature. Do not use extra force (for example, hammers) to open or close the crucible.

X1.246 At the end of the test, check the pressure and temperature scans from automatic machines to see that proper parameters were maintained during the runs.

X2. HELPFUL HINTS FOR SELBY-NOACK VOLATILITY (PROCEDURE C)

X2.1 Be sure that the thermocouple is touching the side of the reaction flask bottom. This can be accomplished by looking down through the reaction flask top when positioning the thermocouple.

X2.2 To reduce potential flow problems, make certain that the hose from the unit to the exhaust hood or vent is not pinched anywhere.

X2.3 To prevent leaks, securely seat all glassware, the thermocouple sheath, and the orifice tube.

X2.4 For accurate results, make certain that the test runs as close to 1 h as possible (within 15 s).

X2.5 At the end of the test, the glassware may be removed for the 20-min cool-down period using thermal gloves. This permits immediate starting of another run with a second set of glassware.

X2.6 Alternatively, two sets of top and bottom flasks may be used each with its own orifice tube and cap.

SUMMARY OF CHANGES

Subcommittee D02.06 has identified the location of selected changes to this standard since the last issue (D 5800—03a) that may impact the use of this standard. (Approved May 1, 2004.)

(1) Updated Appendix X1.

Subcommittee D02.06 has identified the location of selected changes to this standard since the last issue (D 5800–03) that may impact the use of this standard. (Approved Dec. 10, 2003.)

- (1) Revised Section 1 to mention differences in the results obtained by Procedures A and B.
- (2) Added 22.2 to provide correlation equations between results by Procedures A and B.
- (3) Updated Section 23 to include new reporting protocols.
- (4) Added 32.2 to discuss the results obtained by Procedures A and C.

ASTM International takes no position respecting the validity of any patent rights asserted in connection with any item mentioned in this standard. Users of this standard are expressly advised that determination of the validity of any such patent rights, and the risk of infringement of such rights, are entirely their own responsibility.

This standard is subject to revision at any time by the responsible technical committee and must be reviewed every five years and if not revised, either reapproved or withdrawn. Your comments are invited either for revision of this standard or for additional standards and should be addressed to ASTM International Headquarters. Your comments will receive careful consideration at a meeting of the responsible technical committee, which you may attend. If you feel that your comments have not received a fair hearing you should make your views known to the ASTM Committee on Standards, at the address shown below.

This standard is copyrighted by ASTM International, 100 Barr Harbor Drive, PO Box C700, West Conshohocken, PA 19428-2959, United States. Individual reprints (single or multiple copies) of this standard may be obtained by contacting ASTM at the above address or at 610-832-9585 (phone), 610-832-9555 (fax), or service@astm.org (e-mail); or through the ASTM website (www.astm.org).