



Standard Test Method for Evaluation of Automotive Engine Oils in the Sequence VIII Spark-Ignition Engine (CLR Oil Test Engine)¹

This standard is issued under the fixed designation D 6709; the number immediately following the designation indicates the year of original adoption or, in the case of revision, the year of last revision. A number in parentheses indicates the year of last reapproval. A superscript epsilon (ϵ) indicates an editorial change since the last revision or reapproval.

INTRODUCTION

This test method can be used by any properly equipped laboratory without outside assistance. However, the ASTM Test Monitoring Center (TMC)² offers a very valuable service to the test laboratory; the Center provides reference oils and an assessment of the test results obtained on those oils by the laboratory (see Appendix X1). By this means, the laboratory will know whether their use of the test method gives results statistically similar to those obtained by other laboratories. Furthermore, various agencies require that a laboratory utilize the TMC services in seeking qualification of oils against specifications. For example, the American Petroleum Institute (API) imposes such a requirement, in connection with several engine lubricating oil specifications.

Accordingly, this test method is written for use by laboratories that utilize the TMC services. Laboratories that choose not to use those services may simply ignore those portions of the test method that refer to the TMC.

This test method may be modified by means of Information Letters issued by the TMC. In addition, the TMC may issue supplementary memoranda related to the test method (see Annex A3).

1. Scope

1.1 This test method covers the evaluation of automotive engine oils (SAE grades 5W, 10W, 20, 30, 40, and 50, and multiviscosity grades) intended for use in spark-ignition gasoline engines. The test procedure is conducted using a carbureted, spark-ignition Cooperative Lubrication Research (CLR) Oil Test Engine (also referred to as the Sequence VIII test engine in this test method) run on unleaded fuel. An oil is evaluated for its ability to protect the engine and the oil from deterioration under high-temperature and severe service conditions. The test method can also be used to evaluate the viscosity stability of multiviscosity-graded oils. Companion test methods used to evaluate engine oil performance for specification requirements are discussed in the latest revision of Specification D 4485.

1.2 Correlation of test results with those obtained in automotive service has not been established. Furthermore, the results obtained in this test are not necessarily indicative of results that will be obtained in a full-scale automotive spark-ignition or compression-ignition engine, or in an engine operated under conditions different from those of the test. The test can be used to compare one oil with another.

1.3 The values stated in SI units are to be regarded as standard, except for (1) volume which is given in the metric, but non-SI, litre, (2) certain tube measurements which are given in inch-pound units, (3) cylinder bore and stroke in both SI and inch-pound units (the inch-pound being the standard) and (4) piston displacement given in metric (non-SI) and inch-pound units (the inch-pound being the standard). In respect to (3) and (4) the inch-pound units are shown first and the SI units in parentheses.

1.4 *This standard does not purport to address all of the safety concerns, if any, associated with its use. It is the responsibility of the user of this standard to establish appropriate safety and health practices and determine the applicability of regulatory limitations prior to use.* Specific precautionary statements are provided throughout this test method.

1.5 This test method is arranged as follows:

Subject

Section

¹ This test method is under the jurisdiction of ASTM Committee D02 on Petroleum Products and Lubricants and is the direct responsibility of Subcommittee D02.B0 on Automotive Lubricants.

Current edition approved May 10, Nov. 1, 2003. Published January 2003. Originally approved in 2001. Last previous edition approved in 2003 as D 6709-03.

² Until the next revision of this test method, the ASTM Test Monitoring Center will update changes in this test method by means of Information Letters. This edition includes all Information Letters through 02-1. Information Letters may be obtained from the ASTM Test Monitoring Center, 6555 Penn Avenue, Pittsburgh, PA 15202-4489, Attention: Administrator. This edition incorporates revisions in all Information Letters through No. 02-2.

Introduction		1
Scope		2
Referenced Documents		3
Terminology		4
Summary of Test Method		4.1
	Before Test Starts	4.2
	Power Section Installation	4.3
	Engine Operation (Break-in)	4.4
	Engine Operation (Test/Samples)	4.5
	Stripped Viscosity	4.6
	Test Completion (BWL)	5
Significance and Use		5.1
	Evaluation of Automotive oils	5.2
	Stay in Grade Capabilities	5.3
	Correlation of Results	5.4
	Use	6
Apparatus		6.1
	Test Engineering, Inc.	6.2
	Fabricated or Specially Prepared Items	6.3
	Instruments and Controls	6.4
	Procurement of Parts	7
Reagents and Materials		7.1
	Reagents	7.2
	Cleaning Materials	7.3
	Expendable Power Section-Related Items	7.4
	Power Section Coolant	7.5
	Reference Oils	7.6
	Test Fuel	8
Test Oil Sample Requirements		8.1
	Selection	8.2
	Inspection	8.3
	Quantity	9
Preparation of Apparatus		9.1
	Test Stand Preparation	9.2
	Conditioning Test Run on Power Section	9.3
	General Power Section Rebuild Instructions	9.4
	Reconditioning of Power Section After Each Test	10
Calibration		10.1
	Power Section and Test Stand Calibration	10.2
	Instrumentation Calibration	10.3
	Calibration of AFR Measurement Equipment	10.4
	Calibration of Torque Wrenches	11
Engine Operating Procedure		11.1
	Run-In and Flush	11.2
	Test Operating Conditions	11.3
	Air-Fuel Ratio and Spark Advance	11.4
	Air, Off-Gas and Blowby Measurement	11.5
	Unscheduled Shutdowns	11.6
	Oil Sampling and Oil Addition	11.7
	Periodic Measurements	11.8
	Final Oil Drain and Oil Consumption Computation	11.9
	Operational Validity Criteria	11.10
	Test Completion	12
Determination of Test Results		12.1
	Oil Analysis	12.2
	Test Bearing Weight Loss Determination	13
Report		14
Precision and Bias		14.1
	Precision	14.2
	Bias	15
Use of ASTM Rounding		16
Keywords		
ANNEXES		
Measurement of Connecting Rod Bearing Clearance and Journal Taper		Annex A1
Measurement of Main Bearing Clearance		Annex A2
The ASTM Test Monitoring Center Calibration Program		Annex A3
Measurement of Piston-to-Sleeve Clearance		Annex A4
Control Chart Technique for a Laboratory's Severity Adjustment (SA)		Annex A5
Recommended New Liner Honing Procedure		Annex A6
Sequence VIII Oil Priming Procedure		Annex A7
Alternative Crankcase Breather Configuration		Annex A8
Connecting Rod Bearing Cleaning Procedure		Annex A9
Electronic Ignition Conversion		Annex A10
System Response Procedure		Annex A11
Air-Fuel Ratio Measurement		Annex A12
Lead Decontamination Procedure		Annex A13

Stay-in-Grade Oil Analysis Procedure
Crankshaft Rear Seal Conditioning
Report Forms

Report Forms and Data Dictionary

Annex A14
Annex A15
Annex A16 Data
Dictionary
Annex A16 Data
Dictionary

APPENDIXES

Role of the ASTM Test Monitoring Center and the Calibration Program
Suggested Method for Salvaging Camshaft Bearing Journals
Data Log Sheets

Appendix X1
Appendix X2
Appendix X3

2. Referenced Documents

2.1 ASTM Standards:³

- D 235 Specification for Mineral Spirits (Petroleum Spirits) (Hydrocarbon Dry Cleaning Solvents)
- D 445 Test Method for Kinematic Viscosity of Transparent and Opaque Liquids (the Calculation of Dynamic Viscosity)
- D 2422 Classification of Industrial Fluid Lubricants by Viscosity System
- D 4485 Specification for Performance of Engine Oils
- D 5119 Test Method for Evaluation of Automotive Engine Oils in the CRC L-38 Spark-Ignition Engine
- D 5302 Test Method for Evaluation of Engine Oils for Inhibition of Deposit Formation and Wear in a Spark-Ignition Internal Combustion Engine Fueled with Gasoline and Operated under Low-Temperature, Light-Duty Conditions
- D 5533 Test Method for Evaluation of Automotive Engine Oils in the Sequence III E, Spark-Ignition Engine
- D 5844 Test Method for Evaluation of Engine Oils for Inhibition of Rusting (Sequence IID)
- D 6202 Test Method for Automotive Engine Oils on the Fuel Economy of Passenger Cars and Light-Duty Trucks in the Sequence VIA Spark-Ignition Engine
- E 29 Practice for Using Significant Digits in Test Data to Determine Conformance with Specifications

2.2 SAE Standards:⁴

- J183, Engine Oil Performance and Engine Service Classification (Other Than “Energy-Conserving”)
- J304, Engine Oil Tests

3. Terminology

3.1 Definitions:

- 3.1.1 *air-fuel ratio, n*—in internal combustion engines, the mass ratio of air-to-fuel in the mixture being induced into the combustion chambers. **D 6202**
- 3.1.2 *automotive, adj*—descriptive of equipment associated with self-propelled machinery, usually vehicles driven by internal combustion engines. **D 4485**
- 3.1.3 *blind reference oil, n*—a reference oil, the identity of which is unknown by the test facility.
 - 3.1.3.1 *Discussion*—This is a coded reference oil that is submitted by a source independent from the test facility. **D 5844**
- 3.1.4 *blowby, n*—in internal combustion engines, the combustion products and unburned air-and-fuel mixture that enter the crankcase. **D 5302**
- 3.1.5 *critical parts, n*—those components used in the test that are known to affect test severity.
- 3.1.6 *noncompounded engine oil, n*—a lubricating oil having a viscosity within the range of viscosities of oils normally used in engines, and that may contain anti-foam agents or pour depressants, or both, but not other additives. **D 5119**
 - 3.1.6.1 *Discussion*—In this test method noncompounded oil is also known as build-up oil. This discussion does not appear in Test Method D 5119.
- 3.1.7 *non-standard test, n*—a test that is not conducted in conformance with the requirements in the standard test method; such as running on an uncalibrated test stand, using different test equipment, applying different equipment assembly procedures, or using modified operating conditions. **D 5844**
- 3.1.8 *test start, n*—introduction of test oil into the engine. **D 5533**
- 3.1.9 *wear, n*—the loss or relocation of material from a surface.
 - 3.1.9.1 *Discussion*—Wear generally occurs between two surfaces moving relative to each other, and is the result of mechanical or chemical action or by a combination of mechanical and chemical actions. **D 5302**

3.2 Definitions of Terms Specific to This Standard:

- 3.2.1 *accessory case, n*—the mounting base containing the balancing mechanism, flywheel, and final driveshaft for the power section of the CLR engine.
 - 3.2.1.1 *Discussion*—This definition was modified to embrace the CLR engine. The definition in Test Method D 5119 embraces the L-38 engine.

³ For referenced ASTM standards, visit the ASTM website, www.astm.org, or contact ASTM Customer Service at service@astm.org. For Annual Book of ASTM Standards, Vol 06.04, volume information, refer to the standard's Document Summary page on the ASTM website.

⁴ Available from Society of Automotive Engineers, Inc., 400 Commonwealth Drive, Warrendale, PA 15096. Request SAE Handbook Vol-05-04. This standard is not available separately.

- 3.2.2 *build-up oil, n*—see 3.1.6, noncompounded engine oil.
- 3.2.3 *calibrated power section/test stand combination, n*—one that has completed an operationally valid reference oil test within the previous six months, the results of which fall within industry severity and precision limits as published by the TMC.
- 3.2.4 *conditioning test run, n*—a full-length Sequence VIII test using a TMC-designated reference oil in a new or newly rebuilt power section to prepare the cast iron parts before conducting routine standard tests with the power section.
- 3.2.5 *emergency shutdown, n*—the procedure for turning off the engine’s ignition without using the prescribed engine cool-down period.
- 3.2.6 *full-length test, n*—a test of an engine oil conducted using a power section and a test stand that runs 4½-h run-in, 2-h flush and 40 h at test conditions. (See 10.1.3.1, exception for 10-h stay in grade test).
- 3.2.7 *new power section, n*—an engine power section consisting of either a new crankcase or complete power section that has no previous oil test history.
- 3.2.8 *off-gas, n*—gas exiting the power section crankcase breather.
- 3.2.9 *off-test time, n*—any time that the engine is not operating at the prescribed test conditions.
- 3.2.10 *oil gallery side cover plate, n*—crankcase cover plate that contains the oil gallery and provision for mounting and driving the oil pump and ignition assembly.
- 3.2.11 *operationally valid test, n*—an engine oil test that has been conducted in accordance with the conditions listed in this test method.
- 3.2.12 *power section, n*—the combination of the crankcase assembly, the cylinder block assembly, and the cylinder head assembly, all of which are attached to the accessory case.
- 3.2.13 *reconditioned power section, n*—an engine power section which has been disassembled, cleaned, and reassembled according to the detailed procedures⁵ after completion of either a conditioning test run or a full-length CLR engine oil test.
- 3.2.14 *reference oil test, n*—a standard Sequence VIII engine oil test of a reference oil designated by the TMC, conducted to ensure that power section and test stand severity falls within industry limits.
- 3.2.15 *run-in and flush, n*—the initial 4-2-h½-h operation of a new, rebuilt, or reconditioned power section at the beginning of either a conditioning test run or a full-length test.
- 3.2.16 *scheduled downtime, n*—off-test time that is specifically allowed to include warm-up and cool-down periods as well as shutdown and intermediate bearing weight loss measurements.
- 3.2.17 *shutdown, n*—the procedure for turning off the engine’s ignition following the prescribed engine cool-down period.
- 3.2.18 *standard test, n*—an operationally valid, full-length Sequence VIII test conducted with a calibrated power section and test stand in accordance with the conditions listed in this test method.
- 3.2.19 *stay-in-grade (stripped viscosity), n*—the viscosity of the test oil after removal of volatile components and solids, according to the procedure shown in Annex A14.
- 3.2.20 *test oil, n*—an oil subjected to a Sequence VIII engine oil test.
- 3.2.20.1 *Discussion*—It can be any oil selected by the laboratory conducting the test. It could be an experimental oil or a commercially available oil. Often, it is an oil that is a candidate for approval against engine oil specifications.
- 3.2.21 *test stand, n*—the engine accessory case connected to a dynamometer, both mounted to a suitable foundation (such as a bedplate) and equipped with suitable supplies of electricity, compressed air, and so forth, to provide a means for mounting and operating a power section in order to conduct a Sequence VIII engine oil test.
- 3.3 *Acronyms:*
- 3.3.1 *BTDC, adj*—before top dead center
- 3.3.1.1 *Discussion*—It is used with the degree symbol to indicate the angular position of the crankshaft from its position at the point of uppermost travel of the piston in the cylinder.
- 3.3.2 *EWMA, n*—exponentially-weighted moving average
- 3.3.3 *LTMS, n*—Lubricant Test Monitoring System

Annual Book

⁵ Refer to Instructions for Assembly and Disassembly of ASTM Standards, Vol 05.02: the CLR Oil Test Engine, available from Test Engineering, Inc., 12718 Cimarron Path, San Antonio, TX 78249.

TABLE 1 Power Section Run-in Schedule

Speed, r/min (±25)	Load		Spark Advance, ° BTDC (±1)	Time, min (±2)	Total Time, h
	bhp (±0.2)	(w) (±150)			
1500	2.0	(1500)	25	60	1
2000	4.0	(3000)	25	60	2
2500	5.0	(3700)	35	60	3
3150	5.0	(3700)	35	60	4

3.3.3.1 *Discussion*—An analytical system in which ASTM calibration test data are used to manage lubricant engine test precision.

3.3.4 *SIG, adj*—stay-in-grade

3.3.4.1 *Discussion*—Capability of multiviscosity-graded oil to stay in grade under test conditions (see 4.5).

3.3.5 *TDC, adj*—top dead center

3.3.5.1 *Discussion*—It is used with the degree symbol to indicate the angular position of the crankshaft from its position at the point of uppermost travel of the piston in the cylinder.

4. Summary of Test Method

4.1 Before every Sequence VIII engine oil test, thoroughly clean the power section of the CLR oil test engine ~~is thoroughly cleaned, engine, and measure the power section parts are measured. A~~ parts. Install a new or clean used piston, a complete set of new piston rings, a set of new copper-lead connecting rod test bearing inserts (from a batch approved by the ASTM D02.B0.01 Sequence VIII Test Surveillance Panel), and other specified parts as ~~required are installed. required.~~

4.2 The power section is installed on an accessory case/test stand. Unleaded fuel is used for the test.

4.3 The engine is first operated for 4 h according to a ~~run-in and flush~~ run-in schedule shown in Table 1 (see 11.1).

4.4 The engine is then operated for 40 h under specified conditions (Table 2). At the end of each 10-h of test conditions, a sample of the test oil is drained from the power section and fresh oil is returned to the power section for continuation of the test.

4.5 An oil sample is taken at the end of the first 10-h of test conditions. When multiviscosity-graded oils are being tested, this sample is used to determine the stay-in-grade (SIG) capabilities of the test oil.

4.6 At the completion of the test, the connecting rod bearing weight loss is determined.

5. Significance and Use

5.1 This test method is used to evaluate automotive engine oils for protection of engines against bearing weight loss.

5.2 This test method is also used to evaluate the SIG capabilities of multiviscosity-graded oils.

5.3 Correlation of test results with those obtained in automotive service has not been established.

5.4 *Use*—The Sequence VIII test method is useful for engine oil specification acceptance. It is used in specifications and classifications of engine lubricating oils, such as the following:

5.4.1 Specification D 4485.

5.4.2 API Publication 1509 Engine Oil Licensing and Certification System.⁶

5.4.3 SAE Classification J304.

6. Apparatus

6.1 *Test Engineering, Inc.*—The document “Instructions for Assembly and Disassembly of the CLR Test Engine”⁵ provides detailed parts listings, modification instructions, assembly/disassembly instructions, maintenance procedures, and parts replacement requirements. The following is a descriptive listing of some of the test engine and associated parts.

Annual Book of ASTM Standards, Vol 05.03.

⁶ American Petroleum Institute, 1220 L Street, NW, Washington, DC 20005.

TABLE 2 Test Operating Conditions

Item	Setting
Speed, r/min	3150 ± 25
Load bhp	Adjust load to provide proper fuel flow at specified air-fuel ratio.
Fuel flow, kg/h (lb/h)	2.15 ± 0.11 (4.75 ± 0.25)
Air-fuel ratio	14.0 ± 0.5
Air-fuel ratio	13.43 ± 0.5
Jacket outlet coolant Temperature, °C (°F)	93.5 ± 1 (200 ± 2)
Difference between jacket Inlet and jacket outlet Coolant temperatures, °C (°F)	5.6 ± 1 (10 ± 2)
Gallery oil temperature, °C (°F)	
SAE 5W, 10W	135 ± 1 (275 ± 2)
SAE 20, 30, 40, 50, and multiviscosity-graded oils	143.5 ± 1 (290 ± 2)
Spark advance, °BTDC	35 ± 1
Oil pressure, kPa (psi)	276 ± 14 (40 ± 2)
Crankcase vacuum, Pa (in. H ₂ O)	500 ± 120 (2 ± 0.5)
Exhaust back pressure, Pa (in. Hg)	0 to 3.4 (0 to 1)
Crankcase off-gas, SCFH	30 ± 4
Crankcase off-gas, SLH	850 ± 28
Blowby, SCFH	record
Blowby, SLH	record

6.1.1 *Test Engine*— Obtain the test engine from Test Engineering Inc. (TEI).⁵ The test engine is known by various designations such as the L-38 engine, the CLR engine, or the Sequence VIII engine (as used in this test method). It comprises two principal units, the power section and the accessory case (Fig. 1). The power section is a single-cylinder, spark-ignition unit with 96.5-mm (3.80-in.) bore and 95.2-mm (3.75-in.) stroke, displacing 0.696 L (42.5 in.³).

6.1.2 *Test Bearing*— SAE H-24 alloy connecting rod bearing, TEI Part No. 100034-1, from a batch approved by the ASTM Sequence VIII Test Surveillance Panel.

6.1.3 *Test Engine Crankshaft*—Obtain a crankshaft for the CLR test engine, Part No. 100039-1, from TEI. If desired, the crankshaft may be refinished in one of the following two manners:

6.1.3.1 The oil seal and main bearing journals may be refinished by welding material to the journals and regrinding the journals to the original specifications. The connecting rod journal shall not be refinished using this test method.

6.1.3.2 The crankshaft may be refinished by chrome plating^{7,8} the oil seal, connecting rod journal, and main bearing journals. When refinishing a crankshaft using this test method, all journals listed shall be chrome plated.

6.1.3.3 To identify the crankshaft being used in a power section the following identification is required:

- (1) S = standard crankshaft,
- (2) C = chrome crankshaft, and
- (3) R = reconditioned crankshaft.

6.1.4 *Test Engine Piston*—Obtain a piston for the CLR test engine, TEI Part No. 2405, from TEI. If desired, a piston may be reused if it meets the piston-to-liner clearance specifications. Pistons used in the CLR test engine for L-38 testing, or any other testing using leaded fuel, shall not be reused in Sequence VIII testing. Used pistons shall be cleaned according to the following procedure before installation in the test engine.

6.1.4.1 Clean the piston crown of any carbon deposits using aliphatic naphtha and 3M fine-grade Scotch Brite pads. Wet the cleaning pad in the solvent and scrub the deposit. Repeat until all carbon is removed.

6.1.4.2 Spray piston with clean solvent and air dry.

Annual Book

⁷ The sole source of ASTM Standards, Vol 14.02, supply of crankshaft refinishing by chrome plating known to the committee at this time is OH Technologies, Inc., P.O. Box 5039, Mentor, OH, 44061-5039.

⁸ Available from Society

⁸ If you are aware of Automotive Engineers, Inc., 400 Commonwealth Drive, Warrendale, PA 15096. Request SAE Handbook Vol 3. This standard is not available separately; alternative suppliers, please provide this information to ASTM International Headquarters. Your comments will receive careful consideration at a meeting of the responsible technical committee,¹ which you may attend.

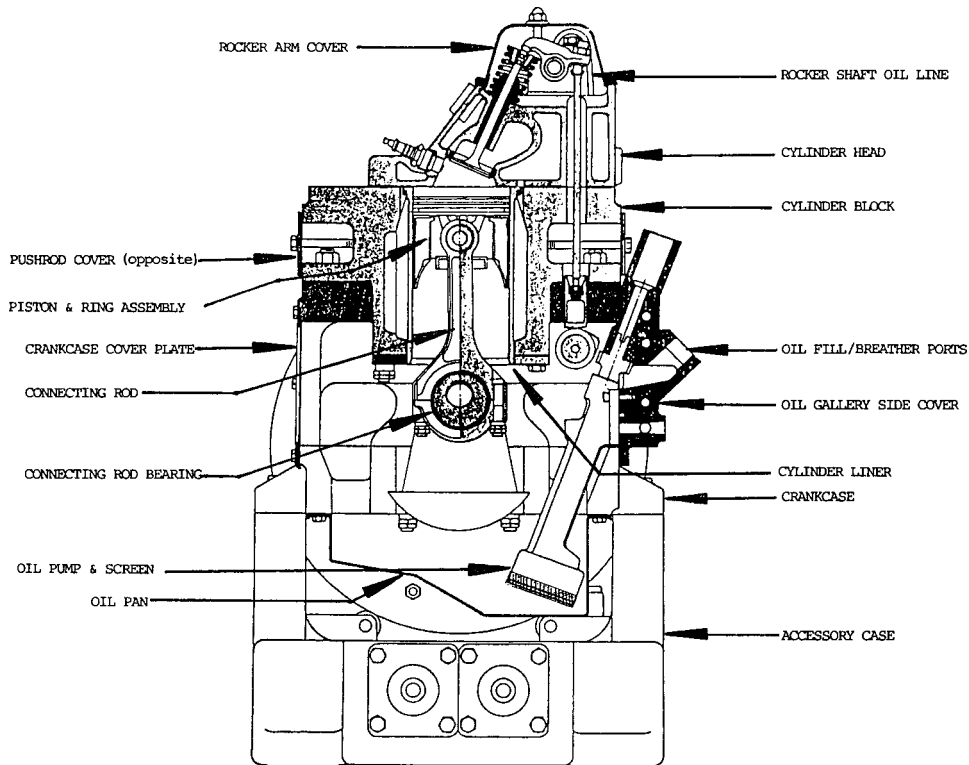

FIG. 1 Sequence VIII Power Section

6.1.5 *Piston Ring Assembly*—Use a Dana/Perfect Circle piston ring assembly, Part No. 41274, in the Sequence VIII test engine.^{8,9}

6.2 *Fabricated or Specially Prepared Items:*

6.2.1 A typical Sequence VIII engine test stand configuration is shown in Fig. 2.

6.2.2 *Crankcase Ventilation System* —Fig. 3 is a schematic of the required configuration of the crankcase ventilation measurement and control system.

6.2.2.1 Fabricate the airtight rocker cover air and off-gas condensate trap/surge tanks shown in Fig. 3, with provisions for draining and cleaning. The volume of the rocker cover air tank shall be 3.8 to 5.7 L (1 to 1.5 gal). The volume of the off-gas tank shall be 38 to 45 L (10 to 12 gal). Fabricate both tanks from noncorrosive material. Locate the tanks as shown in Fig. 3.

6.2.2.2 *Rocker Cover Air Flow*—Measure the air flow into the rocker cover by using a Sierra Side Track Model 830 flow meter^{8,10} capable of measuring 0 to 20 L/min. An optional Dwyer rotameter, Model No. RMC-101,^{8,11} with a range of 0 to 1420 L/h may be used for ease of adjustments; however, actual measurements shall be taken with the Sierra flow meter. All piping and tubing used to flow air into the rocker cover shall be nominal 3/8-in. I.D.

6.2.2.3 When a closed loop automated control system is employed, use a Badger meter research control valve, Model No. 1002-GCN36-SVCSC-LN36,^{8,12} (see Note 1) to control the rocker cover air flow. When using a manual control system instead of the automated system, install a Swagelok 3/8-in. metering valve, Part No. SS-6L¹³, to control the air flow into the rocker cover.

NOTE 1—The letter prior to the last dash in the model number defines the trim size. Use the trim that gives the best system control.

6.2.2.4 Fig. 4 shows the details of the rocker cover inlet for the crankcase ventilation air. Braze one half of a 1/8-in. (3.2-mm) connector with the beveled end facing the near corner of the rocker cover. Tighten the connector nut securely.

6.2.2.5 Construct the off-gas breather¹³ as shown in Fig. 5 using American Standard Schedule 40, or equivalent, non-galvanized pipe fittings. Apply sealant to the threads during assembly. Install the breather in the breather port of the oil gallery side cover (see Fig. 6) of the engine power section. Fig. A8.1 shows freeze plug detail in an alternative configuration to that in Fig. 5.

6.2.2.6 *Crankcase Off-Gas Flow* —Measure the crankcase off-gas flow by using a Daniels Honed Orifice Flange Flow Section,

⁹ Refer to Instructions for Assembly and Disassembly

⁹ The sole source of supply of the CLR Oil Test Engine, available from Test Engineering, Inc., 12718 Cimarron Path, San Antonio, TX 78249; Dana/Perfect Circle piston ring assembly Part No. 41274 known to the committee at this time is Dana Corp., Perfect Circle Division, 1883 E. Laketon Ave., Product Distribution Center, Muskegon, MI 49442-6123.

¹⁰ American Petroleum Institute, 1220 L Street, NW, Washington, DC 20005.

¹⁰ The sole source of supply of Sierra Side Track flow meters known to the committee at this time is Sierra Instruments Inc., 5 Harris Ct, Building L, Monterey, CA 93940.

¹¹ The sole source of supply of crankshaft refinishing by chrome plating Dwyer instrumentation known to the committee at this time is OH Technologies, Dwyer Instruments Inc., P.O. Box 5039, Mentor, OH, 44061-5039; 60725, Houston, TX 77205.

¹² If you are aware

¹² The sole source of alternative suppliers, please provide this information to ASTM International Headquarters. Your comments will receive careful consideration at a meeting supply of Badger valves known to the responsible technical committee, which you may attend; committee at this time is Badger Meter Industrial Div., 6116 East 15th St., P.O. Box 581390, Tulsa, OK 74158-1390.

¹³ Except for the stainless steel wool and screens, parts for the construction of supply of the Dana/Perfect Circle piston ring assembly Part No. 41274 known to crankcase breather may be obtained from many commercial sources. The part numbers given identify the committee at this time is Dana Corp., Perfect Circle Division, 1883 E. Laketon Ave., Product Distribution Center, Muskegon, MI 49442-6123; components available from McMaster Carr, Chicago, IL.

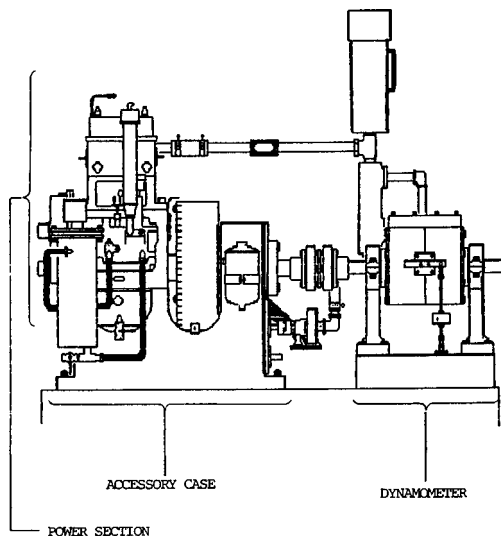

FIG. 2 Typical Sequence VIII Engine Test Stand

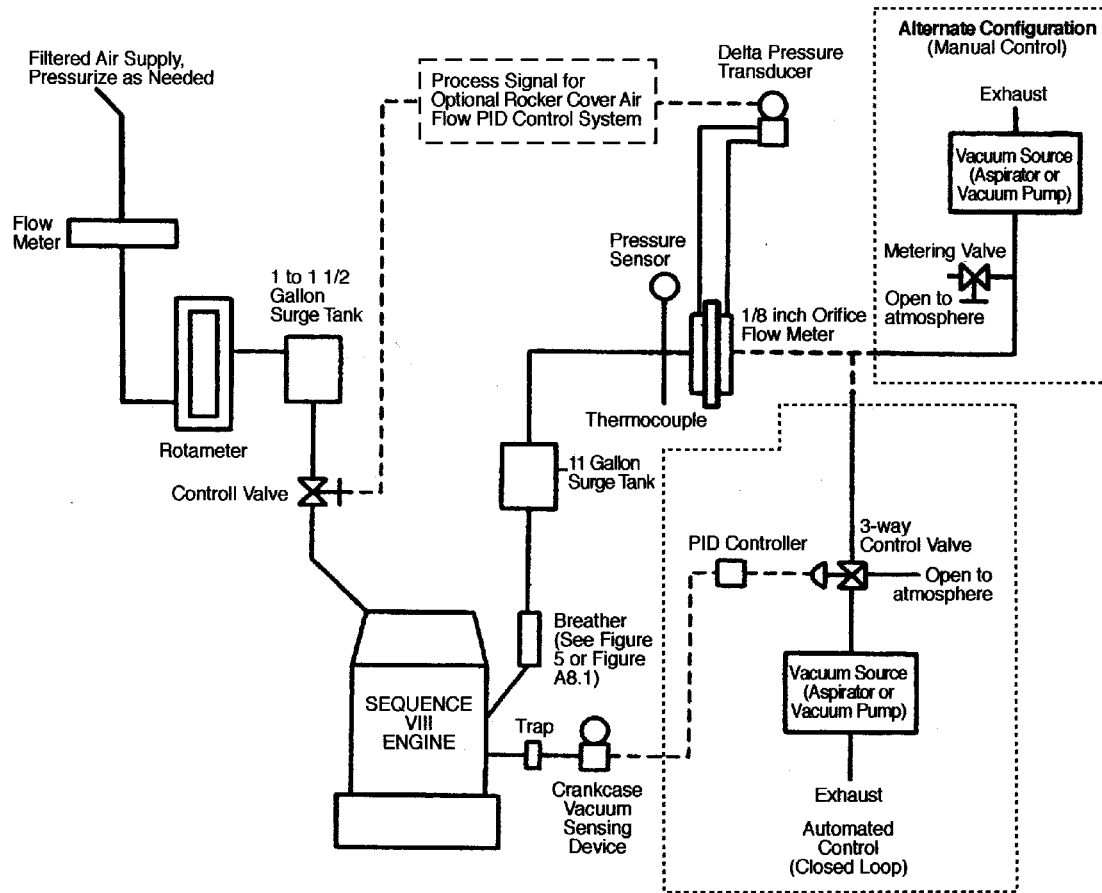

FIG. 3 Standard Crankcase Ventilation System for the Sequence VIII Power Section

Model No. H1905T-1/2 in.,^{8,14} with orifice plate, F-150-1/8 in., and a Rosemount differential pressure transducer, Model No. 1151DP-3-S-22-D1B2.^{8,15} Mount the flow section horizontally. The transducer may be set up as square root extracting to aid in interfacing with the readout. Locate temperature and pressure measurement devices at the inlet of the off-gas measurement apparatus as shown in Fig. 3.

6.2.2.7 When a closed loop automated control system is employed, use a Badger meter research control valve, Model No. 1002-TCN36-SVCSA-LN36, to control the crankcase vacuum. When using a manual control system instead of the automated control system, install a Swagelok 3/8-in. metering valve, Part No. SS-6L, to control the crankcase vacuum. Both systems are shown in Fig. 3.

6.2.2.8 Use a Vaccom vacuum aspirator, Model No. JD-90M,^{8,16} or a vacuum pump as a vacuum source.

6.2.2.9 *Rocker Cover Air Inlet Pressure* —Use a Dwyer Magnehelic, Model No. 2320, or a Sensotech pressure transducer, Model No. TJE-756-05,^{8,17} to measure the rocker cover air pressure. Convert the measured value to kPa for use in off-gas measurement calculation (see 11.4.1) Locate the sensor at the inlet of the rocker cover air flow apparatus as shown in Fig. 3.

6.2.2.10 *Crankcase Off-Gas Inlet Pressure*—Use a Dwyer Magnehelic, Model No. 2320, or a Sensotech pressure transducer, Model No. TJE-756-05, to measure the off-gas air pressure. Locate the sensor at the inlet of the off-gas air flow apparatus as shown in Fig. 3.

6.2.2.11 *Rocker Cover Air Inlet Temperature* —Measure the rocker cover inlet air temperature with a 1/8-in. J-type thermocouple. Position the thermocouple tip in the middle of the air stream and expose no more than 50 mm of the sheath to

¹⁴ The sole source of supply of Sierra Side Track Daniels flow meters sections known to the committee at this time is Sierra Instruments Daniel Flow Products Inc., 5 Harris Ct, Building L, Monterey, CA 93940; Flow Measurement Products Div., P.O. Box 19097, Houston, TX 77224.

¹⁵ The sole source of supply of Dwyer instrumentation Rosemount transducers known to the committee at this time is Dwyer Instruments Rosemount Inc., P.O. Box 60725, Houston, 4001 Greenbriar, Ste 150B, Stafford, TX 77205-7747.

¹⁶ The sole source of supply of Badger valves Vaccom aspirators known to the committee at this time is Badger Meter Industrial Div., 6116 East 15th St., P.O. Box 581390, Tulsa, OK 74158-1390; McKenzie Air Industries, 18523 IH 35 North, Shertz, TX 78108.

¹⁷ Except for the stainless steel wool and screens, parts for the construction

¹⁷ The sole source of supply of Sensotec transducers known to the crankcase breather may be obtained from many commercial sources. The part numbers given identify the components available from McMaster-Carr, Chicago, IL; committee at this time is Sensotec Inc., 1200 Chesapeake Ave., Columbus, OH 43212.

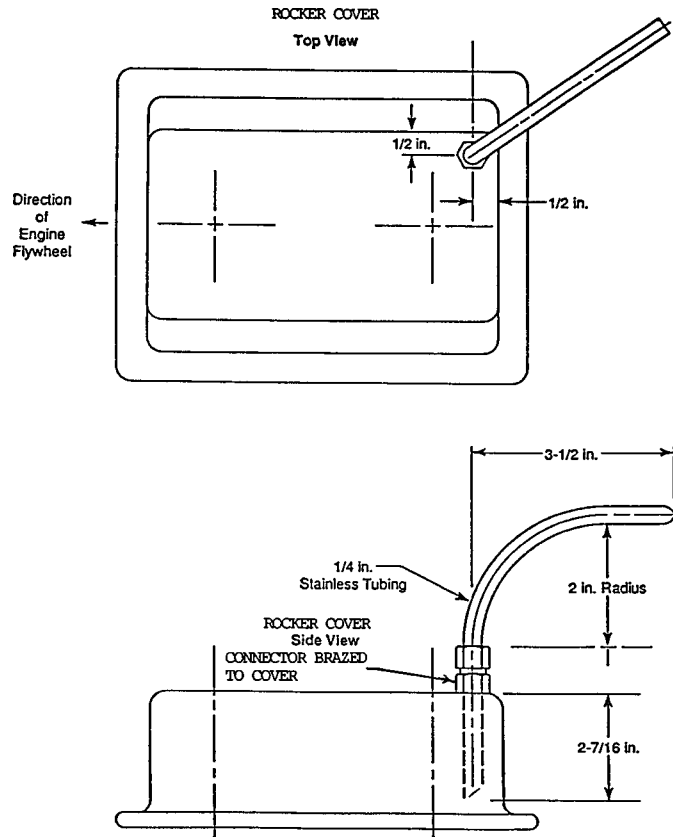

Metric Equivalents

in.	mm
1/4	6.4
1/2	13
2	51
27/16	62
3 1/2	89

FIG. 4 Rocker Cover Air Inlet Detail

ambient air. Locate the thermocouple at the inlet of the rocker cover air measurement apparatus as shown in Fig. 3.

6.2.2.12 *Crankcase Off-Gas Inlet Temperature*—Measure the off-gas temperature with a 1/8-in. J-type thermocouple. Position the thermocouple tip in the middle of the air stream and expose no more than 50 mm of the sheath to ambient air. Locate the thermocouple at the inlet of the off-gas flow measurement apparatus as shown in Fig. 3.

6.2.3 *Oil Filter*—Install a Racor, Model LFS-62,^{8,18} the specified oil filter as shown in Fig. 7. Use suitable hydraulic hose and fittings.¹⁹

6.2.3.1 *Oil Drain Valves*—Locate oil drain valves at points no higher than the bottom of the oil pan or the vertically mounted oil heater.

6.2.4 *Oil Heater*—Install the oil heater as shown in Fig. 8. Use suitable hydraulic hose and fittings.¹⁹

6.2.5 *Power Section Cooling System*—Install a non-pressurized cooling system consisting of a heat exchanger, water pump, coolant throttling valve, sight glass, and tower (see Fig. 9). Use American Standard Schedule 40, or equivalent, 3/4-in. non-galvanized pipe fittings and apply sealant to the threads during assembly.

6.2.5.1 Use a water-cooled heat exchanger. A heat exchanger of this type, suitable for this application, is available as American Heat Exchanger, Part Number 5-030-03014-011.^{8,20}

6.2.5.2 Install a 3/4-in. gate-type coolant throttling valve on the output side of the coolant pump to maintain the specified temperature differential between the coolant flowing into, and that flowing out of, the power section jacket.

¹⁸ The sole source of supply of Daniels flow sections the oil filter known to the committee at this time is Daniel Flow Products Inc., Flow Measurement Products Div., P.O. Box 19097, Houston, TX 77224; Parker Hanifin Corp., Racor Division, 3400 Finch Road, Modesto, CA 95350.

¹⁹ The sole source of supply of Rosemount transducers known

¹⁹ Aeroquip 3/8-in. (10-mm) (inside diameter) hydraulic hose has been used successfully to plumb the committee at this time is Rosemount Inc., 4001 Greenbriar, Ste 150B, Stafford, TX 77477; oil filter and oil heater; select hose of a specification to cover temperatures and pressures encountered in Sequence VIII engine oil testing.

²⁰ The sole source of supply of Vaccum aspirators the heat exchanger known to the committee at this time is McKenzie Air Industries, 18523 HI 35 North, Shertz, TX 78108; Compressor Engineering, 625 District Dr., Itasca, IL 60143.

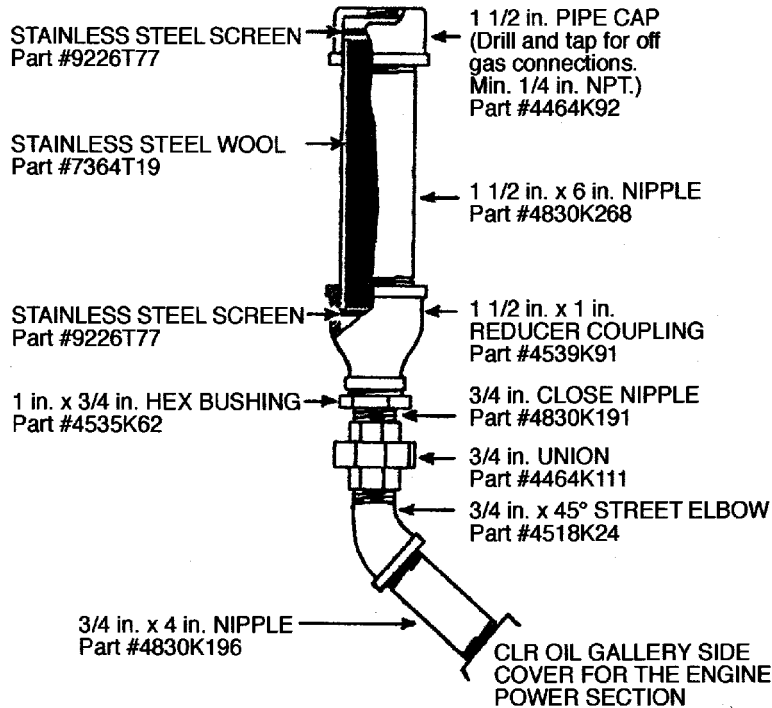

FIG. 5 Crankcase Breather Detail

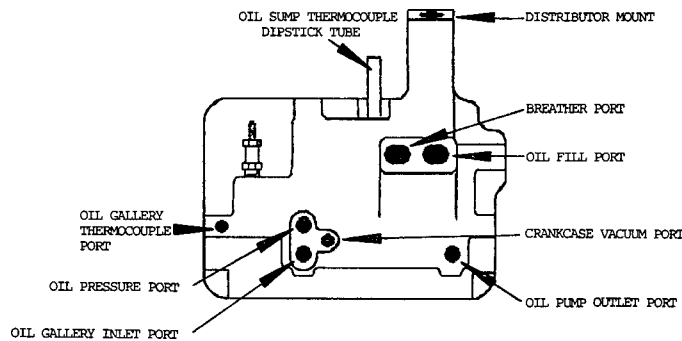

FIG. 6 Oil Gallery Side Cover

6.2.5.3 The coolant pump is to be an electrically driven centrifugal pump with a flow of approximately 18.9 L/min at 95.5 kPa of water head pressure. The Grainger²¹ Part No. 1P831 has been found suitable.

6.2.5.4 Install a sight glass^{8, 22} located downstream of the cylinder head to permit detection of air entrainment.

6.2.5.5 Fabricate the tower using non-galvanized metal. Make it approximately 90 mm in diameter and 410 mm long. Fashion a loose-fitting cover for it. Install a level gage, positioned to give a mid-scale reading when the system is filled. The system shall have a minimum capacity of 7.5 L.

6.2.6 *Exhaust System*— Use either a water-quenched system or a dry system.

6.2.7 *Ignition System*— An electronic ignition system is required. The required system is illustrated in Figs. A10.1-A10.10. Other electronic ignition system configurations shall be reviewed and approved by the TMC and the Sequence VIII Surveillance Panel, prior to use.

6.3 *Instruments and Controls:*

6.3.1 *Dynamometer*— Use a dynamometer and control system capable of maintaining the specified engine operating test conditions (see Section 11). Speed measurement shall have a minimum accuracy of $\pm 0.5\%$ of reading, and load minimum measurement accuracy of $\pm 2\%$ of reading.

²⁴ The sole source of supply of Sensotec transducers known to the committee at this time is Sensotec Inc., 1200 Chesapeake Ave., Columbus, OH 43212.

²¹ Any Grainger national branch location.

²² The sole source of supply of a sight glass of this type-o, suitable for this applicateion (Gitts-Part No. 3063-27) known to the committee at this time is Parker-Hanifin Corp., Racor Division, 3400 Finch Road, Modesta, CA 95350; Edward Fisher Co., 118 S. Wabash, Chicago, IL 60616.

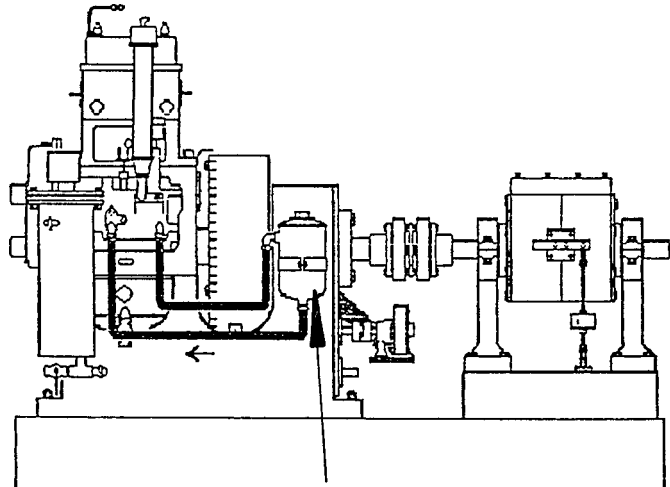

OIL FILTER
FIG. 7 Oil Filter Installation

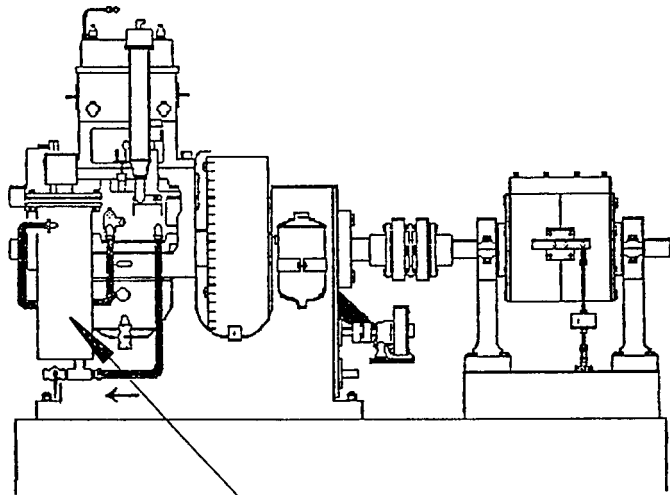

OIL HEATER
FIG. 8 Oil Heater Installation

6.3.2 *Fuel Flowmeter or Fuel Weigh System*—Use a system with a range of 0 to 4.5 kg/h, and having a minimum accuracy of 1 % reading and 0.5 % repeatability.

6.3.3 *Air-Fuel Ratio Measurement System*—Use a system with a calibration capability of the equivalent of ± 0.5 air-fuel ratio number. The following are acceptable methods for determination of air-fuel ratio:

6.3.3.1 *Calibrated Electronic Exhaust Gas Analyzer*—Use sample gases for the calibration. Follow the directions in Annex A12 to determine air-fuel ratio.

6.3.3.2 *AFR Analyzer/Lambda Meter*—The air fuel ratio (AFR) analyzer shall have a measurement range of 11.00 to 18.00 for AFR with 1.85 H/C and 0.00 O/C, where: H is hydrogen, C is carbon and O is oxygen.

6.3.3.3 When a Lambda meter is used, the exhaust sensor location is to be within 150 ± 50 mm of the cylinder head exhaust outlet mating surface.

6.3.4 *Pressure Measurement:*

6.3.4.1 *Crankcase Vacuum*—As shown in Fig. 3, connect a line trap and an appropriate sensor to the crankcase at the hole above and to the right of the oil heater inlet hose connection on the oil gallery side cover. See Fig. 6 for the location of the crankcase vacuum port. Measurement resolution of 50 Pa and 1 % accuracy in the specified range of $.500 \pm .120$ kPa are required.

6.3.4.2 *Exhaust Back Pressure*—Connect an appropriate sensor to the exhaust back-pressure tap at a point within 100 mm of the cylinder head exhaust flange. Sensor accuracy of ± 10 % of reading and resolution of 340 Pa are required.

6.3.4.3 *Intake Manifold Vacuum*—Measure the intake manifold vacuum at the elbow of the intake manifold by means of a sensor having an accuracy of 1 % and a resolution of 680 Pa.

6.3.4.4 *Oil Pressure*—Measure the oil pressure with an appropriate sensor having an accuracy of ± 2 % and a resolution of 7 kPa, connected to the point shown in Fig. 6.

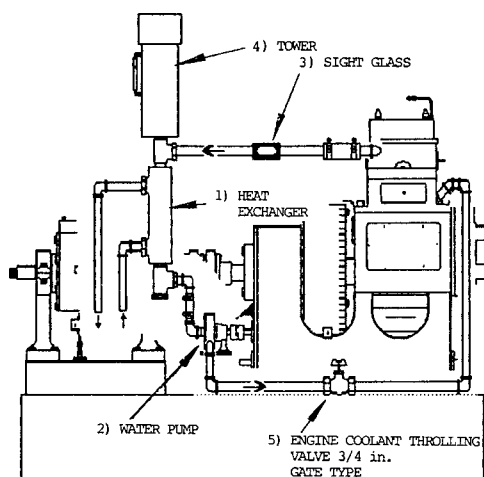

FIG. 9 Cooling System

6.3.5 *Temperature Measurement*—The test requires the accurate measurement of oil and coolant temperature. Exercise care to ensure temperature measurement accuracy. Follow the guidelines of Research Report RR:D02:1218.²³

6.3.5.1 Check all temperature devices for accuracy at the temperature levels at which they are to be used. Iron-Constantin (Type J) thermocouples are specified for temperature measurement.

6.3.5.2 All thermocouples shall be premium grade, sheathed types with premium wire. Use thermocouples of 3.2 mm diameter. Thermocouple lengths are not specified but shall not have greater than 5 cm of thermocouple sheath exposed to ambient laboratory temperature.

6.3.5.3 Some sources of thermocouples that have been found suitable for this application are, Leeds and Northrup, Conax, Omega, Revere, and Thermo Sensor.

6.3.5.4 System quality shall be adequate to permit calibration to ± 0.56 °C for individual thermocouples.

6.3.6 *Thermocouple Location and Length* —All thermocouple tips shall be located in the center of the stream of the medium being measured unless otherwise specified.

6.3.6.1 *Coolant Temperatures*—The thermocouples used to measure the coolant inlet and outlet temperatures are to be located within 100 mm of the inlet and outlet bosses on the power section.

6.3.6.2 *Air Inlet Temperature*—Measure the air inlet temperature with an exposed thermocouple or thermometer located at the center of the air tube, 38 mm above the carburetor air horn.

6.3.6.3 *Oil Gallery Temperature*—Measure oil gallery temperature at the front main bearing passage (see Fig. 6). The immersion length for these thermocouples is 35 mm.

6.3.6.4 *Crankcase Off-Gas Temperature Measurement*—Measure the off-gas temperature at the outlet side of the crankcase breather assembly. Fig. 3 shows a recommended system.

6.4 *Procurement of Parts*—Obtain information on the CLR Oil Test Engine (see 6.1.1) and parts for it from TEI. Users of this test method shall comply with CLR Oil Test Engine Shop Manual⁵ and the latest supplements (Information Letters and Memoranda) available from the TMC.

7. Reagents and Materials

7.1 Reagents:

7.1.1 A 1:3 mixture of hydrochloric acid and deionized water. (**Warning**—The laboratory shall establish proper safety procedures for handling and disposal of this reagent.)

7.1.2 A 1:8 mixture of baking soda and water. (**Warning**—The laboratory shall establish proper safety procedures for handling and disposal of this reagent.)

7.2 Cleaning Materials:

7.2.1 *Abrasive Paper*,²⁴ 400-, 600-, 800-grit, wet or dry.

7.2.2 *Crocus Cloth*.²⁴

7.2.3 *Mylar Tape*.²⁴

²² Aeroquip 3/8-in. (10-mm) (inside diameter) hydraulic hose has

²³ Supporting data have been used successfully to plumb the oil filter filed at ASTM International Headquarters and oil heater; select hose of a specification to cover temperatures and pressures encountered in Sequence VIII engine oil testing; may be obtained by requesting Research Report RR: D02-1218.

²⁴ The sole source of supply of the heat exchanger known to the committee at this time is Compressor Engineering, 625 District Dr., Itasca, IL 60143; sand paper and Mylar tape may be obtained from many commercial sources.

7.2.4 *Organic Solvent-Penmul L460*^{8,25} (**Warning**—Combustible. Health hazard.).

7.2.5 *Pentane (Solvent)*, 99 + %, high-performance liquid chromatography grade (**Warning**—Flammable. Health hazard).

7.2.6 *Stoddard Solvent*,^{8,26} Specification D 235, Type I (**Warning**— Combustible. Health hazard).

7.2.7 *Tap Water*, heated to between 66 and 82°C.

7.3 *Expendable Power Section-Related Items*:

7.3.1 *Sealing Compounds*—Approved sealing compounds, including pipe thread compound and gasket cement are:

7.3.1.1 *Perfect Seal Sealant No. 4*,²⁷

7.3.1.2 *Permatex Ultra Blue 77B*,²⁷

7.3.1.3 *Permatex 3H, Permatex High Tack 99 MA*,²⁷

7.3.1.4 *Dow Corning High Vacuum Grease*,²⁷

7.3.1.5 *Dow Corning RTV Gray 3154*, and²⁷

7.3.1.6 *Petroleum Jelly*.²⁷

7.3.2 *Power Section Build-Up Oil*.²⁸

7.4 *Power Section Coolant*—Use deionized or distilled water for the power section coolant, plus a suitable inhibitor such as Pencoool 2000^{8,29} at 31 mL of Pencoool 2000/L. Such water purchased from a commercial source is suitable.

7.5 *Reference Oils*— Conduct test periodically on reference oils supplied by the TMC, to document the test severity of a given power section and test stand, and the overall operation of the test. Use 8 L (2 gal.) of reference oil for each test.

7.6 *Test Fuel*—Use Haltermann Products KA24E Test Fuel.^{8,30} The specification for KA24E Test Fuel is available from Haltermann Products. (**Warning**—Flammable. Health hazard.)

7.6.1 *Fuel Batch Approval*—New batches of KA24E Test Fuel are approved for use by the Subcommittee D02.B0.01 Sequence IVD IVA Surveillance Panel.³¹

7.6.2 *Fuel Batch Analysis*—Details are available from Subcommittee D02.B0.01 Sequence-~~IVD IVA~~ IVA Surveillance Panel.

7.6.3 *Laboratory Storage Tank Fuel Analysis*—Details are available from Subcommittee D02.B0.01 Sequence-~~IVD IVA~~ IVA Surveillance Panel.

7.6.4 *Fuel Batch Shipment and Storage* —Details are available from Subcommittee D02.B0.01 Sequence-~~IVD IVA~~ IVA Surveillance Panel.

8. Test Oil Sample Requirements

8.1 *Selection*—The sample of test oil shall be representative of the lubricant formulation being evaluated and shall be uncontaminated.

8.2 *Inspection*—New oil sample baseline inspection requirements are described in 12.1.1.

8.3 *Quantity*—Approximately 7 L of fresh oil is required to complete the test. It is recommended that a test laboratory have approximately 8 L of oil on hand when starting a test to allow for inadvertent losses.

9. Preparation of Apparatus

9.1 *Test Stand Preparation*:

9.1.1 *Instrumentation Calibration* —Check the calibration of temperature sensors, flowmeters, pressure sensors, and dynamometer load indicator as required by the type of instrumentation being used. Details on calibration, of both power section and test stand, and of instrumentation, are given in 10.2.

9.1.2 *Preventive Maintenance*—Refer to and comply with “instructions for Assembly and Disassembly of the CLR Oil Test Engine” regarding details pertaining to care and maintenance of the accessory case.

9.2 *Conditioning Test Run on Power Section*—A new power section cannot be calibrated, nor is it suitable for test purposes, until a full-length, conditioning test run has been conducted on the power section. The conditioning test run is required to prepare

²⁵ Any Grainger national branch location.

²⁵ The sole source of supply of Penmul L460, a registered trademark, known to the committee at this time is Penetone Corp., 7400 Hudson Ave., Tenafly, NJ 07670.

²⁶ The sole source of supply of a sight glass of this type, suitable for this application (Gitts Part No. 3063-27) known to the committee at this time

²⁶ Stoddard Solvent, Specification D 235, Type I, is Edward Fisher Co., 118 S. Wabash, Chicago, IL 60616; available from petroleum solvent suppliers.

²⁷ Supporting data have been filed at ASTM International Headquarters and

²⁷ These may be obtained by requesting Research Report RR:D02:1218; from many commercial sources.

²⁸ The sand paper

²⁸ Noncompounded oil ISO VG 46 (SAE 20) (see Classification D 2422) is available through lubricant marketers. One supplier is Exxon-Mobil Oil Corp. The Exxon-Mobil product is designated EF-411, and Mylar tape may be obtained is available from many commercial sources. Exxon-Mobil Oil Corp., P.O. Box 66940, AMF O'Hare, IL 60666, Attn: Illinois Order Board.

²⁹ The sole source of supply of Penmul L460, a registered trademark, Pencoool 2000 known to the committee at this time is Penetone Corp., 7400 Hudson The Penray Co, Inc., 1801 Estes Ave., Tenafly, NJ 07670; Elk Grove, IL 60007.

³⁰ Stoddard Solvent, Specification D 235, Type I,

³⁰ The sole source of supply of Haltermann Products KA24E Test Fuel known to the committee at this time is available from petroleum solvent suppliers: Haltermann Products, Ten Lamar, Ste 1800, Houston, TX 77002.

³¹ These may be obtained from many commercial sources.

³¹ Contact the TMC for address information for the D02.B0.01 Sequence IVA Surveillance Panel.

the cast iron parts of such a power section, and the oil used for the run is a reference oil designated by the TMC. Upon completion of the conditioning run, the power section shall be reconditioned as described in 9.4 before conducting a test. (A conditioning run on a reference oil shall not qualify as a reference test. Testing can commence only after a conditioning run and a reconditioning.)

9.3 *General Power Section Rebuild Instructions*—Assemble the power section according to the detailed instructions found in the assembly manual. Compliance with all provisions of the assembly manual is mandatory. However, in cases of disparity, the explicit instructions contained in this test method take precedence over the service manual. Information letters and memoranda issued by the TMC shall supersede this manual. Failure to follow the instructions provided in this document and related TMC information letters or memoranda, or both, may cause incorrect test results.

9.4 *Reconditioning of Power Section After Each Test*—Recondition a previously used power section before the start of a new test. Power sections previously used with leaded fuel shall be decontaminated using the procedure shown in Annex A13 before use. Follow the parts replacement and cleaning procedures described in the following sections.

9.4.1 *New Parts*—Use the following new parts:

9.4.1.1 Piston and piston ring assembly,

NOTE 2—A used piston may be reused if it meets the requirements of 6.1.4.1.

9.4.1.2 H-24 alloy connecting rod test bearing,

9.4.1.3 All gaskets, seals, O-rings, and

9.4.1.4 All parts that are excessively worn or that do not permit maintenance of the operating clearances specified in this method or in “Instructions for Assembly and Disassembly of the CLR Oil Test Engine.”

9.4.2 *Documented Parts*—The parts supplier will provide records, stating source codes and additional information such as batch code, lot number, and so forth. It will be the responsibility of the laboratory to maintain records documenting these parts by proper identification numbers. The parts that require documentation are: (1) crankshafts, (2) camshafts, (3) connecting rod bearings, (4) crankshaft main bearings, (5) camshaft bearings, (6) piston rings, (7) connecting rods, (8) pistons, and (9) cylinder sleeves.

9.4.2.1 *Critical Parts*—The crankshaft and connecting rod are considered critical parts. If either is replaced during a reference period it will void the calibration status of the stand/power section. A reference oil test meeting the calibration requirements of Section 10 is required before continuing non-reference oil testing.

9.4.3 *Parts Cleaning Procedures:*

9.4.3.1 *Oil Pump, Oil Pressure Regulator, Distributor, and Crankcase Breather*—Remove the distributor and crankcase breather. Remove the oil pump and oil pressure regulator with the oil gallery side cover plate. Clean this cover plate thoroughly using Penmul^{8,29}(²⁵ (**Warning**—Combustible. Health hazard.) and a fiber brush or swab, then rinse the cover plate with tap water heated to 65 to 82°C (150 to 180°F), and rinse it again with Stoddard Solvent^{8,30}(²⁶ (**Warning**—Combustible. Health hazard.)). Carefully spray the oil pump, oil pressure regulator, and distributor with Stoddard Solvent to remove deposits. Disassemble, inspect, and clean the crankcase breather with Stoddard Solvent.

9.4.3.2 *Power Section*—Dismantle the power section completely before each test and thoroughly clean the parts by soaking them in Penmul for a minimum of 4 h. Remove remaining deposits on the crankshaft using fine or very fine 3M Scotch Brite pads. After the minimal 4-h soak and cleaning period, rinse the parts in hot tap water (65 to 82°C) to remove all traces of Penmul, and then rinse them with Stoddard Solvent.^{8,30}(²⁶ (**Warning**—Insufficient rinsing may allow Penmul carryover to the test oil causing increased severity in H-24 alloy bearing weight loss.)

9.4.3.3 *Alternative Methods*—The above-noted parts may be cleaned using a heated bath or temperature controlled automated parts washer. Allow the parts to cool before assembly or measurement. Protect parts cleaned by either method in accordance with 9.4.3.4.

9.4.3.4 *Protection of Parts*—Immediately after cleaning, protect all parts against moisture and contamination by the use of build-up oil, vapor-proof plastic bag, or both. Give special attention to cleaning the following: (1) sludge trap, (2) oil passages in crankshaft, in cylinder block, in crankcase and to valve lifters, (3) oil passage to rocker assembly, and (4) oil passage to timing gear oil jet.

9.4.3.5 *Oil Heater Cleaning*—Prior to each reference oil test, clean the oil heater case and inner cartridge with Penmul to remove all residues, deposits, and foreign material. Use a wire brush or emery cloth as needed to completely remove residues and deposits, then rinse with hot tap water and spray the case and cartridge with Stoddard Solvent and air dry. Prior to every test between references, the oil heater may be cleaned by circulating Stoddard Solvent through it for 15 min and then air drying.

9.4.3.6 *H-24 Alloy Test Bearing*—Mark the bearing before using it in a test with the letters T (top) and B (bottom) on the backs of the bearing tangs, using a vibrating engraver. Make no other marks on the bearing until after the final weighing. Prior to initial weighing and prior to weighing at the end of a test, clean the bearing halves according to the procedure given in Annex A9. (Fresh, clean Stoddard Solvent and pentane shall be used for cleaning.) (**Warning**—Flammable. Health hazard.)

9.4.4 *Cylinder Liner Finishing*—To minimize the effect of changes in oil consumption, a new TEI cylinder liner shall be finished according to the honing procedure in Annex A6. The method for finishing a used liner is at the laboratory’s judgment.

9.4.4.1 *Cleaning Procedure and Rust Prevention*—After the desired finish is achieved, spray the liner with Stoddard Solvent, and air dry it. Apply build-up oil to the liner surface. Wipe the liner interior with a cloth or paper towel wetted with build-up oil until the wiping material appears clean after wiping. Coat the liner with build-up oil.

9.4.5 *Piston-to-Sleeve*— Determine the piston-to-sleeve clearance in accordance with the procedure given in Annex A4.

9.4.6 *Crankshaft Rear Seal Surface Conditioning*—Control of oil and air leakage at the crankshaft rear seal may be improved if the crankshaft rear seal surface is conditioned prior to each test in accordance with the recommendations of Annex A15.

9.4.7 *Crankshaft Journal Conditioning* :

9.4.7.1 Use crankshafts with all journals having out-of-round measurements of 0.025 mm or less.

9.4.7.2 Since the test method is primarily designed to measure bearing weight loss, maintain the crankshaft rod bearing journal such that weight loss due to abnormal mechanical wear is minimized. Exercise care when handling the crankshaft to prevent nicking the journal surfaces. Should nicks be observed, lightly dress the journal with a dressing stone. Remove as little metal as possible. Observe bearing wear pattern for the test following this process to confirm that mechanical wear is at a practical minimum.

9.4.7.3 Polish the connecting rod bearing journal according to the following guidelines. Mount the crankshaft on centers or position the main bearing journals in V-blocks. Prepare strips of polishing medium (only a wet/dry, silicon carbide, 400, 600 and 800 grit abrasive paper, standard crocus cloth, or Mylar 3m tape is approved for use) 13 mm wide by 0.9 to 1.2 m long. It is necessary to wet the strip of crocus cloth or abrasive paper with build-up oil or the Mylar tape with Stoddard Solvent. Wrap the strip 1½ times around the journal to provide a minimum of 360° contact between the cloth and journal. The Mylar tape will not slide over itself so only wrap it 180°. Stroke the journal with the cloth or abrasive paper by alternately pulling on the two ends of the strip while maintaining a light tension on the strip, and while traversing across the journal. Do not dwell in the center of the journal. Rotate the crankshaft 90° between each traverse. Repeat four times. If abrasive paper is used, complete the fourth and final polishing process using crocus cloth or Mylar tape.

9.4.7.4 Alternatively, rotate the crankshaft (for example, with a metal turning lathe) at about 120 r/min during the polishing process. Polishing for approximately 20 to 30 s, while traversing the cloth across the journal, has been found to be effective for this process. Do not dwell in the center of the journal. No other method of polishing process is permitted.

9.4.7.5 Repeat the polishing procedure with dry crocus cloth or Mylar tape.

9.4.7.6 To confirm the trueness of the journal, visually check the journal with a straight edge 30.12 mm long; this length equals the width of the connecting rod bearing. Place a bright light source near the crankshaft on the side opposite your eyes. Hold the straight edge axially against the journal and inspect for light leakage between the straight edge and the journal surface, at 30° increments around the journal. If light leakage is observed, measure the journal diameters at the large and small-diameter points, determine the axial distance between the two measurement points, and calculate the taper (using half of the diametrical difference) of the journal between the points. Discard any crankshafts having a connecting rod journal taper larger than 0.013 mm/25.4 mm. (Experience has shown that mechanical bearing wear with such crankshafts is unacceptably high.) The use of technology, such as surface profile measuring equipment is acceptable if approved by the TMC.

9.4.7.7 Resizing (refinishing) of the connecting rod journal is allowed only as stated in 6.1.3.2.

9.4.7.8 Determine the connecting rod bearing clearance and journal taper according to the procedure given in Annex A1, or an equivalent method approved by the TMC, prior to the initial weighing of the bearing halves. Perform the connecting rod clearances prior to the initial weighing of the bearing halves.

9.4.7.9 Determine the main bearing clearance according to the procedure given in Annex A2 or an equivalent method approved by the TMC. Perform the connecting rod clearance measurements prior to the initial weighing of the bearing halves.

9.4.7.10 After preparing the crankshaft according to 9.4.7.1-9.4.7.9, clean it thoroughly. Either pressure spray it with Stoddard Solvent or brush it with Stoddard Solvent, and air dry.

9.4.8 *Camshaft Journal Conditioning* —The camshaft journal-to-bearing clearance must be within the range of 0.030 to 0.132 mm. [However, to maintain good oil pressure control when using low-viscosity oils, it may be necessary to reduce this clearance to 0.030 to 0.081 mm.] A suggested method for salvaging out-of-limit camshaft bearing journals or for decreasing the camshaft journal clearance is provided in Appendix X2.

9.4.9 *Power Section Valve Clearances* —Make the appropriate adjustments during power section reassembly to obtain the clearances shown in the “Instructions for Assembly and Disassembly of the CLR Test Engine.” If specifications do not include an inch tolerance, the intent is to meet this value.

9.4.10 *Power Section Assembly Torque Specifications*—During power section assembly, use the torque specifications shown in the “Instructions for Assembly and Disassembly of the CLR Test Engine.”

9.4.11 *Connecting Rod Reconditioning* —When reconditioning connecting rods, the bore diameter shall be within the range of 57.8231 to 57.8358 mm.

10. Calibration

NOTE 3—The ASTM Test Monitoring Center Calibration Program (Annex A3) dictates specific procedures which involve coordination with the TMC in order to obtain calibration status of a test power section and a test stand. The information given in the following sections provides a summary of the calibration process required.

10.1 *Power Section and Test Stand Calibration*—Calibrate power sections in combination with test stands by running tests on reference oils (see 10.1.3 for frequency). The purpose is twofold: (1) to verify standardized engine operation, and (2) to document a laboratory’s severity level for given combinations of power sections and test stands. (A test of a non-reference oil shall be conducted only on a given combination of power section, test stand, and bearing batch lot, which has been previously calibrated.)

Conduct all non-reference oil and reference oil tests in the same manner.

10.1.1 *Reference Oils*— Obtain reference oils for calibration use from the TMC. Oils are available representing various levels of performance. See 14.1 for performance data.

10.1.2 *Test Numbering*— Calibration of power sections and test stands is closely related to test numbering; that is, the test number assigned to a test is a function of the calibration test recently conducted. Number each Sequence VIII Engine Oil Test by assigning it a test number that identifies the test stand number, the power section number, the number of tests conducted on the power section since the last successful reference oil test on that power section, and the total number of runs on the power section. The only exception to this format is that the sequential total number of runs on the power section shall be followed by the letter A for the first rerun, B for the second, and so forth, for an invalid or unacceptable reference oil test.

10.1.3 *Reference Oil Test Frequency* :

10.1.3.1 Using blind reference oils supplied by the TMC, calibrate each power section/test stand combination following each 15 test starts or upon the expiration of the 6 month power section/test stand time period, whichever occurs first. When a Sequence VIII oil test is terminated after the first 10-h interval to determine the stripped viscosity of a multiviscosity-graded oil, on a calibrated Sequence VIII power section/test stand, the test is counted as one of 15 test starts allowed per reference period. Also, any tests exceeding intervals of 40 h shall be counted as more than one test each time it exceeds 40 h. For example, 0 to 40 or less h equals one test; 41 to 80 h equals two tests; 81 to 120 h equals three tests, and so forth.

10.1.3.2 When circumstances develop which are beyond a laboratory's control, such as fuel or parts shortages, calibration periods and the number of test starts between calibrations may be adjusted. Adjustments to calibration periods and the number of test starts between calibrations shall be approved by the TMC and the Sequence VIII Surveillance Panel before additional test starts are conducted. Make a note on the form shown in Fig. A16.7 in the final test report, stating that the test was conducted on a power section/test stand in which calibration requirements were adjusted and, also, the reason for the adjustment.

10.1.3.3 Laboratories running non-standard Sequence VIII tests shall contact the TMC before resuming calibrated Sequence VIII testing with the test stand or power section (or both) involved. Depending upon the modifications to the power section or test stand (or both) and the time period of non-standard testing, test stand checks or reference oil tests, or both, may be required before resumption of calibrated testing.

10.1.4 *Reference Oil Test Acceptance and Severity Monitoring*:

10.1.4.1 The TMC maintains records of reference oil test activity, analyzes severity trends, gives reports at ASTM meetings, and assists laboratories in the technical conduct of tests. (See Appendix X1 for a more detailed presentation of the TMC role.)

10.1.4.2 Submit all reference oil test reports to the TMC for review and acceptance. (See LTMS for reference oil test acceptance criteria³²). The test data Test Results sheet for test reports on engine oils other than reference oils (Fig. A16.4) shall include the test number and completion date of the power section reference oil test(s) used to calibrate the power section/test stand used for the test.

10.1.4.3 Failure of a reference oil test to meet LTMS control charts limits can be indicative of a false alarm, or a power section/test stand, laboratory or industry problem. When this occurs, the laboratory, in conjunction with the TMC, shall attempt to determine the problem source. Input from industry expertise (ASTM Technical Guidance Committee, the Sequence VIII Surveillance Panel, Registration Systems, Inc., and so forth) may be solicited to help determine the cause and extent of the problem.

(1) In the event of a failed reference oil test, the calibration status of the power section or test stand, or both, shall first be reviewed before subsequent tests are conducted. If the TMC determines the problem is a false alarm, then there is no impact on non-reference tests running in the laboratory. If it is determined that the problem is related to the power section or test stand, non-reference tests run during the problem period in that power section or test stand, or both, shall be reviewed for validity taking into account the related new information.

(2) If it is determined that the problem is related to the laboratory, all non-reference oil tests run in the laboratory during the problem period shall be reviewed for validity taking into account the related new information.

(3) If it is determined that the problem appears to be industry-wide, the ASTM Sequence VIII Surveillance Panel shall be requested to develop a resolution.

10.2 *Instrumentation Calibration* —Calibrate the following instrumentation, immediately prior to each reference oil test, with the exception of a test stand where reference oil tests are conducted with multiple power sections. For a test stand using multiple power sections, the test stand instrument calibration may be extended by 14 days. For example, a reference oil test can be conducted in the same test stand with a second power section without calibrating the test stand instrumentation if the reference oil test is started within 14 days of the previous test stand instrument calibration. Unless otherwise specified in this test method, follow the instructions provided by the manufacturers of the instruments regarding the method of calibration. In calibrating each instrument, use certified reference standards having known values covering the range of measurements to be encountered in using this test method, and having tolerances less than those of the measurement tolerances specified in this test method. Retain the calibrations records for a minimum of 24 months.

³² Noncompounded oil ISO VG 46 (SAE 20) (see Classification D 2422)

³² The document, "Lubricant Test Monitoring System," is available through lubricant marketers. One supplier is Exxon-Mobil Oil Corp. The Exxon-Mobil product is designated EF-411, and is available from Exxon-Mobil Oil Corp., P.O. Box 66940, AMF O'Hare, IL 60666, Attn: Illinois Order Board, the TMC.

- 10.2.1 Engine load measurement system,
- 10.2.2 Engine speed indicator,
- 10.2.3 Fuel flowmeter or weighing scale,
- 10.2.4 Temperature sensors and measurement system,
- 10.2.5 Electrical wattmeter (only if used),
- 10.2.6 Pressure gages,
- 10.2.7 Crankcase off-gas flowmeter,
- 10.2.8 Crankcase ventilation air flowmeter, and
- 10.2.9 Rocker cover air flowmeter.
- 10.3 *Calibration of AFR measurement Equipment:*
- 10.3.1 *Lambda Meters*, prior to each reference oil test.
- 10.3.2 *Exhaust Gas Analysis Meters*, prior to each reading zero and span.
- 10.4 Calibrate torque wrenches every six months.

11. Engine Operating Procedure

- 11.1 *Run-In and Flush*— At the beginning of each test, perform the following 4-h run-in and ~~2-h~~ 1/2-h flush:
 - 11.1.1 Install the Racor oil filter bypassing the oil heater (see Fig. 7). Use a new/clean filter screen (28 μm) for each new test run-in.
 - 11.1.2 Charge the power section with 2840 mL of fresh test oil. Record the date and time that the oil is poured into the engine. These are considered the test start date/time. Prior to starting the engine and any restarts during the 4-h run-in, perform the oil priming procedure in Annex A7.
 - 11.1.3 Operate the power section for 4 h according to the schedule in Table 1. Maintain the oil gallery temperature no higher than 107.0°C, the oil gallery pressure at 280 ± 10 kPa, and the jacket outlet temperature no higher than 93.5°C. Record data at least hourly using a form of the type shown in Fig. X3.1.
 - 11.1.4 Shut down the power section after four running hours. Immediately move the piston to top dead center (TDC) on the compression stroke, and drain the crankcase for 10 min. Remove the crankcase breather tube to vent the power section to atmosphere during drain periods.
 - 11.1.5 After the 4-h run-in, add the oil heater (Fig. 8). The oil heater remains in the oil circuit for the flush and steady-state portions of the test procedure. The external oil outlet shall pass through the heater, then the Racor filter before returning to the engine.
 - 11.1.6 Charge the power section with 1660 mL of fresh test oil. Prior to starting the engine and any restarts during the ~~2-h~~ 1/2-h flush, perform the oil priming procedure in Annex A7.
 - 11.1.7 Flush the power section for ~~2~~^{1/2} h under the following operating conditions: 3150 ± 25 r/min, 3.73 ± 0.15 kW, $35 \pm 1^\circ$ before top dead center (BTDC) spark advance, 107.0°C maximum oil gallery temperature, 93.5°C maximum water jacket outlet temperature, and 280 ± 10 kPa oil gallery pressure. Do not energize the oil heater during this period. Record the operational data prior to shutdown using forms of the type shown in Figs. X3.1 and X3.2.
 - 11.1.7.1 *Downtime Limits, Run-in and Flush*—During the run-in interval and the flush interval (11.1.3) no more than 4 h of off-test time are allowed. No more than one emergency shutdown is allowed. No more than two total shutdowns are allowed.
 - 11.1.7.2 During the shutdown between the 4-h run-in and ~~2-h~~ 1/2-h flush, consider any time in excess of 85 min as off-test time counted against the ~~4~~ 2 h limit listed in 11.1.7.1.
 - 11.1.7.3 During the shutdown after the ~~2-h~~ 1/2-h flush, consider any time in excess of 145 min as off-test time counted against the 2-h limit for the first interval listed in 11.1.7.
 - 11.1.8 Shut down the power section; immediately move the piston to TDC on the compression stroke, and drain the crankcase and oil heater for 10 min. Replace or clean the filter screen in the Racor filter. An alternate method of having two Racor filters is allowable, one used for run-in and flush and another for test.
- 11.2 *Test Operating Conditions*—Throughout the remainder of the test, operate the power section under the conditions shown in Table 2.
 - 11.2.1 *Downtime During the 40-h Test Conditions*—During the first 10-h of test conditions only one shutdown or one emergency shutdown is allowed and the total off-test time shall not exceed 2 h. During the 40-h test, no more than 6 h of off-test time are allowed. During the 40-h of test conditions no more than two emergency shutdowns are allowed and no more than four total shutdowns are allowed.
 - 11.2.2 *Warm-up Schedule*— Charge the power section with 1660 mL of fresh test oil. Prior to starting the engine and any restart during the 40-h test, perform the oil priming procedure in Annex A7. Start the engine and bring engine speed up to 3150 r/min. Follow the schedule in Table 3. When restarting the power section after any unscheduled or emergency shut downs, start the warm-up at the oil gallery temperature recorded when the engine is restarted and adjust the heater wattage or temperature set point, in accordance with Table 3. For example, if the oil gallery temperature is 123.9 °C when the engine is restarted, set the warm-up condition at 1900W or 132.2 °C for 10 min as shown in Table 3. The warm-up shall proceed from this point and continue with the required steps in Table 3.
 - 11.3 *Air-Fuel Ratio and Spark Advance* —Record and adjust, if necessary, the air-fuel ratio and spark advance at h 1, 10, 20

TABLE 3 Power Section Warm-up Schedule

Time, min	Total time, min ^A	Heater Wattage ^B	Temperature Set Point ^B
15	15	1000	101.7°C (215°F)
10	25	1300	112.8°C (235°F)
10	35	1600	123.9°C (255°F)
10	45	1900	132.8°C (270°F)
15	60	2200, if needed	135.0 or 143.3°C (275 or 290°F) ^C

^A Steady-state test time does not include warm-up time; rather, it begins only when the specified oil gallery temperature is reached.

^B Either heater wattage or temperature set point control may be used for warm-up operation.

^C As appropriate from test oil viscosity grade. See Table 2.

and 30. This is the minimum requirement. Additional readings are permitted. When determining the air-fuel ratio using the exhaust gas analysis measured by the calibrated electronic method, utilize Table A12.1.

11.4 *Rocker Cover Air, Off-gas, and Blowby Measurement:*

11.4.1 Adjust the rocker cover air control valve as needed to achieve 850 ± 28 standard L/h (SLH) off-gas. Observe and record the rocker cover air flow reading in SLH after the off-gas flow has been adjusted to 850 ± 28 SLH. Convert the observation to standard conditions (101.3 kPa and 21°C) as follows:

$$SLH = ALH \times [((BARO + GAS)/101.32 \text{ kPa}) \times (294.26 \text{ K}/TEMP)] \quad (1)$$

where:

SLH = off-gas, standard L/h,

ALH = actual measured off-gas, L/h,

BARO = barometer reading, kPa,

GAS = gage pressure at inlet of the off-gas measuring device, kPa, and

TEMP = temperature at the inlet of the off-gas measuring device, °K.

11.4.1.1 Adjust the rocker cover air control valve as needed to achieve 850 ± 28 SLH off-gas.

11.4.1.2 Observe and record the rocker cover air flow reading in SLH after the off-gas flow has been adjusted to 850 ± 28 SLH off-gas.

11.4.2 Blowby is the difference between the standardized off-gas flow measurement and the standardized rocker cover airflow measurement.

11.5 *Unscheduled Shutdowns*—There are no scheduled shutdowns during the 40-h at test conditions. Whenever unscheduled shutdowns become necessary, if possible, follow 11.5.1. If unable to follow 11.5.1, the shutdown shall be considered an emergency shutdown.

11.5.1 Turn off the oil heater and idle the power section at 1500 r/min for 10 min. (This action prevents overheating of the oil in the heater.) Allow the rocker cover fresh air input to remain on. Turn off the ignition to stop the engine. It is also acceptable to disconnect the fuel supply and allow the engine to idle to a stop before turning off the ignition. Move the piston to TDC on the compression stroke.

11.6 *Oil Sampling and Oil Addition* —After 10, 20 and 30-h at test conditions, take oil purge, take oil samples and make additions as directed in the following sections.

11.6.1 Purge 60.0 mL of the engine oil into a beaker.

11.6.2 Take a 180.0 mL sample (same location as purge).

11.6.3 Add 240.0 mL of new oil into the engine along with the original purge (60.0 mL).

11.7 *Periodic Measurements:*

11.7.1 Record, using the data log sheet shown in Fig. X3.2, the following data hourly:

11.7.1.1 Engine speed, r/min,

11.7.1.2 Engine load, kW,

11.7.1.3 Fuel flow, kg/h,

11.7.1.4 Oil gallery temperature, °C,

11.7.1.5 Oil heater input, W, (only if used to control temperature),

11.7.1.6 Jacket inlet coolant temperature, °C,

11.7.1.7 Jacket outlet coolant temperature, °C,

11.7.1.8 Oil pressure, kPa,

11.7.1.9 Crankcase vacuum, kPa,

11.7.1.10 Exhaust back pressure, kPa,

11.7.1.11 Intake air temperature, °C,

11.7.1.12 Intake manifold vacuum, kPa,

11.7.1.13 Crankcase off-gas, SLH,

11.7.1.14 Rocker cover fresh air flow, m³/s, and,

11.7.1.15 Blowby, L/h.

11.7.2 Record the following data at test hours 1, 10, 20 and 30:

11.7.2.1 Air-fuel ratio, and,

11.7.2.2 Spark advance.

11.8 *Final Drain and Oil Consumption Computation*—At the completion of the 40th test hour, shut down the engine (see 11.5). Immediately move the piston to TDC on the compression stroke, and drain crankcase, Racor filter and oil heater. Leave the rocker cover air supply on and remove the breather tube to ensure a proper drain. Measure and record the amount of oil drained. The maximum allowable oil consumption is 778 mL.

11.9 *Operational Validity Criteria*—The test laboratory is responsible for determining and documenting the operational validity of every engine test. In order for a test to be operationally valid, the deviation percentage criteria defined in 11.9.1 shall be met. In addition, the test stand, test operation, and test build-up shall conform with the published procedure/standard.

11.9.1 *Deviation Percentage*—Calculate the deviation percentage using the equation:

$$DP = \sum_{i=1}^{i=n} \left[\frac{M_i}{0.5R} \times \frac{T_i}{D} \right] \times 100 \quad (2)$$

where:

DP = deviation percentage,

M_i = magnitude of test-parameter deviation from specification limit at occurrence i ,

R = test parameter specification range,

T_i = length of time that test parameter was outside of specification range at occurrence i ,

n = number of times that a test parameter deviated from test specifications limits, and

D = test or test-phase duration in same units as T_i .

NOTE 4— T_i is assumed to be no less than the recorded-data-acquisition frequency unless supplemental readings are documented.

11.9.1.1 Invalidate any tests exceeding the following deviation percentages:

(a) *Primary Test Parameters (2.5 %)*:

(1) Fuel flow,

(2) Crankcase off gas,

(3) Oil gallery temperature,

(4) Coolant out temperature,

(5) Coolant delta temperature, and

(6) Oil pressure.

(b) *Secondary Test Parameters (5.0 %)*:

(1) Speed,

(2) AFR,

(3) Spark advance,

(4) Exhaust pressure, and

(5) Crankcase vacuum.

11.10 *Test Completion*— Defined the end of test (EOT) time as 25 min after the 40th test hour.

12. Determination of Test Results

12.1 *Oil Sample Analysis*:

12.1.1 Determine the kinematic viscosity of the new oil and 10 h sample at 40 and 100 °C.

12.1.2 Determine the viscosity stability of a multiviscosity-graded oil by measuring the stripped viscosity of a 10-h sample of used oil. See Annex A14 for the specified measurement method.

12.2 *Test Bearing Weight Loss Determination*—Record, in milligrams, the weights of the top and bottom connecting rod test bearing halves within 4 h of conclusion of the test. If this determination is delayed longer than 4 h, the test is invalid. Clean each test bearing half, as described in Annex A9, before weighing. Determine the weight loss of the bearing to the nearest 0.1 mg by subtracting from the initial weights recorded prior to power section run-in.

12.2.1 If applicable adjust the total bearing weight loss, according to the procedure in Annex A5. Record the severity adjustments (SA) in Fig. A16.4, the test report (see Annex A16).

13. Report

~~13.1 The forms required for inclusion in~~

~~13.1 For referenced oil tests, the test standardized report are presented in Annex A16. Editorial conventions concerning form set and data dictionary for reporting test results and for summarizing the preparation of standard report forms shall be determined through contact with the TMC. operational data are required.~~

13.2 Use Forms 1, 2, 4, 5, 6, 7, and 8 (see Figs. A16.1–A16.8, respectively) Annex A16) for initial transmission of reference oil test results to the TMC.

14. Precision and Bias

14.1 *Precision*—Test precision (that is, intermediate precision and reproducibility) is established on the basis of reference oil test results (for operationally-valid tests) monitored by the TMC. The limits, including standard deviations, are given in Table 4. They were computed by the TMC from test results obtained on TMC reference oils 704-1 and 1006 and apply as of June 10, 2000-23, 2003. Respective precision limits were obtained by multiplying respective standard deviations by 2.8.

14.1.1 *Intermediate Precision (I.P.)*—~~The difference between two (formerly called repeatability) Conditions—Conditions where test results are obtained by with the same operator or laboratory on the same oil test method using the same test oil, with changing conditions such as operators, measuring equipment, test stands, test engines, and time.~~

14.1.1.1 *Intermediate Precision Limit (i.p.)* —~~The difference between two results obtained under intermediate precision conditions that would, in the long run, in the normal and correct conduct of this the test method, exceed the limits values shown in Table 4 in only one case in twenty.~~

14.1.2 *Reproducibility Condition*—~~Conditions where test results are obtained with the same test method using the same test oil in different laboratories with different operators using different equipment.~~

14.1.2.1 *Reproducibility Limit (R)*—~~The difference between two single and independent results obtained by different operators working in different laboratories on the same oil using this test method under reproducibility conditions that would, in the long run, in the normal and correct conduct of this the test method, exceed the limits shown values in Table 4 in only one case in twenty.~~

14.2 *Bias*—Bias is determined by applying an acceptable statistical technique to reference oil test results. When a significant bias is obtained, a severity adjustment is permitted for non-reference oil test results. Contact the TMC for TMC Memo 94-200 (Lubricant Test Monitoring System Document).

15. Use of ASTM Rounding

15.1 Follow Practice E 29 (6.4– 6.5) guidelines for rounding of test results, operational parameters, and engine build-up measurements.

16. Keywords

16.1 bearing weight loss; CLR oil test engine; copper-lead bearings; engine oil; oil consumption; Sequence VIII test; shear stability

ANNEXES

(Mandatory Information)

A1. MEASUREMENT OF CONNECTING ROD BEARING CLEARANCE AND JOURNAL TAPER

A1.1 Conduct the connecting rod bearing clearance measurements with the crankshaft, bearing sets, and measuring tools at room temperature.

A1.2 Use measuring tools having an accuracy of at least 0.003 mm.

A1.3 Thoroughly clean the connecting rod bore with Stoddard Solvent and air dry. Use caution not to affect the original surface. Clean the connecting rod bearings according to A9.1. Install the rod bearing halves that are to be used in the test into the proper location (top and bottom as marked). Place the connecting rod into a holding device clamping as close as possible to the large end of the connecting rod to prevent the rod from being twisted during the torquing procedure. Install lower bearing cap and apply 61 N·m torque to the bearing cap bolts.

TABLE 4 Reference Oil Test Precision Limits

Variable	$S_{I.P.}$	<i>I.P.</i>	S_R	<i>R</i>
Variable	$S_{i.p.}$	<i>i.p.</i>	S_R	<i>R</i>
Bearing weight loss, mg	3.87	10.84	3.87	10.84
Bearing weight loss, mg	3.56	9.99	3.56	9.99
Stripped viscosity, cSt at 100°C	0.15	0.42	0.15	0.50
Stripped viscosity, cSt at 100°C	0.13	0.36	0.13	0.36

Note—Legend:

Legend:

$S_{I.P.}$ = intermediate precision standard deviation

$S_{i.p.}$ = intermediate precision standard deviation

I.P. = intermediate precision

i.p. = intermediate precision

S_R = reproducibility standard deviation

R = reproducibility

A1.4 Measure the connecting rod bearing vertical diameter at the two points A and B indicated in Fig. A1.1. Each of the points is located 6.4 mm from each bearing edge. Record the measurements in the appropriate spaces in a table such as Table A1.1. Immediately return the connecting rod bearings to the original container filled with build-up oil after measurements are performed.

A1.5 Mount the crankshaft on a workbench with the axis horizontal and with the connecting rod bearing journal vertically upward, simulating the top-dead-center position in the engine.

A1.6 Measure the diameter of the connecting rod bearing journal of the crankshaft at the points A₁, B₁, A₂, and B₂ indicated in Fig. A1.1. The measuring points are located 9.5 mm from each thrust face. Record the measurements in the appropriate spaces in a table such as Table A1.1.

A1.7 Subtract the diameters to obtain the clearances, as directed in Table A1.1. From the four clearance values thereby determined, select the minimum and maximum values, and enter them in the spaces provided in the table.

A1.8 The minimum and maximum connecting rod bearing clearances determined in A1.7 shall be within the range of 0.061 to 0.076 mm. If they fall outside of this range, select and measure a different crankshaft.

A1.9 Determine the taper of the connecting rod bearing journal by completing Table A1.2. The maximum quotient obtained in Table A1.2 is considered the journal taper. Discard any crankshafts having a connecting rod journal taper larger than 0.0005 mm/mm.

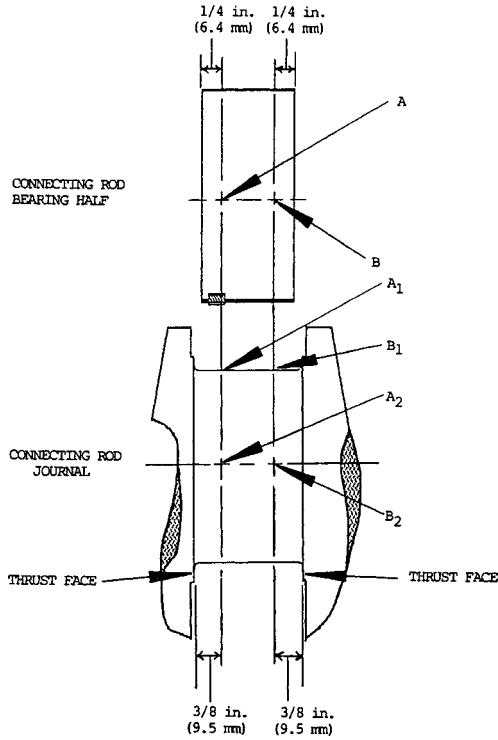

FIG. A1.1 Clearance Measuring Points for Connecting Rod Bearings

TABLE A1.1 Connecting Rod Bearing Clearance^A

A _____	B _____
A ₁ _____	B ₁ _____
A ₂ _____	B ₂ _____
A-A ₁ = _____	B-B ₁ = _____
A-A ₂ = _____	B-B ₂ = _____
min _____	max _____

^A Diameters A₁ and B₁ are measured at points 90° from A₂ and B₂, respectively.

TABLE A1.2 Taper of Connecting Rod Bearing Journal^A

Use measurements from Table A1.1.	
$(A_1 - B_1 = \text{_____}) / 1.372 \text{ in. (34.85 mm)} = \text{_____}$	
$(A_2 - B_2 = \text{_____}) / 1.372 \text{ in. (34.85 mm)} = \text{_____}$	

^A Bearing width = 1.186 in. (30.12 mm). Distance between the measuring points A_1 and B_1 (or A_2 and B_2) is 1.186 in. (30.12 mm) - 2 [$1/4$ in. (6.4 mm)] = 1.186 in. (30.12 mm) - $1/2$ in. (12.7 mm) = 0.686 in. (17.4 mm). Taper = $(A_1 - B_1)$ (or $A_2 - B_2$) divided by 2 divided by 0.686 in. (17.4 mm), or $(A_1 - B_1)$ (or $A_2 - B_2$) / 1.372 in. (34.85 mm). (Division by 2 is required to obtain the desired difference in shaft radius between the measuring points.)

A2. MEASUREMENT OF MAIN BEARING CLEARANCE

A2.1 Conduct the main bearing clearance measurements with the crankcase, crankshaft, bearing sets, and measuring tools at room temperature.

A2.2 Use measuring tools having an accuracy of at least 0.003 mm.

A2.3 Install two bearing sets in the crankcase, but do not install the crankshaft. Use either two standard main bearing halves, one standard main bearing half (TEI Part No. 8252) and one undersize main bearing half (TEI Part No. 8252-0.0012 in. U.S.), or two undersize bearing halves. For consistency, when using one standard and one undersize bearing half together, install the standard half in the bearing cap. Torque the bearing block bolts to 81 N·m.

A2.4 Measure the front main bearing vertical diameter at the two points A and B indicated in Fig. A2.1. Each of the points is located in the middle of the respective non-relieved bearing surface. Record the measurements in the appropriate spaces in a table such as Table A2.1.

A2.5 Mount the crankshaft on a workbench with the axis horizontal and with the connecting rod bearing journal vertically upward, simulating the top-dead-center position in the engine.

A2.6 Measure the diameter of the front main journal of the crankshaft at the points A_1 , B_1 , A_2 , and B_2 indicated in Fig. A2.1. Record the measurements in the appropriate spaces in a table such as Table A2.1.

A2.7 Measure the diameters of the rear main bearing and the rear main journal at the points described in A2.4 and A2.6. Record the measurements in Table A2.1.

A2.8 Subtract the diameters to obtain the clearances, as directed in Table A2.1. From the four clearance values thereby determined for each main journal and bearing combination, select the minimum and maximum values, and enter them in the spaces provided in the table.

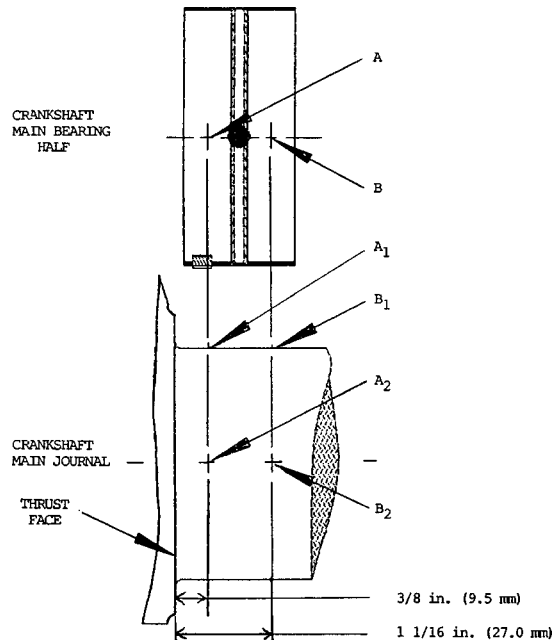

FIG. A2.1 Clearance Measuring Points for Crankshaft Main Bearings

TABLE A2.1 Crankshaft Main Bearing Clearance

Front Main Bearing ^A		Rear Main Bearing ^A	
A _____	B _____	A _____	B _____
A ₁ _____	B ₁ _____	A ₁ _____	B ₁ _____
A ₂ _____	B ₂ _____	A ₂ _____	B ₂ _____
A - A ₁ = _____	B - B ₁ = _____	A - A ₁ = _____	B - B ₁ = _____
A - A ₂ = _____	B - B ₂ = _____	A - A ₂ = _____	B - B ₂ = _____
min _____	max _____	min _____	max _____

^A Diameters A₁ and B₁ are measured at points 90° from A₂ and B₂, respectively.

A2.9 The minimum and maximum main bearing clearances determined in A2.8 must be within the range of 0.051 to 0.076 mm. If they fall outside of this range, either install different bearings, or a different crankshaft, and remeasure the clearances.

A3. THE ASTM TEST MONITORING CENTER CALIBRATION PROGRAM

A3.1 Conducting a Reference Oil Test:

A3.1.1 For those laboratories which choose to utilize the services of the TMC in maintaining calibration of power sections and test stands, full-scale calibration testing shall be conducted at regular intervals. These full-scale tests are conducted using blind, coded reference oils supplied by the TMC. It is a laboratory's responsibility to maintain the calibration in accordance with the test procedure. It is also a laboratory's responsibility to keep the on-site blind reference oil inventory at or above the minimum level specified by the TMC test engineers.

A3.1.2 When laboratory personnel decide to run a reference calibration run, they shall request a blind oil code from the cognizant TMC engineer. Upon completion of the reference oil test using the blind reference oil, the data shall be sent in summary form (use TMC forms) to the TMC by telephone facsimile transmission, or by some other method acceptable to the TMC. The TMC will review the data and contact the laboratory engineer to report the laboratory's calibration status. All reference oil tests, whether aborted, invalidated, or successfully completed, shall be reported to the TMC. Subsequent to sending the data in summary form to the TMC, the laboratory is required to submit to the TMC the written test report specified in the test procedure.

A3.2 *New Laboratories*—Laboratories wishing to become a part of the ASTM Test Monitoring System will be requested to generate both blind and non-blind tests to ensure that the laboratory is using the proper testing techniques. Information concerning fees, laboratory inspection, reagents, testing practices, appropriate committee membership, and rater training can be obtained by contacting the TMC Administrator.²

A3.3 *Introducing New Sequence VIII Reference Oils*—The calibrating reference oils produce various copper-lead bearing weight loss and deposit characteristics. When new reference oils are selected, member laboratories will be requested to conduct their share of tests to enable the TMC to establish the proper industry average and test acceptance limits. The ASTM D02.B0.01 Sequence VIII Surveillance Panel requires a minimum of four tests to be conducted prior to establishing the industry average and test acceptance targets for new reference oils. The TMC estimates that laboratories will be requested to run an average of one contributing test per year for each eight test power sections operated throughout the year.

A3.4 TMC Information Letters:

A3.4.1 Occasionally, it is necessary to change the procedure, and notify the test laboratories of the change, prior to consideration of the change by either Subcommittee D02.B on Automotive Lubricants or Committee D02 on Petroleum Products and Lubricants. In such a case, the TMC will issue an Information Letter. Subsequently, prior to each semiannual Committee D02 meeting, the accumulated Information Letters are balloted by Subcommittee D02.B0. The ballot is reviewed at the Subcommittee D02.B0 meeting, and the actions taken are considered at the following meeting of Committee D02. By this means, the Society due process procedures are applied to these Information Letters.

A3.4.2 Several methods and levels of review are conducted prior to issuing an Information Letter. In the case of an Information Letter concerning a part number change which does not affect test results, the TMC is authorized to issue such a letter. Long-term studies by the Surveillance Panel to improve the test procedure through improved operation and hardware control may result in a recommendation to issue an Information Letter. If obvious procedural items affecting test results need immediate attention, the test sponsor and the TMC will issue an Information Letter and present the background and data to the Surveillance Panel for approval prior to the semiannual Subcommittee D02.B meeting.

A3.4.3 Authority for the issuance of Information Letters was given by the Committee on Technical Committee Operations in 1984, as follows:

“COTCO recognizes that D02 has a unique and complex situation. The use of Information Letters is approved providing each letter contains a disclaimer to the effect that such has not obtained ASTM consensus. These Information Letters shall be moved to such consensus as rapidly as possible.”

A4. MEASUREMENT OF PISTON-TO-SLEEVE CLEARANCE

A4.1 Conduct the piston-to-sleeve clearance measurements with the sleeve, barrel assembly, cylinder head, piston, and measuring tools at room temperature.

A4.2 Use measuring tools having an accuracy of at least 0.003 mm.

A4.3 Install the sleeve into the barrel assembly and torque the cylinder head into place.

A4.4 Measure the sleeve diameter in the transverse (between the valves) direction at the top, middle, and bottom of the sleeve using a bore gage and the bore measurement ladder (Fig. A4.1). Record the measurements in the appropriate spaces in a table such as Table A4.1. Repeat the preceding for the longitudinal (across the valves) direction.

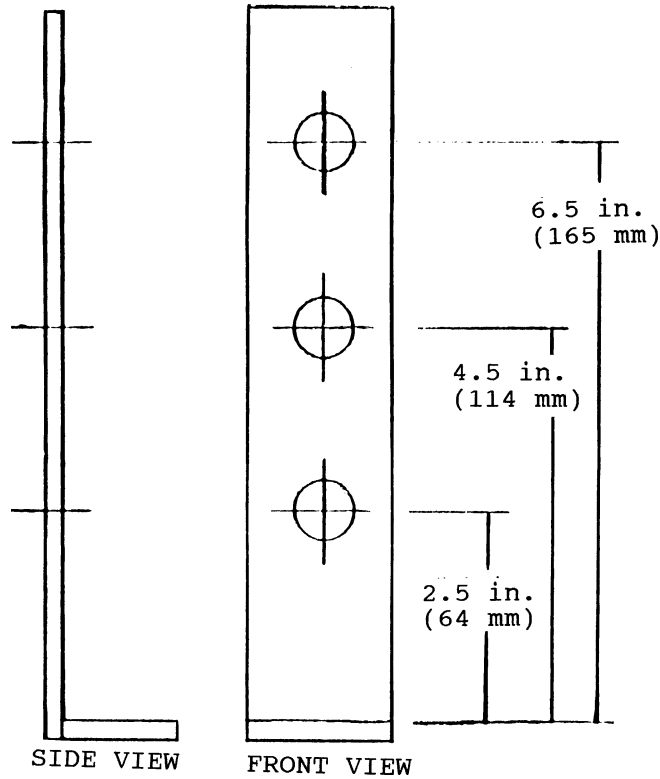

NOTE 1—Overall dimensions are not critical.
 NOTE 2—Make the ladder of brass or aluminum to prevent liner scratching.
 NOTE 3—Holes should be sized as dictated by the bore measurement device which will be used.

FIG. A4.1 Sequence VIII Bore Measurement Ladder

TABLE A4.1 Piston-to-Sleeve Clearance

	Sleeve Diameters, in. (mm)			Taper	
	TOP	MIDDLE	BOTTOM	in.	(mm)
Transverse	a	b	c	g	
Longitudinal	d	e	f	h	
Out-of-Round	i	j	k		
g = (Largest of a, b or c)—(smallest of a, b, or c) h = (Largest of d, e or f)—(smallest of d, e, or f) i = (Largest of a or d)—(smallest of a or d) j = (Largest of b or e)—(smallest of b or e) k = (Largest of c or f)—(smallest of c or f)					
Piston Skirt Diameters					
	Middle	m			
	Bottom	n			
	Taper	p			
	Average	q			
p = (Largest of m or n)—(smallest of m or n) q = (m + n)/2 Piston-to-Sleeve Clearance ((b + c)/2) - q					

A4.5 Heat the piston so that the piston pin can be installed without using any force. Do not exceed 65.5 °C piston temperature. Allow the piston to return to room temperature before measuring. Measure the piston skirt at the middle and bottom of the skirt as indicated in Fig. A4.2. Record the measurements in the appropriate spaces in a table such as Table A4.1.

A4.6 Calculate the sleeve bore diameter to be used for the piston-to-sleeve clearance using the middle and bottom transverse measurements according to Table A4.1.

A4.7 Calculate the sleeve taper according to Table A4.1.

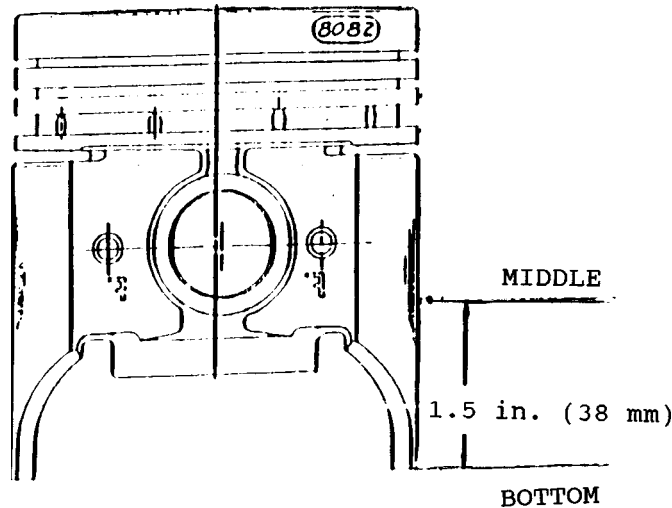

FIG. A4.2 Measurement Points for Sequence VIII Piston

A4.8 Calculate the sleeve out-of-round according to Table A4.1.

A4.9 Calculate the piston diameter to be used for the piston-to-sleeve clearance using the middle and bottom measurements according to Table A4.1.

A4.10 Calculate the piston taper according to Table A4.1.

A4.11 Calculate the piston-to-sleeve clearance according to Table A4.1.

A4.12 The piston-to-sleeve clearance as determined in Table A4.1 shall be within the range of 0.030 to 0.063 mm. If the clearance falls outside of this range, replace the liner, the piston, or both, depending on their relative size.

A5. CONTROL CHART TECHNIQUE FOR A LABORATORY'S SEVERITY ADJUSTMENT (SA)

A5.1 Complete information on the control chart technique is available in the Lubricant Test Monitoring System, available from the ASTM Test Monitoring Center.

A6. NEW LINER HONING PROCEDURE

A6.1 Remove new liner from box and clean protective coating from the liner.

A6.2 Install fret ring and liner into cylinder barrel. Install head gasket and stress plate, torque to specified setting. Fig. A6.1 shows a recommended stress plate.

A6.3 Set cylinder barrel fixture and cylinder barrel into Sunnen CK-10 or CV-616 honing machine^{8,33} and secure. Fig. A6.2 shows a recommended cylinder barrel fixture. The appropriate honing machine setups and honing stone selections are in Table A6.1.

A6.4 Coarse hone liner to within 0.025 mm of determined finish diameter. During coarse honing, rotate and clean stones after every 30 strokes and measure liner between stone rotations for correct taper.

A6.5 After reaching the desired coarse honed liner diameter, allow liner to cool to room temperature and coarse hone to within 0.013 mm of the desired diameter before beginning the finish honing.

A6.6 Complete honing with finishing stone to desired liner diameter and surface finish. The approximate number of strokes will depend on the finishing stone selected.

³³ The sole source of supply of Pencool 2000 the honing machine known to the committee at this time is The Penray Co., Inc., 1801 Estes Ave., Elk Grove, IL 60007; Sunnen Products Co., 7910 Manchester Road, St. Louis, MO 63143.

A6.7 Make the final liner measurements in the actual cylinder barrel of the power section to be used.

A6.8 Use this procedure only for initial new liner honing. For used liners, see 9.4.4.

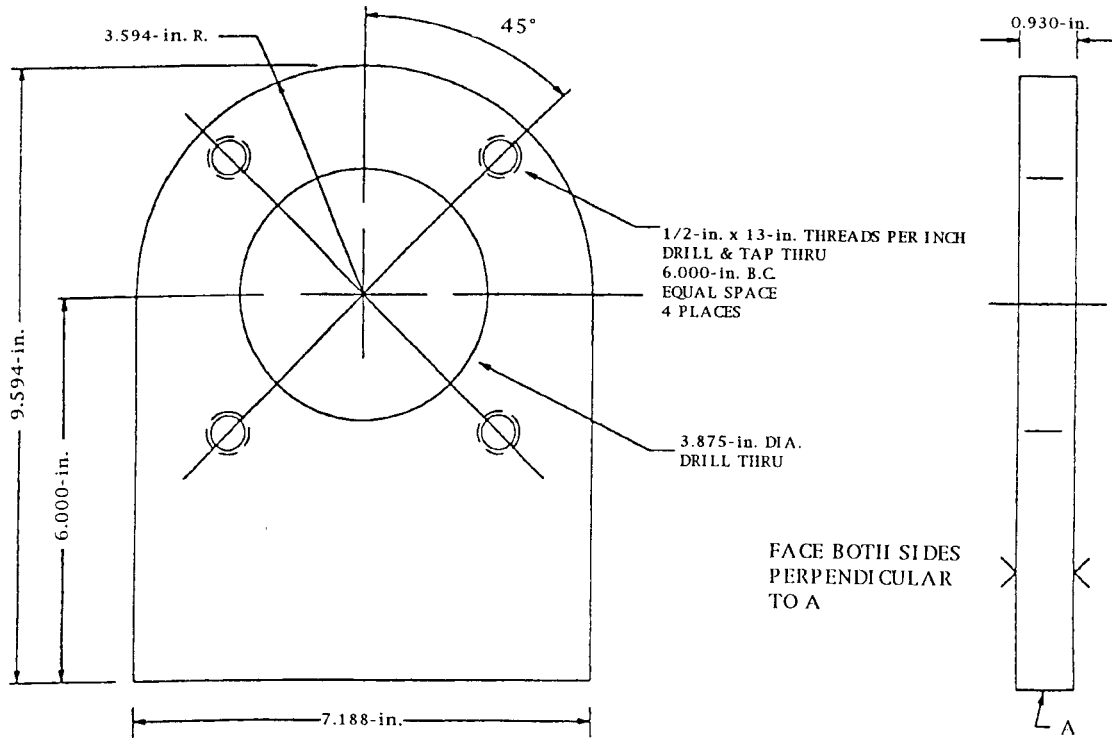

MATERIAL: STEEL PLATE

FIG. A6.1 Stress Plate

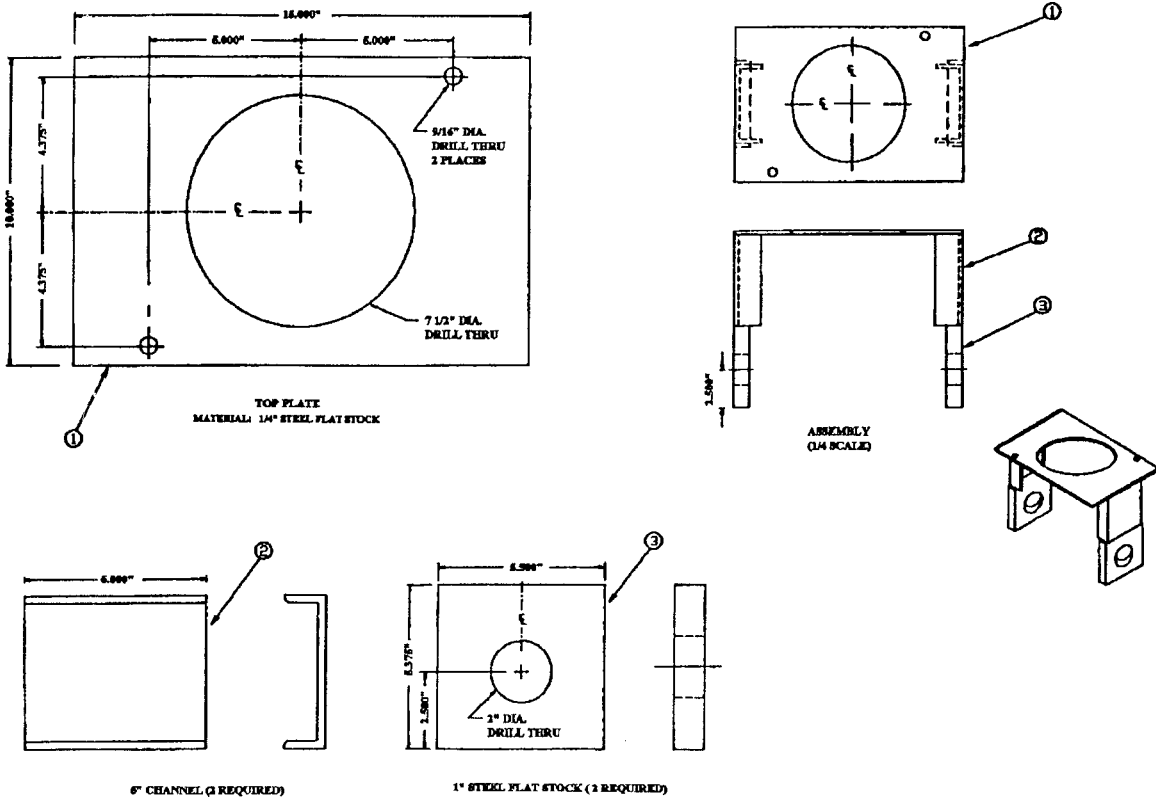

FIG. A6.2 Cylinder Barrel Fixture

TABLE A6.1 Honing Machine Setups and Honing Stone Selection

Parameter	Honing Machine Setup	
	Honing Machine Model No.	
	CK-10	CV-616
Honing oil flow, gpm	2	2
Spindle speed, r/min	155	170
Stroke rate, spm	46	57
Stroke length, in.	7 to 7.25	7 to 7.25
Over-stroke, in.	0.375	0.375
Honing Stones		
Desired Hone	Honing Stone Selection	No. of Strokes (approximate)
Coarse hone	EHU 525	—
Finished hone	JHU 625	10
Finished hone	JHU 820	4

A7. SEQUENCE VIII OIL PRIMING PROCEDURE

- A7.1 Prior to engine starts, confirm that the crankcase has been filled with test oil to the required level.
- A7.2 Disconnect the fuel supply.
- A7.3 Remove the spark plug.
- A7.4 Motor the engine, using the starter, until the oil pressure gage shows a pressure increase.
- A7.5 Cease motoring and reinstall the spark plug.
- A7.6 Start the engine.

A8. ALTERNATIVE CRANKCASE BREATHER CONFIGURATION

A8.1 See Fig. A8.1 for Sequence VIII crankcase breather detail.

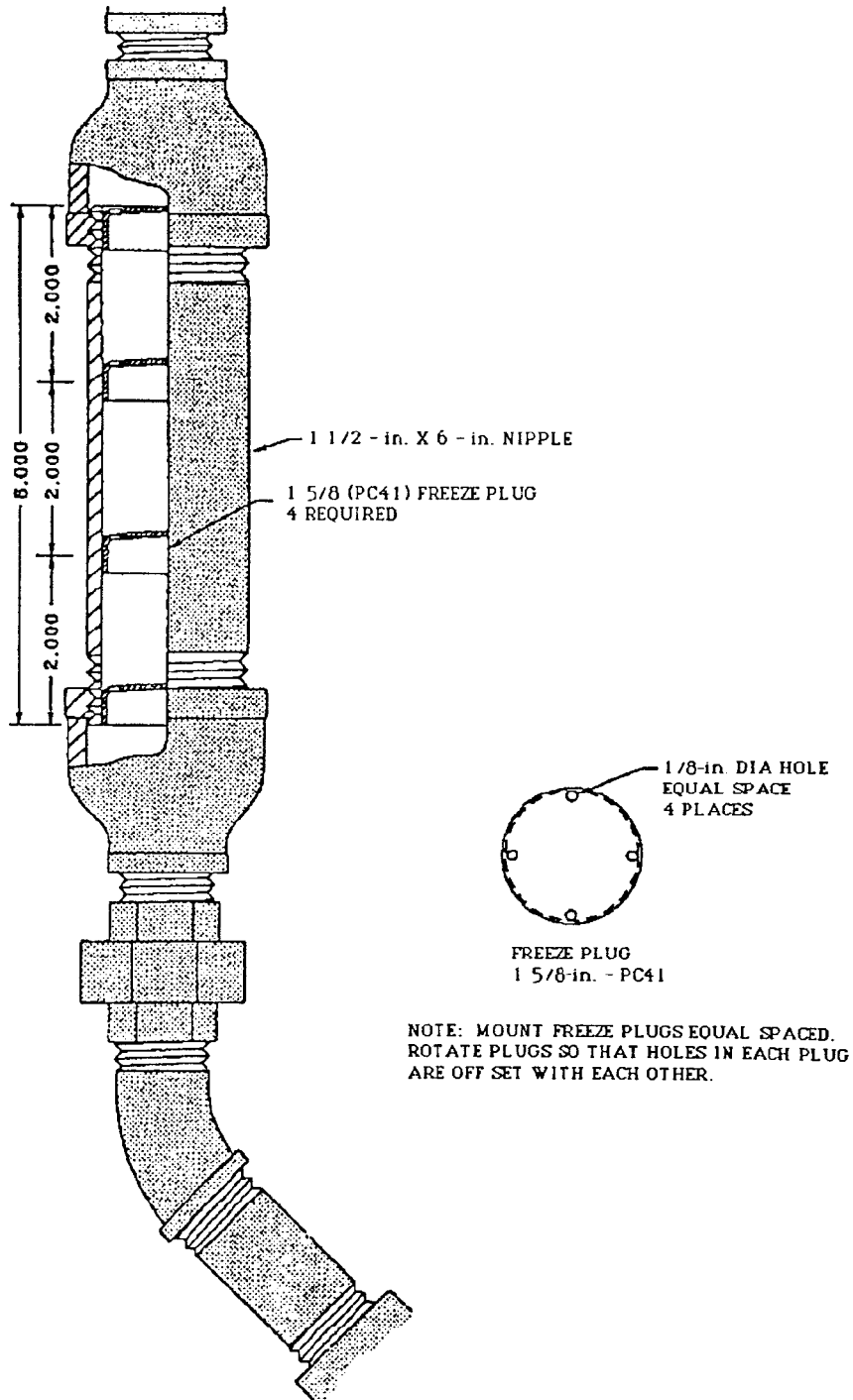

FIG. A8.1 Sequence VIII Crankcase Breather Freeze Plug Detail

A9. CONNECTING ROD BEARING CLEANING PROCEDURE

A9.1 Soak bearings halves in a container of Stoddard Solvent for a minimum of 5 min to remove all traces of oil from both the front and back of the bearing. During the soak period move the bearing halves back and forth in solvent using protective tongs. Exercise care when handling the bearings to prevent nicking or scratching the bearing surface. (Always use latex gloves and protective tongs when handling bearings.)

A9.2 Dip the bearing halves in pentane (**Warning**—Combustible, Health hazard).

A9.3 Place bearing halves into vacuum desiccator for a maximum of 5 min.

A9.4 Remove bearing halves from the vacuum desiccator and inspect for any traces of residue. Repeat A9.1-A9.3 if any residue is evident.

A9.5 Weigh and record to the nearest 0.1 mg, the initial weight of the whole test bearing and the separate weights of the top and bottom halves.

A9.6 Coat the bearing halves with build-up oil.

A9.7 Store the bearing halves in a vacuum desiccator until ready for installation into engine. Start the test break-in within 8 h of removal of the bearing halves from the vacuum desiccator. If the 8 h limit is exceeded, clean, weigh, and install a new set of bearings.

A10. SEQUENCE VIII ELECTRONIC IGNITION CONVERSION PROCEDURE

A10.1 The following parts are needed for the Ford distributor assembly modification:

A10.1.1 Ford distributor assembly,³⁴ Part No. D7EE-12127DA.

A10.1.2 Ford wiring harness,³⁴ Part No. D7JL-12A200A.

A10.1.3 Ford module,³⁴ Part No. D9VZ-12A199A.

A10.1.4 Ford stator assembly,³⁴ Part No. D5TZ-12A122A.

A10.1.5 Ford ignition coil,³⁴ Part No. D5AZ-12029-A.

A10.1.6 GM flat washer,³⁵ Part No. 1984361.

A10.1.7 Nylon flat washer, Part No. 98160-0.62.^{8, 36}

A10.1.8 Fabricated distributor shaft.^{8, 37}

A10.1.9 Fabricated hold down assembly.^{8, 37}

A10.2 Disassemble the Ford distributor assembly, Part No. D7EE-12127DA. Save all parts as most will be needed for the modification.

A10.3 Remove the vacuum advance mounting assembly from the Ford distributor housing as shown in Fig. A10.1.

A10.4 Modify the lower section of the Ford distributor housing as shown in Fig. A10.2.

A10.5 Remove three of the four existing poles from the armature of the Ford distributor assembly as shown in Fig. A10.3. Reference the grooves for the roll pin to remove the correct poles.

A10.6 Remove the fibre seat from the lower plate assembly of the Ford distributor and enlarge the hole to 4.76 mm as shown in Fig. A10.4.

A10.7 Remove the vacuum advance bracket from the upper stator assembly plate of the Ford distributor shown in Fig. A10.5.

³⁴ The sole source of supply of Haltermann Products KA24E Test Fuel known to the committee at this time is Haltermann Products, Ten Lamar, Ste 1800, Houston, TX 77002.

³⁴ This apparatus may be purchased from any Ford dealership.

³⁵ The document, "Lubricant Test Monitoring System," is available

³⁵ This apparatus may be purchased from the TMC; any General Motors dealership.

³⁶ The sole source of supply of the honing machine flat washer known to the committee at this time is ~~Sunnen Products~~ Accurate Screw Machine Co., 7910 Manchester Road, St. Louis, MO 63143-19 Baltimore St., Nutley, NJ 07110.

³⁷ The sole source of supply of the apparatus may be purchased from any Ford dealership; known to the committee at this time is Texas Tool Makers, Inc., San Antonio, TX 78216.

CUT OFF VACUUM ADVANCE
MOUNTING ASSEMBLY

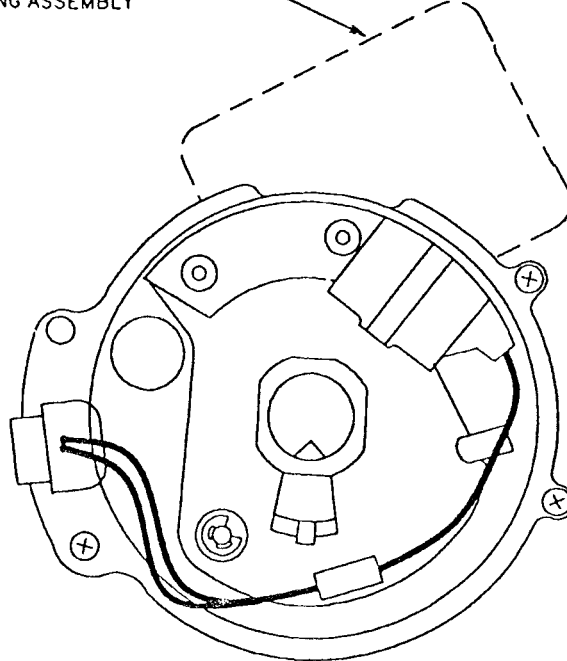
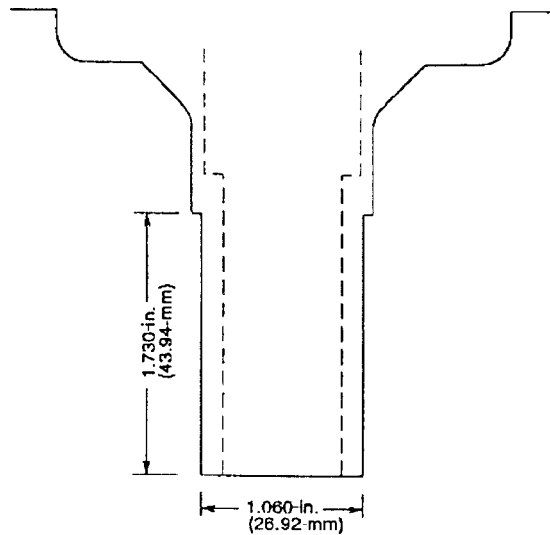

FIG. A10.1 Modified Ford Distributor Housing



MODIFY TO SPECIFICATION SHOWN

FIG. A10.2 Modified Ford Distributor Housing

A10.8 Center and mount the upper stator assembly plate onto the lower plate. Drill a 4.76-mm hole through the upper plate aligning the hole with 4.76-mm hole in the lower plate as shown in Fig. A10.5.

A10.9 Attach the upper and lower plates using a 4.76-mm rivet as shown in Fig. A10.5. Use a spacer of approximately 2.16-mm between the two plates.

A10.10 Cut the drive gear from the upper collar of the Ford distributor assembly. Fig. A10.6 shows the dimensions of the collar after the drive gear has been removed.

A10.11 Fabricate the distributor shaft as shown in Fig. A10.7. The shaft may also be purchased from Texas Tool Makers, Inc.^{8,37}

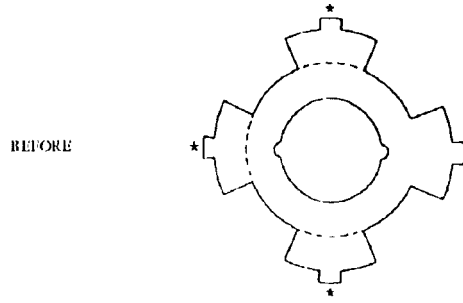

* CUT OFF THESE 3 POLES

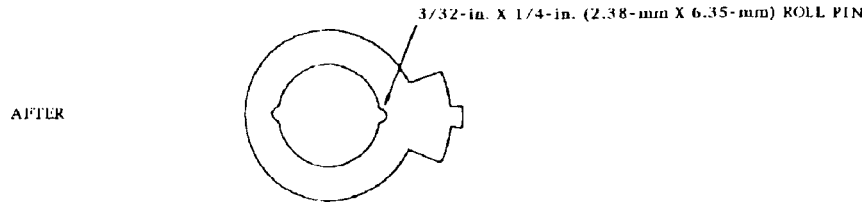

FIG. A10.3 Modified Ford Distributor-Armature

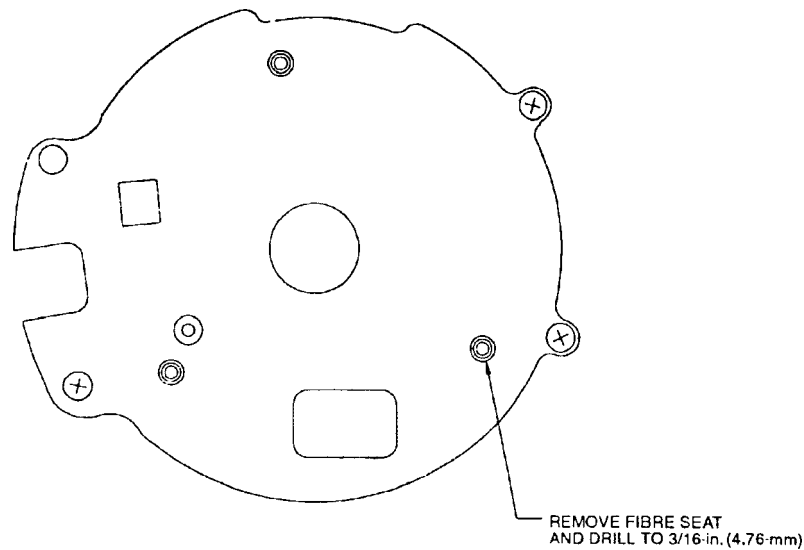
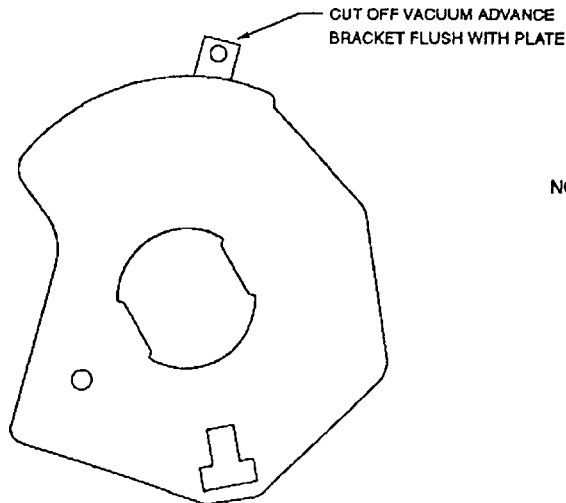

FIG. A10.4 Modified Ford Distributor-Lower Plate Assembly

A10.12 Fabricate the hold down assembly as shown in Figs. A10.8 and A10.9. The hold down assembly may also be purchased from Texas Tool Makers, Inc.

A10.13 Assemble the modified distributor as shown in Fig. A10.10.



NOTE:
MOUNT STATOR ASSEMBLY AND CENTER ON LOWER PLATE, DRILL 3/16-in. (4.76-mm) HOLE IN STATOR ASSEMBLY TO MATCH LOWER PLATE. ATTACH STATOR TO LOWER PLATE USING 3/16-in. x 1/2-in. (4.76-mm x 12.7-mm) RIVET AND .085-in. (2.16-mm) SPACER BETWEEN STATOR AND LOWER PLATE.

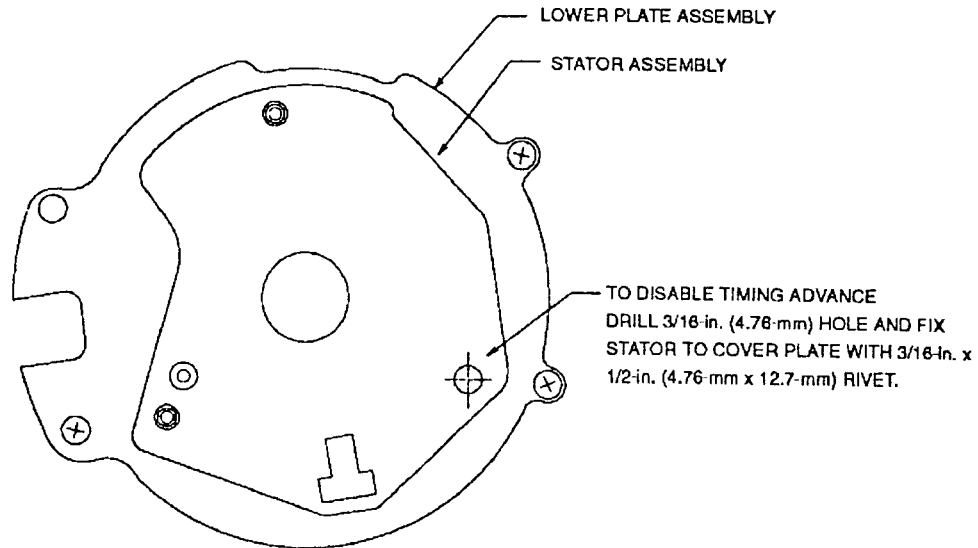

FIG. A10.5 Modified Ford Distributor-Stator Assembly

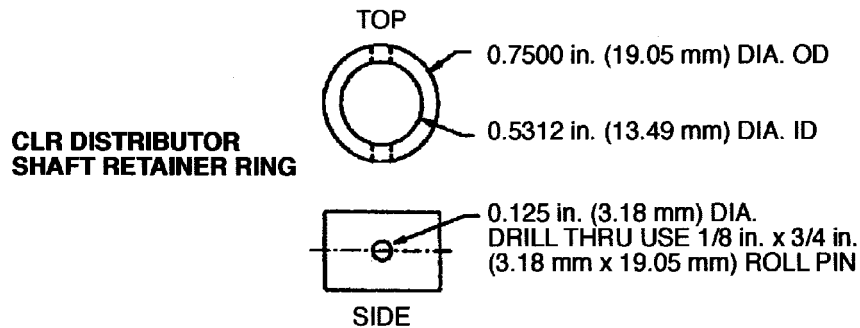

FIG. A10.6

FIG. A10.6 Modified Ford Distributor-Upper Collar

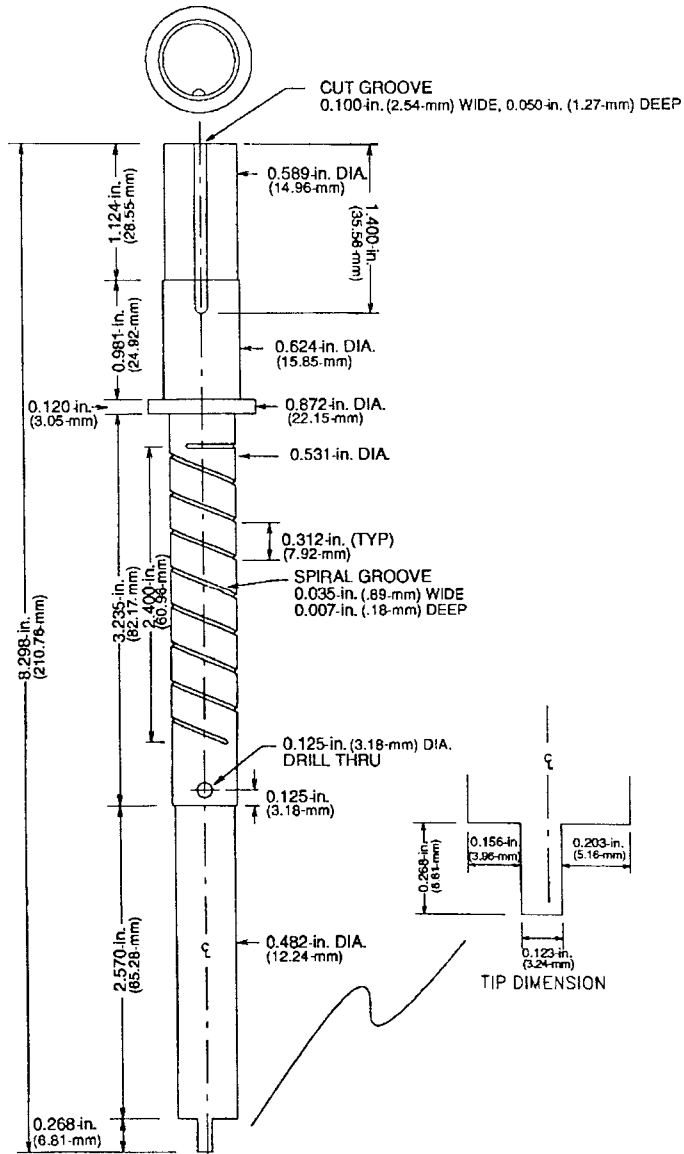
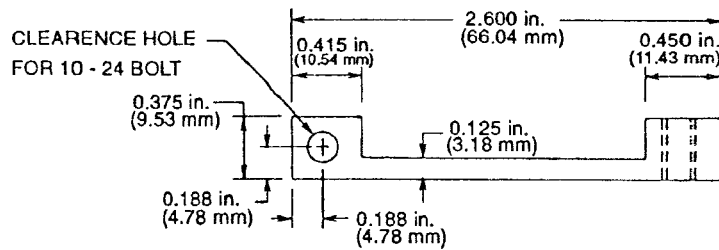
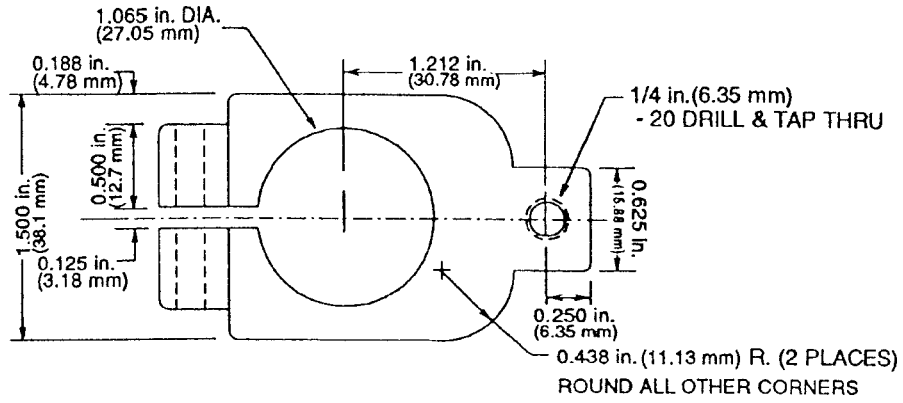
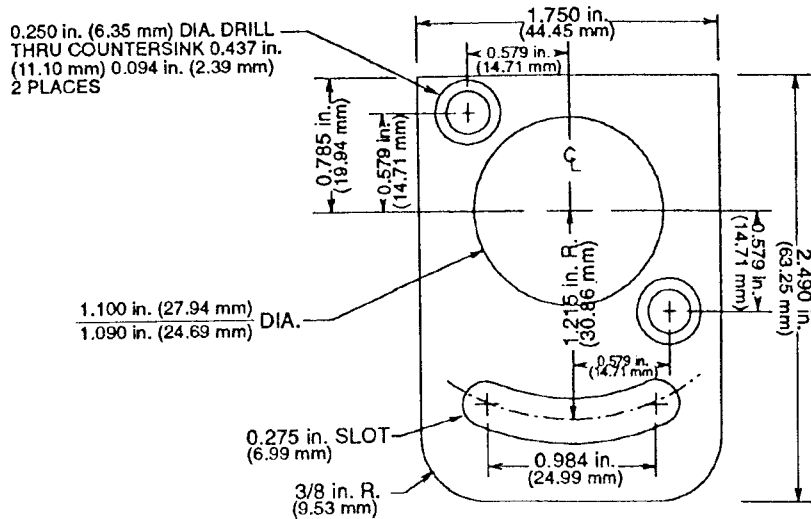

FIG. A10.7 Fabricated Distributor Shaft



NOTE—Material: 3/8-in. 1 1/2-in. × 2 5/8-in. (9.53-mm, 38.1-mm × 66.68-mm) plate.

FIG. A10.8 Fabricated Hold Down Clamp



NOTE—Material: 1/8-in. (3.16-mm) plate.

FIG. A10.9 Fabricated Hold Down Clamp

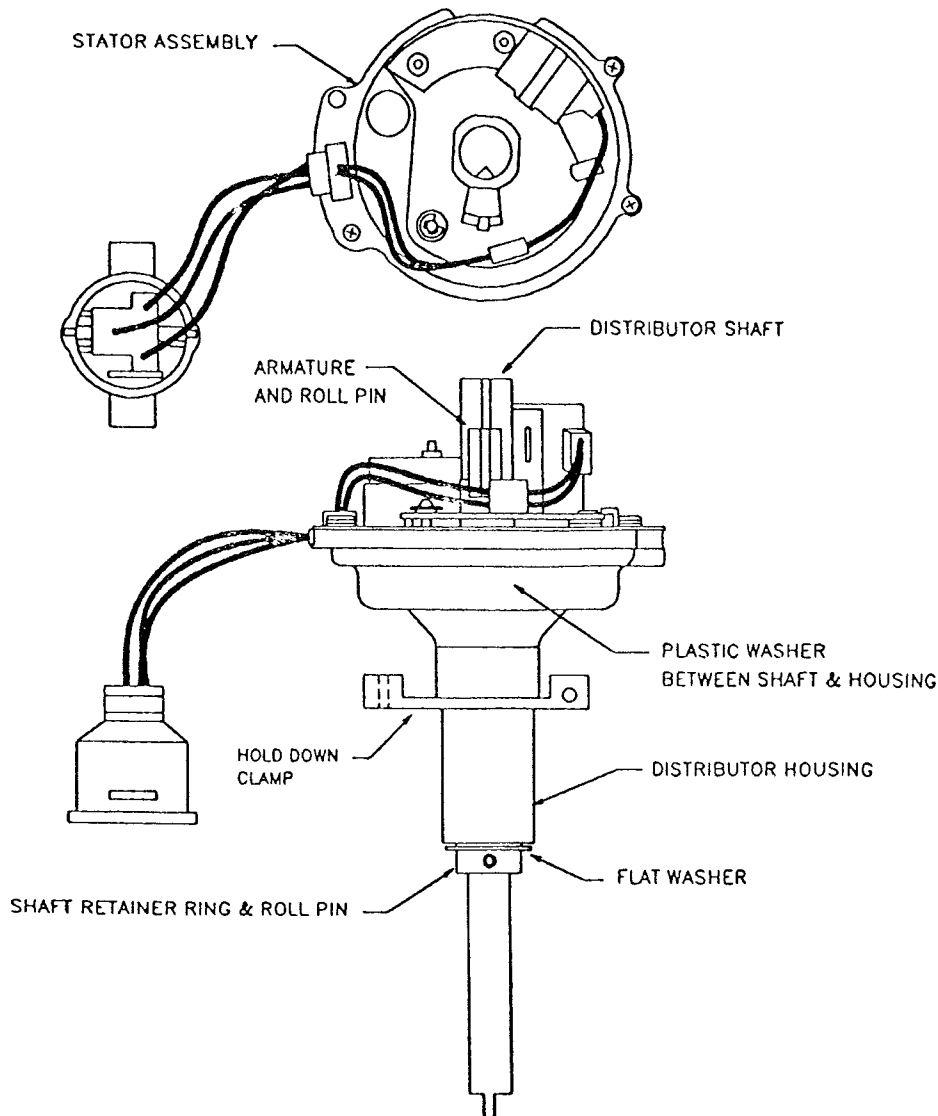

FIG. A10.10 Modified Ford Distributor Assembly

A11. SYSTEM RESPONSE PROCEDURE

A11.1 *Temperatures*—Remove the thermocouples from the engine locations as specified in 6.3.5. Allow the thermocouples to stabilize at ambient conditions, then insert them into a bucket of ice water. Record the time it takes the thermocouple to reach 63 % of its final value.

A11.2 *Pressures and Vacuums*—First perform a leak-down on the measurement system to ensure there are no air leaks by following the test below:

A11.2.1 Disconnect the sensor lines at the engine locations as specified in 6.3.4. Connect an air line to the sensor line and pressurize the line slightly above the specified range required (test specification). Isolate the air pressure in the sensor line and remove the source from the sensor line. If the system leaks down, repair the leak before proceeding.

A11.2.2 After completion of the leak down step, determine the system response. Connect an air line to the sensor line and pressurize the system to the specified mean range. Let the system stabilize, then quickly release pressure, record the time to reach 63 % of its final value.

A11.2.3 For vacuums, follow the above procedure replacing air pressure with vacuum.

A11.3 *Fuel Flow*:

A11.3.1 *Flow Meters*— Establish a steady flow at the normal test specified mean range. Let the system stabilize. Shut off the flow and record the time required to reach 63 % of the final value.

A11.3.2 *Fuel Weight Scales*—Follow the normal procedure for measuring fuel usage. This value shall represent the total time it takes to measure the fuel flow (from the time the engine begins to run from the beaker until the scales trips).

A11.4 *Speed*—Using a frequency counter, inject a frequency so that the system readout stabilizes at the test specified mean value. Use a frequency device to determine the engine speed. Disconnect the frequency device, measure and record the time required to reach 63 % of the final value.

A11.5 *Load*—Place a weight on a measurement device and let the reading stabilize. Quickly remove the weight, measure and record the time required to reach 63 % of the final value. Weights used shall represent the normal readout value. For manual measurements, a stopwatch with 0.1 second increments is required.

A12. AIR-FUEL RATIO MEASUREMENT

A12.1 Correct carbon monoxide (CO) or carbon dioxide (CO₂) measurements to an oxygen-free basis, using formulae Eq A12.1 and A12.2 prior to determining air-fuel ratio. Use the corrected CO or CO₂ value and Table A12.1 to determine air-fuel ratio.

$$\frac{\text{Observed Percent CO} \times 100}{100 - 5 (\text{Observed \% O}_2)} = \text{Corrected CO} \quad (\text{A12.1})$$

$$\frac{\text{Observed Percent CO}_2 \times 100}{100 - 5 (\text{Observed \% O}_2)} = \text{Corrected CO}_2 \quad (\text{A12.2})$$

TABLE A12.1 Air-Fuel Ratio Versus (O₂, CO and CO₂)

NOTE—Theoretical Combustion, KA24E Green Fuel Batch 9910652.

Air-Fuel Ratio	O ₂	CO	CO ₂	Air-Fuel Ratio	O ₂	CO	CO ₂
7.298	0	19.793	2.97	14.595	0	0	15.215
7.59	0	19.008	3.383	14.887	0.44	0	14.896
7.881	0	18.218	3.807	15.179	0.862	0	14.589
8.173	0	17.424	4.241	15.471	1.266	0	14.295
8.465	0	16.626	4.686	15.763	1.655	0	14.013
8.757	0	15.823	5.142	16.055	2.029	0	13.741
9.049	0	15.017	5.607	16.347	2.388	0	13.48
9.341	0	14.206	6.081	16.639	2.735	0	13.229
9.633	0	13.393	6.564	16.931	3.068	0	12.987
9.925	0	12.577	7.055	17.223	3.389	0	12.753
10.217	0	11.76	7.553	17.514	3.7	0	12.528
10.509	0	10.943	8.058	17.806	3.999	0	12.31
10.801	0	10.126	8.567	18.096	4.288	0	12.1
11.092	0	9.31	9.081	18.39	4.567	0	11.898
11.384	0	8.497	9.598	18.682	4.838	0	11.701
11.676	0	7.687	10.116	18.974	5.099	0	11.511
11.968	0	6.883	10.636	19.266	5.352	0	11.328
12.26	0	6.084	11.156	19.558	5.597	0	11.149
12.552	0	5.291	11.675	19.85	5.835	0	10.977
12.844	0	4.507	12.193	20.142	6.065	0	10.81
13.136	0	3.731	12.707	20.433	6.288	0	10.647
13.428	0	2.964	13.218	20.725	6.505	0	10.49
13.72	0	2.207	13.725	21.017	6.716	0	10.337
14.012	0	1.46	14.227	21.309	6.92	0	10.189
14.303	0	0.724	14.724	21.601	7.119	0	10.044
				21.893	7.312	0	9.904

A13. LEAD DECONTAMINATION PARTS/PROCEDURE

A13.1 Use the following procedure for lead decontamination of CLR test engine that previously ran using a lead base fuel.

A13.1.1 *Parts to be Cleaned:*

A13.1.1.1 Inside of crankcase.

A13.1.1.2 Bottom of cylinder jug assembly.

A13.1.1.3 Cylinder head assembly.

A13.1.1.4 Inside of intake manifold.

A13.1.1.5 All crankcase cover plates (front and both sides).

A13.1.1.6 Oil pan.

A13.1.1.7 Rocker cover.

A13.1.1.8 Oil heater and canister.

A13.1.1.9 Blowby tube assembly.

A13.1.1.10 Camshaft and gear.

A13.1.1.11 Crankshaft and gear.

A13.1.1.12 Oil pump assembly.

A13.1.1.13 Any other parts that may have come in contact with lead.

A13.2 *Cleaning Procedure:*

A13.2.1 Prior to acid cleaning of all parts, remove all sludge and varnish deposits.

A13.2.2 Using a lint free towel or parts washing brush apply the 1:3 mixture of hydrochloric acid and deionized water to all parts.

A13.2.3 Apply a 1:8 mixture of baking soda and water after approximately 60 s.

A13.2.4 Repeat A13.2.2 and A13.2.3.

A13.2.5 Apply build-up oil to ensure that rust does not form.

A13.2.6 Clean engine parts according to either procedure in 9.4.3.

A13.3 *Future Cleaning after Lead Decontamination:*

A13.3.1 Once the engine parts have been decontaminated, handle them only in a lead-free environment. If the parts come into contact with a lead contaminated cleaning material or are used in an engine running on a fuel containing > 0.01 g/U.S.gal of lead they shall lose their status as cleaned parts. They shall only regain their clean status by undergoing another lead decontamination cleaning (A13.2.1 through A13.2.6).

A14. STAY-IN-GRADE OIL ANALYSIS PROCEDURE

A14.1 Determine the ability of the test oil (multiviscosity oils only) to stay in grade by measuring the shear stability using the following method.

A14.1.1 Weigh 25 g of the test oil sample taken at 10 h into a 50-mL three-necked round-bottom flask equipped with a thermometer, gas inlet tube, and distillation side arm.

A14.1.2 Heat the sample at 120 ± 5 °C in a vacuum of 100 mm Hg with a nitrogen sparge for 1 h. Do not consider warm-up time to meet the specified temperature as part of the 1 h.

A14.1.2.1 Place the gas inlet tube beneath the surface of the oil sample in the flask so that the nitrogen sparge stirs the sample during the heating operation.

A14.1.2.2 Begin the 1-h time clock when the oil sample reaches 115°C.

A14.1.3 Filter the stripped sample through a 0.5 µm filter pad.

A14.1.4 Determine the kinematic viscosity at 100 °C of the filtered sample using Test Method D 445.

A15. CRANKSHAFT REAR SEAL CONDITIONING PROCEDURE

A15.1 Procedure for Preparation of Rear Oil Seal Crankshaft Surface:

NOTE A15.1—This procedure aids in preventing rear seal related oil leaks.

A15.1.1 Prepare a 25.4 mm wide and 600 mm long section of 120 grit abrasive paper.

A15.1.2 Looking from the back of the crankshaft forward, move the paper across the seal surface in a counter-clockwise direction with a front to back motion using a spiraling motion that produces scratches with an approximate 5 to 10° helix angle. Between 5 to 10 strokes shall produce the proper surface finish.

A15.1.3 Clean the crankshaft (see 9.4.7.10) to ensure that no abrasive remains on it.

~~**A16. SEQUENCE VIII ENGINE EVALUATION**~~

~~**A16. REPORT FORMS AND DATA DICTIONARY**~~

~~A16.1 Figs. A16.1-A16.10 are examples of Download the actual report forms.~~

A17. DATA DICTIONARY

A17.1 Fig. A17.1 is the Data Dictionary forms and Fig. A17.2 is data dictionary separately from the R ASTM Test Monitoring Center web page at <ftp://ftp.astmtmc.cmu.edu/datadict/viii/>; or obtain them in hardcopy format from the TMC.²

<u>Title/Validity Declaration Page</u>	Form 1
<u>Table of Contents</u>	Form 2
<u>Summary of Test Method</u>	Form 3
<u>Test Results</u>	Form 4
<u>Operational Summary</u>	Form 5
<u>Parts-Met-Parts-Listing</u>	Form 6
<u>Parts Measurement and Critical Parts Listing</u>	Form 6
<u>Downtime Occurences and S-Other Comments</u>	Form 7
<u>Downtime Occurences and Other Comments</u>	Form 7
<u>Occurences</u>	Form 8
<u>Operational Outliers Occurrences</u>	Form 8
<u>Devificaters</u>	Form 9
<u>Deviations of Operational Parameters</u>	Form 9
<u>Data Acquisitions.tem-Details</u>	Form 10
<u>Data Acquisition System Details</u>	Form 10

APPENDIXES

(Nonmandatory Information)

X1. ROLE OF THE ASTM TEST MONITORING CENTER AND THE CALIBRATION PROGRAM

X1.1 The TMC, a nonprofit organization located in Pittsburgh, Pennsylvania, is staffed to administer engineering studies; conduct engineering laboratory visits; conduct statistical analysis of reference data; store, blend, and ship reference oils; and provide the associated administrative functions to maintain the referencing calibration program for various tests as directed by Subcommittee D02.B and the Test Monitoring Board. The TMC maintains close communication with the test sponsors, the test developers, the surveillance panels, and the testing laboratories.

X1.2 The TMC operates in accordance with the ASTM Charter, the ASTM Bylaws, the Regulations Governing ASTM Technical Committees, the Bylaws Governing ASTM Committee D02, and the Rules and Regulations governing the ASTM Test Monitoring System. The management of the system is vested in the Test Monitoring Board elected by Subcommittee D02.B.

X1.3 The TMC operating income is obtained from fees for each reference oil test conducted and each reference oil issued. Fee schedules are reviewed and established by Subcommittee D02.B.

X2. SUGGESTED METHOD FOR SALVAGING CAMSHAFT BEARING JOURNALS

X2.1 The following method is suggested for salvaging out-of-limit camshaft journals, or for decreasing the camshaft journal clearance.

X2.1.1 Build up material on the journals by flame spraying. The following material has proven successful:

Met-Caloy No. 2^{12,41}(mass %)
<u>Met-Caloy No. 2^{8,38}(mass %)</u>
carbon, 0.32 %
silicon, 0.50 %
magnesium, 0.50 %
phosphorus, 0.02 %
sulfur, 0.02 %
chromium, 13.5 %
iron, balance

X2.1.1.1 Apply a layer of Met-Caloy No. 2, 0.25 mm maximum thickness, directly to the worn surface. Grind the journal to the desired size.

X2.1.1.2 If a build-up of more than 0.25 mm thickness is required, first grind the surface undersize and apply a spray of bond material to within 0.05 mm undersize of the final diameter. Cover the remaining surface with Met-Caloy No. 2 and grind to the desired size.

³⁸ The sole source of supply of the apparatus known to the committee at this time is Met-Caloy No. 2 can be purchased obtained from any General Motors dealership. Metco, Inc., 1101 Prospect Ave., Westbury, NY 11590.

X3. DATA LOG SHEETS

X3.1 Examples of suitable log sheets are shown in Figs. X3.1 and X3.2.

ASTM International takes no position respecting the validity of any patent rights asserted in connection with any item mentioned in this standard. Users of this standard are expressly advised that determination of the validity of any such patent rights, and the risk of infringement of such rights, are entirely their own responsibility.

This standard is subject to revision at any time by the responsible technical committee and must be reviewed every five years and if not revised, either reapproved or withdrawn. Your comments are invited either for revision of this standard or for additional standards and should be addressed to ASTM International Headquarters. Your comments will receive careful consideration at a meeting of the responsible technical committee, which you may attend. If you feel that your comments have not received a fair hearing you should make your views known to the ASTM Committee on Standards, at the address shown below.

This standard is copyrighted by ASTM International, 100 Barr Harbor Drive, PO Box C700, West Conshohocken, PA 19428-2959, United States. Individual reprints (single or multiple copies) of this standard may be obtained by contacting ASTM at the above address or at 610-832-9585 (phone), 610-832-9555 (fax), or service@astm.org (e-mail); or through the ASTM website (www.astm.org).

"LABORATORY NAME"
SEQUENCE VIII TEST DATA LOG SHEET

RUN NUMBER _____
(Stand-Engine-Runs Since Reference-Total Runs)

ENGINE NUMBER _____

STAND NUMBER _____

OIL CODE _____

HEADER	RUN-IN					FLUSH
	OBSERVER					
	DATE					
	TIME					
	TOTAL HOURS ON "RUN-IN" OR "FLUSH"	1	2	3	4	
TEST PARAMETER						
ENGINE	ENGINE SPEED (Specified, ± 25 r/min)	1500	2000	2500	3150	3150
	ENGINE SPEED (Actual, r/min)					
	ENGINE OUTPUT (Specified, ± 150 W)	1500	3000	3700	3700	3730
	ENGINE OUTPUT (Actual, W)					
TEMPERATURES	OIL GALLERY (107.0 °C MAX)					
	COOLANT OUTLET (93.5 °C MAX)					
	**COOLANT INLET (Record, °C)					
	**COOLANT DIFFERENTIAL (5.6 ± 1 °C)					
	**CARBURETOR INTAKE AIR (Record, °C)					
	**EXHAUST (Record, °C)					
PRESSURES	OIL GALLERY (280 ± 10 kPa)					
	**CRANKCASE VACUUM (.500 ± .120 kPa)					
	**EXHAUST BACK PRESSURE (0 to 3.4 kPa)					
	**INTAKE VACUUM (Record, kPa)					
FLOWS	**FUEL (2.15 ± 0.11 kg/h @ 3150 r/min)					
	**CARBURETOR AIR (Record, kg/h)					
	**AIR FUEL RATIO (13.43 ± 0.5)					
	**CRANKCASE OFF-GAS (850 ± 28 SLH)					
	**ROCKER AIR (Record, SLH)					
	**BLOWBY (approx. 280 ± 60 SLH)					
MISC	IGNITION ADVANCE (Specified, ± 1° Before Top Dead Center, BTDC)	25	25	35	35	35
	IGNITION ADVANCE (Actual, BTDC)					
	OIL HEATER POWER (W)	Oil Heater not in Oil Circuit.				OFF

** Recommended but Not Required.

FIG. X3.1 Run-in and Flush Data Log Sheet

Required Oil Charge and Sample Volumes

Run-in Oil Charge:	2840 mL
Flush Oil Charge:	1660 mL
Test Oil Charge:	1660 mL
Purge Sample:	60 mL
Oil Sample:	180 mL
New Oil Additions	240 mL



		Column No. ---->	1	2	3	4	5	6	7	8	9	10
HEADER	OBSERVER											
	DATE											
	TIME											
	TOTAL HOURS ON STEADY-STATE TEST											
TEST PARAMETER												
ENG	ENGINE SPEED	(3150 ± 25 r/min)										
	ENGINE OUTPUT	(Record, W)										
TEMPERATURES	OIL GALLERY	(135 ± 1°C: SAE 5W, 10W oils) (143.5 ± 1°C: SAE 20, 30, 40, 50 & multigrade oils)										
	COOLANT OUTLET	(93.5 ± 1°C)										
	COOLANT INLET	(Record, °C)										
	COOLANT DIFFERENTIAL	(5.6 ± 1 °C)										
	CARBURETOR INTAKE AIR	(Record, °C)										
PRESSURES	OIL GALLERY	(280 ± 10 kPa)										
	CRANKCASE VACUUM	(.500 ± .120 Pa)										
	EXHAUST BACK PRESSURE	(0 to 3.4 kPa)										
	INTAKE VACUUM	(Record, kPa)										
FLOWS	FUEL	(2.15 ± 0.11 kg/h)										
	*CARBURETOR AIR	(approx. 30.2 kg/h)										
	*AIR FUEL RATIO	(13.43 ± 0.5)										
	CRANKCASE OFF-GAS	(850 ± 28 SLH)										
	ROCKER AIR	(Record, SLH)										
	BLOWBY	(approx. 280 ± 60 SLH)										
MISC	*IGNITION ADVANCE	(35 ± 1° Before Top Dead Center, BTDC)										
	OIL HEATER POWER	(Optional, record if used for for oil temp control, W)										

* Required during Hours: 1, 10, 20 and 30.

FIG. X3.2 Test Data Log Sheet