



Standard Test Method for Cummins M11 High Soot Test¹

This standard is issued under the fixed designation D 6838; the number immediately following the designation indicates the year of original adoption or, in the case of revision, the year of last revision. A number in parentheses indicates the year of last reapproval. A superscript epsilon (ϵ) indicates an editorial change since the last revision or reapproval.

1. Scope

1.1 This test method is commonly referred to as the Cummins M11 High Soot Test (HST). The test method defines a heavy-duty diesel engine test procedure conducted under high soot conditions to evaluate oil performance with regard to valve train wear, sludge deposits, and oil filter plugging.²

1.2 The values stated in SI units are to be regarded as the standard. The values given in parenthesis are for information only.

1.3 *This standard does not purport to address all of the safety concerns, if any, associated with its use. It is the responsibility of the user of this standard to establish appropriate safety and health practices and determine the applicability of regulatory limitations prior to use.* See Annex A1 for general safety precautions.

1.4 *Table of Contents:*

Subject	Section
Scope	1
Referenced Documents	2
Terminology	3
Summary of Test Method	4
Significance and Use	5
Apparatus	6
Test Engine Configuration	6.1
Test Engine	6.1.1
Oil Heat Exchanger, Adapter Blocks, and Block Off Plate	6.1.2
Oil Pan Modification	6.1.3
Engine Control Module	6.1.4
Air Compressor and Fuel Pump	6.1.5
Test Stand Configuration	6.2
Engine Mounting	6.2.1
Intake Air System	6.2.2
Aftercooler	6.2.3
Exhaust System	6.2.4
Fuel Supply	6.2.5
Coolant System	6.2.6
Pressurized Oil Fill System	6.2.7
External Oil System	6.2.8
Crankcase Aspiration	6.2.9
Blowby Rate	6.2.10
System Time Responses	6.3
Oil Sample Containers	6.4
Mass Balance	6.5
Engine and Cleaning Fluids	7
Test Oil	7.1
Test Fuel	7.2
Engine Coolant	7.3
Solvent	7.4
Preparation of Apparatus	8
Cleaning of Parts	8.1
Crosshead Cleaning and Measurement	8.1.6
Rod Bearing Cleaning and Measurement	8.1.7
Engine Assembly	8.2
General	8.2.1
Parts Reuse and Replacement	8.2.2
Build-Up Oil	8.2.3

¹ This test method is under the jurisdiction of ASTM Committee D02 on Petroleum Products and Lubricants and is the direct responsibility of Subcommittee D02.08 on Automotive Lubricants.

Current edition approved Nov. 10, 2002. Published June 2004. Originally approved in 2002. Last previous edition approved in 2002 as D 6838-02.

² The ASTM Test Monitoring Center (TMC) will update changes in this test method by means of Information Letters. This edition incorporates revisions in all Information Letters through No. 03-1. Information letters may be obtained from the ASTM Test Monitoring Center, 6555 Penn Ave., Pittsburgh, PA 15206-4489, Attention: Administrator.



Subject	Section
Coolant Thermostat	8.2.4
Oil Thermostat	8.2.5
Fuel Injectors	8.2.6
New Parts	8.2.7
Operational Measurements	8.3
Units and Formats	8.3.1
Instrumentation Calibration	8.3.2
Temperatures	8.3.3
Pressures	8.3.4
Flow Rate	8.3.5
Engine/Stand Calibration and Non-Reference	9
Oil Tests	
General	9.1
Calibration Configuration	9.2
New Test Stand	9.3
Engine/Stand Calibration Period	9.4
Change of Calibration Configuration	9.5
Stand Modification and Calibration Status	9.6
Test Numbering System	9.7
Reference Oil Test Acceptance	9.8
Unacceptable Reference Oil Test	9.9
Reference Oil Accountability	9.10
Non-Reference Oil Tests	9.11
Test Procedure	10
Engine Installation and Stand Connections	10.1
Coolant System Fill	10.2
Oil Fill for Break-in	10.3
Fuel Samples	10.4
Engine Warm-up	10.5
Engine Break-in	10.6
Shutdown and Maintenance	10.7
200-h Test Procedure	10.8
Oil Fill for Test	10.8.2
Zero-h Oil Sample	10.8.3.1
Operating Conditions	10.8.4
Injection Timing Change	10.8.5
%Soot Validity	10.8.6
Test Timer	10.8.7
Operational Data Acquisition	10.8.8
Oil Purge, Sample and Addition	10.8.9
Full and Drain Weight	10.8.9.2
End of Test (EOT)	10.9
Engine Disassembly	10.9.4
Calculations, Ratings and Test Validity	11
Crosshead Mass Loss	11.1
Rod Bearing Mass Loss	11.2
Sludge Ratings	11.3
Piston Ratings	11.4
Oil Filter Plugging	11.5
Oil Analyses	11.6
Oil Consumption	11.7
Fuel Analyses	11.8
Ring Mass Loss	11.9
Assessment of Operational Validity	11.10
Assessment of Test Interpretability	11.11
Test Report	12
Precision and Bias	13
Keywords	14
Annexes	
Safety Precautions	Annex A1
Mandatory Supplier List	Annex A2
Engine Build Parts Kit	Annex A3
Sensor Locations and Special Hardware	Annex A4
External Oil System	Annex A5
Fuel Specification	Annex A6
Cummins Service Publications	Annex A7
Specified Units and Formats	Annex A8
Report Forms	Annex A9
Sludge Rating Forms	Annex A10
Piston Rating Locations	Annex A11
Oil Analyses	Annex A12
Oil Filter Plugging	Annex A13
Determination of Operational Validity	Annex A14
Appendixes	
Non-Mandatory Suppliers List	Appendix X1

2. Referenced Documents

2.1 *ASTM Standards:*³

- D 86 Test Method for Distillation of Petroleum Products at Atmospheric Pressure
- D 92 Test Method for Flash and Fire Points by Cleveland Open Cup
- D 97 Test Method for Pour Point of Petroleum Products
- D 129 Test Method for Sulfur in Petroleum Products
- D 130 Test Method for Detection of Copper Corrosion from Petroleum Products by the Copper Strip Tarnish Test
- D 287 Test Method for API Gravity of Crude Petroleum and Petroleum Products (Hydrometer Method)
- D 445 Test Method for Kinematic Viscosity of Transparent and Opaque Liquids (the Calculation of Dynamic Viscosity)
- D 482 Test Method for Ash from Petroleum Products
- D 524 Test Method for Ramsbottom Carbon Residue of Petroleum Products
- D 613 Test Method for Cetane Number of Diesel Fuel Oil
- D 664 Test Method for Acid Number of Petroleum Products by Potentiometric Titration
- D 1319 Test Method for Hydrocarbon Types in Liquid Petroleum Products by Fluorescent Indicator Adsorption
- D 2500 Test Method for Cloud Point of Petroleum Products
- D 2622 Test Method for Sulfur in Petroleum Products by Wavelength Dispersive X-ray Fluorescence Spectrometry
- D 2709 Test Method for Water and Sediment in Middle Distillate Fuels by Centrifuge
- D 2896 Test method for Base Number of Petroleum Products by Potentionmetric Perchloric Acid Titration
- D 4485 Specification for Performance of Engine Oils
- D 4737 Test Method for Calculated Cetane Index by Four Variable Equation
- D 4739 Test Method for Base Number Determination by Potentiometric Titration
- D 5185 Test Method for Determination of Additive Elements, Wear Metals, and Contaminants in Used Lubricating Oils and Determination of Selected Elements in Base Oils by Inductively Coupled Plasma Atomic Emission Spectrometry (ICP-AES)
- D 5302 Test Method for Evaluation of Automotive Engine Oils for Inhibition of Deposit Formation and Wear in a Spark-Ignition Internal Combustion Engine Fueled with Gasoline and Operated Under Low-Temperature, Light Duty Conditions⁴
- D 5844 Test Method for Evaluation of Automotive Engine Oils for Inhibition of Rusting (Sequence IID)⁴
- D 5967 Test Method for Evaluation of Diesel Engine Oils in T-8 Diesel Engine
- D 6557 Test Method for Evaluation of Rust Preventive Characteristics of Automotive Engine Oils
- E 29 Practice for Using Significant Digits in Test Data to Determine Conformance with Specifications
- E 344 Terminology Relating to Thermometry in Hydrometry
- ### 2.2 *Coordinating Research Council:*⁵
- CRC Manual No. 12
- CRC Manual No. 18 (Revised May, 1994)

3. Terminology

3.1 *Definitions:*

- 3.1.1 *blind reference oil, n*—a reference oil, the identity of which is unknown by the test facility. **D 5844**
- 3.1.2 *blowby, n*—*in internal combustion engines*, the combustion products and unburned air-and-fuel mixture that enter the crankcase. **D 5302**
- 3.1.3 *calibrate, v*—to determine the indication or output of a measuring device with respect to that of a standard. **E 344**
- 3.1.4 *heavy-duty, adj*— *in internal combustion engine operation*, characterized by average speeds, power output, and internal temperatures that are close to the potential maximum. **D 4485**
- 3.1.5 *heavy-duty engine, adj*— *in internal combustion engines*, one that is designed to allow operation continuously at or close to its peak output. **D 4485**
- 3.1.6 *non-reference oil, n*—any oil other than a reference oil, such as a research formulation, commercial oil, or candidate oil. **D 5844**
- 3.1.7 *non-standard test, n*—a test that is not conducted in conformance with the requirements in the standard test method, such as running on uncalibrated test stand using different test equipment, applying different equipment assembly procedures, or using

³ For referenced ASTM standards, visit the ASTM website, www.astm.org, or contact ASTM Customer Service at service@astm.org. For *Annual Book of ASTM Standards*, Vol 05.01, volume information, refer to the standard's Document Summary page on the ASTM website. *Annual Book of ASTM Standards*, Vol 05.05.

⁴ Withdrawn. *Annual Book of ASTM Standards*, Vol 05.02.

⁵ Available from the Coordinating Research Council, Inc., 219 Perimeter Parkway, Atlanta, GA 30346.

modified operating conditions.

D 5844

3.1.8 *reference oil, n*—an oil of known performance characteristics, used as a basis for comparison.

D 5844

3.1.9 *sludge, n*—in internal combustion engines, a deposit, principally composed of insoluble resins and oxidation products from fuel combustion and the lubricant, that does not drain from engine parts but can be removed by wiping with a cloth.

D 5302

3.1.10 *test oil, n*—any oil subjected to evaluation in an established procedure.

D 6557

3.1.11 *wear, n*—the loss of material from, or relocation of material on, a surface.

3.1.11.1 *Discussion*—Wear generally occurs between two surfaces moving relative to each other, and is the result of mechanical or chemical action or by a combination of mechanical and chemical actions.

D 5844

3.2 *Definitions of Terms Specific to This Standard:*

3.2.1 *crosshead, n*—an overhead component, located between the rocker arm and each intake valve and exhaust valve pair, that transfers rocker arm travel to the opening and closing of each valve pair.

3.2.1.1 *Discussion*—Each cylinder has two crossheads, one for each pair of intake valves and exhaust valves.

3.2.2 *overhead, n*—in internal combustion engines, the components of the valve train located in or above the cylinder head.

3.2.3 *overfuel, v*—an operating condition in which the fuel flow exceeds the standard production setting.

3.2.4 *valve train, n*—in internal combustion engines, the series of components such as valves, crossheads, rocker arms, push rods, and camshaft, that open and close the intake and exhaust valves.

4. Summary of Test Method

4.1 This test method uses a Cummins M11 330 E diesel engine. Test operation includes a 25-min. warm-up, a 2-h break-in, and 200 h in four 50-h stages. During stages A and C, the engine is operated with retarded fuel injection timing and is overfueled to generate excess soot. During stages B and D, the engine is operated at higher load conditions to induce valve train wear.

4.2 Prior to each test, the engine is cleaned and assembled with new cylinder liners, pistons, piston rings, and overhead valve train components. All aspects of the assembly are specified.

4.3 A forced oil drain, oil sample, and oil addition, equivalent to an oil consumption of 0.21 g/kW-h, is performed at the end of each 25-h period.

4.4 The test stand is equipped with the appropriate instrumentation to control engine speed, fuel flow, and other operating parameters.

4.5 Oil performance is determined by assessing valve crosshead wear, sludge deposits, and oil filter plugging.

5. Significance and Use

5.1 This test method was developed to assess the performance of an engine oil to control engine wear and deposits under heavy duty operating conditions selected to accelerate soot production, valve train wear, and deposit formation in a turbocharged, aftercooled four-stroke-cycle diesel engine.

5.2 This test method may be used for engine oil specification acceptance when all details of this test method are in compliance. Applicable engine oil service categories are included in Specification D 4485.

5.3 The test method was correlated with field service data, determined from side-by-side comparisons of two or more oils in on-highway service. These data are contained in a research report.⁶ These same field service oils were used to develop the operating conditions of this test method.

5.4 The design of the engine used in this test method is representative of many, but not all, modern diesel engines. This factor, along with the accelerated operating conditions should be considered when extrapolating test results.

6. Apparatus

6.1 *Test Engine Configuration:*

6.1.1 *Test Engine*—The Cummins M11 330 E is an 11 L in-line turbocharged six-cylinder heavy-duty diesel engine. The engine features a U.S. 1994 emissions configuration with electronic control of fuel metering and fuel injection timing. Obtain the test engine and the engine build parts kit from the supplier listed in A2.2. The components of the engine build parts kit are shown in Table A3.1.

6.1.2 *Oil Heat Exchanger, Adapter Blocks, and Block-off Plate*—The oil heat exchanger is relocated from the stock position with the use of adapter blocks as shown in Fig. A4.1. Install an oil cooler block-off plate on the back of the coolant thermostat housing as shown in Fig. A4.1. The adapter blocks may be obtained from the supplier listed in X1.3. Control the oil temperature by directing engine coolant through the oil heat exchanger (see Fig. A4.2).

6.1.3 *Oil Pan Modification*—Modify the oil pan as shown in Fig. A4.3. A modified oil pan may be obtained from the supplier listed in X1.3.

6.1.4 *Engine Control Module (ECM)*—Obtain the ECM from the supplier listed in A2.2. The ECM programming has been modified to provide overfueling and retarded injection timing to increase soot generation and overhead wear.

6.1.5 *Air Compressor and Fuel Pump*—The engine-mounted air compressor is not used for this test method. Remove the air compressor and install the fuel injection pump in its place (see Fig. A4.4). The fuel injection pump is driven with Cummins coupling P/N 208755. The coupling may be obtained from the supplier listed in X1.1.

6.2 *Test Stand Configuration:*

6.2.1 *Engine Mounting*—Install the engine with the crankshaft in a horizontal orientation. (**Warning** —The engine mounting hardware should be configured to minimize engine block distortion when the engine is secured to the mounts. Excessive block distortion may influence test results.)

6.2.2 *Intake Air System*—With the exception of the air filter and the intake air tube, the intake air system is not specified. A typical configuration is shown in Fig. X2.1. The air filter shall have a minimum initial efficiency rating of 99.2 % (specify micron size). Install the intake air tube (see Fig. A4.5) at the intake of the turbocharger compressor. Construct the system to minimize airflow restriction. A method to cool the intake air may be required. The intake air system shall allow control of the parameters within the ranges listed in Table 5.

NOTE 1—Difficulty in achieving or maintaining intake manifold pressure or intake manifold temperature, or both, could be indicative of excessive restriction.

6.2.3 *Aftercooler*—An assembly comprised of two Cummins aftercoolers, P/N 3801547, is used to control the intake manifold temperature. The two aftercoolers assembled with the air inlet and outlet flanges at opposite ends are as shown in Fig. A4.9. The aftercoolers may be obtained from the supplier listed in X1.1.

6.2.4 *Exhaust System*—Install the exhaust tube (see Fig. A4.6) at the discharge flange of the turbocharger turbine housing. The piping downstream of the exhaust tube is not specified. A method to control exhaust pressure is required.

6.2.5 *Fuel Supply*—The fuel supply and filtration system is not specified. A typical configuration is shown in Fig. X2.2. The fuel consumption rate is determined by measuring the rate of fuel flowing into the day tank. A method to control the fuel temperature is required.

6.2.6 *Coolant System*—The coolant system configuration is not specified. A typical configuration consists of a non-ferrous core heat exchanger, a reservoir (expansion tank), and a temperature control valve as shown in Fig. X2.3. Pressurize the system by regulating air pressure at the top of the expansion tank. The system should have a sight glass to detect air entrapment. (**Warning**—Although the system volume is not specified, an excessively large volume may increase the time required for the engine fluid temperatures to attain specification. A system volume of 45 L or less (including engine) has proven satisfactory.)

6.2.7 *Pressurized Oil Fill System*—The oil fill system is not specified. A typical configuration includes an electric pump, a 50-L reservoir, and transfer hose.

6.2.8 *External Oil System*—Configure the external oil system according to Fig. A5.1. The external reservoir shall be a Moroso P/N 22660, which may be obtained from the supplier listed in X1.4.

6.2.8.1 *Oil Sample Valve Location*—Locate the oil sample valve on the return line from the external oil system to the engine. Locate the valve as close to the return pump as possible (see Fig. A5.1).

6.2.8.2 Brass or copper fittings may influence used oil wear metals analyses and shall not be used in the external oil system.

6.2.9 *Crankcase Ventilation*—Vent the blowby gas at the port located on the left side of the valve cover.

6.2.10 *Blowby Rate*—The flowrate device and system configuration is not specified. Install the system using good engineering practices and operate the flowrate device according to the manufacturer’s guidelines.

6.3 *System Time Responses*—The maximum allowable system time responses are shown in Table 1. Determine system time responses in accordance with the Data Acquisition and Control Automation II (DACA II) Task Force Report.⁷

6.4 *Oil Sample Containers*—High-density polyethylene containers are recommended for oil samples. (**Warning**—Glass containers may break and may cause injury or exposure to hazardous materials, or both.)

6.5 *Mass Balance*—A balance is required to measure the mass of the crossheads and rod bearings. An electronic or mechanical balance may be utilized. The balance shall have a minimum display resolution of 0.1 mg.

7. Engine and Cleaning Fluids

7.1 *Test Oil*—Approximately 75 L of test oil is required to complete the test.

Annual Book of

⁷ Available from the ASTM Standards, Vol 05.04, Test Monitoring Center, 6555 Penn Avenue, Pittsburgh, PA 15206-4489, Attention: Administrator.

TABLE 1 Maximum Allowable System Time Responses

Measurement Type	Time Response (s)
Speed	2.0
Temperature	3.0
Pressure	3.0
Flow	TBD

TABLE 2 Warm-up Conditions

Parameter	Unit	Stage				
		A	B	C	D	E
Stage Length	min	5	5	5	5	5
Speed	r/min	700	1200	1600	1600	1600
Torque	Nom	135	270	540	1085	1470
Coolant Out Temperature ^A	°C	105	105	105	105	105
Oil Gallery Temperature ^A	°C	130	130	130	130	130
Intake Manifold Temperature ^A	°C	70	70	70	70	70

^A Maximum.

TABLE 3 Break-in Conditions

Parameter	Unit	Specification
Stage Length	min	120
Speed	r/min	1600 ± 5
Torque ^A	Nom	1470 (target)
Fuel Flow	kg/h	46-50 (target)
Coolant Out Temperature	°C	88 ± 2
Fuel In Temperature	°C	40 ± 2
Oil Gallery Temperature (target)	°C	115 ± 2
Intake Air Temperature	°C	30 ± 2
Intake Manifold Temperature	°C	record
Oil Gallery Pressure	kPa	record
Oil Filter Delta Pressure	kPa	record
Intake Manifold Pressure	kPa abs.	record
Exhaust Pressure	kPa abs.	107 ± 1
Crankcase Pressure	kPa	record
Inlet Air Pressure	kPa abs.	record

^A At standard atmospheric temperature and pressure.

TABLE 4 Normal Shutdown Conditions

Parameter	unit	Stage		
		B	A	Idle
Stage Length	min	5	5	5
Speed	r/min	1200	700	700
Torque	Nom	270	135	<40
Coolant Out Temperature	°C	105 max	105 max	105 max
Intake Manifold Temperature	°C	70 max	70 max	70 max
Oil Gallery Temperature	°C	130 max	130 max	130 max

7.2 *Test Fuel*—Approximately 13 200 L of diesel fuel is required to complete the test. Purchase the fuel from the supplier listed in A2.1. The fuel shall be within the tolerances shown for all properties listed in Annex A6.

7.3 *Engine Coolant*—Use pre-mixed Fleetguard Compleat PG. The coolant may be obtained from the supplier listed in X1.1.

7.4 *Solvent*—Aliphatic naphtha or equivalent. (**Warning**—Use adequate safety precautions with all solvents and cleaners.)

8. Preparation of Apparatus

8.1 *Cleaning of Parts:*

8.1.1 *General*—The preparation of test engine components specific to the Cummins M11 test are indicated in this section. Use the Cummins service publications⁸ listed in Annex A7 for the preparation of other engine components. Take precautions to prevent rusting of iron components.

8.1.2 *Engine Block*—Disassemble the engine, including removal of the crankshaft, camshaft, piston cooling tubes, oil pump, and oil gallery plugs. Thoroughly clean the surfaces and oil passageways. It is recommended that the oil passageways be cleaned with a brush. Removal of camshaft bearings is at the discretion of the laboratory.

8.1.3 *Cylinder Head*—Disassemble and clean the cylinder head. Use a brush as necessary to remove deposits.

8.1.4 *Rocker Cover and Oil Pan*—Clean the rocker cover and oil pan. Use a brush as necessary to remove deposits.

8.1.5 *External Oil System*—Flush the internal surfaces of the oil lines and the external reservoir with solvent. Repeat until the solvent drains clean. Flush solvent through the oil pumps until the solvent drains clean.

8.1.6 *Crosshead Cleaning and Measurement*— (**Warning**—Avoid handling the crossheads with bare hands, use gloves or plastic covered tongs.)

TABLE 5 200-h Test Sequence

Parameter	Unit	Stage			
		A	B	C	D
Stage Length	h	50	50	50	50
Speed	r/min	1800 ± 5	1600 ± 5	1800 ± 5	1600 ± 5
Power	kW	record	record	record	record
Torque (typical) ^A	Nom	1340-1360	1640-1660	1340-1360	1640-1660
Fuel Flow	kg/h	53 ± 1	53 ± 1	53 ± 1	53 ± 1
Blowby Flow	L/min	record	record	record	record
Coolant Out Temperature	°C	88 ± 2	88 ± 2	88 ± 2	88 ± 2
Coolant In Temperature	°C	record	record	record	record
Coolant Delta Temperature	°C	7 max	7 max	7 max	7 max
Fuel In Temperature	°C	40 ± 2	40 ± 2	40 ± 2	40 ± 2
Oil Gallery Temperature	°C	115 ± 2	115 ± 2	115 ± 2	115 ± 2
Intake Air Temperature	°C	record	record	record	record
Intake Manifold Temperature	°C	46 ± 2	46 ± 2	46 ± 2	46 ± 2
Exhaust Temperature	°C	record	record	record	record
Fuel Pressure	kPa	record	record	record	record
Oil Gallery Pressure	kPa	record	record	record	record
Oil Filter Delta Pressure	kPa	record	record	record	record
Coolant System Pressure ^B	kPa	99 to 107	99 to 107	99 to 107	99 to 107
Intake Manifold Pressure	kPa abs.	record	record	record	record
Exhaust Pressure	kPa abs.	107 ± 1	107 ± 1	107 ± 1	107 ± 1
Crankcase Pressure	kPa	record	record	record	record
Inlet Air Pressure	kPa abs.	record	record	record	record

^A At standard atmospheric temperature and pressure.

^B Measure the coolant pressure on the top of the expansion tank.

8.1.6.1 Clean the crossheads with solvent. Use a non-metallic soft bristle brush if necessary.

8.1.6.2 Spray the crossheads with air until dry.

8.1.6.3 Rinse the crossheads in pentane and dry with air.

8.1.6.4 Measure the mass of each crosshead to a tenth of a milligram (xxx.x mg).

8.1.6.5 If an electronic scale is used for mass measurement, use the following procedure.

(1) Demagnetize each crosshead prior to measurement.

(2) Measure the crosshead two times. Make the second measurement with the crosshead in an orientation that is 90° from the original orientation. If the difference between the two mass measurements is greater than 0.2 mg, demagnetize the crosshead and repeat the measurement process.

8.1.6.6 Report the crosshead measurements on Form 3 listed in Table A9.1.

8.1.7 *Rod Bearing Cleaning and Measurement*—(**Warning**—Avoid handling the rod bearings with bare hands, use gloves or plastic covered tongs.)

8.1.7.1 Clean the rod bearings with solvent; use a non-metallic soft bristle brush, if necessary.

8.1.7.2 Spray the rod bearings with air until dry.

8.1.7.3 Rinse the rod bearings in pentane and dry with air.

8.1.7.4 Measure the mass of each bearing half to a tenth of a milligram (xxx.x mg).

8.1.7.5 Report the rod bearing measurements on Form 6 listed in Table A9.1.

8.2 Engine Assembly:

8.2.1 *General*—Except as noted in this section, use the procedures indicated in the Cummins service publications (see Annex A7). Assemble the engine with the components from the Engine Build Parts Kit (see Annex A3). Other non-kit components are available from the suppliers listed in X1.1 and X1.2.

8.2.2 *Parts Reuse and Replacement*—Engine components may be reused or replaced at the discretion of the laboratory except as noted in 8.2.7.

8.2.3 *Build-Up Oil*—Use Cummins Premium Blue (see X1.1) or test oil to lubricate parts for engine build. If test oil is used, then the engine build is valid only for the respective test oil.

8.2.4 *Coolant Thermostat*—Lock the engine coolant thermostat open or allow it to function normally. The locked-open position is recommended.

8.2.5 *Oil Thermostat*—Remove the oil thermostat and plug the coolant passage. This shall cause all of the oil to flow through the oil cooler.

8.2.6 *Fuel Injectors*—The fuel injectors may be reused. Dedicate the injectors to a particular cylinder. Install the injectors according to the torque wrench method as noted in the Cummins service publications (see Annex A7).

8.2.7 *New Parts*—The parts listed below are contained in the Engine Build Parts Kit and are not reusable (except as noted in 10.3.3). Clean the parts prior to use. Replacement of any part listed in 8.2.7.1–8.2.7.11 during a test shall invalidate the test.

8.2.7.1 Pistons (crown, skirt).

8.2.7.2 Piston rings (top, second, oil).

8.2.7.3 Cylinder liners.

- 8.2.7.4 Rocker lever shafts
- 8.2.7.5 Rocker lever assemblies (exhaust, intake, injector).
- 8.2.7.6 Valves (intake, exhaust).
- 8.2.7.7 Valve stem guides.
- 8.2.7.8 Valve inserts.
- 8.2.7.9 Piston cooling nozzles.
- 8.2.7.10 Valve crossheads.
- 8.2.7.11 Connecting rod bearings.

8.3 *Operational Measurements:*

8.3.1 *Units and Formats*—See Annex A8.

8.3.2 *Instrumentation Calibration :*

8.3.2.1 *Fuel Consumption Rate Measurement Calibration* —Calibrate the fuel consumption rate measurement system before each reference oil test. Temperature-compensate volumetric systems and calibrate them against a mass flow device. The flowmeter located on the test stand shall indicate within 0.2 % of the calibration standard. Trace the calibration standard to national standards.

8.3.2.2 *Temperature Measurement Calibration*—Calibrate the temperature measurement systems at least once every six months. Each temperature measurement system shall indicate within $\pm 0.5^{\circ}\text{C}$ of the laboratory calibration standard. Trace the calibration standard to national standards.

8.3.2.3 *Pressure Measurement Calibration*— Calibrate the pressure measurement systems at least once every six months. Locate the pressure measurement transducers in a temperature-controlled environment to minimize calibration drift. The maximum temperature variation should not exceed 63°C . Trace the calibration standard to national standards.

8.3.3 *Temperatures:*

8.3.3.1 *Measurement Location*—The temperature measurement locations are specified in this section. The measurement equipment is not specified. Install the sensors such that the tip is located midstream of the flow unless otherwise indicated. The accuracy and resolution of the temperature measurement sensors and the complete measurement system shall follow the guidelines detailed in a research report.⁹

8.3.3.2 *Coolant Out Temperature*—Install the sensor at the 1/8-in. NPT port on the thermostat housing as shown in Fig. A4.7.

8.3.3.3 *Coolant In Temperature*—Install the sensor on the right side of the coolant pump intake housing at the 1-in. NPT port as shown in Fig. A4.7.

8.3.3.4 *Fuel In Temperature*—Install the sensor in the fuel pump inlet fitting as shown in Fig. A4.4.

8.3.3.5 *Oil Gallery Temperature*—Install the sensor at the 1/4-in. NPT hole on the left-rear of the engine as shown in Fig. A4.4.

8.3.3.6 *Intake Air Temperature*—Install the sensor as shown on Fig. A4.5.

8.3.3.7 *Intake Manifold Temperature*—Install the sensor at the 1/8-in. NPT hole on the intake manifold as shown in Fig. A4.7.

8.3.3.8 *Exhaust Temperature*—Install the sensor as shown in Fig. A4.6.

8.3.3.9 *Additional*—Monitor any additional temperatures that the laboratory considers beneficial.

NOTE 2—Additional exhaust sensor locations are recommended, such as the exhaust ports and pre-turbine (front and rear). The detection of changes in exhaust temperature(s) is an important diagnostic tool.

8.3.4 *Pressures:*

8.3.4.1 *Measurement Location and Equipment*— The pressure measurement locations are specified in this section. The measurement equipment is not specified. The accuracy and resolution of the pressure measurement sensors and the complete measurement system shall follow the guidelines detailed in a research report.⁹ (**Warning**—A condensation trap should be installed at the lowest elevation of the tubing between the pressure measurement location and the final pressure sensor for Crankcase Pressure, Intake Air Pressure, and Exhaust Pressure. Route the tubing to avoid intermediate loops or low spots before and after the condensation trap.)

8.3.4.2 *Oil Gallery Pressure*—Measure the pressure at the 3/16 in.-18 CompucHECK adapter at the left-front of the engine, as shown in Fig. A4.4.

8.3.4.3 *Oil Filter Inlet Pressure*—Measure the pressure at the 7/8 in.-14 O-ring plug located on the oil filter assembly as shown in Fig. A4.8.

8.3.4.4 *Oil Filter Outlet Pressure*—Measure the pressure at the 1/4-in. NPT port located on the oil filter assembly as shown in Fig. A4.8.

8.3.4.5 *Intake Manifold Pressure*—Measure the pressure at the 1/2-in. NPT port at the top-front of the intake manifold as shown in Fig. A4.7.

8.3.4.6 *Crankcase Pressure*—Measure the pressure at the top-rear of the rocker cover as shown in Fig. A4.2.

8.3.4.7 *Intake Air Pressure*—Measure the pressure on the intake air tube as shown in Fig. A4.5.

8.3.4.8 *Exhaust Pressure*—Measure the pressure on the exhaust tube as shown in Fig. A4.6.

8.3.4.9 *Fuel Pressure*—Measure the pressure at the 1/16-18 Compucheck adapter on fuel pump body as shown in Fig. A4.4.

8.3.4.10 *Coolant Pressure*—Measure the pressure on top of the expansion tank as shown in Fig. X2.3.

8.3.4.11 *Additional*—Monitor any additional pressures considered to be beneficial.

8.3.5 *Flow Rate*:

8.3.5.1 *Flow Rate Location and Measurement Equipment* —The flow rate measurement locations are specified in this section. The equipment for the blowby rate and the fuel rate are not specified. The accuracy and resolution of the flow rate measurement system shall follow the guidelines detailed in a research report.⁹

8.3.5.2 *Blowby*—The device or type of system used to measure the blowby flow rate is not specified. Use engineering judgement and the manufacturer’s guidelines concerning the installation and use of the blowby rate measurement device.

8.3.5.3 *Fuel Flow*—The fuel consumption rate is determined by measuring the fuel flowing to the day tank as shown in Fig. X2.2.

9. Engine/Stand Calibration and Non-Reference Oil Tests

9.1 *General*—Calibrate the test engine and the test stand by conducting a test with a blind reference oil. Submit the results to the ASTM Test Monitoring Center (TMC) for determination of acceptance according to the Lubricant Test Monitoring System (LTMS).⁷

9.1.1 An engine shall not be calibrated for use in more than one test stand during the calibration period of the engine.

9.2 *Calibration Configuration*—To enhance test stand utilization, a maximum of two test engines may be calibrated for use on one test stand. Notify the TMC of the intent to calibrate as either a one-engine stand or a two-engine stand.

9.3 *New Test Stand*—A new test stand is defined as a test stand that has never been calibrated or has not completed an acceptable reference oil test within 182 months of the ~~end-of-test (EOT) date~~ expiration of the last acceptable reference oil test ~~calibration period~~. Under special circumstances, such as industry-wide parts or fuel shortages, the TMC may extend the time period beyond 182 months. Perform the following to introduce a new test stand.

9.3.1 *One-engine Stand*—Conduct two acceptable reference oil tests with one engine.

9.3.2 *Two-engine Stand*—Conduct one acceptable reference oil test with each engine.

9.3.2.1 After a two-engine stand has been calibrated, conduct subsequent reference oil tests by alternating the two engines.

9.3.3 *Special Calibration Acceptance Criteria*—A new stand may be calibrated with only one acceptable reference oil test as detailed in the LTMS.⁷

9.4 *Engine/Stand Calibration Period* :

9.4.1 *Engine*—The calibration period is 12 months from the EOT date of the last acceptable reference oil test.

9.4.2 *One-engine Stand*—The calibration period is 12 months from the EOT date of the last acceptable reference oil test.

9.4.3 *Two-engine Stand*—The calibration period is 6 months from the EOT date of the last acceptable reference oil test.

9.4.4 The TMC may schedule more frequent reference oil tests or extend the calibration period.

9.5 *Change of Calibration Configuration*—The laboratory may change the calibration configuration of a test stand according to the following:

9.5.1 *One-engine to Two-engine Stand*— Notify the TMC and conduct one acceptable reference oil test on a second engine. The stand calibration period shall change to a two-engine stand. However, the calibration period of the first engine shall not exceed 12 months, therefore: (1) If the calibration period of the first engine expires prior to the two-engine stand calibration period, then conduct an acceptable reference oil test on the first engine at the end of its calibration period. (2) Any time remaining in the calibration period of the first engine beyond the calibration period of the two-engine stand is void.

9.5.2 *Two-engine to One-engine Stand*— Notify the TMC and conduct an acceptable reference oil test. The stand calibration period shall change to a one-engine stand. The time remaining on the calibration period of the other engine, if any, is void.

9.5.3 If an engine from a two-engine stand is removed from service, then the stand shall revert to a one-engine stand until the engine is returned to service. The calibration period remains that of a two-engine stand. (**Warning**—Replacement of test engine components may invalidate the calibration status of the engine.)

9.6 *Stand Modification and Calibration Status*—Modification of the test stand control systems or the conducting of any non-standard test, or both, may invalidate the calibration status. A non-standard test includes any test conducted under a modified procedure, non-procedural hardware, controller set-point modifications, or a combination thereof. The TMC should be contacted prior to any changes to determine the effect upon the calibration status.

9.7 *Test Numbering System*:

9.7.1 *General*—The test number has three parts, X-Y-Z. X represents the test stand number, Y represents the engine serial number, and Z represents the engine block run number. For example, test number 27-4B4607-2 indicates stand number 27, engine serial number 4B4607, and the second test on the engine block. Every test start (reference oil and non-reference oil) shall increment Z by one, with the exception stated in 9.7.2.

9.7.2 *Reference Oil Tests*—A reference oil test conducted subsequent to an unacceptable reference oil test shall include a letter suffix after Z. The letter suffix shall begin with A and increment alphabetically until an acceptable reference oil test is completed. For example, if two consecutive unacceptable reference oil tests were conducted and the first test number was 27-4B4607-10, then the second test number would be 27-4B4607-10A. A third calibration attempt would have the test number 27-4B4607-10B. If the third test was acceptable, then 27-4B4607-10B would identify the reference oil test in the test report.

9.7.3 *Non-Reference Oil Tests*—No letter suffix shall be added to Z for aborted or operationally invalid non-reference oil tests.

9.8 *Reference Oil Test Acceptance* :

9.8.1 Reference oil test acceptance and laboratory severity adjustment (SA) are determined in accordance with the LTMS.¹²⁻⁷

9.9 *Unacceptable Reference Oil Test*:

9.9.1 It is recognized that some reference oil test results may not fall within the LTMS acceptance limits. The laboratory, in conjunction with the TMC, shall attempt to determine the cause of the deviation. The TMC may solicit input from industry authorities to help determine the cause and extent of the problem.

9.9.2 If the laboratory is not within the LTMS acceptance limits and the TMC has determined that probable cause is isolated to an individual stand, then non-reference oil testing on other calibrated stands may continue.

9.9.3 If the laboratory is not within the LTMS acceptance limits and the TMC has determined that probable cause involves more than one stand, then the TMC may declare the particular stands non-calibrated. Non-reference oil tests in progress at the time of the calibration status change are not effected.

9.9.3.1 The laboratory shall attempt to identify and correct the cause and conduct an acceptable reference oil test in at least one of the stands to demonstrate resolution of the problem.

9.9.4 The TMC will assign reference oil when satisfied that no particular problems exist or the problem has been resolved. The laboratory shall provide adequate documentation or findings, or both, to support the conclusions reached during this process. The conclusions shall be documented in the acceptable reference oil test report.

9.10 *Reference Oil Accountability* :

9.10.1 Laboratories shall provide a full accounting of the identification and quantities of all reference oils used. With the exception of the oil analyses required in 11.6, perform no physical or chemical analyses of reference oils without written permission from the TMC. In such an event, include the written conformation and the data generated in the reference oil test report.

9.10.2 Retain used reference oil samples for 90 days from the EOT date.

9.11 *Non-Reference Oil Tests*:

9.11.1 This test method incorporates the use of a Severity Adjustment (SA) for non-reference oil test results. A control chart technique described in the LTMS is used to determine if a significant bias exists for crosshead mass loss, average sludge, or oil filter plugging, or a combination thereof. When calibration results indicate a significant bias, an SA is determined according to the LTMS and applied to the non-reference oil test result. The SA and the adjusted result are reported on Form 1 listed in Table A9.1. The SA shall remain in effect until a new SA is determined from subsequent calibration tests.

9.11.2 For a two-engine stand, the two engines shall be alternated between each non-reference oil test.

9.11.3 *Last Start Date*—A non-reference oil test shall commence engine warm-up (see 10.5) prior to the expiration of the calibration period (see 9.4).

10. Test Procedure

10.1 *Engine Installation and Stand Connections*—Install the test engine on the stand and connect the engine to the stand support equipment.

NOTE 3—A final check of valve and injector settings is recommended at this time.

10.2 *Coolant System Fill*—Install a new coolant filter, Cummins WF-2071. Fill the cooling system with pre-mixed Fleetguard Compleat PG. The coolant for non-reference oil tests may be reused provided the level of inhibitors is within specification as determined by DCA Level Test Kit, Cummins P/N CC2602 (see X1.1). Use new coolant for each reference oil test.

NOTE 4—The coolant system should be pressurized to specification and checked for leaks prior to adding the test oil.

10.3 *Oil Fill for Break-in*:

10.3.1 Install a new Cummins LF-3000 oil filter. The filter may be obtained from the supplier listed in X1.1.

10.3.2 Use the pressurized oil fill system (see 6.2.7) to charge the engine with 24.7 kg of test oil at the location shown in Fig. A4.2.

10.3.3 *Engine Build Committed*—Once the test oil has been introduced into the engine, the engine build and the test number are valid only for the respective test. However, if the engine has not been cranked (whereby, the test parts have not been subjected to wear or injected fuel, or both), then the new parts may be used again. Disassemble and clean the engine according to Section 8.

10.4 *Fuel Samples*—Take a 1.0 L fuel sample at the start of the test and at EOT.

10.5 *Engine Warm-up*—The engine warm-up conditions are shown in Table 2.

10.5.1 *Shutdown During Warm-up*—Stop the warm-up timer at the initiation of shutdown. When the laboratory is ready to resume warm-up, start the engine and continue the warm-up from the stage in which the shutdown occurred. The warm-up timer shall resume when the engine speed and the engine torque are within specification.

10.6 *Engine Break-in*—Perform a break-in on each new engine build prior to the start of the 200-h test procedure. The break-in conditions are shown in Table 3.

10.6.1 Start the engine, perform the warm-up (see Table 2) and proceed directly to the break-in (see Table 3).

10.6.1.1 *Shutdown During the Break-in*—Stop the break-in timer at the initiation of shutdown. When the laboratory is ready to resume break-in, start the engine, perform the warm-up, and proceed to the break-in conditions. The break-in timer shall resume

when the engine speed and the engine torque are within specification. If a shutdown occurs within the last 10 min of the break-in, the break-in shall be considered complete. Note such an occurrence in Other Comments of Form 17 listed in Table A9.1.

10.6.2 At the completion of break-in, perform a normal shutdown (see Table 4) and shut off the engine.

10.6.3 Drain the oil from the engine and the external oil system.

10.6.4 Remove the LF-3000 oil filter.

10.6.5 Properly dispose of the drain oil and oil filter.

10.6.6 Once completed, the break-in is not repeated for the respective test.

NOTE 5—Use the break-in as an opportunity to confirm engine performance and to make repairs prior to the start of the 200-h test procedure.

10.7 *Shutdown and Maintenance*—The test may be shut down at the discretion of the laboratory to perform repairs. However, the intent of this test method is to conduct the 200-h procedure uninterrupted.

10.7.1 *Normal Shutdown*—Proceed directly from the operating conditions to the shutdown schedule in Table 4.

10.7.2 *Emergency Shutdown*—An emergency shutdown occurs when the normal shutdown was not performed, such as an alarm condition. Include Emergency Shutdown on the downtime report of Form 17 shown in Table A9.1.

10.7.3 *Maintenance*—Engine components or stand support equipment, or both, may be repaired or replaced at the discretion of the laboratory and in accordance with this test method.

10.7.3.1 Removal of the crossheads prior to test completion shall invalidate the test.

10.7.4 *Downtime*—The limit for total downtime and number of shutdowns is not specified. Record all shutdowns, pertinent actions, and total downtime during the 200-h test procedure on Form 17 shown in Table A9.1.

10.8 *200-h Test Procedure*:

10.8.1 Measure and record the mass of a new test oil filter, Cummins P/N 390383200 (see Table A3.1), and install the oil filter on the engine.

10.8.2 *Oil Fill for Test*—Using the pressurized oil fill system (see 6.2.7), charge the engine with 24.7 kg of test oil at the location shown in Fig. A4.2.

10.8.3 Start the engine and perform the warm-up (see Table 2).

10.8.3.1 *Zero-hour Oil Sample*—During Stage E of the warm-up, remove a 0.23 kg oil purge sample, and remove a 0.23 kg oil analysis sample. Return the purge sample to the external oil system.

10.8.4 *Operating Conditions*—After warm-up, proceed directly to the 200-h Test Sequence (see Table 5).

10.8.4.1 *Stage Transition Times*—1 min (r/min only).

10.8.5 *Injection Timing Change*—The fuel injection timing may be adjusted once between 50 and 100 h to meet the 150-h % soot target, provided the 50-h soot is at least 2.1 %.

10.8.6 *Mass % Soot Validity* :

10.8.6.1 *Reference Oil Test*—Mass % soot shall be 5 ± 0.5 % at 150 h.

10.8.6.2 *Non-Reference Oil Test*—Mass % soot shall be a minimum of 4.5 % at 150 h.

10.8.7 *Test Timer*—The 200-h test sequence timer starts when all controlled parameters shown in Stage A of Table 5 are within specification. If a shutdown(s) occurs, the test timer stops immediately at the initiation of the shutdown. The test timer resumes when the test has been returned to the appropriate stage and all controlled parameters are within specification.

10.8.7.1 The test timer continues incrementing through stage transitions.

10.8.8 *Operational Data Acquisition*—Record all operational parameters shown in Table 5, except Blowby Flow, with automated data acquisition at a minimum frequency of once every 6 min. Record Blowby Flow a minimum of once every 8 h. Recorded values shall have minimum resolution in accordance with Annex A8. Report the characteristics of the data acquisition system on Form 18 listed in Table A9.1.

10.8.8.1 The operational data is reported on Form 2 listed in Table A9.1.

10.8.9 *Oil Purge, Oil Sample, and Oil Addition*—Perform a forced oil drain, oil sample, and oil addition at the end of each 25-h period. Add the new oil and the purge sample to the external oil system reservoir.

10.8.9.1 Do not shut down the engine for oil sampling and oil addition. Purge oil samples are retained at the discretion of the laboratory.

10.8.9.2 *Full and Drain Weight*—Record the oil weight indicated by the external oil system at the completion of the first test hour, this value establishes the full weight. Subtract 1.4 kg (3.1 lb) from the full weight, this value establishes the drain weight. The full weight and the drain weight are fixed for the test.

10.8.9.3 At the end of each 25-h period, take a 0.23 kg (0.51 lb) oil purge sample followed by a 0.23 kg (0.51 lb) oil analysis sample. Identify the oil sample container with the test number, oil code, date, and test hour.

10.8.9.4 If the remaining oil weight is greater than the drain weight, then remove an additional purge sample of sufficient quantity to equal the drain weight.

10.8.9.5 If the remaining oil weight is less than the drain weight, then add a maximum of 0.23 kg (0.51 lb) of the current purge oil sample to attain the drain weight. Do not add any new oil or a previous purge oil sample to attain the drain weight.

10.8.9.6 Add 1.4 kg (3.1 lb) of new oil, except at 200 h.

10.9 *End of Test (EOT)*:

10.9.1 After completing the 200-h test procedure, perform a normal shutdown (see Table 4), and shut off the engine. Release

the coolant system pressure and drain the coolant. Disconnect the stand support equipment. (**Warning**—The coolant and oil could be hot. The installation of a valve to safely vent the coolant system pressure is recommended.)

10.9.2 Drain the oil from the engine and the external oil system. Commence the oil drain within 2 h after shutdown and allow a minimum duration of 30 min.

10.9.3 Retain a minimum of two 3.5 L samples of test oil. Identify the oil sample container with the test number, oil code, EOT date, and test hour. Properly dispose of any residual oil drain.

10.9.4 *Engine Disassembly*—Disassemble the engine and remove the following components for ratings or measurements, or both:

10.9.4.1 *Rocker Cover and Oil Pan*—The rocker cover and oil pan may either remain on the engine or be removed from the engine. However, maintain the rocker cover and oil pan in a horizontal position for a minimum of 6 h after the EOT oil drain.

(1) *Rocker Cover and Oil Pan Sludge Rating*—After 6 h in a horizontal plane, place the oil pan and rocker cover at a 60° angle from horizontal (lengthwise) with the front end and the inside surface down for a minimum of 8 h in a temperature-controlled environment.

10.9.4.2 *Crossheads*.

10.9.4.3 *Pistons*.

10.9.4.4 *Piston Rings*.

10.9.4.5 *Rod Bearings*.

11. Calculations, Ratings, and Test Validity

11.1 *Crosshead Mass Loss*—Use the procedure shown in 8.1.6 to determine individual EOT crosshead mass. Report the crosshead measurements and calculation results on Form 3 listed in Table A9.1.

11.1.1 Calculate the average mass loss, \bar{x} , for each crosshead population (intake and exhaust).

11.1.2 Calculate the Δ/s for each crosshead as follows:

$$\Delta/s = (x_i - \bar{x})/s \quad (1)$$

where:

x_i = individual crosshead mass loss, mg,

\bar{x} = average mass loss of crosshead group (intake or exhaust), and

s = industry standard deviation, shown in the following table.

Crosshead Group	Industry Standard Deviation (s)	
	Test Kit # CK11-751-A/B and prior test kits	Test Kit # CK11-752-A/B and subsequent test kits
Intake	2.20	3.48
Exhaust	3.68	5.89

11.1.3 If the maximum Δ/s value of a crosshead group is less than or equal to the critical value shown in the table below, then there are no outliers. Proceed to 11.1.6.

11.1.4 If the maximum Δ/s value of a crosshead group is greater than the critical value shown in the following table, then that crosshead is an outlier. Remove only that crosshead from the group, even if other Δ/s values exceed the critical value.

Number of Crossheads in Group	Critical Value
6	2.40
5	2.29
4	2.15
3	1.93

11.1.5 Repeat the calculations in 11.1.1-11.1.4 for the group using the remaining crossheads and adjusting the critical value for the change in the number of crossheads in the group. Perform a maximum of two iterations (that is, a maximum of two crossheads per group may be declared as outliers). Report the outlier adjusted results on Form 3 listed in Table A9.1.

NOTE 6—For tests that do not use the full complement of six crossheads per group (for example, split tests on new hardware) to determine test results, only one outlier screening iteration is allowed. (That is, a maximum of one crosshead per group may be declared an outlier.)

11.1.6 Calculate the average and the standard deviation of all mass loss values combined (intake and exhaust) with any outliers removed. Report the average and standard deviation values as Outlier Screened in the Overall Summary.

11.1.7 Calculate the following and report as Adjusted to 4.5 mass % Soot in the Overall Summary:

$$\exp[(\ln(X) \cdot (4.5 \text{ Mass \%}) / (\text{Mass \% Soot at 150 h}))] \quad (2)$$

where:

X = Outlier Screened Crosshead Average Mass Loss value in the Overall Summary.

11.2 *Rod Bearing Mass Loss*—Use the procedure shown in 8.1.7 to determine individual EOT rod bearing mass. Report the rod bearing measurements and calculations on Form 6 listed in Table A9.1.

11.2.1 Calculate the mass loss for each rod bearing section (pre-test – post test).

11.2.2 Calculate the average mass loss and the standard deviation of the mass loss.

11.3 Sludge Ratings:

11.3.1 Rate the rocker arm cover sludge and the oil pan sludge according to CRC Manual No. 12 at the locations specified in Figs. A10.1 and A10.2, respectively, and report on Form 3 listed in Table A9.1.

11.3.2 Average the rocker arm cover sludge and oil pan sludge ratings. Report as Average Sludge Rating on Form 5 listed in Table A9.1.

11.4 *Piston Ratings*—Rate the pistons according to CRC Manual No. 18 (Revised May 1994) at the locations specified using the special instructions noted in Annex A11. Report the ratings on Form 8-13 listed in Table A9.1. For the varnish ratings, use the CRC expanded varnish scale and convert to demerits.

11.5 *Oil Filter Plugging*—Oil filter plugging (ΔP_{FP}) is indicated by the increase of the oil filter differential pressure (ΔP) during the test. A correction to the ΔP may be required to account for the effect of a shutdown. The general equation for oil filter plugging is as follows:

$$\Delta P_{FP} = \Delta P_{ADJ(MAX)} - \Delta P_{INIT} \quad (3)$$

$$\Delta P = \text{Oil Filter Outlet Pressure} - \text{Oil Filter Inlet Pressure} \quad (4)$$

where:

$\Delta P_{ADJ(MAX)}$ = maximum adjusted ΔP during the test (Eq 6), and

ΔP_{INIT} = first ΔP reading of the test with target and range parameters within specification.

11.5.1 *No Shutdowns*—No correction is performed, Eq 3 becomes:

$$\Delta P_{FP} = \Delta P_{MAX} - \Delta P_{INIT} \quad (5)$$

where:

ΔP_{MAX} = maximum ΔP during the test.

11.5.2 *Shutdowns*—Separate the test into segments demarcated by shutdowns (see Fig. A13.1). Segment 1 is from the SOT to shutdown 1, Segment 2 is from shutdown 1 to shutdown 2, and so forth.

11.5.2.1 *ΔP Correction*—Determine the correction due to each shutdown:

(1) If $\Delta P_{BS(N)} - \Delta P_{AS(N)} < 4$ kPa, then $\Delta P_{CORR(N)} = 0$

(2) If $\Delta P_{BS(N)} - \Delta P_{AS(N)} > 4$ kPa, then $\Delta P_{CORR(N)} = \Delta P_{BS(N)} - \Delta P_{AS(N)}$

where:

N = shutdown number,

$\Delta P_{BS(N)}$ = last ΔP reading before initiation of shutdown N ,

$\Delta P_{AS(N)}$ = first ΔP reading after shutdown N with target and range parameters within specification, and

$\Delta P_{CORR(N)}$ = ΔP correction due to shutdown N .

11.5.2.2 *Adjusted ΔP* —Add ΔP_{CORR} to each ΔP reading subsequent to the shutdown. In general, sum the ΔP_{CORR} of prior shutdowns and add to each ΔP reading of the current segment (see Fig. A13.2).

$$\Delta P_{ADJ(N)} = \Delta P_N + [\sum \Delta P_{CORR(N-1)}]_{2, \dots, N} \quad (6)$$

where:

N = segment number,

$\Delta P_{ADJ(N)}$ = adjusted ΔP readings during segment N ,

ΔP_N = individual ΔP readings during segment N ,

$\Delta P_{CORR(N)}$ = ΔP correction at shutdown N , and

$\Delta P_{ADJ(1)}$ = ΔP_1 .

11.5.3 Report oil filter plugging (ΔP_{FP}) as Filter Plugging Delta P on Form 1 listed in Table A9.1 for a non-reference oil test or on Form 1A listed in Table A9.1 for a reference oil test.

11.5.4 Plot ΔP versus test hour on Form 4 listed in Table A9.1.

11.6 *Oil Analyses*—Analyze the oil samples for viscosity at 100°C, wear metals (iron, copper, lead), TAN, TBN, and % soot (TGA) according to the schedule and methods shown in Annex A12. Report these values on Form 15 listed in Table A9.1.

11.7 *Oil Consumption*—Sum the weight of the oil consumed for the test and report on Form 1 listed in Table A9.1 for a non-reference oil test or on Form 3 listed in Table A9.1 for a reference oil test. The test is non-interpretable if the oil consumption exceeds 15 kg.

11.8 *Fuel Analyses*—Report the analyses provided by the fuel supplier on Form 16 listed in Table A9.1. Report the analyses of the final batch if more than one fuel batch was used.

11.8.1 *Additional Analyses*—Perform the following analyses on the 1 L new and EOT fuel samples, and report on Form 16 listed in Table A9.1.

11.8.1.1 *API Gravity*—at 15.6°C (60°F), Test Method D 287 or equivalent.

11.8.1.2 *Total Sulfur*—% weight, Test Method D 129 or equivalent.

11.9 *Ring Mass Loss*—Report the piston ring measurements and calculations on Form 14 listed in Table A9.1.

11.9.1 Calculate the mass loss for the top and second ring (pre-test – post test).

11.9.2 Calculate the average mass loss and the standard deviation of the mass loss for the top and second ring.

11.10 *Assessment of Operational Validity*— Determine operational validity according to Annex A14. Test validity is reported on Form 1 listed in A9.1.

11.11 *Assessment of Test Interpretability*—A test is non-interpretable when the total oil consumption exceeds 15 kg. A non-reference test is non-interpretable when the 150 h soot is less than 4.5 %. Interpretability is reported on Form 1 listed in Table A9.1.

12. Test Report

12.1 *Report Forms*—For reference oil tests, the standardized report form set and data dictionary for reporting test results and for summarizing the operational data are required. Instructions for obtaining the report forms and data dictionary are shown in Annex A9.

12.2 *Reference Oil Test*—Send Forms 0, 1A, 2, 3, 5, 15, and 17 listed in Table A9.1, and any other supporting information, to the TMC⁷ by facsimile or electronic transmission within five days of the EOT date for test acceptance determination. Reference oil test reports should be mailed or electronically transmitted to the TMC within 30 days of the EOT date.

12.2.1 *Electronic Transmission of Test Results*—Use ASTM Data Communications Committee Test Report Transmission Model (Section 2—Flat File Transmission Format).⁷

13. Precision and Bias

13.1 *Precision*—Precision is based on operationally valid calibration test results monitored by the TMC. The research report contains industry data developed prior to the establishment of this test method.

13.1.1 *Intermediate Precision (formerly called repeatability) Conditions*—Conditions where test results are obtained with the same test method using the same test oil, with changing conditions such as operators, measuring equipment, test stands, test engines, and time.

13.1.1.1 *Intermediate Precision Limit (i.p.)*—The difference between two results obtained under intermediate precision conditions that would in the long run, in the normal and correct conduct of the test method, exceed the values shown in Table 6 in only one case in twenty.

13.1.2 *Reproducibility Conditions*—Conditions where test results are obtained with the same test method using the same test oil in different laboratories with different operators using different equipment.

13.1.2.1 *Reproducibility Limit (R)*—The difference between results obtained under reproducibility conditions that would, in the long run, in the normal and correct conduct of the test method, exceed the values in Table 6 in only one case in twenty.

13.2 *Bias*—Bias is determined by applying a defined statistical technique to calibration test results. When a significant bias is determined, a severity adjustment is applied to the non-reference oil test result.

14. Keywords

14.1 crosshead; Cummins M11; diesel engine oil; oil filter plugging; sludge; soot-induced stress

ANNEXES

(Mandatory Information)

A1. SAFETY PRECAUTIONS

A1.1 Operating engine tests may expose personnel and facilities to safety hazards. Personnel trained and experienced with engine testing should perform the design, installation, and operation of test stands.

A1.2 Guards (shields) should be installed around all external moving, hot, or cold components. Design the guard to contain the energy level of a rotating component should the component break free. Fuel, oil, coolant, and electrical wiring should be properly routed, guarded, and grounded and kept in good order.

A1.3 The test stand should be kept free of oil and fuel spills and tripping hazards. Containers of oil or fuel, or both, should not be permitted to accumulate in the testing area. Fire fighting equipment should be immediately accessible. Normal precautions should be observed whenever using flammable solvents for cleaning purposes.

TABLE 6 Test Precision

Parameter ^A	Intermediate Precision (ip)	Reproducibility (R)
Average Sludge	1.07	0.80
Crosshead Mass Loss	6.79	6.62
Oil Filter Plugging	0.95	0.78

^A Precision data are periodically updated and are available from the TMC.

A1.4 Safety masks, glasses, or hearing protection, or a combination thereof, should be worn by personnel working on the test stand. No loose or flowing clothing, including long hair or other accessory to dress, should be worn near rotating equipment. Personnel should be cautioned against working alongside the engine and driveline while the engine is running.

A1.5 Interlocks should automatically shutdown the engine when an anomaly in any of the following occur: engine or dynamometer coolant temperature, engine oil pressure, dynamometer field current, engine speed, exhaust temperature, excessive vibration or when the fire protection system is activated. The interlock should include a method to cut off the fuel supply to the engine at the injector pump (including the return line). A remote fuel cut off station (external to the test stand) is recommended.

A1.6 Employ other safety precautions as required by regulations.

A2. SUPPLIER LIST

A2.1 Obtain the test fuel from the supplier:

Specified Fuels & Chemicals
1201 S. Sheldon Rd.
P.O. Box 429
Channelview, TX 77530-0429

A2.2 Obtain the test engine, the engine build parts kit, and the ECM from the central parts distributor (CPD). Direct questions or correspondence concerning Cummins test parts to the CPD:

Test Engineering, Inc.
12758 Cimarron Path, Suite 102
San Antonio, TX 78249-3417
Phone: (210) 690-1958
Fax: (210) 690-1959

A3. ENGINE BUILD PARTS KIT

A4. SENSOR LOCATIONS AND SPECIAL HARDWARE

A4.1 See Figs. A4.1-A4.9.



TABLE A3.1 Engine Build Parts Kit

Description	Cummins P/N	Per Kit	Critical	
Cam Follower Parts				
Injector cam follower (old material)	3328628	3	Y	
Valve cam follower (old material)	3328630	6	Y	
Injector lever (new material)	3161473	3	Y	
Valve lever (new material)	3161475	6	Y	
Cam follower shaft	3895833	2		
Drive plug	3019630	8		
Cam follower shaft support	3064582	1		
Cam follower shaft support	3895831	1		
Cam follower shaft support (center)	3895830	5		
Cam follower shaft support (end)	3064583	1		
Plain washer	3009330	7		
Cylinder Head Parts				
Expansion plug	3007632	2		
Expansion plug	206741	2		
Expansion plug	3007635	8		
Valve insert (exhaust)	3088980	12		
Valve insert (intake)	3088978	12		
Valve stem guide	3073512	24		
Valve spring	3895860	24	Y	
Intake valve	3080975	12		
Valve collet	3275354	48		
Exhaust valve	3080976	12		
Valve spring retainer	3883512	24		
Spring guide	3070072	24		
Pipe plug	3008465	16		
Orifice plug	3820749	6		
Valve stem seal, intake	3073509	12		
Valve stem seal, exhaust	3328781	12		
Expansion plug	3895479	2		
Overhead Components				
Rocker lever assembly (exhaust)	3064600 or 3400971	3064602 or 4003903	3	Y
Rocker lever assembly (exhaust)	3064597 or 3400974	3064599 or 4003906	3	Y
Rocker lever assembly (intake)	3088350 or 3400972	3064605 or 4003904	3	Y
Rocker lever assembly (intake)	3068351 or 3400973	3064608 or 4003905	3	Y
Rocker lever assembly (injector)	3069020	3068947	6	Y
Rocker lever shaft	3803166	3820750	2	Y
Valve crosshead	3070175		12	Y
Push rod	3068390		12	
Push rod	3076046		6	
Rocker lever support	3893584		4	
Rocker lever support	3079662		2	
Rocker lever support	3079661		2	
Retaining clamp	3077444		8	
Piston/Rings/Liner				
Piston top	3896030	6	Y	
Piston skirt	3081334	6	Y	
Piston pin	3063843	6		
Retaining ring	3016652	12		
Top compression ring	3893752	6	Y	
Second compression ring	3899413	6	Y	
Oil ring	3899561	6		
Cylinder liner	3080760	6	Y	
Miscellaneous Components				
Pressure regulator plunger	3068979	1		
Compression spring	3010146	1		
Retainer plug	3895718	1		
Piston cooling nozzle	3080708	6		
Rectangular seal	3047188	6		
Oil cooler	3081359	1		
Connecting rod bearing	3016760	12	Y	
Oil filter	390383200	1	Y	

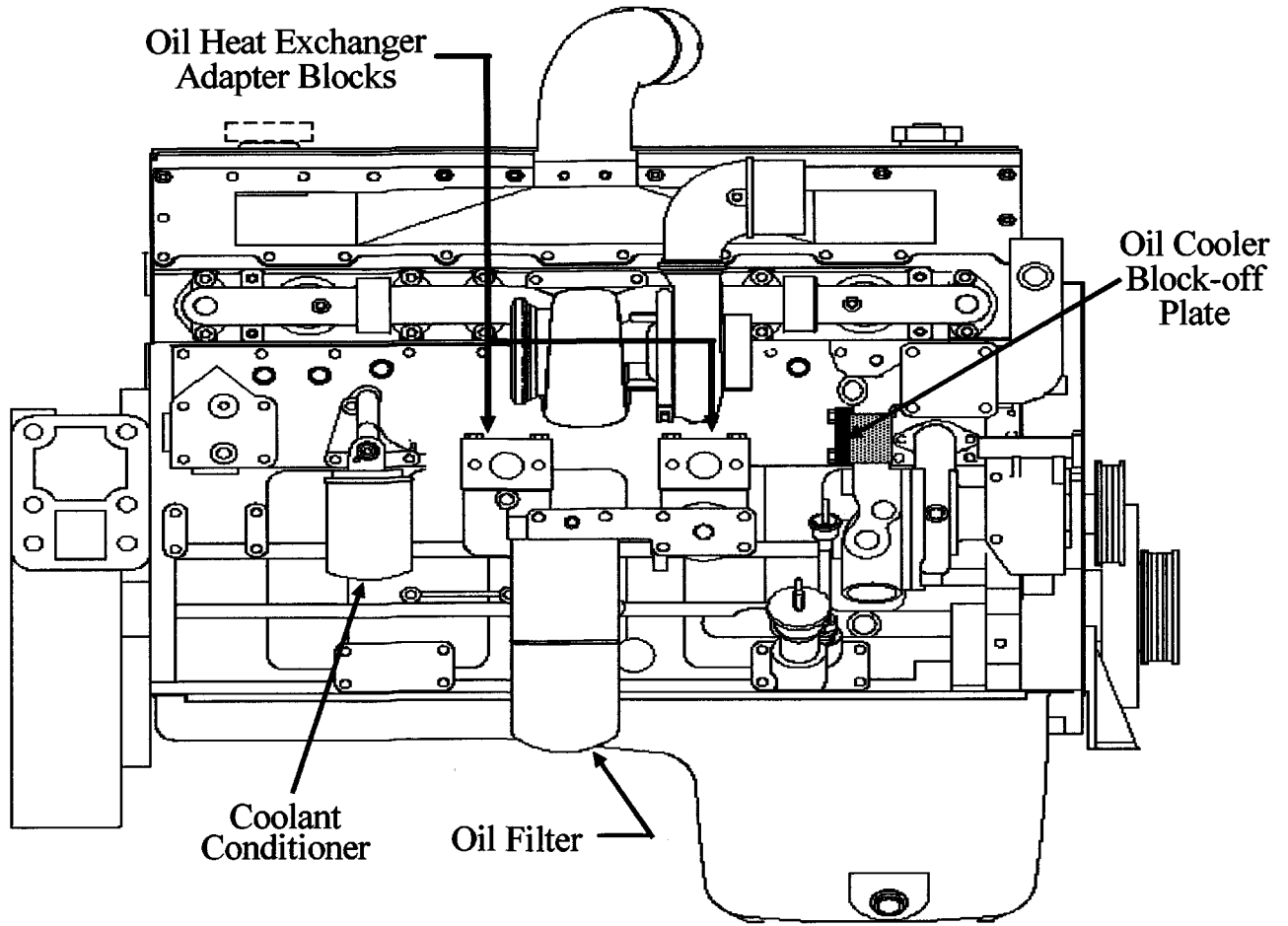

FIG. A4.1 Oil Heat Exchanger Adapter Blocks, Oil Cooler Block-off Plate

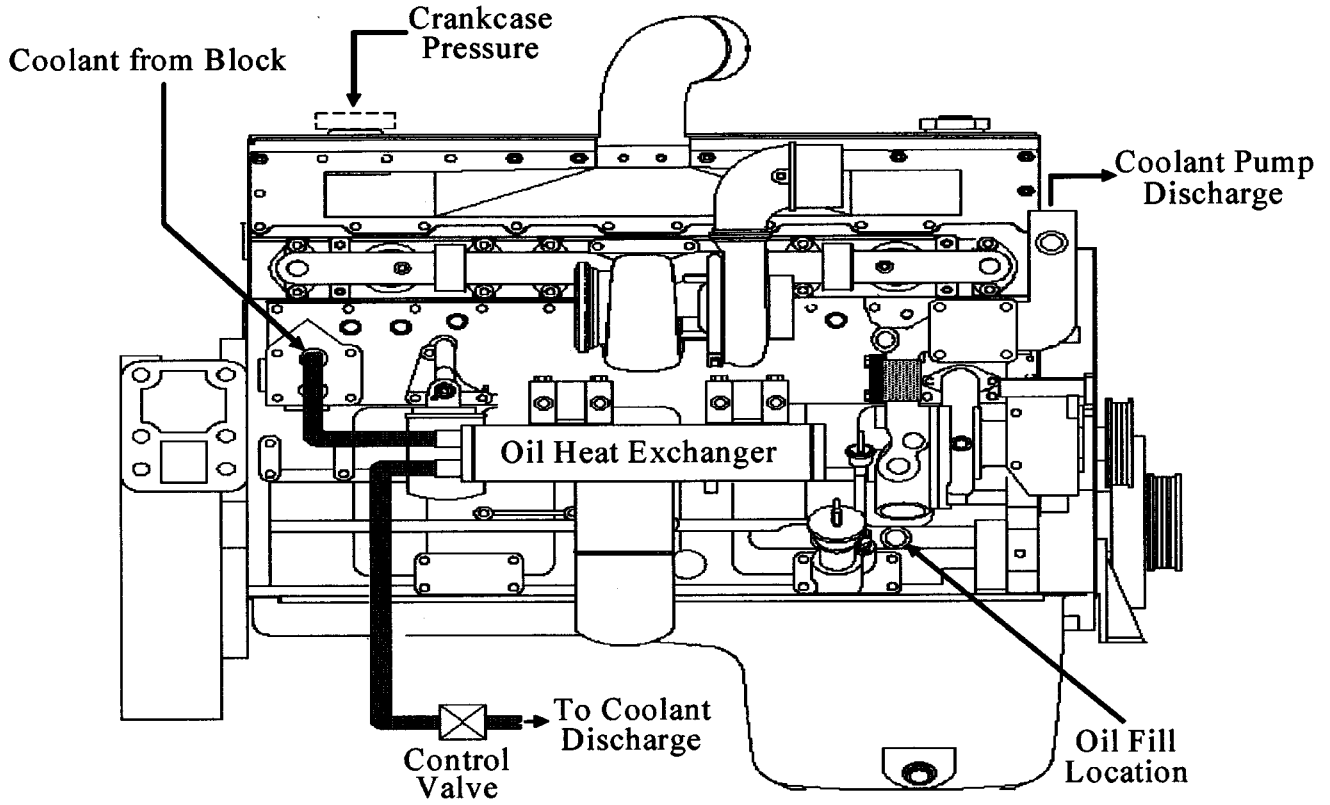

FIG. A4.2 Oil Heat Exchanger, Oil Fill Location, Crankcase Pressure

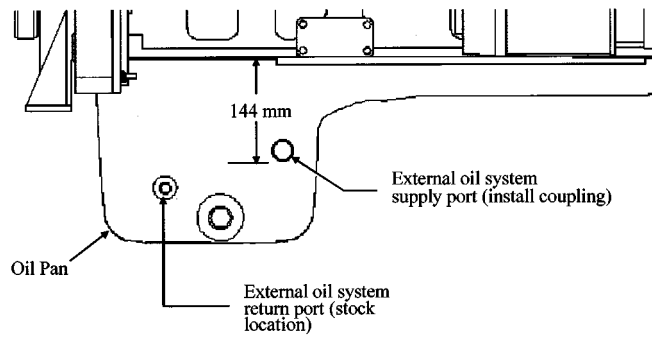

FIG. A4.3 Oil Pan Modifications

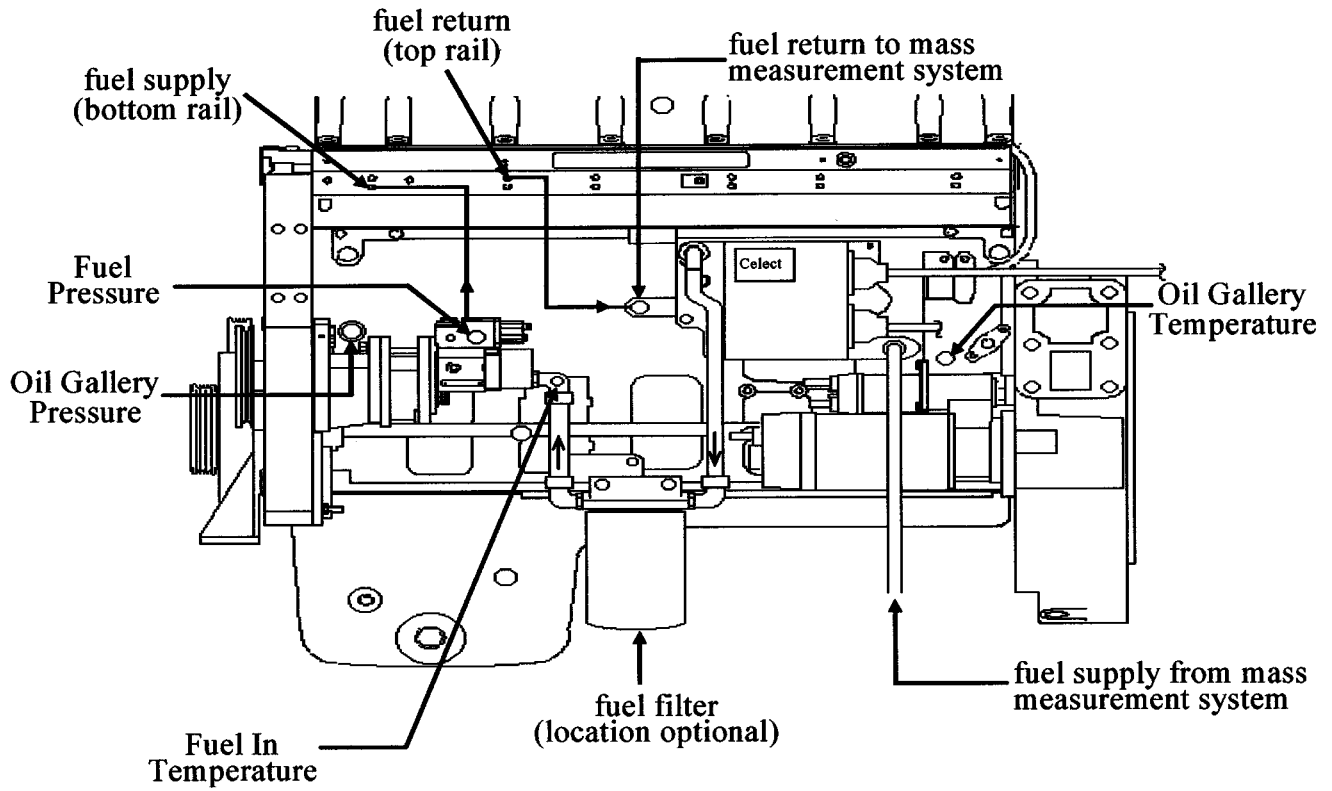
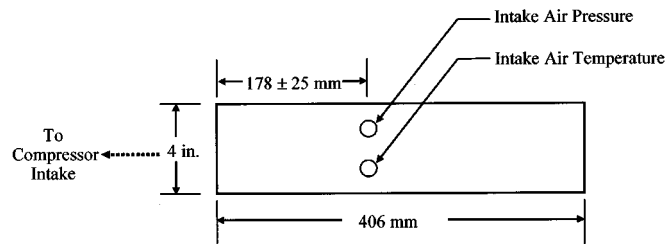
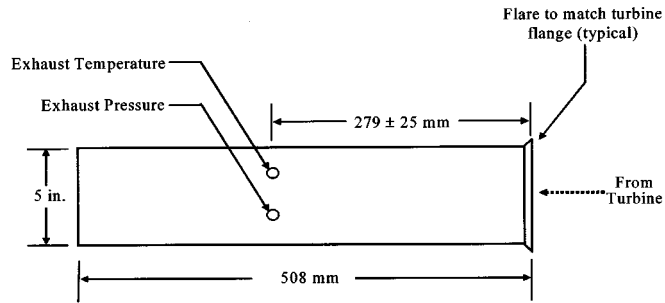

FIG. A4.4 Fuel In Temperature, Fuel Pressure, Oil Gallery Temperature, Oil Gallery Pressure



NOTE 1—The relative radial position and spacing of intake air restriction and intake air temperature is not specified.
 NOTE 2—Tubing: 4 in. O.D. by 0.0625 in. wall thickness.

FIG. A4.5 Intake Air Tube



NOTE 1—The relative radial position and spacing of exhaust pressure and exhaust temperature is not specified.
 NOTE 2—Tubing: 5 in. O.D. by 0.0625 in. wall thickness.

FIG. A4.6 Exhaust Tube

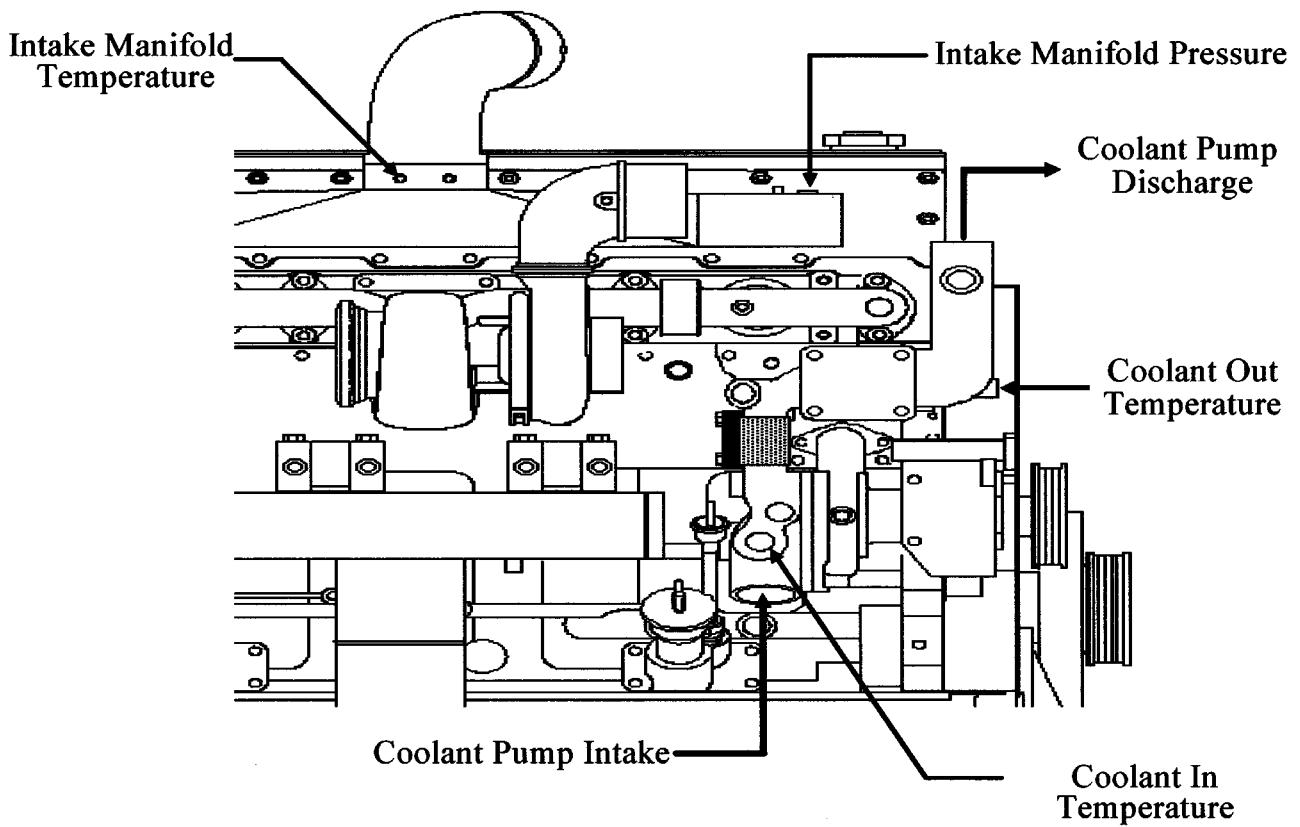

FIG. A4.7 Intake Manifold Pressure, Intake Manifold Temperature, Coolant Out Temperature, Coolant In Temperature

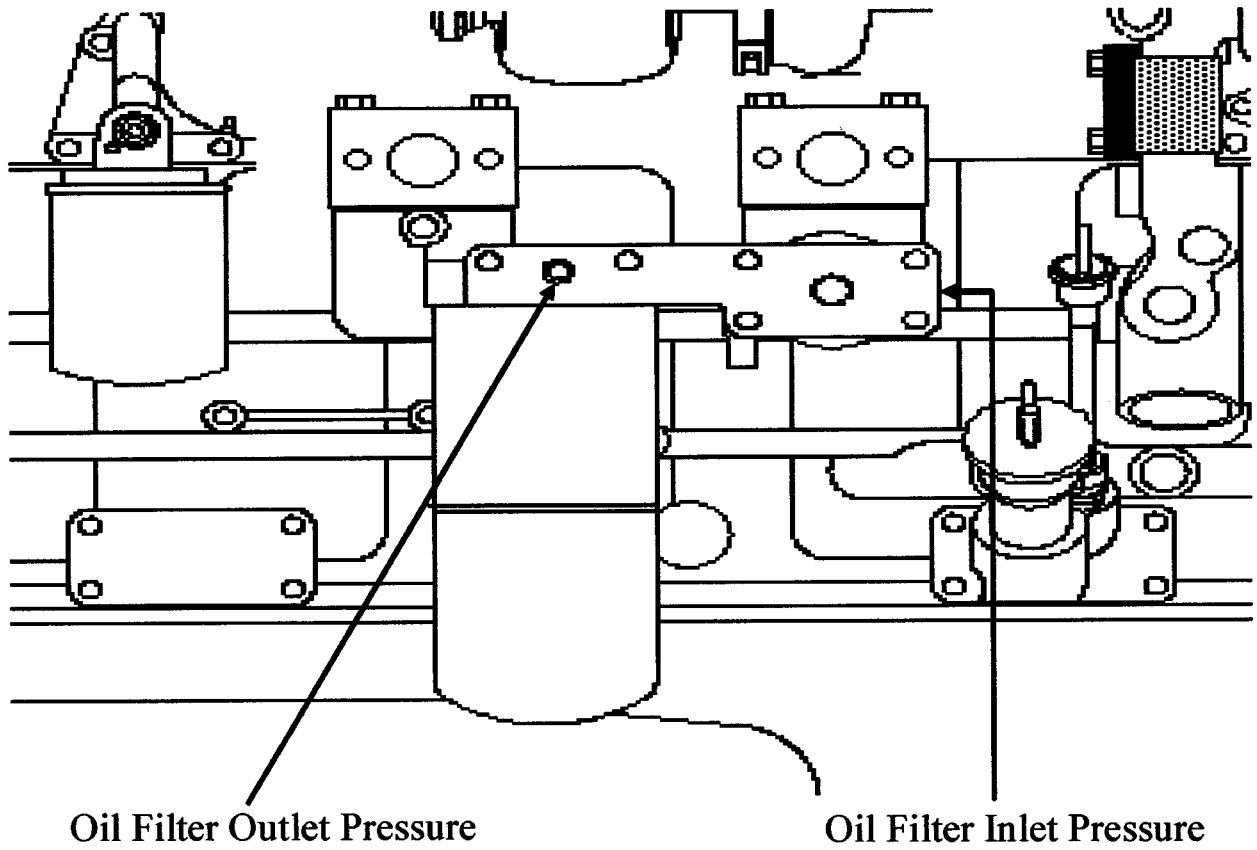
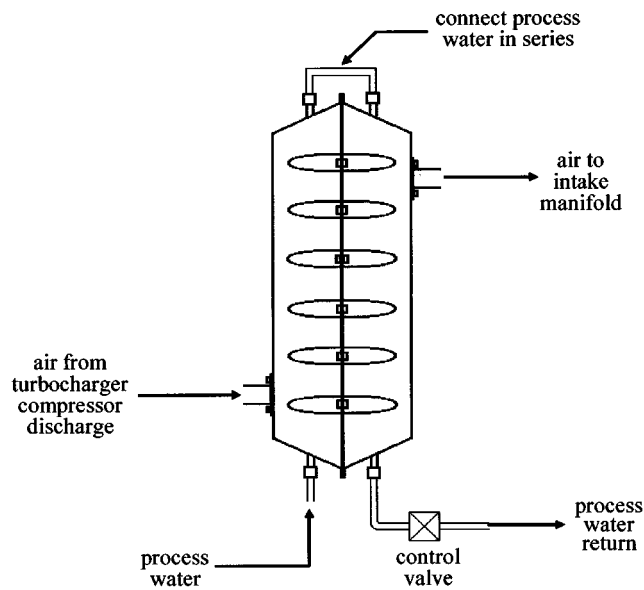

FIG. A4.8 Oil Filter Outlet Pressure, Oil Filter Inlet Pressure



NOTE—Process water connections can be reconfigured for laboratory convenience.
 FIG. A4.9 After Cooler Assembly

A5. EXTERNAL OIL SYSTEM

A5.1 See Fig. A5.1.

Pump Flowrate:
 $P_r = 4 - 8 \text{ L/min (1 - 2 gal/min)}$
 $P_s = 1.5 * P_r$
 Hoses:
 Supply - 12 mm (1/2 in.)
 Return - 10 mm (3/8 in.)
 Vent - 12mm (1/2 in.) minimum

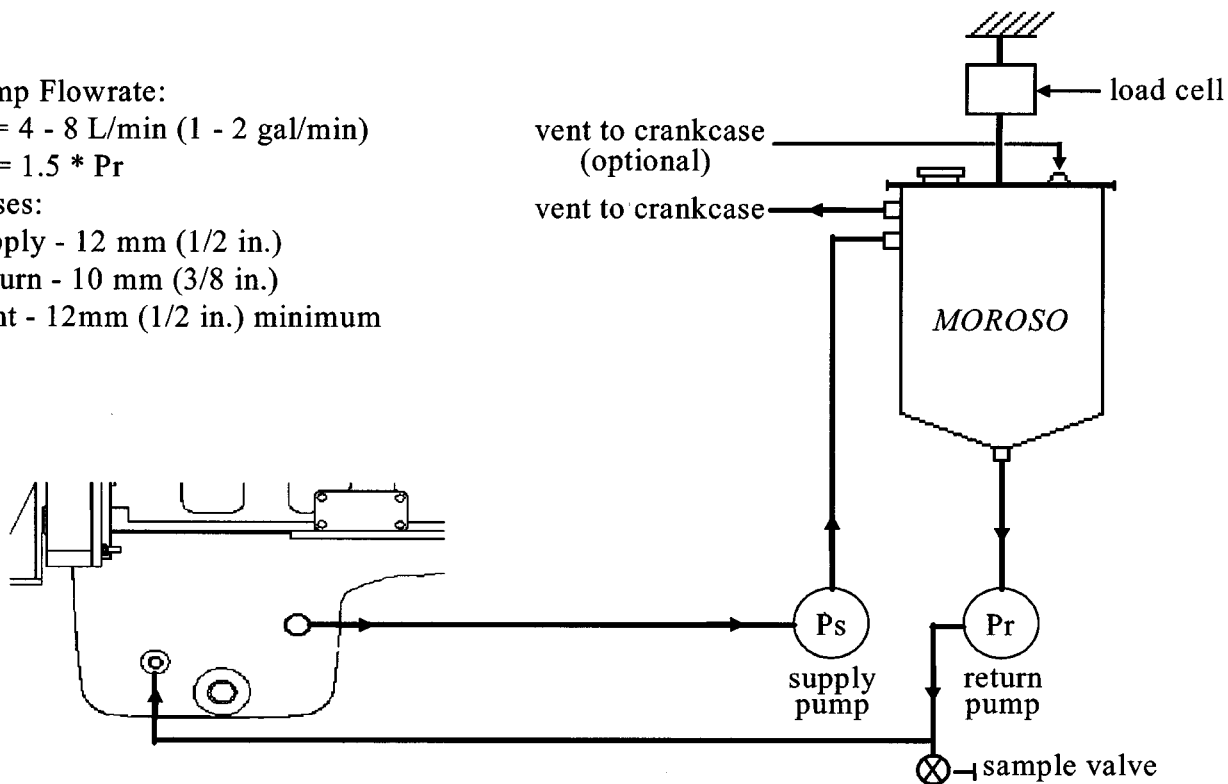

FIG. A5.1 External Oil System

A6. FUEL SPECIFICATION

A6.1 See Table A6.1.

A7. CUMMINS SERVICE PUBLICATIONS

A7.1 General preparation techniques for Cummins M11 engines are detailed in the Cummins publication titled, Shop Manual—M11 Series Engines, Bulletin No. 3666075-00.

A7.2 Engine specifications, component specifications, and torque values are shown in the Cummins publication titled, Specification Manual—M11 Series Engines, Bulletin No. 3666076-00.

A7.3 Troubleshooting and repair information is shown in the Cummins publication titled, Troubleshooting and Repair Manual—M11 Series Engines, Bulletin No. 3666074-00.

A7.4 Valve train overhead adjustments are shown in a video tape titled, N14/L10 Command Select Overhead Adjustments, Bulletin No. 3387746.

A7.5 Information concerning the reuse of overhead components is shown in the Cummins publication titled, Cummins Overhead Reuse Guidelines L-10 Series Engines, Bulletin No. 3810388-00.

TABLE A6.1 Low Sulfur Reference Diesel Fuel for Heavy Duty Engine Oil Tests

Property	Test Method	Min	Max
Sulfur, % weight	D 2622	0.03	0.05
Gravity, °API	D 287	32	36
Hydrocarbon composition			
Aromatics, % volume	D 1319 (FIA)	28	35
Olefin	D 1319 (FIA)	Report	
Saturates	D 1319 (FIA)	Report	
Cetane Index	D 4737	42	48
Cetane Number	D 613	42	48
Copper Strip Corrosion	D 130		3
Flash Point, °C	D 92	54	
Cloud Point, °C	D 2500		-12
Pour Point, °C	D 97		-17
Carbon residue on 10 % residium, % weight	D 524		0.35
Water and sediment, % volume	D 2709		0.05
Ash, % weight	D 482		0.01
Viscosity, cSt at 40°C	D 445	2.0	3.0
Distillation, °C	D 86		
IBP		177	199
10 %		210	232
50 %		249	277
90 %		299	327
EP		327	360

A8. SPECIFIED UNITS AND FORMATS

A8.1 Specified Units:

A8.1.1 The parameters in this test method are specified in metric units except for pipe, pipe fittings, tubing, tubing fittings, and Compuccheck fittings. Pipe, pipe fittings, tubing, and tubing fittings are available worldwide and are not interchangeable with metric-sized equivalents because of differences in thread dimensions. Therefore, no metric conversion is stated. The Compuccheck fittings are diagnostic ports in the Cummins M11 engine block. The ports are standard straight thread and are not interchangeable with metric-sized equivalents.

A8.1.2 *Test Report*—Record operational parameters according to Table A8.1. Report test results in the units and with the significant digits shown in Table A8.2. Round test results in compliance with Practice E 29.

A8.1.3 *Measurements and Conversions*—With the exceptions noted in A8.1.1, all parameters have been specified in SI units. The intent of this test method is to measure all parameters directly in SI units. If parameters are measured in inch-pound units, then the laboratory shall be able to demonstrate to the TMC that the measurements are within the tolerance after conversion to SI units. (**Warning**—Significant error may occur due to rounding or tolerance stacking, or both, when converting from inch-pound units to SI units.)

A8.2 *Specification Format*—Specifications are listed in three formats: (1) target, (2) target and range, and (3) range with no target.

A8.2.1 *Target*—A target specification has no tolerance, therefore, the only acceptable value is the target. A representative specification format is xx.xx (target). For example, the oil pan oil charge is listed as 24.7 kg.

A8.2.1.1 A parameter with a target shall not be intentionally calibrated or controlled at a level other than the target.

A8.2.2 *Target and Range*—A target and a range specification implies the correct value is the target and the range is intended as a guide for maximum acceptable variation about the mean. A representative specification format is xx.xx ± x.xx (target ±

TABLE A8.1 Minimum Resolution of Recorded Measurements

Parameter	Record Data to Nearest
Speed	1 r/min
Power	1 kW
Torque	1 Nom
Fuel Flow	0.1 kg/h
Coolant In Temperature	0.1 °C
Coolant Out Temperature	0.1 °C
Fuel In Temperature	0.1 °C
Oil Gallery Temperature	0.1 °C
Intake Air Temperature	0.1 °C
Exhaust (Tailpipe) Temperature	1 °C
Intake Manifold Pressure	0.1 kPa
Crankcase Pressure	0.01 kPa
Exhaust Pressure	0.1 kPa

TABLE A8.2 Significant Digits for Test Results

Parameter	Round Off to Nearest
Crosshead Mass Loss	0.1 mg
Sludge	0.1 merit
Filter Plugging	1 kPa

range). For example, the engine speed is 1800 ± 5 r/min. (**Warning**—The mean of a random sample should be equivalent to the target. Operation within the range does not imply that parameter shall not bias the final test results.)

A8.2.3 Range with No Target—A range with no target specification is used when (1) the parameter is not critical and control within the range is sufficient or (2) the measurement technique is not precise, or both. A representative specification format is xx.xx – xx.xx (rangelow – rangehigh). For example, the coolant system pressure is 99 to 107 kPa.

A9. CUMMINS M11 HST REPORT FORMS AND DATA DICTIONARY

A9.1 Download the actual report forms and data dictionary separately from the ASTM Test Monitoring Center Web Page at <http://www.tmc.astm.cmri.cmu.edu/> or they can be obtained in hardcopy format from the TMC.

TABLE A9.1 List of Report Forms

1. Test Report Cover	Form 0
2. Test Summary—Non-Reference Oil Test	Form 1
3. Test Summary—Reference Oil Test	Form 1A
4. Operational Summary	Form 2
5. Crosshead Mass Loss Summary	Form 3
6. Oil Filter Delta Pressure Plot	Form 4
7. Sludge Rating Summary	Form 5
8. Rod Bearing Mass Loss	Form 6
9. Piston Rating Summary	Form 7
10. Piston 1 Deposit Ratings	Form 8
11. Piston 2 Deposit Ratings	Form 9
12. Piston 3 Deposit Ratings	Form 10
13. Piston 4 Deposit Ratings	Form 11
14. Piston 5 Deposit Ratings	Form 12
15. Piston 6 Deposit Ratings	Form 13
16. Ring Weight Loss Summary	Form 14
17. Oil Analysis Summary	Form 15
18. Test Fuel Analysis	Form 16
19. Unscheduled Downtime and Maintenance Summary	Form 17
20. Characteristics of the Data Acquisition System	Form 18

A10. SLUDGE RATING FORMS

A10.1 See Fig. A10.1 and Fig. A10.2.

A11. PISTON RATING LOCATIONS

A11.1 See Table A11.1.

TABLE A11.1 Piston Rating Locations

Location / Deposit	Special Instructions
Grooves	
Top Groove Fill	
Second Groove Fill	
Grooves No. 1, No. 3	Rate HC, MC, LC
Groove No. 2	Rate HC, LC
Lands	
Top Land Heavy Carbon	
Top Land % Flaked Carbon	
Lands No. 1 – No. 4	Rate HC, LC only
Other	
Oil Cooling Gallery	Rate separately from grooves and lands
Undercrown	Rate separately from grooves and lands

A12. OIL ANALYSES

A12.1 See Table A12.1.

TABLE A12.1 Oil Analyses

Sample Hour	Parameter				
	Metals ^A	TAN ^B	TBN ^C	Vis at 100 °C ^D	Soot ^E
0	X	X	X	X	X
25	X			X	X
50	X	X	X	X	X
75	X			X	X
100	X	X	X	X	X
125	X	X	X	X	X
150	X	X	X	X	X
175	X	X	X	X	X
200	X	X	X	X	X

^A Test Method D 5185 (Copper, Iron, Lead).

^B Test Method D 664.

^C Test Methods D 4739 and D 2896.

^D Test Methods D 5967 (Annex 3) or D 445.

^E Test Method D 5967 (Annex 4).

A13. OIL FILTER PLUGGING

A13.1 See Fig. A13.1 and Fig. A13.2.

A14. DETERMINATION OF OPERATIONAL VALIDITY

A14.1 *Quality Index Calculation:*

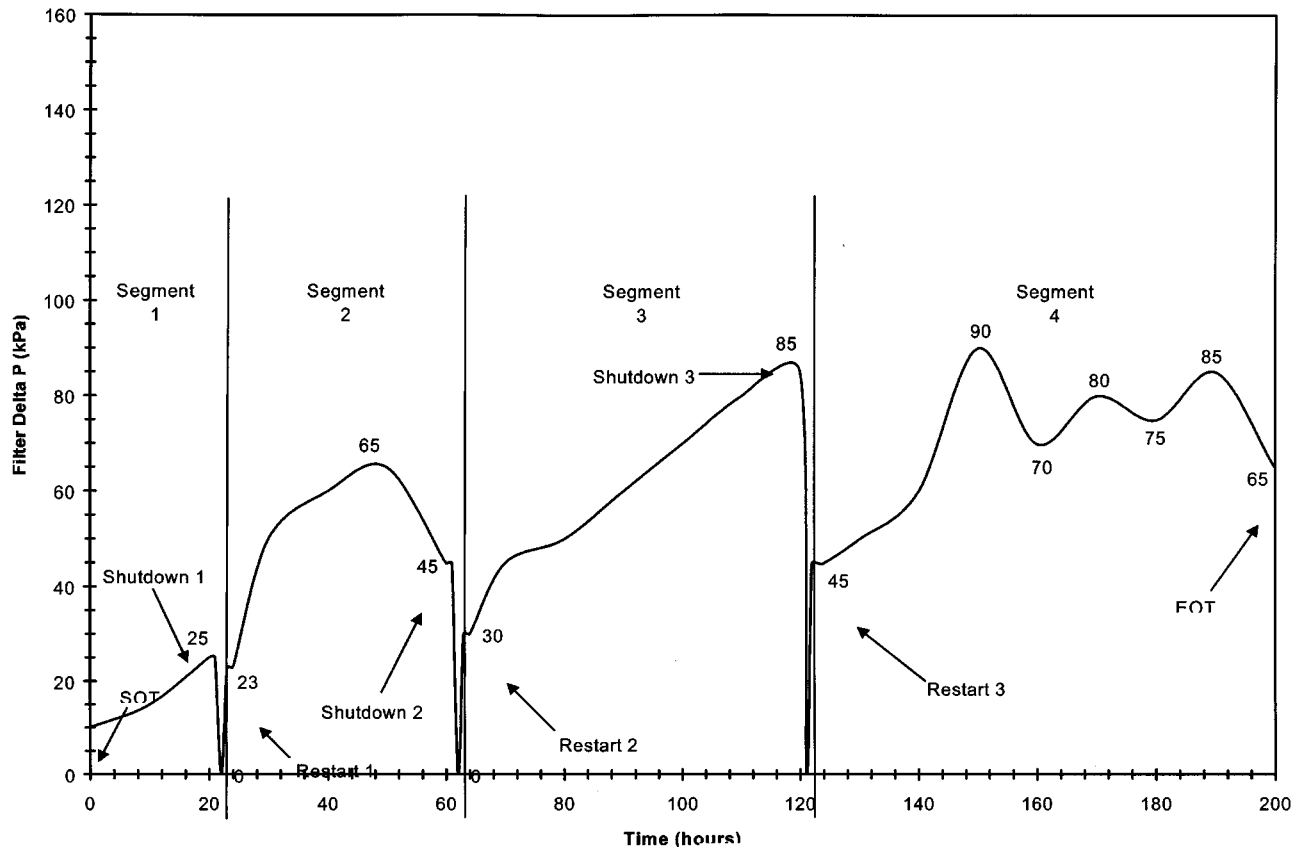

FIG. A13.1 Non-Adjusted Oil Filter Delta P

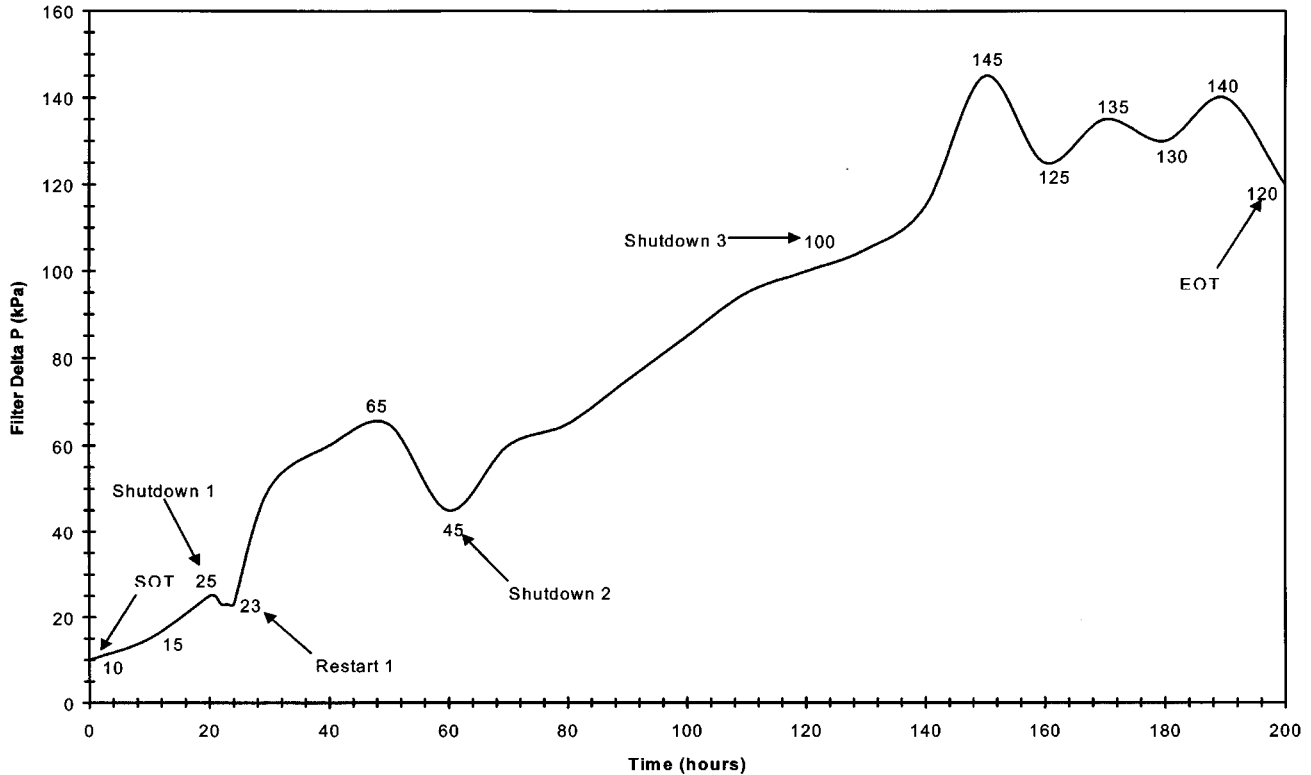

FIG. A13.2 Adjusted Oil Filter Delta P

A14.1.1 Calculate Quality Index (QI) for all control parameters according to the DACA II Report. Be sure to account for missing or bad quality data according to the DACA II Report as well.

A14.1.2 Use the U, L, Over Range, and Under Range values shown in Table A14.1 for the QI calculations.

A14.1.3 Round the calculated QI values to the nearest 0.001.

A14.1.4 Report the QI values on Form 2 shown in A9.1.

A14.2 *Averages* —Calculate the average for control and non-control parameters and report the values on Form 2 shown in Table A9.1. Note that the averages are not directly used to determine operational validity but they may be helpful when an engineering review is required (refer to A14.4).

A14.3 *Determining Operational Validity:*

A14.3.1 QI threshold values for operational validity are shown in Table A14.1.

A14.3.1.1 A test with all control parameter QI values greater than or equal to the threshold value is operationally valid.

A14.3.1.2 A test with any control parameter QI value less than the threshold value requires an engineering review to determine operational validity.

A14.4 *Engineering Review:*

A14.4.1 An engineering review is required when a control parameter QI value is below the threshold value. A typical engineering review involves investigation of the test data to determine the cause of the below threshold QI. Affected parameters

TABLE A14.1 Quality Index Calculation Values

Control Parameter	Units	Quality Index Threshold	Quality Index U and L Values				Over and Under Range Values	
			U	L	Low	High		
Speed ^A	r/min	0.000	1802.5	1602.5	1797.5	1597.5	1489	1911
Fuel Flow ^A	kg/h	0.000		53.5		52.5	31	75
Coolant Out Temp.	°C	0.000		89.0		87.0	44	132
Fuel In Temp.	°C	0.000		40.6		39.4	14	66
Oil Gallery Temp.	°C	0.000		115.7		114.3	84	146
Intake Manifold Temp.	°C	0.000		46.6		45.4	20	72
Exhaust Back Pressure	kPa	0.000		107.6		106.4	81	133

^A U and L values for speed are split by test stage.

may also be examined. This may be helpful in determining if a real control problem existed and the possible extent to which it may have impacted the test. For example, a test runs with a low QI for fuel flow. An examination of the fuel flow data may show that the fuel flow data contains several over range values. At this point, an examination of exhaust temperatures may help determine whether the instrumentation problem affected real fuel flow versus affecting only the data acquisition.

A14.4.2 For reference tests, the engineering review shall be conducted jointly with the TMC. For non-reference tests, optional input is available from the TMC for the engineering review.

A14.4.3 Determine operational validity based upon the engineering review and summarize the decision in the comment section on Form 17 listed in A9.1. It may be helpful to include any supporting documentation at the end of the test report. The final decision regarding operational validity rests with the laboratory.

APPENDIXES

(Nonmandatory Information)

X1. SUPPLIERS LIST

X1.1 Available from a Cummins parts distributor.

X1.2 Available from the CPD:

Test Engineering, Inc.
 12758 Cimarron Path, Suite 102
 San Antonio, TX 78249-3417
 Phone: (210) 690-1958
 Fax: (210) 690-1959

X1.3 The modified oil pan and the oil heat exchanger adapter blocks may be obtained from:

Southwest Research Institute
 P.O. Drawer 28510
 San Antonio, TX 78228
 Phone (210) 522-3567
 Fax (210) 522-5913

X1.4 The Moroso oil tank (P/N 22660) may be obtained from:

Moroso Performance Products Inc.
 80 Carter Dr.
 P.O. Box 1470
 Guilford, CT 06437
 Phone (203) 453-6571
 Fax (203) 453-6906

X2. TYPICAL SYSTEM CONFIGURATIONS

X2.1 See Figs. X2.1-X2.3.

ASTM International takes no position respecting the validity of any patent rights asserted in connection with any item mentioned in this standard. Users of this standard are expressly advised that determination of the validity of any such patent rights, and the risk of infringement of such rights, are entirely their own responsibility.

This standard is subject to revision at any time by the responsible technical committee and must be reviewed every five years and if not revised, either reapproved or withdrawn. Your comments are invited either for revision of this standard or for additional standards and should be addressed to ASTM International Headquarters. Your comments will receive careful consideration at a meeting of the responsible technical committee, which you may attend. If you feel that your comments have not received a fair hearing you should make your views known to the ASTM Committee on Standards, at the address shown below.

TABLE X1.1 Non-Kit Parts Available from the CPD

Description	Cummins P/N ^A	Critical Part
Cylinder Head	3084650	Y
Injector	3087557	Y
Turbocharger	3803710	Y
Timing Sensor	3078151	Y
Cam Shaft	3084568	Y
Gear Housing	3895536	Y

^A Available from a Cummins parts distributor.

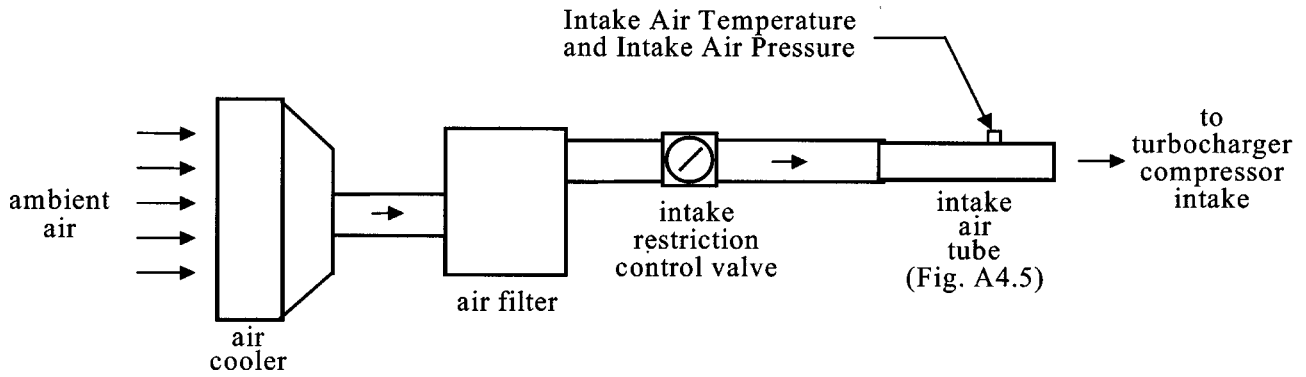
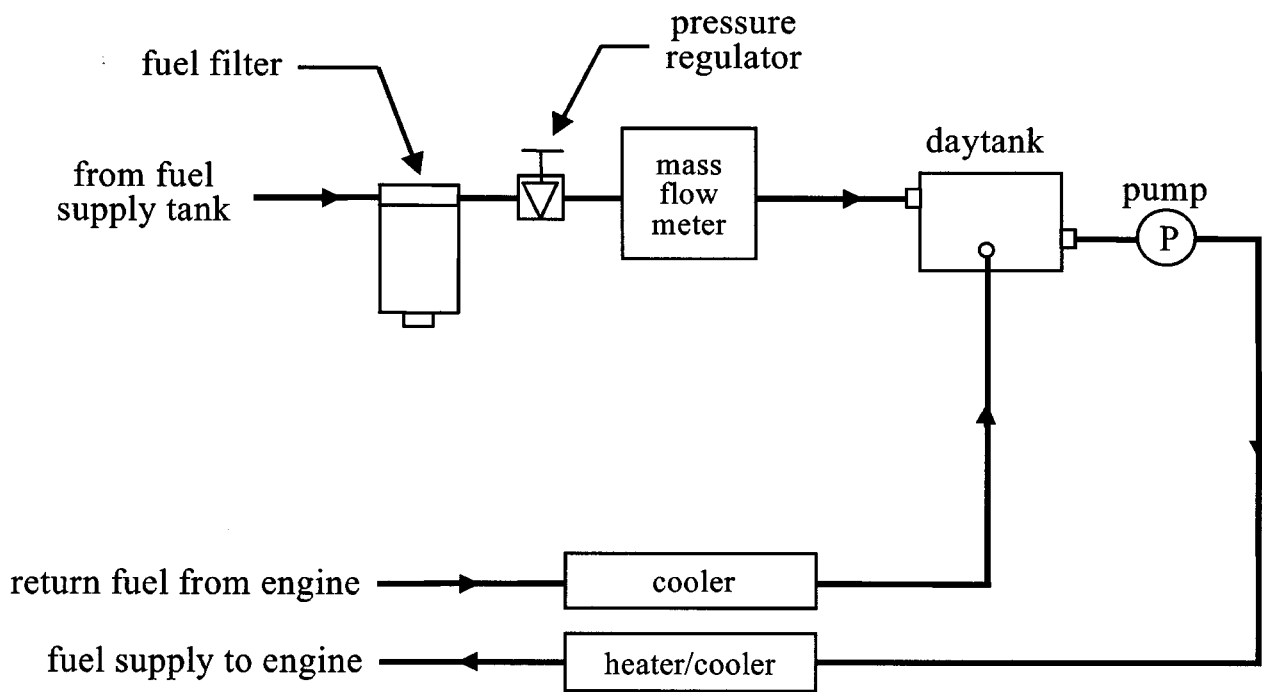

FIG. X2.1 Intake Air System



Heating or cooling, or both, may be necessary to maintain fuel temperature.

FIG. X2.2 Fuel System

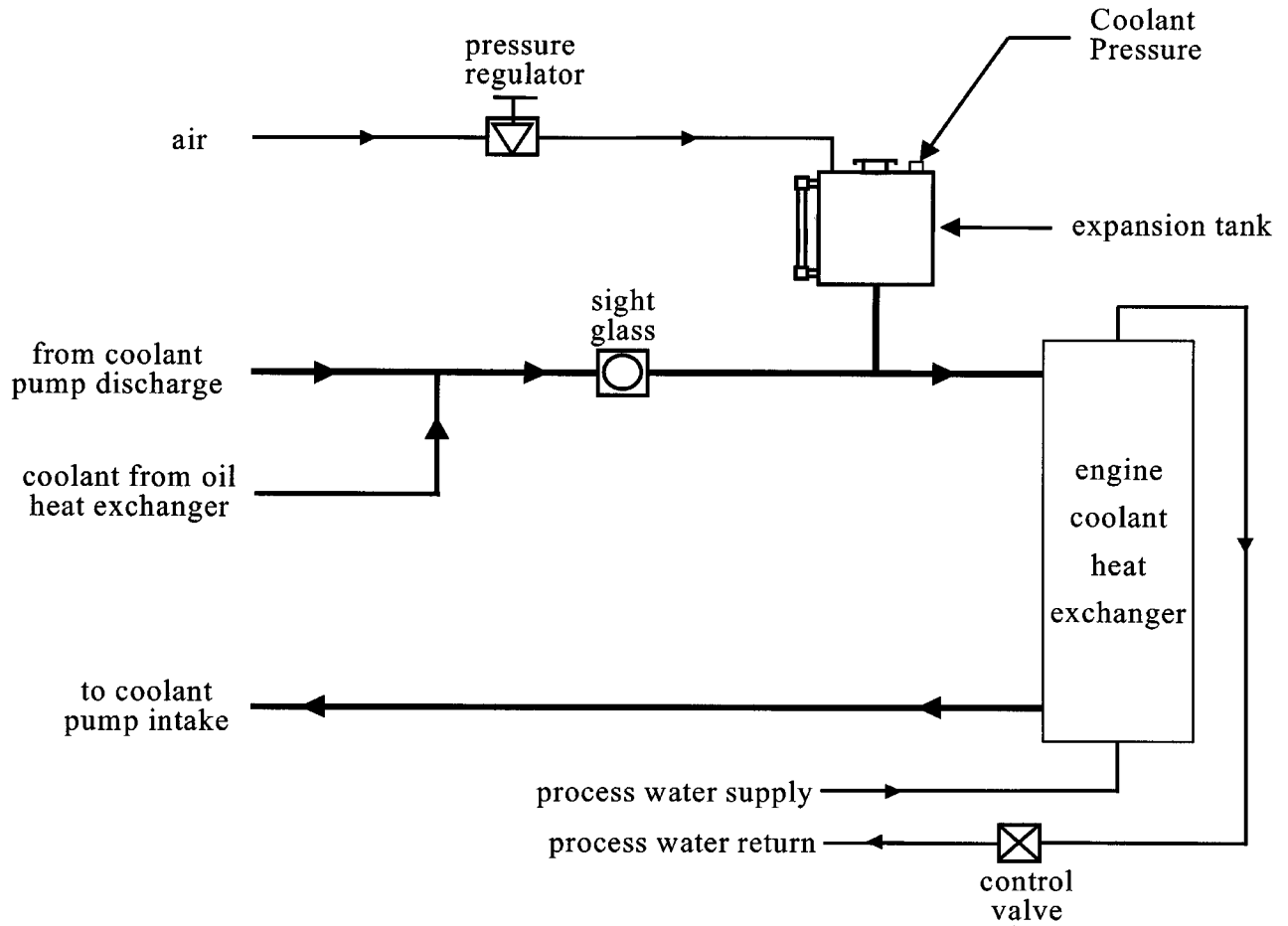

FIG. X2.3 Coolant System

This standard is copyrighted by ASTM International, 100 Barr Harbor Drive, PO Box C700, West Conshohocken, PA 19428-2959, United States. Individual reprints (single or multiple copies) of this standard may be obtained by contacting ASTM at the above address or at 610-832-9585 (phone), 610-832-9555 (fax), or service@astm.org (e-mail); or through the ASTM website (www.astm.org).