



Designation: D 1826 – 94 (Reapproved 1998)

Standard Test Method for Calorific (Heating) Value of Gases in Natural Gas Range by Continuous Recording Calorimeter¹

This standard is issued under the fixed designation D 1826; the number immediately following the designation indicates the year of original adoption or, in the case of revision, the year of last revision. A number in parentheses indicates the year of last reapproval. A superscript epsilon (ϵ) indicates an editorial change since the last revision or reapproval.

1. Scope

1.1 This test method covers the determination with the continuous recording calorimeter (Note 1) of the total calorific (heating) value of fuel gas produced or sold in the natural gas range from 900 to 1200 Btu/standard ft³.

NOTE 1—An extensive investigation of the accuracy of the Cutler-Hammer recording gas calorimeter, when used with gases of high heating value, was made by the National Bureau of Standards in 1957 under a research project sponsored by the American Gas Association.

1.2 The subjects covered in this test method appear in the following sections:

	Sections
Air-Gas Ratio Test	11
Apparatus	5
Basis of Measurement	14
Cold Balance Test	10
Compensation of Complicating Factors	13
Condition of Gas Sample	7
Definitions	2
Installation of Apparatus	6
Maintenance	Appendix X1
Operating Precautions	Appendix X2
Operation and Checking of Apparatus	9
Precision	15
Scope	1
Significance and Use	4
Standardization of Calorimeter	12
Standardization, Preliminary, of Calorimeter by Hydrogen	8
Summary of Test Method	3

1.3 *This standard does not purport to address all of the safety concerns, if any, associated with its use. It is the responsibility of the user of this standard to establish appropriate safety and health practices and determine the applicability of regulatory limitations prior to use.*

2. Terminology

2.1 Definitions of Terms Specific to This Standard:

2.1.1 The most important terms used in connection with the determination of the calorific value of gaseous fuels in recording calorimetry are as follows:

2.1.2 *British Thermal Unit, or Btu*—is the defined International Tables British thermal unit (symbol Btu).

NOTE 2—The defining relationships are:

(a) $1 \text{ Btu}\cdot\text{lb}^{-1} = 2.326 \text{ J}\cdot\text{g}^{-1}$ (exact)

(b) $1 \text{ lb} = 453.59237 \text{ g}$ (exact).

By these relationships, $1 \text{ Btu} = 1055.05585262 \text{ J}$ (exact). For most purposes, the value rounded to $1 \text{ Btu} = 1055.056 \text{ J}$ is adequate.

2.1.3 *combustion air*—air used for combustion, a total of the portion mixed with the gas as primary air and the air supplied around the burner tube as secondary air (theoretical air plus excess air).

2.1.4 *flue gases*—the products, of combustion remaining in the gaseous state, together with any excess air.

2.1.5 *heat-absorbing air*—the heat exchange medium used to absorb the heat of combustion derived from the burning of gaseous fuel.

2.1.6 *saturated basis*—the expressed total calorific value of a gas when it is saturated with water vapor at standard temperature and pressure; 1 ft^3 of this gas is equivalent in dry gas content to 0.9826 ft^3 of dry gas at the standard temperature of 60°F and standard pressure of 14.73 psia .

NOTE 3—The definitions given in 2.1.6 and 2.1.10 are for total calorific (heating) values per standard cubic foot of gas. The definitions corresponding to any other unit quantity of gas are obtained by substituting the name of the desired unit in place of the term “standard cubic foot” in the definitions. Methods of calculating calorific (heating) values per cubic foot of gas under any desired conditions of pressure, temperature, and water vapor content are specified in Section 14.

2.1.7 *standard cubic foot of gas*—the quantity of any gas that at standard temperature and under standard pressure will fill a space of 1 ft^3 when in equilibrium with liquid water.

2.1.8 *standard pressure*—is 14.73 psia .

NOTE 4—This is the pressure base adopted by the American National Standards Institute in 1969 (Z132.1). According to Dalton’s law, this is equivalent to stating that the partial pressure of the gas is:

$$14.73 - 0.25636 = 14.47364 \text{ psia}$$

where 0.25636 is the vapor pressure of water in psia at 60°F .

2.1.9 *standard temperature*— 60°F , based on the international practical temperature scale of 1968.

2.1.10 *total calorific value (gross heating value, higher heating value)*—of a gas is the number of British thermal units evolved by the complete combustion at constant pressure of

¹ This test method is under the jurisdiction of ASTM Committee D-3 on Gaseous Fuels and is the direct responsibility of Subcommittee D03.03 on Determination of Heating Value and Relative Density of Gaseous Fuels.

Current edition approved Feb. 15, 1994. Published April 1994. Originally published as D 1826 – 61 T. Last previous edition D 1826 – 88 (1993) ϵ 1.

one standard cubic foot of gas with air, the temperature of the gas, air, and products of combustion being 60°F, and all the water formed by the combustion reaction being condensed to the liquid state.

3. Summary of Test Method

3.1 The heating value is determined by imparting all of the heat obtained from the combustion of the test gas to a stream of air and measuring the rise in temperature of the air. The streams of test gas and heat absorbing air are maintained in fixed volumetric proportion to each other by metering devices similar to the ordinary wet test meters geared together and driven from a common electric motor. The meters are mounted in a tank of water, the level of which is maintained and the temperature of which determines the temperature of the entering gas and air.

3.2 The flue gas resulting from combustion of the gas (combustion products plus excess combustion air) is kept separate from the heat-absorbing air and is cooled to a few degrees above the initial temperature of gas and air. The water formed in the combustion is practically all condensed to the liquid state. Consequently, the temperature rise produced in the heat-absorbing air is directly proportional to the heating value of the gas. Since all the heat from the combustion of the test gas sample, including the latent heat of vaporization of the water vapor formed in the combustion, is imparted to the heat-absorbing air, the calorimeter makes a direct determination of total heating value. The temperature rise is measured by nickel resistance thermometers and is translated into Btu per standard cubic foot.

4. Significance and Use

4.1 This test method provides an accurate and reliable method to measure the total calorific value of a fuel gas, on a continuous basis, which is used for regulatory compliance, custody transfer, and process control.

5. Apparatus

5.1 The recording calorimeter (Note 5) consists of two major units; the tank unit or calorimeter proper, Fig. 1, Fig. 2, and Fig. 3, in which the heating value of the test gas sample is measured; and the recording unit which translates the heat

measurements into an indication of calorific (heating) value and records it graphically on a strip chart recorder or digitally if the new SMART-CAL is used (Note 6).

NOTE 5—The previous specified pressure base was the absolute pressure of a column of pure mercury 30 in. in height at 32°F and under standard gravity (32.174 ft/s²). This is equivalent to 14.7346 psia.

NOTE 6—Refer to specific manufacturer's manual for pictures of the recorder or the SMART-CAL, a digital indicating or printing device, currently used on new or retrofitted calorimeters.

6. Installation of Apparatus

6.1 To secure the precise results that are possible with the recording calorimeter, it is important that the instrument be installed so that the surrounding conditions will not introduce errors. In general, more precise results will be secured when a narrow range is maintained on the various conditions of the calorimeter environment.

6.2 *Calorimeter Room*—A typical installation of a single recording calorimeter is shown in Fig. 4. The detailed requirements for the calorimeter room are given in Table 1.

NOTE 7—A detailed discussion of these requirements is included in the latest edition of the manufacturer's instruction book covering the recording calorimeter. The information can be applied to all models of the instrument.

NOTE 8—The dimensions shown in Fig. 4 are for the latest model calorimeter.

6.3 *Gas Connection*—Locate the sample line that brings the gas to be tested to the calorimeter tank unit so that the heating value is actually representative of the conditions existing in the main gas line. Keep the sample line time lag as small as possible by (1) locating the calorimeter tank unit close to the sample point, (2) running the sample line of small size pipe (Note 9), and (3) operating the sample line at low pressure. Provide an additional purge burner or a bleed to a low pressure point.

NOTE 9—Time lag may be calculated on the basis that the calorimeter uses about 1.2 ft³/h.

6.4 *Electrical Wiring*—The four leads for the resistance thermometers between either the recorder or the Smart-CAL junction box and the tank unit shall be of No. 12 gage, insulated, solid copper wire without joints. Run in a separate rigid metal conduit which is grounded and contains no other

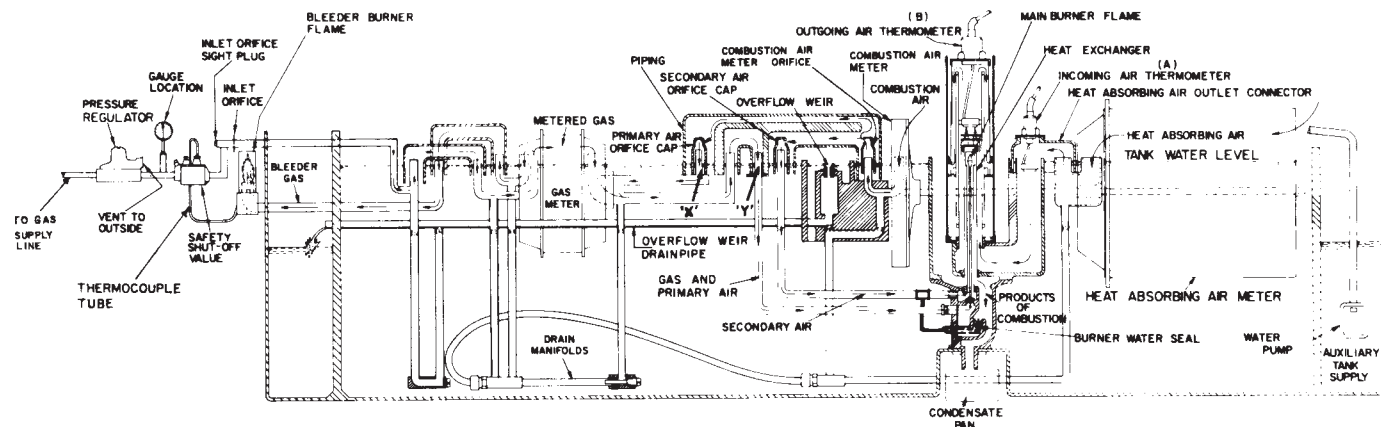

FIG. 1 Calorimeter—Schematic Flow Diagram

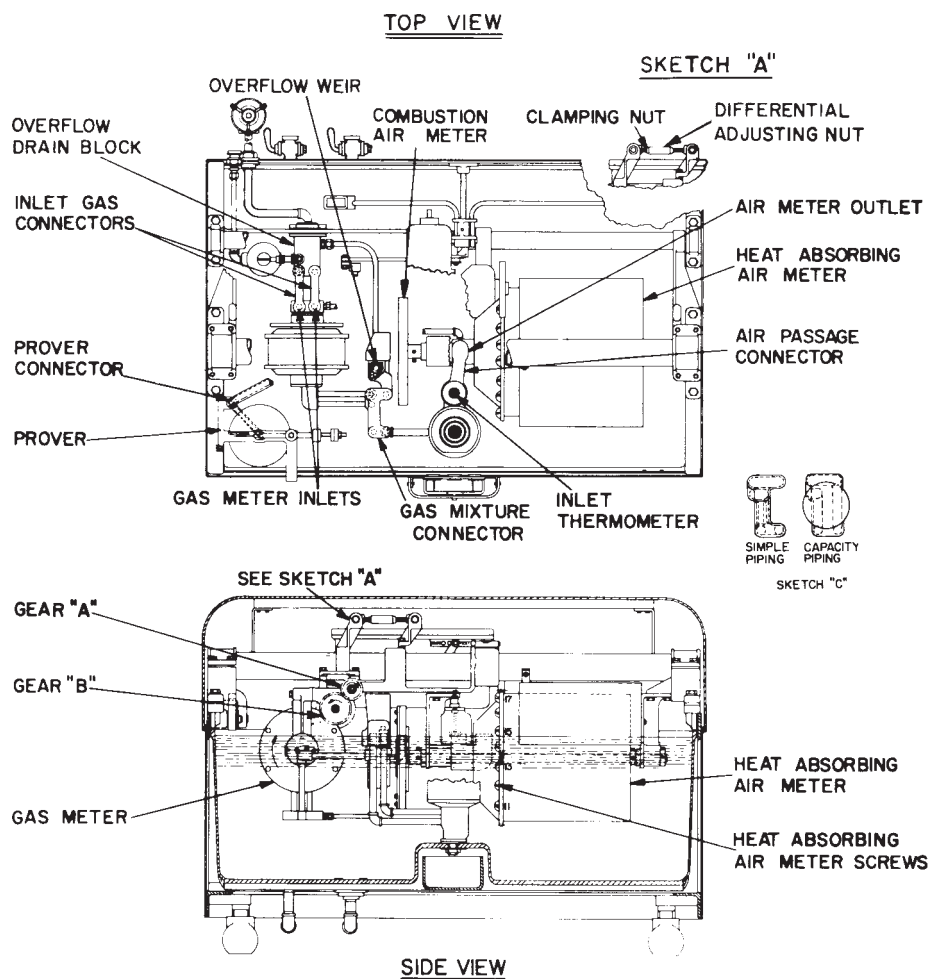

FIG. 2 Calorimeter—Layout Diagram

leads (Note 10). Power circuit wiring should be No. 14 gage, insulated, solid or stranded, copper wire. Provide the supply line with a suitably fused disconnect switch. For the model using an electronic recorder, it is essential that a suitable ground connection be made at both the recorder and the tank unit. Details are given in the manufacturer's instructions.

NOTE 10—Where outdoor or underground wiring must be used, special care should be exercised to protect the terminals of the cables from moisture to prevent grounds in the measuring circuit.

6.5 *Initial Installation*—When the calorimeter is first installed, fill the tank unit with water (Note 11) and adjust it to a temperature that is 2 to 5°F below the normal room temperature. Allow the unit to operate at least 24 h before performing the detailed calibration tests.

NOTE 11—The water may be ordinary tap water supplied by most municipalities. If, however, it is found that excessive quantities of deposits and sludge are formed in short duration which interfere with satisfactory performance, it will be necessary to use distilled or demineralized water with a pH of 7.

NOTE 12—For actual test instructions and other information, see the appropriate instruction book provided by the manufacturer.

6.6 *Recorder Installation*—Install the recorder so that the instrument is reasonably free from mechanical vibration. This

is particularly important for those models in which a suspension-type galvanometer is used.

7. Condition of Gas Sample

7.1 *Physical Contamination*—The gas sample should be free of dust, water, and other entrained solids. If experience indicates that the foreign materials can enter the sample line, install a suitable sample line filter. To avoid any problems in the line from water accumulation, pitch the line to a low point and provide a drip leg.

7.2 *Chemical Contamination*—The sample line should be practically free from hydrogen sulfide. A small, low-capacity purifier can be constructed using iron oxide on wood shavings as the purifying material. The time lag in the purifier adds to the sample line time lag so that the purifier should be of small capacity. A design that will purify about 3 ft³ of gas/h will be satisfactory.

8. Preliminary Standardization of Calorimeter by Hydrogen

8.1 The use of preliminary standardization by hydrogen test gas before the use of standard methane at the time of the initial installation or after any complete major overhaul of the tank unit and recorder is required, because of the following factors:

ASTM D 1826 – 94 (1998)

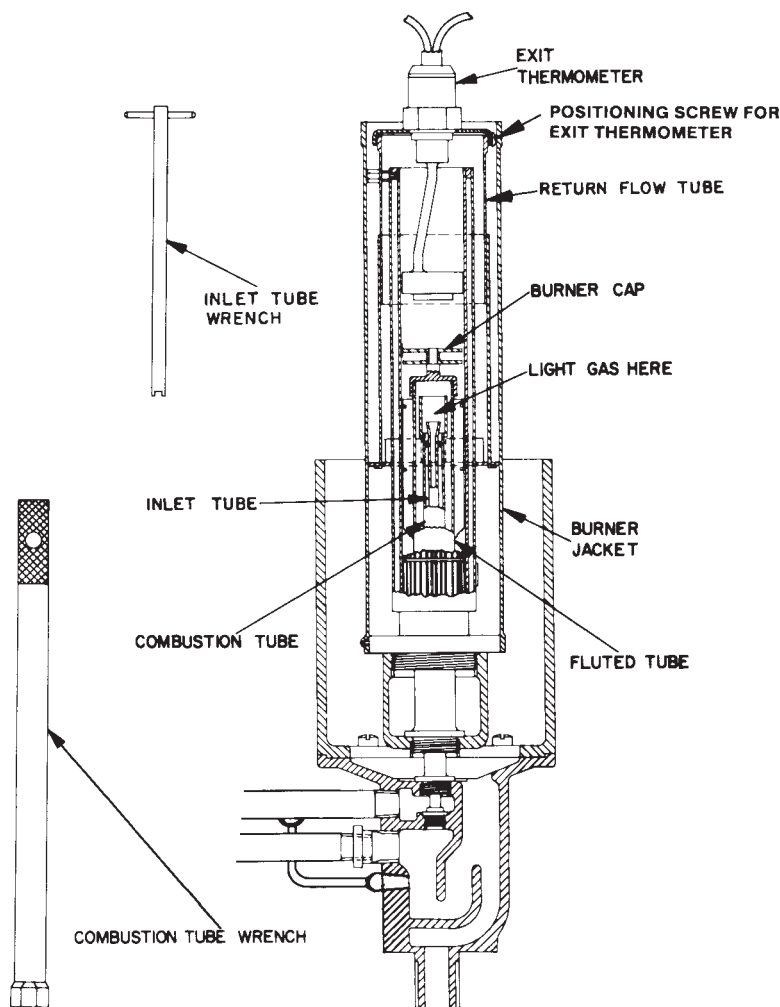

FIG. 3 Calorimeter Combustion Chamber

8.1.1 Because of the low density of hydrogen, the presence of any leaks in the system from the gas meter to the burner will result in a definite low reading. This situation should certainly be considered on the initial installation and whenever the gas meter assembly has been dismantled for inspection or cleaning.

8.1.2 The hydrogen test gives another cross-check of the slide wire and thermometer calibration at a different point on the scale of the instrument. A satisfactory hydrogen test gives additional assurance that no error exists in this part of the instrument.

8.1.3 There is practically no possibility of incomplete combustion on the hydrogen test. Therefore, a satisfactory hydrogen result gives assurance that, with the proper heat input, the correct calorific value reading will be secured. If a satisfactory hydrogen test has been secured and a low reading has been obtained on the standard gas, the possibility of incomplete combustion could be suspected. Without the hydrogen test, there might be some tendency to make adjustments to compensate in another way for the low reading. This is obviously undesirable.

NOTE 13—Use the manufacturer's instruction manual for the hydrogen test. This test is considered satisfactory if the reading agrees with the theoretical value within 0.3 %.

9. Operation and Checking of Apparatus

9.1 The recording calorimeter is designed for continuous operation and, as a precision instrument, it should receive regular inspection. Recording the results of tests, the replacement of any parts, and the establishment of a regular inspection will ensure that the high degree of precision attainable will be maintained. The manufacturer's appropriate instruction book gives details of the procedure for operating the instrument. The following points should be checked periodically:

9.1.1 *Recorder*—Check the operation of the recorder at regular intervals to be sure that the chart is set at the proper time and that the pen is making a satisfactory line. Examinations of the chart record will aid in avoiding certain operating problems since the record will show if undesirable conditions develop. For example, an irregular chart may be the result of deposits in the burner parts or on orifice caps. Gradual changes in the record from normal values may indicate a failure to replenish the water in the reserve tank or may show the existence of obstructions on the overflow weir.

9.1.1.1 *SMART-CAL*—The paper in the printer should be checked weekly. It may be necessary to correct the time. If alarm lights such as "high," "low," "max deviation," or "flame

ASTM D 1826 – 94 (1998)

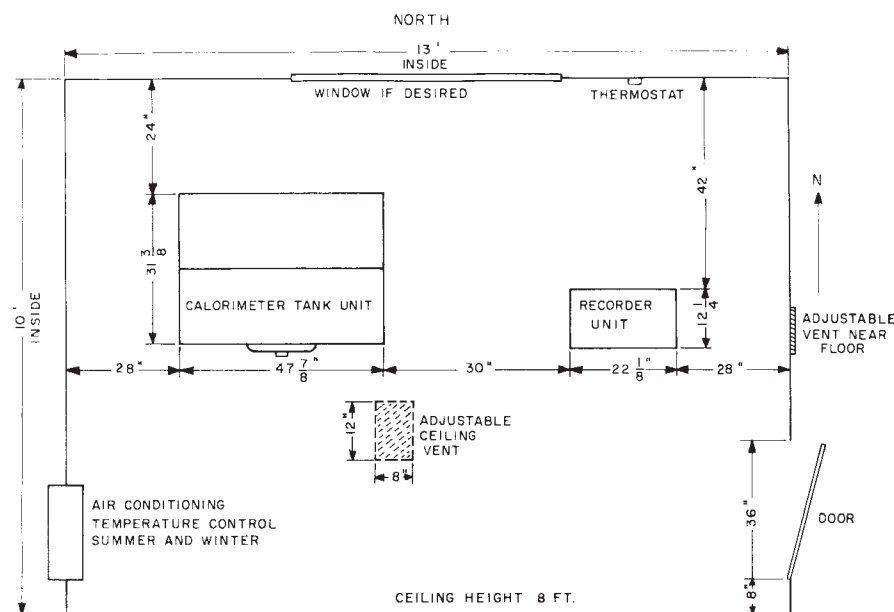

NOTE 1—For each additional calorimeter at least 50 % additional space is required; for example, for two calorimeters the room should be 12 by 18 ft inside; for three calorimeters 15 by 18 ft.

FIG. 4 Calorimeter Room

TABLE 1 Calorimeter Room Requirements

Detail	Requirements
Space	1000 ft. ³ min.
Ceiling height	8 ft, min.
Side wall widths	10 and 13 ft, min.
Windows	One, on side normally away from sun (in northern hemisphere, the northern side).
Doors	One, with 3-ft opening, not in window wall. A door check is desirable.
Ventilation	Natural ventilation using ceiling vent and a vent at floor level. Both should be located away from the tank unit.
Tank location	The tank unit should be in a draft-free location with respect to heating and cooling units and natural ventilation.
Heating and cooling	Controlled in the range 60 to 75°F with a variation of not more than 2.5°F from the set point.
Foundation floor	The calorimeter should remain level at all times. Design for 3000-lb static and dynamic load. The tank feet should be on load bearing parts of the floor.
Lighting	No direct sunlight permitted on calorimeter tank unit.
Condition of air	Essentially free from dust and absolutely free from any combustible gas for both measurement accuracy and safety. Trace hydrocarbons can be removed from combustion air using a Hoskins furnace and a combustion air meter hood.
Vibration	No vibrations or shocks shall be transmitted to the tank unit.
Water	Pure pH-7 clean water shall be available for filling the tank and replenishing the reserve tank.
Power supply	115 V, 1 phase, 60 Hz, 1000 W for small motors. Lighting, heating, and cooling in addition.
Gas supply	Sample pipe shall be 1/4-in. tubing. Pressure shall be cut at the pipeline to 1 1/2 to 2 psig for minimum time lag. Pressure at the calorimeter shall be 6 to 30 in. w.c.
Water supply and drain	Desirable but not essential.
Radiation	Tank unit shall be shielded from any hot radiation surfaces.
Safety	It should be remembered that the calorimeter has open flames. Natural ventilation is sufficient in nonhazardous locations and where only the aforementioned 1/4-in. tubing service for natural gas at 1 psig is used. Hydrocarbon vapor detectors and purging means should be considered for installations where location can be hazardous, where higher pressure gas is present, or where gases heavier than air are involved. In all installations, lighting installations should be suitable for Division I, and incoming power from underground services should have sealoffs.

out” are activated, the operator will check the tank unit for water level, flame out, dirty overflow weir, restricted combustion air flow, defective burner parts, and so forth.

9.1.2 *Tank Unit*—To avoid contamination of the air in the room with combustible gas, take care to ensure that the bleeder burner remains lighted at all times. For unattended locations, a thermostatically operated shutoff valve that closes upon failure of the bleeder flame is normally provided. Regular inspection will indicate the necessity of replenishing the water in the reserve tank and thus ensure maintenance of the proper level in the main tank. The presence of any foreign material either in or

on the water can be avoided by regular examination. This will prevent incorrect overflow weir operation. Periodic examination of the thermometers and the burner parts will avoid errors in reading which could be caused by deterioration of any of these parts.

10. Procedure for Cold Balance Test

10.1 *For the Recorder When Used:*

10.1.1 The object of the cold balance test is to check the complete temperature-measuring circuit. It is equivalent to the calorimeter measuring a gas with zero heating value. For this

test, observe the same precautions and care that are required for the calorimeter in normal use. The overall time of test shall not be less than 1 h.

10.1.2 If the cold balance is consistent within the range of the balancing rheostat (only small variations occurring from one test to another), the thermometer leads and resistance elements in the circuit are in satisfactory condition.

10.1.3 The rheostat provides a small amount of adjustment to compensate for any differences in the resistance of the thermometer leads. Thus, variations in the setting could be evidence of unsatisfactory electrical connections or deterioration of the thermometers or connecting leads.

10.1.4 When performing the test, it is very important that the room temperature be stable to avoid a false balance condition. In effect, a falling room temperature tends to result in a low-balance setting and a rising room temperature in a high-balance setting. The room temperature variation shall not exceed $\pm 2.5^{\circ}\text{F}$ during this test.

10.2 *For SMART-CAL When Used:*

10.2.1 The object of the cold balance test is to check the complete temperature measuring circuit and the electrical calibration of the SMART-CAL using internal test circuitry described in 10.2.2. This test is performed with the tank unit running. Stabilization time would be the same as specified in 10.1.1.

10.2.2 The cold balance and span adjustments are made when the SMART-CAL is in the calibration mode. Using the keyboard, the operator should activate the low-range display. This value is adjusted using the cold balance screw on front. Then the high-range display is activated. It is then set to the correct value using the span screw on the top of the instrument. The correct low- and high-range values are specified on a calibration plate on the front of the instrument. These values are a function of the heating value range, the thermometer pair used, and the basis of measurement.

11. Procedure for Air-Gas Ratio Test

11.1 The object of the air-gas ratio test is to ensure the fixed predetermined volume relation between the output of the gas meter and that of the heat-absorbing air meter. This volume ratio is a basic factor in the accuracy of the calorimeter.

11.2 The room temperature shall be reasonably constant at the normal controlled value during the test.

11.3 The tank unit shall be in proper mechanical operating condition; particularly, there should be no excessive gear or bearing wear existing.

11.4 Accurately balance the air-gas ratio prover. (See new model setup, Fig. 5.)

11.5 There shall be no leaks in the gas meter, heat-absorbing air meter, or the prover and its connections.

11.6 Check the tank unit level before the air-gas ratio test is started.

11.7 Recording of a typical air-gas ratio test is shown in Table 2 with the allowable tolerances.

12. Standardization of Calorimeter

12.1 The overall accuracy of the recording calorimeter may be checked by burning a gas of known heating value and comparing the results with this value. The total time of test shall not be less than 1.5 h. For natural gases having heating values in the range 900 to 1200 Btu/ft³ use standard methane of known accuracy between 0.5 and 0.9 Btu/ft³ (Note 14). The use of methane involves no change in the operation of the calorimeter, but merely a shift from the test gas to the standard gas. Thus, this eliminates the necessity of changing gears to compensate for chart reading and results in no water-level changes.

12.2 For accepted performance, calibrations should be made weekly as set up in Fig. 6. However, before this is performed, it is essential that the calorimeter and recorder be in proper operating condition and calibration be performed as close as possible to the water temperature of the tank as expected

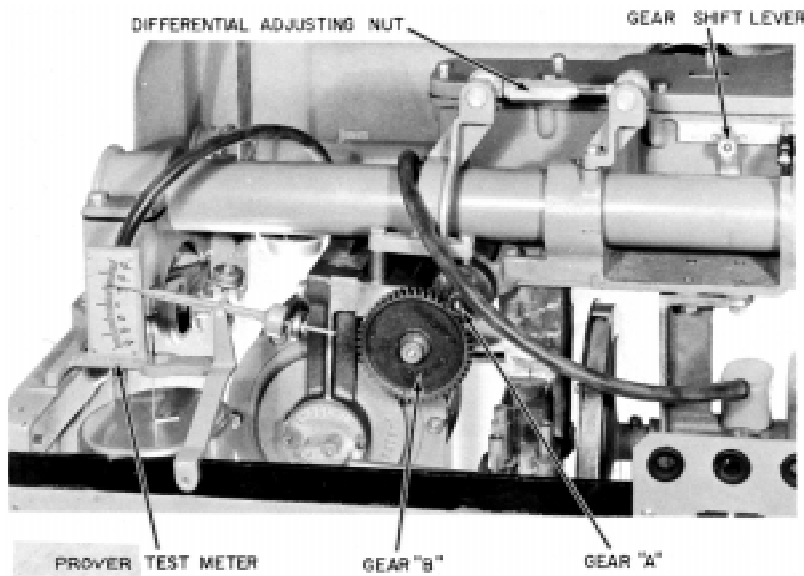

FIG. 5 Air-Gas Ratio Prover

TABLE 2 Typical Record of Air-Gas Ratio Test

Prover Readings for Beginnings and Endings of Air Meter Revolutions				Change in Prover Reading from Initial Reading			Average of One Revo- lution	
Starting Time:								
Screw Num- ber	Initial Read- ing	1st Complete Revolution	2nd Com- plete Revolu- tion	3rd Complete Revolution	Prover Readings of 1st, 2nd, 3rd Complete Revolutions Minus Initial Readings			Column VII Value Divided by 3
...	0	1	2	3	1-0	2-0	3-0	...
15	-0.01	-0.08	-0.15	-0.21	-0.07	-0.14	-0.20	-0.07
16	-0.02	-0.07	-0.13	-0.19	-0.05	-0.11	-0.07	-0.06
17	-0.03	-0.09	-0.16	-0.21	-0.06	-0.13	-0.18	-0.06
Final Average of Column VIII								-0.06
Column No	I	II	III	IV	V	VI	VII ^A	VIII ^B

^AIf any reading in Column VII exceeds $\pm 0.30\%$, adjust the air-gas ratio and repeat the test for the three complete revolutions.

^BThe averages in Column VIII should be less than $\pm 0.10\%$.

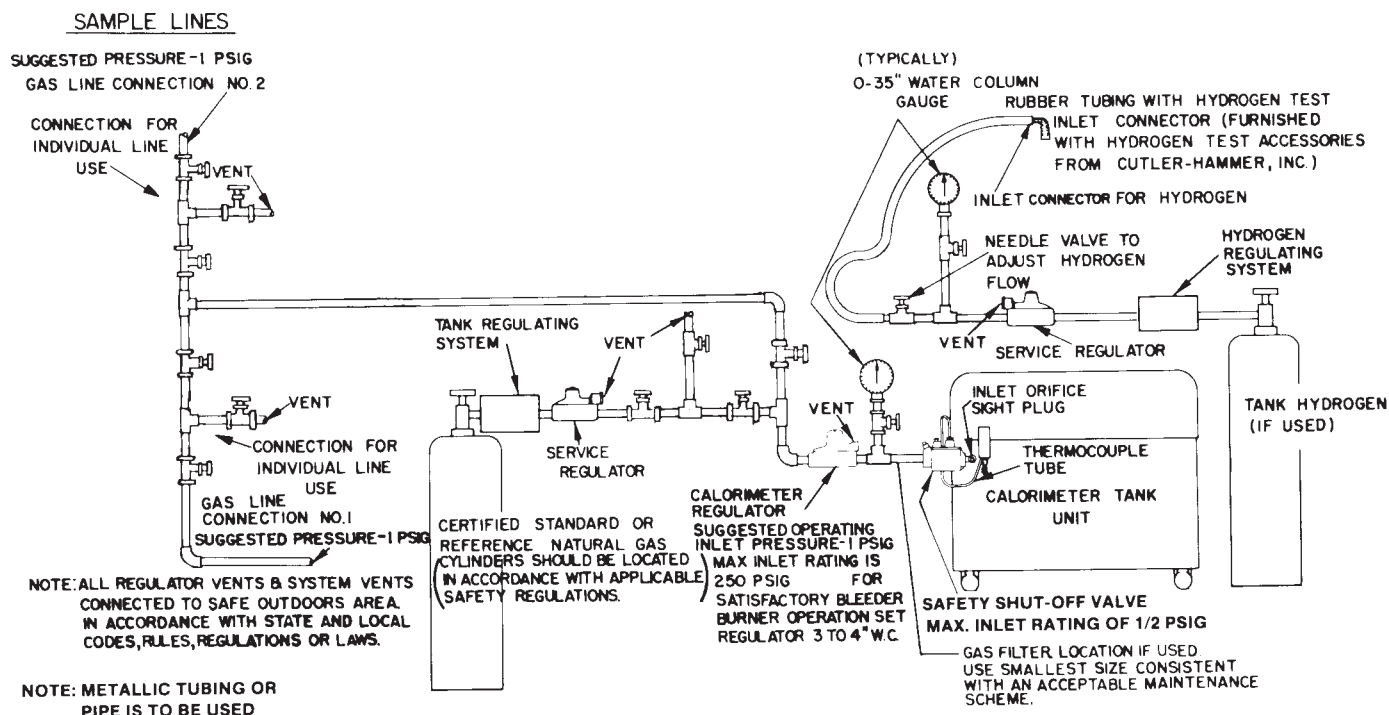

FIG. 6 Calorimeter Set Up for Calibration

during normal operation. The inlet pressure of the calibration gas shall be the same as for subsequent operation.

12.3 The SMART-CAL when used provides programmed automatic calibration. Thus the sample lines should use double block and bleed solenoid valves to insure representative sample reaching the calorimeter. The heating value of the test gas should be entered into the SMART-CAL program at the same basis of measurement as stated on the calibration plate. After subsequent calibrations, the SMART-Cal may detect a correction factor. This factor will be applied so a correct heating value is exhibited.

12.4 Manual calibration is used after overhaul or on startup. After the cold balance calibration in accordance with 10.2.1 and 10.2.2 is complete, the main burner should be lighted and allowed to stabilize in accordance with 12.1. The return flow tube may be adjusted for a zero error. Then the SMART-CAL will go on line with zero error.

NOTE 14—A standard gas, essentially methane, is supplied in high-pressure cylinders with certification of the heating value by the Institute of Gas Technology, 3424 S. State St., Chicago, IL 60616.

13. Compensation of Complicating Factors

13.1 Because the calorimeter chart reading is to be a direct indication of the heating value of the gas, compensation in the instrument must be made either by standardization or by mechanical devices for all correction terms and other complicating factors.

13.2 With a given initial temperature of gas and air, the temperature rise of the heat-absorbing air is directly proportional to the heat of combustion of the gas, but the resistance of the thermometers is a quadratic function of temperature. Hence, if the reading of the calorimeter is a linear function of thermometer resistance, it will not be a linear function of temperature, and therefore, it will not be a linear function of

heat of combustion. This effect can be compensated for by using a nonlinear scale of calorimeter reading versus resistance. In some Cutler-Hammer calorimeters, the scale of heating values extends from zero to a maximum reading, and the effect on calorimeter reading of the nonlinearity of the resistance-temperature relation is considerably reduced by using two linear resistance-reading scales, each extending over about half of the total range of the instrument. In some instruments, however, a more open (“expanded”) scale of heat of combustion is used, which covers only a limited range below the maximum, for example, the range from 900 to 1200 Btu/standard ft³. In more recent instruments, the scale is divided into a larger number of linear sections.

13.3 When the temperature of the tank and therefore the entering gas and air changes, the quantities of gas and air delivered by the meters change as a result of the thermal expansion of the gas and air, and also as a result of a change in partial pressure of the gas with change in the vapor pressure of water. The change in the quantity of gas delivered by the meter results in a change in the quantity of heat produced by combustion of gas per revolution of the gas meter, while the heat capacity of the air per unit volume is only slightly affected. Hence, if there were no compensating effect, a change in tank temperature would result in a change in reading of the calorimeter for a gas of a given heat of combustion. This effect is partially compensated for by the nonlinearity of the resistance-temperature relation of the thermometers. The compensation is not perfect, however, although it is very nearly so over the temperature range from 60 to 75°F. Outside this range, the reading on a gas of fixed heat of combustion changes rather rapidly with tank temperature.² Therefore, ideal conditions would be the maintenance of the temperature of the room by thermostatic control.

13.4 The gas and combustion air enter the calorimeter burner saturated with water vapor at the temperature of the tank, and the exit flue gases (product of combustion plus excess air) are also saturated with water vapor at the temperature to which they are cooled by the heat-absorbing air. Because of the contraction in volume which takes place when most gases are burned under conditions in which the water formed is condensed to the liquid state, the total volume of the flue gases will usually be less than that of the entering gas plus combustion air. Hence, if the flue gases were cooled to the temperature of the entering gas, more water vapor would be condensed than was formed in the combustion reaction and, consequently, the quantity of heat imparted to the heat-absorbing air would be greater than that corresponding to the total heating value of the gas, that is, corresponding to the condensation of only the water formed in combustion. This effect is partially eliminated by the fact that the burner and burner housing are so designed that the exit gases leave the calorimeter at a temperature somewhat higher than that of the entering gas and air, and therefore, carry off more water vapor than they would if cooled to the initial temperature of gas and air. The temperature at which the exit gas leaves the calorimeter can be varied by an

adjustment to the height of the return flow tube. The adjustment is made so that when using a calibrating gas only the water vapor from combustion is condensed. In practice, the height is adjusted until the calibrating value of the certified gas is indicated by the calorimeter. This adjustment is normally made when new burner parts are installed and only after all other adjustments have been rechecked. Note that most of the accompanying moisture comes from the saturated combustion air. Combustion air flow is up to 15 times that of the gas in the main burner. Once the jacket is set with the calibrating gas, the compensation should hold for all gases within the measurement span of the instrument. The amount of accompanying water is proportional to the tank water temperature, which changes slowly. Within the stated precision, a single calibrating gas with a heating value in the middle to upper 2/3 of the measurement span is sufficient. For optimum accuracy, the calibration gas should be selected to have a total calorific value within ± 50 Btu of the value to be measured.

13.5 *Barometric Pressure Variation*—A change in the reading for 1-in. Hg in barometric pressure is less than 0.01 % for any tank temperature between 60 and 90°F. However, calorimeters are adjusted as nearly as possible to the prevailing barometric pressure of the locality in which they are used.

13.6 *Relative Atmosphere Humidity*—This effect is eliminated because all the gases and air passing through the calorimeter are saturated with water vapor in the meters at the operating temperature.

13.7 *Bleeder Burner-Chimney Effect*—The bleeder burner of the calorimeter is located above the water level in the tank. Consequently, the gas pressure in the inlet chamber of the gas meter will vary dependent upon its height above the tank water. This difference in pressure is too small to affect the density of the gas appreciably, but it is large enough to have a significant effect on the water level in the meter and, therefore, the quantity of gas delivered by it per revolution. The effective height of the bleeder burner above the water tank has been set at 8½ in. (Note 15). Because the test gas and standard methane are of approximately the same density, the chimney effect is about the same for both gases and hence does not introduce any appreciable error into the reading of the test gas. It is important that the bleeder burner should not be piped to some other location, and the use of draft hoods or the like over the bleeder burner should be avoided.

NOTE 15—In the new model calorimeter, the bleeder burner opening is at the level of the tank water.

14. Basis of Measurement

14.1 The recording unit of the calorimeter is normally calibrated to give total heating value of the test gas directly in Btu per cubic foot at 14.73 psia, 60°F, saturated. The basis of measurement corresponds to the definition of a standard cubic foot of gas as contained in 2.1.7. However, variations have been introduced in an effort to make the basis of measurement correspond to average conditions existing in a specific system. The recording calorimeter can be calibrated to give results at any of these special bases of measurement by design of the recorder slide wire.

² This change is shown graphically in National Bureau of Standards Investigational Report, p. 19.

14.2 The design for a special base of measurement is based on the gas volume factor. This factor represents the number by which the heating value given in Btu per cubic foot at standard conditions of 14.73 psia, 60°F, saturated, must be multiplied to give results at the desired special base. The general equation can be written as follows:

$$F = \frac{(P - Vt)(60 + 459.7)}{(14.73 - 0.25636)(t + 459.7)} \quad (1)$$

where:

- F* = factor by which results at standard conditions of 14.73 psi, 60°F, saturated, must be multiplied to convert to the new pressure and temperature base;
- P* = total pressure of the cubic foot, psi;
- Vt* = vapor pressure of water at temperature *t*, psi;
- t* = temperature of the cubic foot, °F;
- 60 = standard temperature, °F;
- 459.7 = absolute temperature corresponding to 0°F; and
- 0.25636 = vapor pressure of water at 60°F, psi.

Typical factors that have been calculated from the equation are given in Table 3.

15. Precision

15.1 The reproducibility of three calorimeters was followed over a four-year period.³ The calorimeters were standardized

³ Eiseman, J. H., and Potter, E. A., "Accuracy of the Cutler-Hammer Recording Gas Calorimeter when used with Gases of High Heating Value," American Gas Association, April 1957.

TABLE 3 Factors to Multiply to Heating Value Given in Btu per Cubic Foot at Standard Conditions of 14.73 psia, 60°F, Saturated, to Give Result at a Special Base of Measurement

NOTE 1—*V_t* at 32°F = 0.088 72 psi
V_t at 60°F = 0.256 36 psi
V_t at 15°C = 0.247 38 psi

Special Base Condition	"Factor F"
14.4 psi, 60°F, dry	0.9949
14.65 psi, 60°F, saturated	0.9945
14.65 psi, 60°F, dry	1.0122
14.70 psi, 60°F, dry	1.0156
14.70 psi, 60°F, saturated	0.9979
14.80 psi, 60°F, saturated	1.0048
14.90 psi, 60°F, saturated	1.0117
14.90 psi, 60°F dry	1.0295
14.95 psi, 60°F, saturated	1.0152
15.025 psi, 60°F, dry	1.0381
15.20 psi, 60°F, saturated	1.0325
29.3-in. Hg ^A , 60°F, saturated	0.9766
30.0-in. Hg ^A , 60°F, saturated	1.0003
30.0-in. Hg ^A , 60°F, 15 % saturated	1.0154
30.0-in. Hg ^A , 32°F, saturated	1.0695
30.0-in. Hg ^A , 60°F, dry	1.0180
One standard atmosphere ^B , 60°F, dry	1.0154
One standard atmosphere ^B , 60°F, saturated	0.9976
One standard atmosphere ^B , 15°C, dry	1.0173
One standard atmosphere ^B , 15°C, saturated	1.0002

^AColumn of pure mercury at 32°F and under standard gravity (32.174 ft/s²).

^B101 325 Pa = 14.695 95 psi.

with methane weekly. A rigid control was maintained over the room temperature so that no errors were caused by a change in the tank water temperature. An analysis of the data indicated that one week after standardization about 95 % of the errors were less than 0.3 % with a few errors as high as 0.5 %. It is expected that errors greater than these may be found if the period between checking against the standard methane is greater than one week.

15.2 In general, therefore, when the apparatus is operated in accordance with the instruction manual under controlled conditions of temperature, and continues to operate at very close to the same temperature at which it was calibrated, the precision will probably be within 0.3 %. This is also based on industry wide performance over the past few years.

16. Different Ranges and Spans

16.1 When the recorder is used, range changes are accomplished by changing the gas meter drive gears. Ranges of 150, 300, 600, 900, 1200, 1500, 1800, 3000, and 3600 Btu can be obtained. No slidewire change is needed for these ranges if the basis of measurement is not changed, and if the BTU span is not changed. Spans of 50 to 100 % and 66 to 100 % are normally supplied. If calibrated on methane as a 1200-Btu instrument, the calorimeter will be in calibration at other ranges after the gears are changed. Primary and secondary air orifice changes may be necessary to get proper burning. A chart and scale factor can be applied when the proper scale and paper are not available.

16.2 SMART-CAL range changes also require gas meter gear changes. However 30 to 45 MJ, 750 to 1350 Btu, 900 to 1200 Btu, and 825 to 1125 Btu all use the same drive gears. 750 to 1500 Btu uses a different gear ratio. Each of these ranges use different software. The same software can be used if just the basis of measurement is changed. Then only new calibration numbers are required. These can be calculated by multiplying the old number by the ratio of the new factor/old factor. See 14.2 for factors. A new permanent calibration plate is recommended.

16.3 SMART-CAL standard software provides 1-, 8-, and 24-h averages. Special software has been provided for 15 min and hourly averaging for unique application.

17. Keywords

17.1 calorimeter; calorific value; gaseous fuels; natural gases

 **D 1826 – 94 (1998)**

APPENDIXES

(Nonmandatory Information)

X1. MAINTENANCE

X1.1 Refer to instrument manual for general, weekly, and four-month care and maintenance.

X2. OPERATING PRECAUTIONS

X2.1 Tank Unit

X2.1.1 Calibrate the instrument weekly.

X2.1.2 The inlet pressure used should be the same for both calibration and subsequent operation.

X2.1.3 Following the weekly care (see X1.1) will eliminate the following adverse conditions:

(1) Chemical reactions in some of the burner parts cause gradual accumulation of insulating compounds which affect absorption of heat.

(2) Dust from the air and gas tends to accumulate in the gas and air orifices and in the fins of the fluted tube.

(3) Physical particles of slime tend to accumulate in the several meters.

(4) The surface tension characteristics of the water at the weir can change causing some deleterious effect upon the efficiency of the instrument.

X2.2 Recorder Unit

X2.2.1 Sensitivity or response to small heating value changes can vary because of such things as excessive tolerances of moving parts, the fineness of adjustment of the resetting levers, the degree of tension in the suspension strips,

the presence of oil film or dust on the fiber pointer, imperfect contact with the slide wire, or the change in efficiency of the rectifier.

X2.2.2 Also, variations in the humidity of the room as well as improper tolerances on the adjustment of the rolls can cause differences in agreement between the scale and chart, amounting to as much as 2 Btu.

X2.2.3 For any specific summation of all such effects upon the recorded heating value, the cold balance rheostat or the baffle in the burner jacket can be changed in a direction that will cause the pen on the properly aligned chart to indicate a heating value in agreement with the heating value of the calibrating gas. However, no change greater than 0.15 % shall be attempted. But even when the calibration is in progress or during any subsequent time interval, slight changes in some of the mentioned factors can bring about a somewhat different summation of effects.

X2.2.4 Some instruments use an electronic recorder which utilizes an electronic amplifier and a servomotor to position the pen and pointer. The gain of the amplifier should be turned up to a level so that the servomotor pinion oscillates just enough to adsorb the backlash between the pinion and associated ball gear. The balancing slidewire should be cleaned with an eraser and brushed free of any particles.

ASTM International takes no position respecting the validity of any patent rights asserted in connection with any item mentioned in this standard. Users of this standard are expressly advised that determination of the validity of any such patent rights, and the risk of infringement of such rights, are entirely their own responsibility.

This standard is subject to revision at any time by the responsible technical committee and must be reviewed every five years and if not revised, either reapproved or withdrawn. Your comments are invited either for revision of this standard or for additional standards and should be addressed to ASTM International Headquarters. Your comments will receive careful consideration at a meeting of the responsible technical committee, which you may attend. If you feel that your comments have not received a fair hearing you should make your views known to the ASTM Committee on Standards, at the address shown below.

This standard is copyrighted by ASTM International, 100 Barr Harbor Drive, PO Box C700, West Conshohocken, PA 19428-2959, United States. Individual reprints (single or multiple copies) of this standard may be obtained by contacting ASTM at the above address or at 610-832-9585 (phone), 610-832-9555 (fax), or service@astm.org (e-mail); or through the ASTM website (www.astm.org).