



Designation: D 1857 – 87 (Reapproved 2000)

Standard Test Method for Fusibility of Coal and Coke Ash¹

This standard is issued under the fixed designation D 1857; the number immediately following the designation indicates the year of original adoption or, in the case of revision, the year of last revision. A number in parentheses indicates the year of last reapproval. A superscript epsilon (ϵ) indicates an editorial change since the last revision or reapproval.

1. Scope

1.1 This test method covers the observation of the temperatures at which triangular pyramids (cones) prepared from coal and coke ash attain and pass through certain defined stages of fusing and flow when heated at a specified rate in controlled, mildly reducing, and where desired, oxidizing atmospheres.

1.2 The test method is empirical, and strict observance of the requirements and conditions is necessary to obtain reproducible temperatures and enable different laboratories to obtain concordant results.

1.3 The values stated in inch-pound units are to be regarded as the standard.

1.4 *This standard does not purport to address all of the safety concerns, if any, associated with its use. It is the responsibility of the user of this standard to establish appropriate safety and health practices and determine the applicability of regulatory limitations prior to use.*

2. Referenced Documents

2.1 ASTM Standards:

- D 2013 Method of Preparing Coal Samples for Analysis²
- D 3174 Test Method for Ash in the Analysis Sample of Coal and Coke from Coal²

3. Terminology

3.1 Definitions of Terms Specific to This Standard:

3.1.1 The critical temperature points to be observed are as follows, denoting the atmosphere used:

3.1.2 *fluid temperature, FT*—the temperature at which the fused mass has spread out in a nearly flat layer with a maximum height of $\frac{1}{16}$ in. (1.6 mm) as shown by the fifth cone, FT, in Fig. 1.

3.1.3 *hemispherical temperature, HT*—the temperature at which the cone has fused down to a hemispherical lump at which point the height is one half the width of the base as shown by the fourth cone, HT, in Fig. 1.

3.1.4 *initial deformation temperature, IT*—the temperature at which the first rounding of the apex of the cone occurs. Shrinkage or warping of the cone ignored if the tip remains

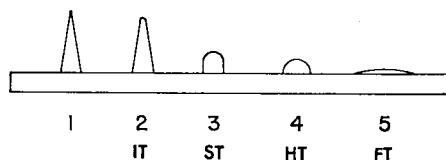

FIG. 1 Critical Temperature Points

sharp. In Fig. 1, the first cone shown is an unheated one; the second cone IT is a typical cone at the initial deformation stage.

3.1.5 *softening temperature, ST*—the temperature at which the cone has fused down to a spherical lump in which the height is equal to the width at the base as shown by the third cone, ST, in Fig. 1.

4. Significance and Use

4.1 Design of most coal combustion and coal conversion equipment anticipates that the ash either remain solid or assume some degree of fluidity, depending on the particular design. Ash fusibility temperatures predict whether the ash will perform properly in the process for which the coal was chosen.

5. Apparatus and Materials

5.1 *Furnace*—Any gas-fired or electric furnace conforming to the following requirements may be used:

5.1.1 Capable of maintaining a uniform temperature zone in which to heat the ash cones. This zone shall be such that the difference in the melting point of $\frac{1}{2}$ -in. (12.7-mm) pieces of pure gold wire when mounted in place of the ash cones on the cone support shall be not greater than 20°F (11°C) in a reducing atmosphere test run.

5.1.2 Capable of maintaining the desired atmosphere surrounding the cones during heating. The composition of the atmosphere, reducing or oxidizing, shall be maintained within the limits specified in Section 6. The desired atmosphere in the gas-fired furnace surrounding the cones shall be obtained by regulation of the ratio of gas to air in the combustion mixture. The desired atmosphere in the electric furnace shall be obtained by means of gases introduced into the heating chamber. The muffle shall be gas impervious, free from cracks, and the closure plug tight fitting. The gas supply tube shall be sealed to the back wall of the preheating chamber and shall not extend to the front of the preheating chamber against the perforated baffle.

5.1.3 Capable of regulation so that the rate of temperature rise shall be $15 \pm 5^\circ\text{F}$ ($8 \pm 3^\circ\text{C}$)/min.

¹ This test method is under the jurisdiction of ASTM Committee D05 on Coal and Coke, and is the direct responsibility of D05.21 on Methods of Analysis.

Current edition approved Feb. 10, 1987. Published April 1987. Originally published as D 1857 – 61 T. Last previous edition D 1857 – 68 (1980)*¹.

² *Annual Book of ASTM Standards*, Vol 05.06.

5.1.4 Providing means of observing the ash cones during the heating. Observation on the same horizontal plane as the cone-support surface shall be possible.

5.2 *Cone Mold*—A commercially available cone mold as shown in Fig. 2. The cone shall be $\frac{3}{4}$ in. (19 mm) in height and $\frac{1}{4}$ in. (6.4 mm) in width at each side of the base which is an equilateral triangle. A steel spatula with a pointed tip, ground off to fit the cone depression in the mold, is suitable for removal of the ash cone.

5.3 *Optical Pyrometer or Thermocouple*, for temperature measurements, conforming to the following requirements:

5.3.1 *Optical Pyrometer*—An optical pyrometer of the disappearing filament type shall be used. The instrument shall have been calibrated to be accurate within 20°F (11°C) up to 2550°F (1400°C) and within 30°F (16°C) from 2550 to 2900°F (1400 to 1600°C) (Note 1). The pyrometer filament shall be sighted on the cones until the softening point temperature *C* (Fig. 1) has been passed, and then sighted on the cone support. The pyrometer shall have readable graduations not larger than 10°F (5.5°C).

NOTE 1—The pyrometer equipment shall be standardized periodically by a suitably equipped standardizing laboratory such as that of the National Bureau of Standards, or checked periodically against equipment certified by the Bureau of Standards.

5.3.2 *Thermocouple*—A thermocouple of platinum and platinum-rhodium, protected from the furnace gases by a glazed porcelain sheath, shall be used with a high-resistance millivoltmeter or potentiometer accurate and readable to within 10°F (5.5°C). The sheath shall be sealed to the furnace wall by alundum cement. The hot junction of the thermocouple shall touch the end of the sheath and shall be located in the center of the muffle and immediately to the rear of the cones. The thermocouple protective sheath shall be checked periodically for cracks. The thermocouple and its meter shall meet the

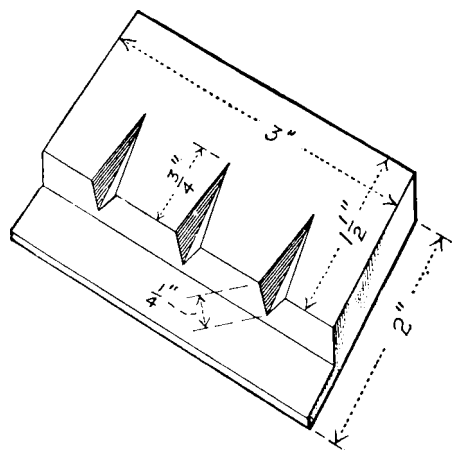

Inch-pound Units, in.	SI Units, mm
$\frac{1}{4}$	6.4
$\frac{3}{4}$	19.1
$1\frac{1}{2}$	38.1
2	50.2
3	76.2

FIG. 2 Brass Cone Mold

requirements of Section 9. The potentiometer or millivoltmeter shall be so located or adequately shielded as to prevent radiant and convection heating of the cold junction. The room temperature compensator shall be adjusted to the existing temperature.

5.4 *Ash-Cone Refractory Support*—The ash cones shall be mounted on a refractory base composed of a mixture of equal parts by weight of kaolin and alumina conforming to the following requirements:

5.4.1 *Kaolin*—NF-grade powder passing a No. 200 (75- μ m) sieve.

5.4.2 *Aluminum Oxide*—Reagent grade ignited powder passing a No. 100 (150- μ m) sieve.

5.5 *Refractory Support Mold*—A mold with flat top and bottom surfaces to provide a refractory support of suitable thickness to minimize warping. A sidemold not over $\frac{1}{4}$ in. (6.4 mm) high of any convenient shape, placed on an iron plate so that the top surface of the refractory mix can be struck off flat and parallel to the base by means of a straightedge, is satisfactory. For electric furnace use, legs not over $\frac{1}{8}$ in. (3 mm) long may be provided on the corners of the cone support by suitable holes bored in the iron base plate of the mold.

5.6 *Gold Wire*³—Twenty-four gage (0.51-mm diameter) or larger round wire of 99.98 % purity, but drawn from metal of 99.99 % purity, and having a melting point of 1945°F (1063°C).

5.7 *Nickel Wire*⁴—Twenty-four gage (0.51-mm diameter) or larger round wire of CP nickel, 99.98 % pure, fully annealed, and having a melting point of 2645°F (1452°C).

6. Test Atmosphere

6.1 *Gas-Fired Furnace:*

6.1.1 *Reducing Atmosphere Test*—A mildly reducing atmosphere surrounding the cones shall be maintained during the test in the gas-fired furnace. Hydrogen, hydrocarbons, and carbon monoxide shall be considered as reducing gases; oxygen, carbon dioxide, and water vapor shall be considered as oxidizing gases. Nitrogen is inert. The ratio by volume of reducing gases to oxidizing gases in the atmosphere shall be between the limits of 20 to 80 and 80 to 20,⁵ that is, on a nitrogen-free basis, the total amount of reducing gases present shall be between the limits of 20 and 80 volume %. A flame 6 to 8 in. (152 to 203 mm) in height and tinged with yellow above the furnace outlet has been found to provide an atmosphere within the specified limits.

6.1.2 *Oxidizing Atmosphere Test*—An atmosphere containing a minimum amount of reducing gases shall be maintained surrounding the cones during the test in the gas-fired furnace. On a nitrogen-free basis, the volume of reducing gases present in the atmosphere shall not exceed volume 10 %. Combustion with the maximum possible quantity of air with preservation of

³ Gold wire of this purity can be purchased from the Baker Dental Division of Engelhard Industries, Inc., 850 Passaic Ave., East Newark, NJ 07029 or from Leico Industries, Inc., 250 W. 57th St., New York, NY 10019.

⁴ Nickel wire of this purity can be purchased with the additional specification of having a minimum coefficient of resistance for 0 to 100°C of 0.006 73 $\Omega/\Omega\cdot^{\circ}\text{C}$, from Leico Industries, Inc., 250 W. 57th St., New York, NY 10019.

⁵ For information concerning the effect of various atmospheres, see U.S. Bureau of Mines *Bulletin 129*, 1918.



the specified rate of temperature increase has been found to provide an atmosphere within the specified limits. A completely blue flame, not over 2 in. (50 mm) in height above the outlet at the beginning of the test, provides the desired atmosphere; and, by regulation of the combustion gas-air ratio, the specified atmosphere and temperature rise can be maintained.

6.2 Electric Furnace:

6.2.1 *Reducing Atmosphere Test*—A regulated flow of gas of the nominal composition, 60 % carbon monoxide and 40 ± 5 volume % carbon dioxide,⁶ shall be maintained in the heating chamber throughout the test (Note 2) in the electric furnace. The gas stream shall be regulated by any convenient means to provide a measured flow of 1.3 to 1.5 furnace volumes per minute.

6.2.2 *Oxidizing Atmosphere Test*—A regulated stream of air shall be maintained throughout the test in the electric furnace. The gas stream shall be regulated by any convenient means to provide a measured flow of 1.3 to 1.5 furnace volumes per minute.

NOTE 2—Before using new cylinders of CO/CO₂ reducing gas, the contents should be mixed according to the gas manufacturer's recommendations. To assure that the gas remains mixed, the temperature of the cylinder contents should be maintained above the critical temperature at which CO₂ can liquify and separate.

7. Preparation of Ash

7.1 Use coal or coke passing a No. 60 (250- μ m) sieve prepared in accordance with Method D 2013, to obtain the ash by incineration in a well-ventilated muffle furnace. The quantity of coal or coke required will vary with the ash content; usually 3 to 5 g of ash will be sufficient for cones for several check determinations, if necessary. Spread out the coal or coke in a layer not over 1/4 in. (6.4 mm) in depth in a fireclay or porcelain roasting dish. Place the dish in the cold muffle or on the hearth at a low temperature and gradually heat to redness at such a rate as to avoid mechanical loss from too rapid expulsion of volatile matter (Note 3). Complete the conversion to ash at a temperature of 1470 to 1650°F (800 to 900°C). Transfer the ash to an agate mortar (Note 4) and grind it so that it will pass a No. 200 (75- μ m) sieve. Then spread the ash in a thin layer in a fireclay, silica, or porcelain dish and ignite it in a stream of oxygen for 1 1/2 h at 1470 to 1560°F (800 to 850°C) to ensure complete and uniform oxidation of the ash. Any tube or muffle-type furnace which, when supplied with an oxygen flow of not less than one furnace volume in 5 min, will maintain a highly oxidizing atmosphere and will be suitable.

NOTE 3—A heating rate conforming to that used for the ash determination specified in Section 7 of Test Method D 3174 is satisfactory.

NOTE 4—A mechanical agate mortar grinder will save time where many determinations are made. An iron mortar or pestle must not be used.

8. Preparation of Cones

8.1 Thoroughly mix the ignited ash in a mechanical mixer or on a sheet of glazed paper or oil cloth by raising first one corner to roll the ash over and then raising each of the other

corners in rotation in the same manner until each corner has been raised five times or more.

8.2 Take sufficient ash for the number of cones desired from various parts of the bulk ash. Moisten the ash with a few drops of a clear, filtered (if necessary) 10 % solution of dextrin containing 0.1 % salicylic acid as a preservative and work it into a stiff plastic mass with a spatula. Press the plastic material firmly with a spatula into the cone mold to form the triangular pyramids. Strike off the exposed surfaces of the material smooth and remove the cones from the mold by applying pressure at the base with a suitably pointed spatula. Previous coating of the mold with a thin layer of petroleum jelly, thinned with kerosene (if necessary), aids in preventing adherence of the cones to the mold and in providing the sharp point and edges desired in the cone. With certain coal ashes, cones with sharp points and edges can be obtained using distilled water in place of the dextrin solution and without the use of petroleum jelly.

8.3 Place the cones in a suitable location to dry sufficiently to permit handling without deformation. Mount the dried cone vertically on a freshly prepared refractory base. Moisten a portion of the well-mixed kaolin-alumina mixture with the minimum amount of water to make a workable, but stiff, plastic mass, and firmly press it into the support mold. Strike off the surface of the mass flat and smooth with a steel spatula, moistening with one or two drops of water if necessary to obtain a smooth surface. A number of cones may be mounted on one base. Make shallow triangular depressions, not over 1/32 in. (0.8 mm) in depth, with a triangular file ground to the correct size to produce a depression to fit the base of the cone, and locate the cones sufficiently distant from adjacent cones so that no merging of the fusing material of the cones shall occur during the test. Mount the cones vertically in the depressions while the base is still wet without the use of ash or refractory as a mounting aid (Note 5 and Note 6).

NOTE 5—The intent of the triangular depression is to enable the cones to be mounted in a sufficiently stable manner to permit handling of the prepared support with cones.

NOTE 6—Gold wires can be mounted on each cone support beside the ash cones, and the gold melting point observed concurrent with the ash cones in both oxidizing and reducing atmospheres.

8.4 For the calibration check run of Section 9, mount 1/2-in. (12.7-mm) lengths of gold and nickel wire, as described in 5.6 and 5.7, vertically on a support similar to those prepared as described in 8.3, but on which no ash cones are mounted, and by inserting the pieces of wire into the support before drying. Two or more pieces of each kind of wire should be mounted on this support in locations that correspond to ash cone positions. Dry the support as described in 8.5, but do not ignite. At least one such support with mounted pieces of gold and nickel wire shall be prepared for each week of observation of ash fusibility.

8.5 Dry the mounted cones and ignite to remove all carbonaceous material.

NOTE 7—If no organic material has been used in the preparation of the mounted cones, this ignition step may be omitted. The drying step must be retained.

9. Calibration Check

9.1 At least once during each week of operation, check the

⁶ This gas is available from the Matheson Gas Co., Inc.



optical pyrometer or the thermocouple and its meter for calibration in place under routine test conditions with the reducing atmosphere, by observations of the melting point of gold. At the same time, check the adequacy of the furnace atmosphere by observing the melting point of nickel.

9.1.1 Insert a support with mounted pieces of gold and nickel wire into the test furnace. Locate at the position used for tests of ash cones.

9.1.2 Establish the reducing gas atmosphere and heat the furnace chamber in accordance with 10.1.

9.1.3 Observe the temperatures shown on the meter when the pieces of wire melt.

9.1.4 The indicated melting points should be within $\pm 10^\circ\text{F}$ (5.5°C) of the following:

Gold	1945°F (1063°C)
Nickel	2645°F (1452°C)

9.1.5 If the indicated melting point for gold wire frequently falls outside of the desired range, readjust or recalibrate the meter so that the average temperature from several observations of the gold melting point is within the specified range.

9.1.6 If the indicated melting point for nickel wire frequently falls outside the desired range, after applying the corrections as described in 9.1.5, the consistency of indicated temperatures and the subsequent appearance of the specimen should be examined closely. Erratic readings or failures to obtain melting at 2645°F (1452°C) can be due to nickel oxidation caused by an insufficiently reducing atmosphere. If a consistent error of more than 25°F (14°C) is found, the furnace atmosphere and the temperature measurement equipment should be suspected of having faults; necessary corrections should be made.

10. Procedure

10.1 Reducing Atmosphere Test:

10.1.1 Place the mounted test cones in the furnace at a temperature of not over 1470°F (800°C) for the gas-fired furnace and not over 750°F (400°C) for the electric furnace to provide sufficient time to purge the air from the uniform temperature zone and establish the desired atmosphere.

10.1.2 If the furnace temperature is below the respective temperature specified in 10.1.1, raise it rapidly to the specified temperature; then control the rate of heating to give a rate of temperature increase of $15 \pm 5^\circ\text{F}$ ($8 \pm 3^\circ\text{C}$)/min. Maintain this rate throughout the test.

10.1.3 Establish the mildly reducing atmosphere surrounding the cones, as specified in 6.1.1 or 6.2.1, at the temperature specified in 10.1.1 for the respective furnace type. Maintain this atmosphere throughout the test.

NOTE 8—At temperatures of the order of 2500 to 2600°F (1370 to 1430°C) and above in the gas-fired furnace, it may not be possible to maintain the reducing gases above the 20 volume % limit specified while also preserving the specified rate of temperature increase. At such temperatures, the effect of the atmosphere is not so critical as the maintenance of the specified heating rate. Every effort shall be made to maintain the reducing gases as near the 20 % by volume level as possible at such temperatures.

10.1.4 Oxidizing Atmosphere Test:

10.1.4.1 Place the mounted test cones in the furnace at a temperature of not over 1470°F (800°C) for the gas-fired furnace and not over 750°F (400°C) for the electric furnace. If the furnace temperature is below the respective temperature specified, raise it rapidly to the specified temperature, then control the rate of heating to give a rate of temperature increase of $15 \pm 5^\circ\text{F}$ ($8 \pm 3^\circ\text{C}$)/min. Maintain this rate throughout the test.

10.1.4.2 Establish the oxidizing atmosphere surrounding the cones, as specified in 6.1.2 or 6.2.2 at the temperature specified in 10.1.4.1 for the respective furnace type. Maintain this atmosphere throughout the test.

11. Precision

11.1 *Repeatability (Single Operator and Apparatus)*—For each point, the difference for the critical point temperature between two separate furnace runs shall not exceed 50°F (30°C).

11.2 *Reproducibility (Different Operators and Apparatus)*—For each point, the difference for the critical point temperature between two furnace runs shall not exceed the following:

	°F	°C
For reducing atmosphere:		
Initial deformation temperature, IT	125	70
Softening temperature, ST	100	55
Hemispherical temperature, HT	100	55
Fluid temperature, FT	150	85
For oxidizing atmosphere:		
Initial deformation temperature, IT	100	55
Softening temperature, ST	100	55
Hemispherical temperature, HT	100	55
Fluid temperature, FT	100	55

ASTM International takes no position respecting the validity of any patent rights asserted in connection with any item mentioned in this standard. Users of this standard are expressly advised that determination of the validity of any such patent rights, and the risk of infringement of such rights, are entirely their own responsibility.

This standard is subject to revision at any time by the responsible technical committee and must be reviewed every five years and if not revised, either reapproved or withdrawn. Your comments are invited either for revision of this standard or for additional standards and should be addressed to ASTM International Headquarters. Your comments will receive careful consideration at a meeting of the responsible technical committee, which you may attend. If you feel that your comments have not received a fair hearing you should make your views known to the ASTM Committee on Standards, at the address shown below.

This standard is copyrighted by ASTM International, 100 Barr Harbor Drive, PO Box C700, West Conshohocken, PA 19428-2959, United States. Individual reprints (single or multiple copies) of this standard may be obtained by contacting ASTM at the above address or at 610-832-9585 (phone), 610-832-9555 (fax), or service@astm.org (e-mail); or through the ASTM website (www.astm.org).