



# Standard Practice for Preparing Coal Samples for Analysis<sup>1</sup>

This standard is issued under the fixed designation D 2013; the number immediately following the designation indicates the year of original adoption or, in the case of revision, the year of last revision. A number in parentheses indicates the year of last reapproval. A superscript epsilon (ε) indicates an editorial change since the last revision or reapproval.

## 1. Scope

1.1 This practice<sup>2</sup> covers the reduction and division of gross or divided samples up to and including the individual portions for laboratory analysis.

1.2 Reduction and division procedures are prescribed for coals of the following groups:

1.2.1 *Group A* includes coals that have been cleaned in all sizes.

1.2.2 *Group B* includes all other coals. Unknown coals are to be considered under Group B.

1.2.3 Group A allows smaller weight laboratory samples to be retained than Group B. These lower weights may be used for particular coals if they have been shown, by using the procedures of Annex A1.2, to give a sample preparation and analysis variance which is no more than 20 % of the total analysis variance.

1.3 *This standard does not purport to address all of the safety concerns, if any, associated with its use. It is the responsibility of the user of this standard to establish appropriate safety and health practices and determine the applicability of regulatory limitations prior to use.*

1.4 The values stated in SI units are to be regarded as standard. The values given in parentheses are provided for information purposes only.

## 2. Referenced Documents

### 2.1 ASTM Standards:

D 121 Terminology of Coal and Coke<sup>3</sup>

D 197 Test Method for Sampling and Fineness Test of Pulverized Coal<sup>3</sup>

D 2234 Practice for Collection of a Gross Sample of Coal<sup>3</sup>

D 3174 Test Method for Ash in the Analysis Sample of Coal and Coke from Coal<sup>3</sup>

D 3302 Test Method for Total Moisture in Coal<sup>3</sup>

D 4749 Test Method for Performing the Sieve Analysis of Coal and Designating Coal Size<sup>3</sup>

<sup>1</sup> This practice is under the jurisdiction of ASTM Committee D05 on Coal and Coke and is the direct responsibility of Subcommittee D05.23 on Sampling.

Current edition approved Oct. 10, 2000. Published January 2001. Originally published as D 2013 – 62 T. Last previous edition D 2013 – 00.

<sup>2</sup> For more detailed explanation of this practice see Keller, G. E., "Determination of Quantities Needed in Coal Sample Preparation and Analysis," *Transactions*, Vol 232, 1965, pp. 218-226.

<sup>3</sup> *Annual Book of ASTM Standards*, Vol 05.06.

E 11 Specification for Wire-Cloth Sieves for Testing Purposes<sup>4</sup>

E 177 Practice for Use of the Terms Precision and Bias in ASTM Test Methods<sup>4</sup>

E 456 Terminology Relating to Quality and Statistics<sup>4</sup>

## 3. Terminology

3.1 *Definitions of Terms Specific to This Standard*—No terms are used which are specific to this practice. Many terms used in this practice may be found in Terminologies D 121 and E 456 and in Practice E 177.

## 4. Summary of Practice

4.1 Three processes of sample division and reduction are covered as follows:

4.1.1 *Procedure A*—Manual riffles are used for division of the sample and mechanical crushing equipment for the reduction of the sample.

4.1.2 *Procedure B*—Mechanical sample dividers are used for the division of the sample and mechanical crushing equipment for the reduction of the sample.

4.1.3 *Combined Procedure A and B*—The two procedures may be combined at any stage.

## 5. Significance and Use

5.1 Other standards are used to collect the gross sample: Practice D 2234 allows for one division of the gross sample before crushing. The mass and top size of the gross or divided sample collected by using these guides and practices are usually too large for chemical or physical testing. Practice D 2013 provide instructions for reducing and dividing the gross or divided sample, by on-line or off-line processes, or both, to a top size and mass suitable to the performance of testing. Any bias in the gross or divided sample before adherence to this practice will remain in the final sample resulting from use of this practice. Therefore, carefully select the standard to be used to collect the gross sample.

5.2 Division and reduction of a sample may occur at more than one location. Most often, the sample is collected, reduced, and divided (one or more times) by use of a mechanical sampling system. The remaining sample may be further divided on-site to facilitate transporting it to the laboratory where further reduction and division likely occurs before analysis.

<sup>4</sup> *Annual Book of ASTM Standards*, Vol 14.02.

5.3 In places, this practice requires air drying the sample before subsequent reduction. Procedures for air drying and air-dry loss determination are provided in Test Method D 3302.

5.4 Most often, samples are reduced and divided to an analysis sample. However, some tests may require a sample of different mass or top size. This procedure may be used to provide a sample of any mass and size consist from the gross or divided sample to, and including, the analysis sample.

## 6. Apparatus

6.1 *Crushers or Grinders*—Jaw, cone, or rotary crusher; hammer mill; roll; or other suitable crusher to reduce the sample to pass the sieve designated in 6.4. Hard steel or chilled iron plate with tamper, sledge, or hand bar may be used for preliminary crushing of any large lumps in the sample before feeding into the crusher. Crushers should be designed and operated in a manner to minimize the effect of induced air circulation and thus the potential for drying the coal.

6.1.1 *Pulverizer or Mill*—For final reduction of laboratory sample to the 250- $\mu\text{m}$  (No. 60) sieve size, the following equipment may be used:

6.1.2 *Hammer Mill*—Completely enclosed to avoid loss of dust or moisture.

6.1.3 *Porcelain-Jar Ball Mill*—This mill shall be approximately 230 mm (9.0 in.) in diameter and 250 mm (10.0 in.) in height with smooth, hard, well-rounded, flint pebbles, or equivalent, that do not increase ash content of the sample.

6.1.4 *Bucking Board (Chrome Steel) or Mortar (Agate or Equivalent) and Pestle*—Only for reducing the small fraction of sample, not passing a 250- $\mu\text{m}$  (No. 60) sieve after pulverization.

### 6.2 Sample Dividers:

6.2.1 *Mechanical*—A mechanical sample divider using a reciprocating or rotating cutter, a rotating hopper and spout, a rotating slotted cone, a reciprocating hopper and fixed cutter, bucket cutter with either bottom dump or inverting discharge, slotted belt, rotary disk divider, mechanical stopped or moving belt sweeper, or other acceptable devices for dividing the sample. Typical mechanical sample dividers are shown in Fig. 1. These illustrate various designs, but other acceptable designs are available.

6.2.2 *Riffle*—A manual sample divider that splits the coal stream into a number of alternate elements. Riffle slots should be at least three times the top size of coal being divided. A typical riffler is shown in Fig. 2. It is preferable that feed chutes and enclosed riffles be used. The slope of feed chutes and riffles must be at least 60°.

6.2.2.1 *Feed Scoop*—A feed scoop or pan having straight sides and a width equal to the effective width of the riffle shall be used to feed the riffle.

6.2.2.2 *Feed Chute*—A feed chute shall be used as shown in Fig. 3. The minimum discharge opening of the feed chute shall be the same width as the riffle slot opening.

6.3 *Mixing Wheel*—One type of a mechanical device used for mixing the analysis sample. In this device, the samples are in closed containers attached to the rim of a wheel at an angle of 45° with the horizontal wheel shaft. The wheel provides space for a number of containers depending on its diameter and is turned slowly by a small motor and reduction gear. The

wheel should be rotated at a speed so that the particles fall gently from top to bottom of the container, mixing the sample thoroughly. The container should be about half full and never more than two thirds full to obtain good mixing of the sample.

6.4 *Sieves*—A set of sieves whose dimensions are in accordance with Specification E 11, of the following sizes, with cover and receiver:

No.	Size
4	4.75 mm
8	2.36 mm
20	850 $\mu\text{m}$
60	250 $\mu\text{m}$

6.5 *Laboratory Sample Containers*—Heavy vapor-impervious bags, properly sealed, or noncorroding cans such as those with an airtight top, friction top, or screwtop sealed with a rubber gasket and pressure-sensitive tape for use in storage and transport of the laboratory sample. Glass containers, sealed with rubber gaskets, may be used, but care must be taken to avoid breakage in transport.

## 7. Precautions

7.1 *General*—The preparation of the gross or divided sample shall be performed by, or under the direct supervision of, personnel knowledgeable of proper sample handling practices. Sample preparation should be checked at intervals by the methods described in Annex A1 or Annex A2. It is necessary that the variance of sample division and analysis  $S_{da}^2$  be not more than 20 % of the total variance of sampling, division, and analysis  $S_o^2$ .

7.1.1 The sample preparation operations should be performed in an enclosed space, roofed, cool, and free from excessive air movements.

7.2 *Number of Tests*—Before preparing the gross or divided sample, the number and nature of the analysis and tests should be considered. A separate moisture laboratory sample may be required, and portions may be required for grindability and other tests. Also, a reserve sample may be desired in case a check analysis or test is required.

7.3 This practice specifies situations when air drying the sample is necessary during sample preparation. Test Method D 3302 specifies procedures for air drying and calculation of percent air dry loss.

7.3.1 Calculate and record air-dry loss determination each time air drying is performed.

7.3.2 In handling, reducing, and dividing the sample, all operations shall be done rapidly and in as few operations as possible, since moisture loss depends on several factors other than total moisture content, such as time required for crushing, atmospheric temperature and humidity, and type of crushing equipment.

7.3.3 While awaiting preparation, the gross or divided sample shall be protected from moisture change as a result of exposure to rain, snow, wind, and sun on contact with absorbent materials.

7.3.4 Whenever subsamples are stored or transported, the containers and subsample shall be weighed and equilibrated to the new atmosphere by air drying, and the weight loss or gain shall be used in the calculation of moisture content.

7.4 Whenever a distinct change of humidity occurs during

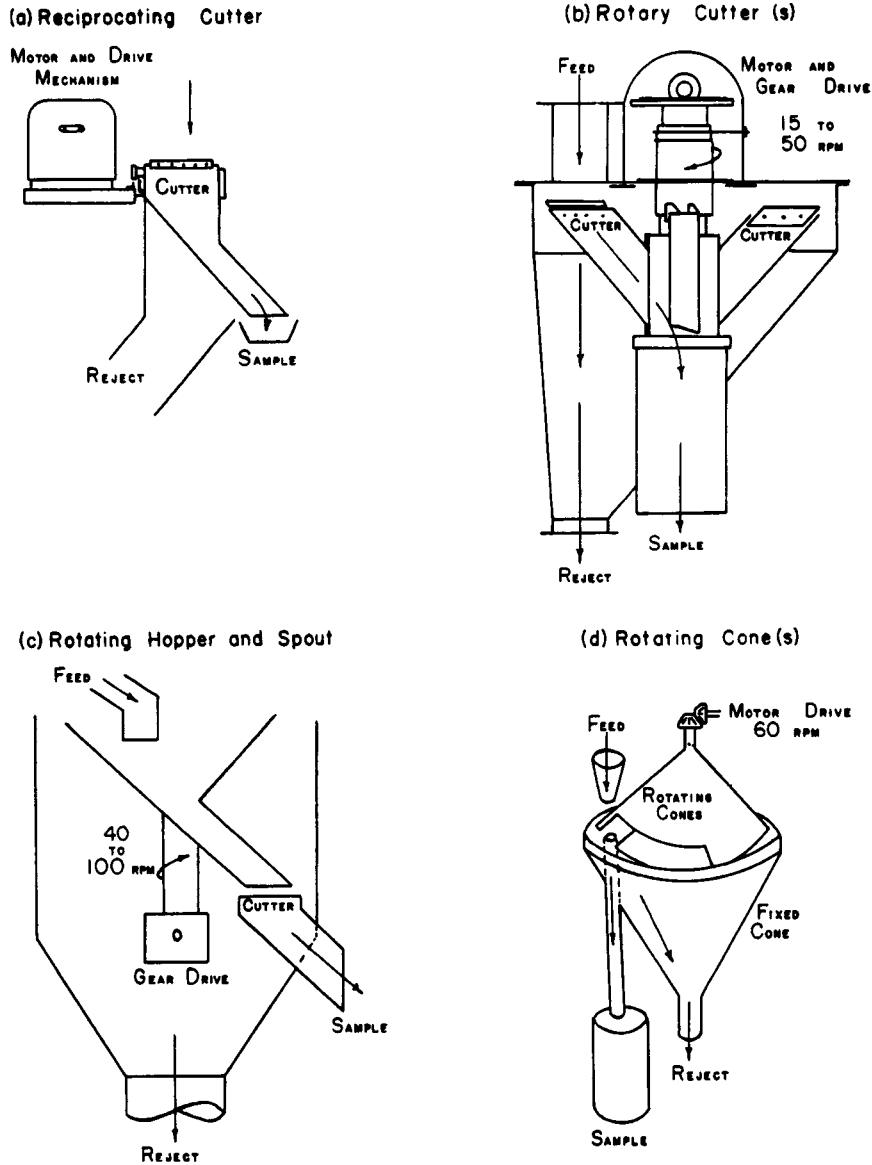

(a) *Reciprocating Cutter*—Fig. 1(a) shows a section of a cutter which is moved across a stream of coal. At regular intervals, the cutter movement is reversed and a sample increment is collected on each trip through the coal stream.

(b) *Rotating Cutter*—Fig. 1(b) shows two cutters attached to a hollow, rotating shaft. Each cutter is designed to extract increments from the feed and to discharge these into the hollow shaft. One or more cutters may be used.

(c) *Rotating Hopper and Spout*—Fig. 1(c) shows the totaling hopper that receives the crushed sample and discharges it through a spout over one or more stationary cutters.

(d) *Rotating Cone*—A sampler developed by the British National Coal Board. Two slotted cones are locked together and rotated on a vertical shaft so that on each revolution the common slot operating intercepts the falling stream of coal and collects an increment.

FIG. 1 Mechanical Sample Dividers

the course of preparation of an air-dried subsample, the subsample shall be weighed and its moisture equilibrated with the new atmosphere, and the loss or gain in mass shall be used in the calculation of moisture content.

8. Sieve Tests

8.1 The errors of sample division are sensitive to the top size, and therefore, it is important to make a periodic sieve test of the product of the sample crusher. Sieve tests shall be made and reported in accordance with Test Method D 4749, except when more than 50 % passes the No. 8 (2.36-mm) sieve. Sieve tests on the portions passing the No. 8 sieve shall be made in accordance with Test Method D 197.

9. Procedure

9.1 *Mass*—The minimum allowable mass of the sample at any stage depends on the top size, the variability of the constituent sought, and the degree of precision desired (Table 1).

9.2 *Reduction and Division* (See Fig. 3 for flowchart):

9.2.1 It is permissible to air dry the sample before crushing. Samples may require air drying to feed properly through the reduction and dividing equipment. Sometimes there is an interest in determining the air-dry loss value before crushing. Air dry in accordance with Test Method D 3302.

9.2.2 In the reduction and division of gross or divided

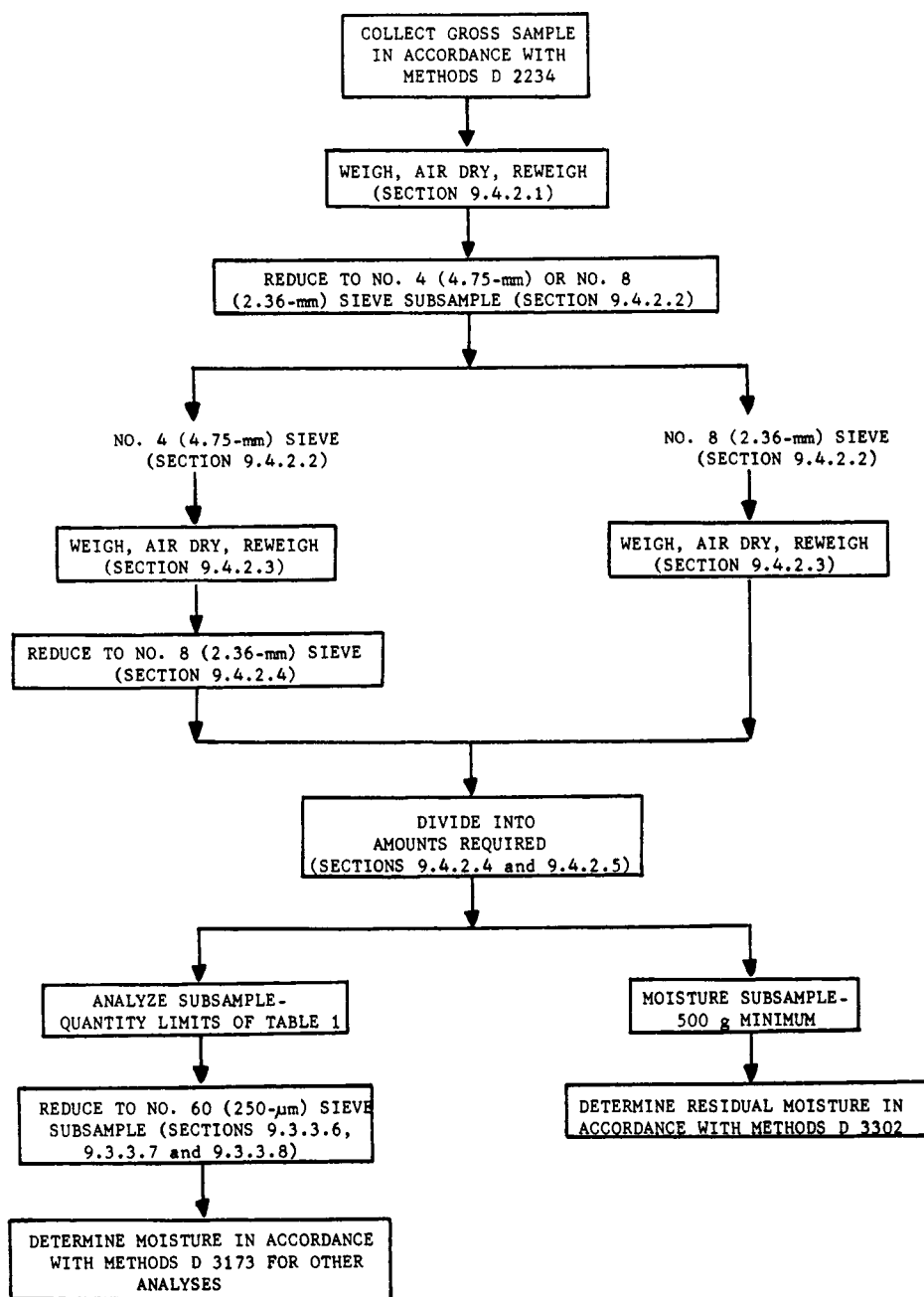

FIG. 2 Gross Sample Preparation for Moisture Determination (Referee Method)

samples for which total moisture content is to be determined, the precautions in 7.3 and 7.4 must be followed.

9.2.3 Procedure A—Manual Riffing:

9.2.3.1 Reduce the gross or divided sample to a top size of 4.75-mm (No. 4) or 2.36-mm (No. 8) sieve taking precautions in accordance with Section 7.

9.2.3.2 Determine the number of passes required in the riffing operation from the total mass of the gross sample and the minimum permissible mass in accordance with Table 1.

9.2.3.3 Divide the crushed sample by using a large riffle. Riffles properly used will reduce sample variability but cannot eliminate it. A typical enclosed riffle is shown in Fig. 3 and described in 6.2.2. Pass the coal through the riffle from a feed scoop, feed bucket, or riffle pan having a lip or opening the full

width of the riffle. When using any of the preceding containers to feed the riffle, spread the coal evenly in the container, raise the container, and hold it with its front edge resting on top of the feed chute, then slowly tilt it so that the coal flows in a uniform stream through the hopper straight down over the center of the riffle into all the slots, then into the riffle pans, one half of the sample being collected in each pan. Under no circumstances shovel the sample into the riffle or dribble into the riffle from a small-mouthed container. Do not allow the coal to build up in or above the riffle slots. If it does not flow freely through the slots, shake or vibrate the riffle to facilitate even flow.

9.2.3.4 If the initial crushing was only to 4.75-mm (No. 4) sieve size, reduce to 2.36-mm (No. 8) sieve size after dividing

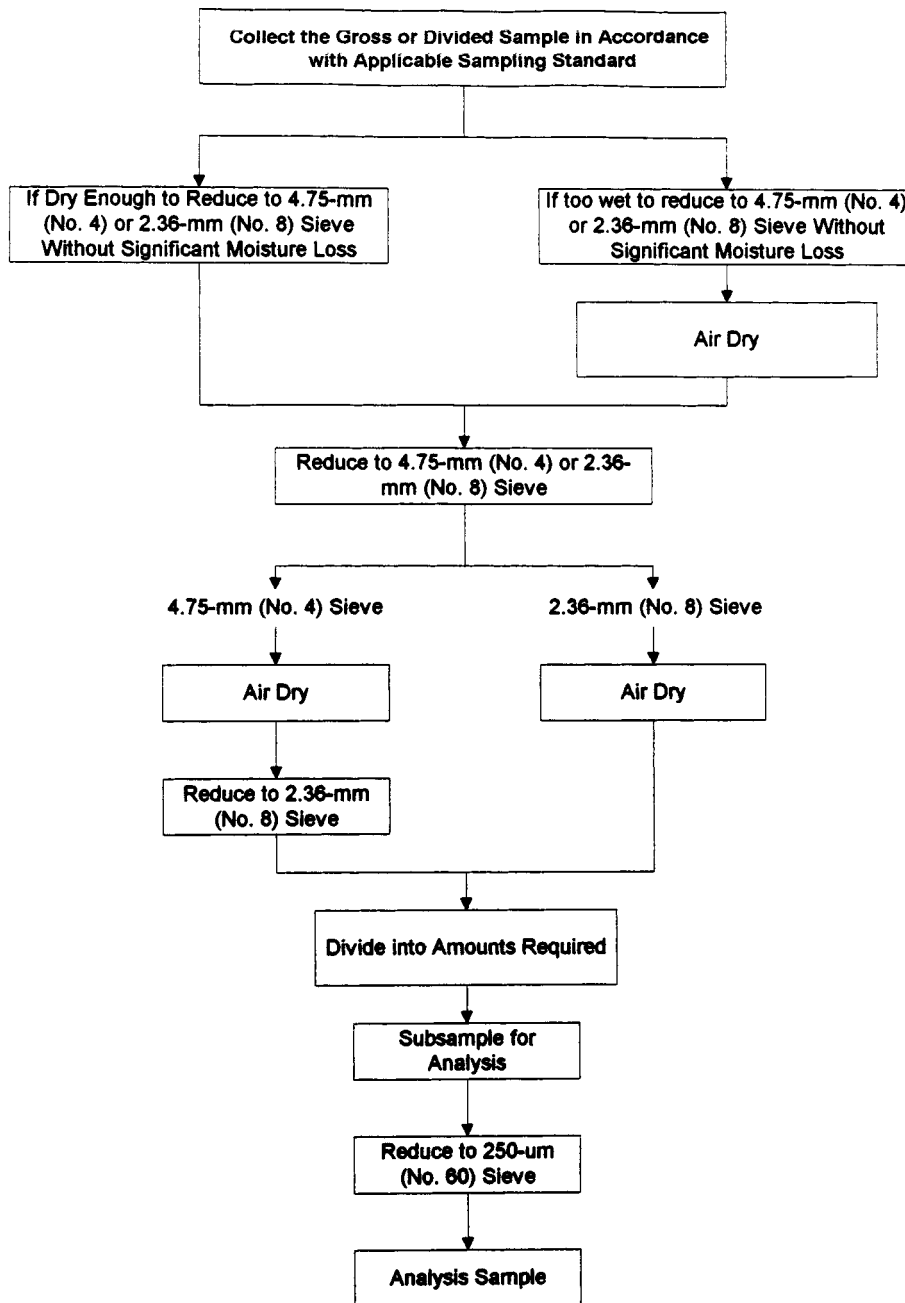

FIG. 3 Gross Sample Preparation Flowchart

to no less than the quantity specified in Table 1 for a 4.75-mm (No. 4) sieve size.

9.2.3.5 After reducing to 2.36-mm (No. 8) sieve size, divide the subsample by riffing to no less than the quantity specified in Table 1 for a 2.36-mm sieve size.

9.2.3.6 With suitable pulverizing equipment (see 6.1), reduce the 2.36-mm (No. 8) sieve size subsample to a 250- $\mu$ m (No. 60) sieve size. Divide the ground subsample by riffing, using the small riffle (see 6.2.2) until a minimum of 50 g is obtained. Quickly pass the subsample through a 250- $\mu$ m (No. 60) sieve. Reduce the particles retained on the screen, on a bucking board or mortar and pestle to pass the sieve, and add to what passed through the sieve and mix thoroughly. This is the analysis sample.

9.2.3.7 As an alternative to the procedure of 9.2.3.6, the 2.36-mm (No. 8) sieve size subsample may be reduced to pass 95 % through a 850- $\mu$ m (No. 20) sieve. Divide this subsample by riffing with the small riffle to not less than the quantity specified in Table 1, and then reduce to 250- $\mu$ m (No. 60) sieve size in accordance with 9.2.3.6.

9.2.3.8 Thoroughly mix, preferably by mechanical means, the analysis sample, weighing not less than 50 g, before extracting portions for analysis (see 6.3).

9.2.4 Procedure B—Mechanical Division:

9.2.4.1 Reduce the gross or divided sample in stages and divide by suitable mechanical sample dividers (see 6.2.1) to quantities not less than those shown in Table 1.

9.2.4.2 Mechanical division of the sample consists of automatically collecting a large number of increments of the properly reduced sample. Distribute this large number of increments equally throughout the entire discharge from the sample crusher because crushers can introduce appreciable segregation. At each stage of division, take at least 60 increments.

NOTE 1—It is recommended that, in the case of mechanical division in which an increment is not thoroughly mixed with other increments before division, a portion of each increment be collected by the subsequent stage increment collection process.

9.2.4.3 Thoroughly mix the analysis sample, 100 % through

250- $\mu\text{m}$  (No. 60) sieve and weighing not less than 50 g, in accordance with 9.2.3.8 before extracting portions for analysis.

## 10. Precision and Bias

10.1 The precision of sample preparation (and analysis) can be checked by Annex A1 and Annex A2. Since this practice does not produce a numerical result, determination of bias is not applicable.

## 11. Keywords

11.1 coal; division; reduction

## ANNEXES

### (Mandatory Information)

#### A1. METHOD OF CHECKING THE PRECISION OF SAMPLE PREPARATION AND ANALYSIS

##### A1.1 Scope

A1.1.1 This method covers procedures for checking precision of sample preparation and analysis of the various stages. The data obtained from tests using consistent sample preparation and analysis method are used to estimate the random errors in the various stages of sample division and analysis.

A1.1.2 Coals used in each series of tests should be of similar ash content.

##### A1.2 Procedure

A1.2.1 Reduce the gross sample to 95 % through No. 4 (4.75-mm) sieve and divide, using either riffles or mechanical sample dividers, into two equal parts.

A1.2.1.1 Many laboratories are crushing directly to No. 8 (2.36-mm) size instead of to No. 4; but for purpose of test it is usually best to use both No. 4 and 8 sizes since we can assume that crushing directly to No. 8 would give a variance no greater, and probably less, than crushing to No. 4 and then to No. 8. If, however, it is desired to crush directly to No. 8, follow the same procedure as if crushed to No. 4 and then to No. 8.

A1.2.2 Divide each subsample by riffing or mechanically to no less than weights as outlined in Table 1.

A1.2.2.1 Individual weights should not vary more than  $\pm 20\%$  from the weights given in Table 1, and the average of all tests should be within  $\pm 10\%$  of the weights.

A1.2.3 Reduce the No. 4 (4.75-mm) sieve laboratory sample 95 % through No. 8 (2.36-mm) sieve and divide, using either riffles or mechanical sample dividers, into two equal parts without discarding. Divide each subsample to no less than the minimum weights as outlined in Table 1.

A1.2.4 Reduce each part of the No. 8 subsample to 100 % through No. 60 (250- $\mu\text{m}$ ) sieve and divide to no less than 50 g.

A1.2.5 Determine ash in accordance with Test Method D 3174 in duplicate on each analysis sample.

A1.2.5.1 This test can be used for sulfur, Btu, or other determinations, instead of ash, if desired.

A1.2.5.2 If possible, the duplicate determinations should be

made at different times and preferably by different analysts. The purpose of these tests is not to find out how accurate a laboratory can be, but to find out actual variances of preparation and analysis in the normal routine of a laboratory following a prescribed procedure.

A1.2.6 Treat three sets of ten samples each in the preceding manner.

A1.2.6.1 Make calculations on the first set of ten samples so that the variance for each of the stages may be checked and corrective action, if needed, may be taken.

A1.2.6.2 Continue this cycle of tests until three successive sets of ten samples are satisfactory.

##### A1.3 Calculation

A1.3.1 The analysis of variance is based upon the calculations of mean squared differences with the eight determinations for each sample taken in different combinations. Calculate the variances of these combinations:  $VP$ , the variance of the difference between duplicate analyses;  $VQ$ , the variance of the difference between the averages of duplicate analyses; and  $VR$ , the variance of the difference between the average of each four analyses, as follows:

$$VP = (1/4N) \Sigma [X1 - X2)^2 + (X3 - X4)^2 + (Y1 - Y2)^2 + (Y3 - Y4)^2] \quad (\text{A1.1})$$

where:

$N$  = number of tests and  
 $X1, X2, X3, X4, Y1, Y2, Y3, Y4$  = individual ash determinations.

$$VQ = \left(\frac{1}{2N}\right) \Sigma \left[ \left( \frac{X1 + X2}{2} - \frac{X3 + X4}{2} \right)^2 + \left( \frac{Y1 + Y2}{2} - \frac{Y3 + Y4}{2} \right)^2 \right] \quad (\text{A1.2})$$

$$VR = (1/N) \Sigma \left[ \left( \frac{X1 + X2 + X3 + X4}{4} - \frac{Y1 + Y2 + Y3 + Y4}{4} \right)^2 \right] \quad (\text{A1.3})$$

A1.3.2 The variances can be resolved further in terms of variance caused by the first stage of sample preparation,  $V1$ ;

variance caused by the second stage of sample preparation,  $V2$ ; and the variance of analysis,  $Va$ .

where:

$$Va = \frac{1}{2} VP,$$

$$V2 = \frac{1}{2} VQ - \frac{1}{4} VP, \text{ and}$$

$$V1 = \frac{1}{2} VR - \frac{1}{4} VQ.$$

A1.3.3 The total variance of sample preparation and analysis,  $S_{da}^2$ , is given by the equation:

$$S_{da}^2 = Va + V2 + V1 \quad (A1.4)$$

A1.3.4 The calculations of the variances of sample preparation are illustrated in Table A1.1.



**TABLE A1.1 Illustrations of the Calculation of the Variances<sup>A</sup> of Sample Preparation at the Various Stages and Analysis**

Test No.	X1	X2	Difference	Difference <sup>2</sup>	X3	X4	Difference	Difference <sup>2</sup>
1	12.13	12.10	0.03	0.0009	12.03	12.05	-0.02	0.0004
2	10.67	10.73	-0.06	0.0036	10.69	10.78	-0.09	0.0081
3	10.93	11.10	-0.17	0.0289	11.36	11.45	-0.09	0.0081
4	12.05	12.02	0.03	0.0009	12.17	12.23	-0.06	0.0036
5	12.74	12.70	0.04	0.0016	12.71	12.76	-0.05	0.0025
6	12.47	12.30	0.17	0.0289	12.21	12.14	0.07	0.0049
7	11.94	11.99	-0.05	0.0025	12.08	12.17	-0.09	0.0081
8	12.52	12.63	-0.11	0.0121	12.76	12.82	-0.06	0.0036
9	12.01	12.05	-0.04	0.0016	11.94	11.77	0.17	0.0289
10	10.96	10.88	0.08	0.0064	11.37	11.40	-0.03	0.0009
Total	118.42	118.50		0.0874	119.32	119.57		0.0691
Average	11.84	11.85			11.93	11.96		

Test No.	Y1	Y2	Difference	Difference <sup>2</sup>	Y3	Y4	Difference	Difference <sup>2</sup>
1	12.00	12.01	-0.01	0.0001	12.00	12.00	0.00	0.0000
2	10.53	10.65	-0.12	0.0144	10.60	10.62	-0.02	0.0004
3	11.37	11.47	-0.10	0.0100	11.22	11.35	-0.13	0.0169
4	12.13	12.10	0.03	0.0009	12.01	12.04	-0.03	0.0009
5	12.60	12.60	0.00	0.0000	12.51	12.40	0.11	0.0121
6	12.09	12.15	-0.06	0.0036	12.18	12.20	-0.02	0.0004
7	11.93	11.87	0.06	0.0036	11.71	11.73	-0.02	0.0004
8	12.57	12.57	0.00	0.0000	12.58	12.61	-0.03	0.0009
9	11.81	11.88	-0.07	0.0049	11.70	11.84	-0.14	0.0196
10	11.57	11.48	0.09	0.0081	11.54	11.36	0.18	0.0324
Total	118.60	118.78		0.0456	118.05	118.15		0.0840
Average	11.86	11.88			11.81	11.82		

Test No.	X(1 + 2)/2	X(3 + 4)/2	Difference	Difference <sup>2</sup>	Y(1 + 2)/2	Y(3 + 4)/2	Difference	Difference <sup>2</sup>
1	12.11	12.04	0.07	0.0056	12.00	12.00	0.00	0.0000
2	10.70	10.73	-0.03	0.0012	10.59	10.61	-0.02	0.0004
3	11.01	11.40	-0.39	0.1521	11.42	11.28	0.13	0.0182
4	12.03	12.20	-0.16	0.0272	12.11	12.02	0.09	0.0081
5	12.72	12.73	-0.01	0.0002	12.60	12.45	0.14	0.0210
6	12.38	12.17	0.21	0.0441	12.12	12.19	-0.07	0.0049
7	11.96	12.12	-0.16	0.0256	11.90	11.72	0.18	0.0324
8	12.57	12.79	-0.21	0.0462	12.57	12.59	-0.02	0.0006
9	12.03	11.85	0.17	0.0306	11.84	11.77	0.07	0.0056
10	10.92	11.38	-0.46	0.2162	11.52	11.45	0.07	0.0056
Total	118.46	119.44		0.5491	118.69	118.10		0.0969
Average	11.85	11.94			11.87	11.81		

Test No.	X(1 + 2 + 3 + 4)/4	Y(1 + 2 + 3 + 4)/4	Difference	Difference <sup>2</sup>
1	12.07	12.00	0.07	0.0056
2	10.71	10.60	0.11	0.0138
3	11.21	11.35	-0.04	0.0203
4	12.11	12.07	0.04	0.0022
5	12.72	12.52	0.20	0.0400
6	12.28	12.15	0.12	0.0156
7	12.04	11.81	0.23	0.0552
8	12.68	12.58	0.10	0.0100
9	11.94	11.80	0.13	0.0182
10	11.15	11.48	-0.33	0.1122
Total	118.95	118.39		0.2932
Average	11.90	11.84		

$$VP = \frac{1}{40} (0.0874 + 0.0691 + 0.0456 + 0.0840) = 0.0071$$

$$VQ = \frac{1}{20} (0.5491 + 0.0969) = 0.0323$$

$$VR = \frac{1}{10} (0.2932) = 0.0293$$

Then:

$$Va = \frac{1}{2} (0.0071) = 0.0035$$

$$V_2 = \frac{1}{2} (0.0323) - \frac{1}{4} (0.0071) = 0.0144$$

$$V_1 = \frac{1}{2} (0.0293) - \frac{1}{4} (0.0323) = 0.0066$$

$$S_{da}^2 = 0.0035 + 0.0144 + 0.0066 = 0.0245$$

<sup>A</sup>This table contains data taken from a computer printout with rounding errors that are not involved in the overall calculation. Data taken at intermediate steps are not consistent within limits of these rounding errors. Thus, the difference 0.07<sup>2</sup> shows a result of 0.0056 which is correct when all places are carried in the calculation.



## A2. METHOD FOR DETERMINING THE OVERALL VARIANCE OF DIVISION AND ANALYSIS<sup>4</sup>

### A2.1 Scope

A2.1.1 Legitimate estimates of the variance of division and analysis,  $S_{da}^2$ , can only be made using data obtained from tests that were run using consistent division and analysis methods. Coals used in these variance tests should be of similar ash content. Any gross change in the division and analysis methods or in the ash characteristics of the test coal will nullify the test results.

### A2.2 Procedure

A2.2.1 The following four-step method uses the regular gross or divided samples obtained from normal sampling operations:

A2.2.1.1 Crush the gross sample to the same mesh as that normally obtained when preparing the gross sample for processing,

A2.2.1.2 Divide the sample into four equal parts, according to the normal routine laboratory procedure,

A2.2.1.3 Reduce the four subsamples to laboratory analysis samples, and

A2.2.1.4 Analyze each analysis sample for dry ash content.

A2.2.2 Calculate the variance of division and analysis for each gross or divided sample from the “within set sums of squares” for the replicate determinations as follows:

$$S_{da}^2 = [\sum x^2 - (\sum x)^2/4]/3 \quad (A2.1)$$

where:

$S_{da}^2$  = variance of division and analysis,

$x^2$  = sum of the squares of the four ash results, and

$(\sum x)^2$  = sum of the ash results, quantity squared.

A2.2.3 Make progressive checks as the work is carried out by using the data in groups of 5. In any group of 5 estimates of  $S_{da}^2$  based on 4 subsamples for each estimate, the ratio of the largest estimate to the average of the group should not exceed 2.99, in 19 out of 20 cases. Investigate values in excess of this ratio before proceeding with the test. In addition, after completing 30 sets, by groups of 5, the ratio of the largest group average to the overall average should not exceed 1.88 in 19 cases out of 20. If these criteria are met, the variance of division and analysis may be taken as the overall average  $S_{da}^2$  of the 30 sets of data. If these criteria are not met, follow the procedure described in Practice D 2013 for the necessary information to improve techniques of division and analysis.

A2.2.4 *Example*—A complete example illustrating the procedure for determining the variance of division and analysis is given in Table A2.1. In this example, gross sample No. 24, the highest individual ash sample in the group (19.28 % ash), has an unusually high variance of division and analysis. The behavior of samples 21 to 30 indicates that trouble can be expected when the ash exceeds 15 % (see Table A2.1).

**TABLE A2.1 Determination of Variance of Division and Analysis—Use of Four Analysis Samples for Each Gross Sample**

NOTE 1—Ten percent ash was subtracted from each of the ash results listed to simplify the calculations.

Gross Sample Number	Analysis Samples				$\Sigma x$	$\Sigma x^2$	$(\Sigma x)^2/4$	(6)–(7)	(8)/3 = $S_{da}^2$	Average Sets of 5 $S_{da}^2$	$C_i^A$	$C_i^B$
	(1)	(2)	(3)	(4)								
1	1.22	1.37	1.56	1.71	5.86	8.7230	8.5849	0.1381	0.0460		1.62	
2	1.29	1.17	1.70	1.57	5.73	8.3879	8.2082	0.1797	0.0599		2.11	
3	1.56	1.66	1.58	1.64	6.44	10.3752	10.3684	0.0068	0.0023		0.08	
4	5.63	5.57	5.93	5.52	22.65	128.3571	128.2556	0.0015	0.0005		0.02	
5	3.90	3.87	3.58	3.56	14.91	55.6769	55.5770	0.0999	0.0333		1.17	
Average	...	...	...	...	12.78	...	...	...	...	0.0284	...	0.61
6	0.64	0.42	0.80	0.73	2.59	1.7589	1.6770	0.0819	0.0273		1.12	
7	2.47	2.44	2.74	2.68	10.33	26.7445	26.6772	0.0673	0.0227		0.93	
8	3.70	3.53	3.43	3.43	14.09	49.6807	49.6320	0.0487	0.0162		0.66	
9	3.59	3.73	4.13	3.80	15.25	58.2979	58.1406	0.1573	0.0524		2.15	
10	2.14	2.17	2.25	2.11	8.67	18.8031	18.7922	0.0109	0.0036		0.15	
Average	...	...	...	...	12.55	...	...	...	...	0.0244	...	0.52
11	5.71	5.61	5.61	5.71	22.64	128.1524	128.1424	0.0100	0.0033		0.09	
12	3.21	3.40	2.86	2.90	12.37	38.4537	38.2542	0.1995	0.0665		1.87	
13	4.99	4.80	5.51	4.93	20.23	102.6051	102.3132	0.2919	0.0973		2.74	
14	3.26	3.15	3.17	3.09	12.67	40.1471	40.1322	0.0149	0.0050		0.14	
15	3.48	3.65	3.59	3.53	14.25	50.7819	50.7656	0.0163	0.0054		0.15	
Average	...	...	...	...	14.11	...	...	...	...	0.0355	...	0.76
16	2.89	2.84	2.85	2.89	11.47	32.8923	32.8902	0.0021	0.0007		0.02	
17	2.35	2.48	2.90	2.71	10.44	27.4270	27.2484	0.1786	0.0595		1.86	
18	4.23	3.92	4.13	4.05	16.33	66.7187	66.6672	0.0515	0.0172		0.54	
19	5.46	5.13	5.13	5.38	21.10	111.3898	111.3025	0.0873	0.0291		0.91	
20	3.15	2.98	3.42	3.47	13.02	42.5402	42.3801	0.1601	0.0534		1.67	
Average	...	...	...	...	13.62	...	...	...	...	0.0320	...	0.69
21	2.88	2.81	2.80	2.59	11.08	30.7386	30.6916	0.0470	0.0157		0.17	
22	4.94	4.32	4.40	4.39	18.05	81.6981	81.4506	0.2945	0.0982		1.05	
23	4.04	4.28	4.47	4.48	17.27	74.6913	74.5632	0.1281	0.0427		0.46	
24	8.38	8.28	8.93	9.28	34.87	304.6461	303.9792	0.6669	0.2223		2.39	
25	6.93	6.97	6.37	6.54	26.81	179.9543	179.6940	0.2603	0.0868		0.93	
Average	...	...	...	...	15.40	...	...	...	...	0.0931	...	2.00 <sup>C</sup>
26	4.52	4.27	3.66	4.07	16.52	68.6238	68.2276	0.3962	0.1321		2.02	
27	4.53	4.46	4.54	4.65	18.18	82.6466	82.6281	0.0185	0.0062		0.09	
28	2.18	2.42	2.45	2.31	9.36	21.9474	21.9024	0.0450	0.0150		0.23	
29	8.84	9.21	8.69	8.55	35.29	311.5883	311.3460	0.2423	0.0808		1.24	
30	5.03	4.73	5.47	5.11	20.34	103.7068	103.4289	0.2779	0.0926		1.42	
Average	...	...	...	...	14.98	...	...	...	...	0.0653	...	1.40
Overall average	...	...	...	...	...	...	...	...	...	0.0465	...	...
$S_{da}^2$												

<sup>A</sup>“C” for individuals in subgroup. Divide individual  $S_{da}^2$  values (Column 9) by average  $S_{da}^2$  (Column 10). Results should be below 2.99 in 19 cases out of 20.

<sup>B</sup>“C” for subgroup averages. Divide average  $S_{da}^2$  (Column 10) by overall averages  $S_{da}^2$ . Result should be below 1.88 in 19 cases out of 20.

<sup>C</sup>Above limit of 1.88.

The American Society for Testing and Materials takes no position respecting the validity of any patent rights asserted in connection with any item mentioned in this standard. Users of this standard are expressly advised that determination of the validity of any such patent rights, and the risk of infringement of such rights, are entirely their own responsibility.

This standard is subject to revision at any time by the responsible technical committee and must be reviewed every five years and if not revised, either reapproved or withdrawn. Your comments are invited either for revision of this standard or for additional standards and should be addressed to ASTM Headquarters. Your comments will receive careful consideration at a meeting of the responsible technical committee, which you may attend. If you feel that your comments have not received a fair hearing you should make your views known to the ASTM Committee on Standards, at the address shown below.

This standard is copyrighted by ASTM, 100 Barr Harbor Drive, PO Box C700, West Conshohocken, PA 19428-2959, United States. Individual reprints (single or multiple copies) of this standard may be obtained by contacting ASTM at the above address or at 610-832-9585 (phone), 610-832-9555 (fax), or service@astm.org (e-mail); or through the ASTM website (www.astm.org).