



Designation: D 2014 – 97

Standard Test Method for Expansion or Contraction of Coal by the Sole-Heated Oven¹

This standard is issued under the fixed designation D 2014; the number immediately following the designation indicates the year of original adoption or, in the case of revision, the year of last revision. A number in parentheses indicates the year of last reapproval. A superscript epsilon (ϵ) indicates an editorial change since the last revision or reapproval.

1. Scope

1.1 This test method covers a large-scale laboratory test for obtaining information on the expansion or contraction of coal or coal blends during carbonization under specified conditions. This test method is applicable in the examination of coals or coal blends intended for use in the manufacture of coke.

1.2 The values stated in SI units shall be regarded as standard. Inch-pound units shall be accepted on an equivalent basis.

1.3 *This standard does not purport to address all of the safety concerns, if any, associated with its use. It is the responsibility of the user of this standard to establish appropriate safety and health practices and determine the applicability of regulatory limitations prior to use.*

2. Referenced Documents

2.1 ASTM Standards:

- D 2013 Method of Preparing Coal Samples for Analysis²
- D 2234 Practice for Collection of a Gross Sample of Coal²
- D 3302 Test Method for Total Moisture in Coal²
- E 11 Specification for Wire-Cloth Sieves for Testing Purposes³

3. Summary of Test Method

3.1 During the test, a measured thickness of coal about 102 mm (4 in.) is heated from the bottom surface while a force corresponding to 15.2 kPa (2.20 psi) is applied to the top surface through a piston. At the end of the test, the thickness of the coke is measured by observing the final position of the piston.

4. Significance and Use

4.1 The values determined in this test method indicate to what extent a given coal or coal blend will expand or contract during the carbonization process when evaluated in terms of

pertinent experience with other coals and coal blends and processing conditions used in commercial-type coke ovens.

5. Apparatus

5.1 *Test Oven Assembly*, consisting of the following: either a single-chamber oven having approximately 280-mm (11-in.) width, 610-mm (24-in.) length, and 280-mm depth, or a double-chambered oven with two chambers each having approximately 280-mm width, length, and depth; a heating system to heat the charge(s) unidirectionally through the sole according to a controlled program; piston(s) arranged so that a constant load may be applied to the top surface of the charge; and suitable instrumentation so that appropriate temperatures and the position of the piston(s) may be measured. The auxiliary equipment includes apparatus facilitating the charging of the oven in a standard manner. The vertical partition of the double-chambered oven may be of 2-in. (51-mm) firebrick tile or equivalent.

5.1.1 Carbonization Chamber:

5.1.1.1 The sole shall be of silicon carbide tile, about 40 mm (1.5 in.) thick, 305 mm (12 in.) wide, and extending approximately 75 mm (3 in.) beyond the carbonization chamber at the front and back. Side, front, and back walls should be 40-mm firebrick tile or equivalent. It is appropriate to key the sole to the side and back tiles. The top edges of sidewalls shall be held in an adjustable steel framework so that the walls may be made and maintained precisely perpendicular to the sole. Hole(s) 6.35 mm (0.25 in.) in diameter shall be provided through the side of the oven to enable the placement of thermocouple(s) on the top surface of the sole in the center of the oven chamber(s).

5.1.1.2 In constructing the oven, the sides and ends of the carbonization chamber shall be surrounded with at least 200 mm (8 in.) of insulating refractories and the whole assembly encased in a suitable restraining structure of steel shapes and plates designed to provide dimensional stability.

5.1.2 Sole-Heating System:

5.1.2.1 The heating system shall consist of a group of electrical heating elements mounted under the silicon carbide sole and suitable equipment to provide automatic control. Heating elements may be either silicon carbide-type resistance elements or coils of heating wire enclosed in silica tubes. Elements shall be arranged to obtain minimum variation of temperature over the area of the sole. It is desirable to

¹ This test method is under the jurisdiction of ASTM Committee D-5 on Coal and Coke and is the direct responsibility of Subcommittee D05.15 on Metallurgical Properties of Coal and Coke.

Current edition approved April 10, 1997. Published May 1998. Originally published as D2014 – 62. Last previous edition D2014 – 96a.

² *Annual Book of ASTM Standards*, Vol 05.05.

³ *Annual Book of ASTM Standards*, Vol 14.02.

incorporate a maximum number of supports for the silicon carbide sole tile. The brickwork and steelwork beneath the heating flues shall be of appropriate design to maintain rigidity of the oven under the temperature and load stresses of operation.

5.1.2.2 The thermocouple used for temperature control is located in a position which enables the sole to be heated in accordance with the sole temperature program shown in Table 1. The heating system shall be capable of reaching the initial set point temperature of 554°C within 10 min of charging the oven and of heating the sole in accordance with the sole temperature program shown in Table 1.

5.1.2.3 The temperature control thermocouple may be installed in the heating flue or in contact with the sole plate.

5.1.3 *Piston*—The piston assembly shall include a massive bottom plate of metal to which an upper steel assembly is rigidly attached. The bottom plate shall be 19- or 25-mm (0.75- or 1-in.) cast steel or cast iron in one piece with square edges. Dimensions are to be so chosen that the clearances between piston edges and chamber walls, ends, and sides, at the conclusion of a test (upper surface of coal at 500°C) are at least 3.2 mm (0.125 in.) but not as much as 9.5 mm (0.375 in.). A 10- to 130-mm (4.5- to 5-in.) layer of insulating refractory shall be formed upon the steel plate, the sides being recessed somewhat within the piston edges. The upper steel assembly shall be rigidly fastened to the corners of the lower plate with steel supports. The upper steel assembly and corner supports shall be of adequate strength to permit application of the desired load and shall be fitted with appropriate hardware to permit ready placement into or removal from the carbonization chamber. A vertical hole, 13 mm (0.5 in.) in diameter, piercing the piston assembly, including lower plate shall be provided on the longitudinal center line for a thermocouple, about 200 mm (8 in.) from either the front or rear edge of the piston.

5.1.4 *Apparatus for Loading Piston*—Apparatus shall be provided so that a constant load of 15.17 ± 0.35 kPa (2.20 ± 0.05 psi) calculated over the measured area of the piston plate, may be applied to the piston during the test. The manner of applying this load is not critical. Examples of suitable procedures are (1) use of a hydraulic piston as shown in Fig. 1, (2) use of a hinged lever-arm system bearing on a fulcrum mounted on the upper steelwork of the piston structure, and (3) placement of sufficient additional dead weights on the piston itself. Whatever system is chosen should be characterized by rapid assembly for the prompt application of force after charging.

TABLE 1 Sole Temperatures Program

Time, (h) After Initial Setpoint of 554°C Achieved	Temperature, °C
0.00	554
1.00	685
2.00	777
3.00	840
4.00	889
5.00	921
6.00	943
7.00	950
from then on	950

6. Instrumentation

6.1 *Piston Movement*—The excursion of the piston from an initial reference position may be measured either manually, by observing the movement of an indicator, or automatically by means of an appropriate transducer and recording system. A preferred form of indicator is a witness point on a silica rod mounted on the upper surface of the lower piston plate and not connected in any way to the remaining piston structure. When using this design of indicator, no corrections need be made for expansion of the piston structure itself. Alternatively, the basic indicator may be mounted on the upper steel structure of the piston. In this event, any correction for piston expansion during a test, if necessary, shall be determined by appropriate preliminary calibration. Measurements of the position of the indicator may be made by directly observing the witness point with a cathetometer or by using a suitable mechanical or electrical system of magnifying movement. Apparatus of the latter type should be calibrated with an accurate cathetometer. Whatever type of indicator is used it shall be placed as close to the geometric center of the piston as possible.

6.1.1 Thermocouples shall be provided for measuring both the temperature of the top surface of the sole (maximum of about 950°C) and the temperature of the top surface of the coal (maximum about 500°C) (Note 2). The thermowell containing the sole couple shall be placed horizontally through the hole in the sidewall or endwall tile so that the thermowell lies flat with its tip near the geometric center of the sole. The thermowell containing the top surface thermocouple shall be placed in the vertical hole in the piston and adjusted so that its lowest point is flush with the lower surface of the piston plate.

NOTE 1—Type K Chromel-Alumel thermocouples have proven satisfactory in these applications. Quartz or porcelain is a satisfactory material for thermocouple protection tubing. Mild steel or stainless tubing may also be used but will require frequent replacement.

7. Accessory Equipment

7.1 *Auxiliary Apparatus*—Necessary auxiliary apparatus includes a sole cover plate, a charging hopper, and an adjustable leveling device:

7.1.1 *Sole Cover Plate*, conforming to the dimensions of the piston plate and consisting of a suitable metal framework containing either a layer of insulating brick or an equivalent layer of insulating refractory. It shall be placed on the sole overnight and during other short periods of nonoperation to reduce heat losses and facilitate maintenance of proper sole temperature before the start of a test.

7.1.2 *Hopper and Leveling Device*—Functionally adequate designs of hopper and leveling devices are shown in Fig. 2. The leveling device should be constructed so as to be quickly adjustable.

7.1.3 The provision of a permanently installed crane for handling the piston in and out of the carbonization chamber facilitates convenience of operation. A hood over the whole assembly is desirable for the removal and venting of carbonization gases.

8. Sampling

8.1 The gross sample shall be collected in accordance with Practice D 2234.

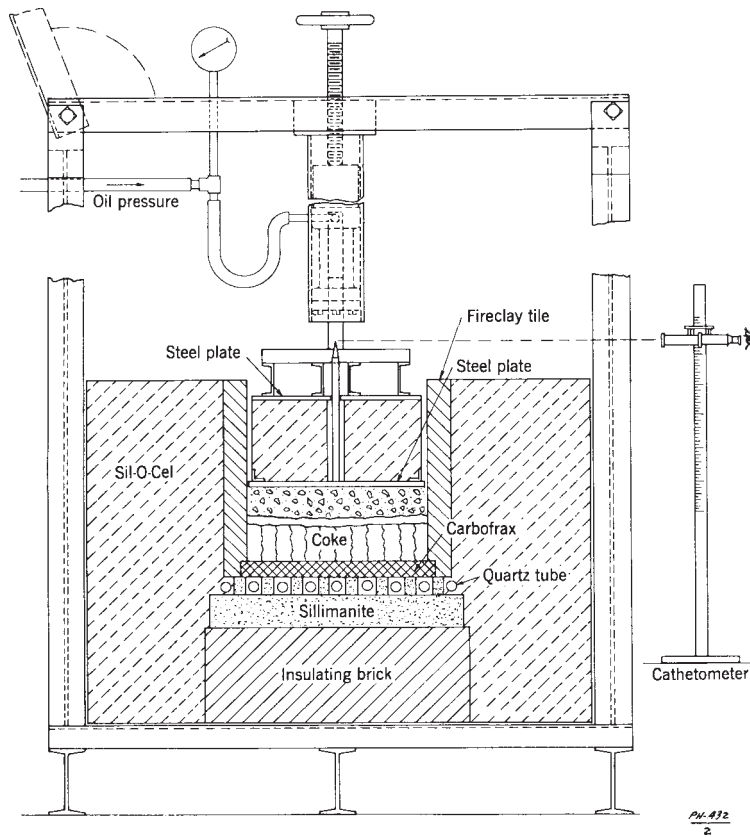
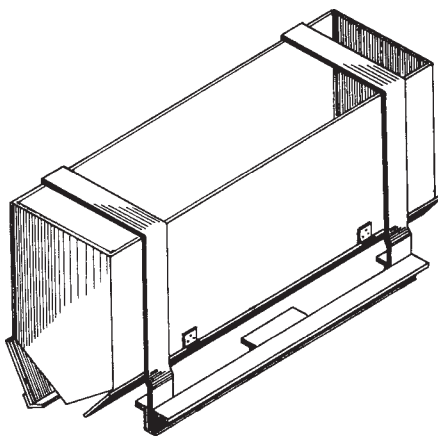
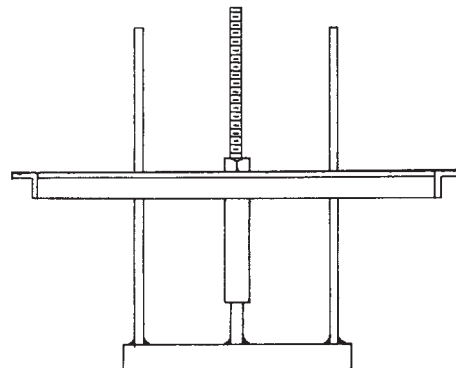

FIG. 1 Sole-Heated Oven



(a) Oven Charging Device.



(b) Coal Leveling Device.

FIG. 2 Auxiliary Equipment

8.2 About 30 kg (66 lbs) of sample (sufficient for performing duplicate sole-heated oven tests) shall be prepared. The sample shall pass a 4.75-mm (No. 4) sieve and shall have between 2 and 4 % total moisture content. Only oversized coal is to be stage crushed to prepare the sample to pass a 4.75-mm (No. 4) sieve. If required, moisture content may be reduced by air drying. Heating the air is permitted provided that the heated air is $\leq 10^{\circ}\text{C}$ above ambient conditions and never exceeds 35°C . The prepared sample is to be placed in a sealed container

until ready for testing. If required, moisture content of the coal may be increased by sprinkling water over the coal and thoroughly mixing the coal and applied water together to form a homogeneous mixture.

9. Procedure

9.1 Maintain overnight heating levels so that the temperature of a thermocouple placed on the sole, under the sole cover plate, is near 554°C . As a preliminary to a test, adjust the

automatic controller, if necessary, to maintain this temperature and begin the test as soon as this temperature has been achieved.

9.2 For a single-chamber oven, weigh 13.1 ± 0.02 kg (28.88 ± 0.05 lb) of the prepared sample and transfer completely to a charging hopper. For each chamber of a double-chambered oven, weigh 6.0 ± 0.02 kg (13.23 ± 0.05 lb) of the prepared sample and transfer completely to a charging hopper. Shortly before loading the hopper, collect a small sample of the prepared coal for a moisture determination and place in an airtight container.

9.3 With the sole thermocouple in position and indicating 554°C , remove the sole cover plate, place the hopper containing the weighed quantity of charge over the oven, and allow the coal to fall into the carbonization chamber. Place the automatic temperature program controller into operation at the instant of charging. Use the leveling device, which has been preadjusted, to produce a level coal surface quickly without excess at either end. A further quick adjustment of the leveling device may be necessary at this time.

9.4 Lower the piston onto the surface of the coal charge, taking care to guide it so that desired clearances are maintained on all sides. Then adjust the piston loading apparatus to give a total loading, calculated over the actual area of the piston plate, of 15.17 ± 0.35 kPa (2.20 ± 0.05 psi). Take the reading, defining the initial height of the piston precisely 3 min after the discharge of the coal or blend from the hopper. Place a thermocouple in a thermowell in the vertical hole in the piston and adjust so that the lowest point of the thermowell just touches the top surface of the charge.

9.5 It is informative to have a record of the excursion of the piston during the test. A continuous record with automatic instrumentation is convenient; manual readings every $\frac{1}{2}$ h will usually also be quite adequate. The test is considered to be ended when the thermocouple on the top surface of the coal indicates 500°C . Measure the position of the piston at this moment and consider it as the definitive datum for the calculation of total expansion or contraction. Record the time interval to this point.

9.6 At the end of the test, remove the piston and withdraw the coke. Wirebrush the piston and piston plate and scrape the chamber walls to remove any accumulated carbon or tar. Replace the refractory cover plate and adjust the temperature controller setting for the standby condition.

NOTE 2—At times, with very fluid coals, this fluid coal exudes between the ovenwall and the piston. If this exudate cokes or becomes solid, it may bind the piston to the ovenwall. Should this exuding occur, a knife blade or similar tool should be used to break such bonds so that the movement of the piston is not impaired.

10. Determination of Oven Constants

10.1 In order that the experimental data may be interpreted properly, determine two oven constants. One constant is the average area A of the carbonization chamber, expressed in square metres (square feet). The second constant is the reference height of the top surface of the oven sole. Determine both constants both with temperatures adjusted to the starting condition, that is, with the top surface of the sole at about 554°C .

10.2 Determine the constant A from a series of caliper measurements carried out at each 25.4-mm (1-in.) point of height above the sole. Make five length and ten width measurements, each recorded to 0.8 mm (0.031 in.) at each 25.4-mm level up to 100 mm (4 in.). Average the total data approximately to derive the constant A .

10.3 Determine the reference elevation of the sole or “zero point,” with the piston resting on the sole and loaded to correspond to 15.17 kPa (2.20 psi).

10.4 Redetermine the “zero point” after every 5 tests; redetermine the constant A after every 25 tests.

11. Calculation

11.1 Calculate the basic values BD_t , the bulk density at test conditions in kilograms per cubic metre and, E_t , the percentage expansion at the conditions of test, in percent at BD_t , and M_t , as follows:

$$BD_t = W_t / (A \times h_i) \quad (1)$$

$$E_t = 100 (h_f - h_i) / h_i \quad (2)$$

where:

M_t = moisture content of the sample as charged, %;

W_t = weight of the charge, kg, recorded to 0.023 kg (0.05 lb);

h_i = initial thickness of the coal charged, mm. This is determined from the initial position of the piston on the coal at the start of the test and the reference elevation of the sole or “zero point,” and

h_f = final thickness of the coke. This is determined from the final position of the piston (500°C) and the reference elevation of the sole or “zero point.”

11.2 Record the values of h_i and h_f to 0.25 mm (0.01 in.). Determine the moisture content, M_t , in accordance with Test Method D 3302.

NOTE 3—When working with the double-chambered design, it will be understood that values of the oven constants and M_t , W_t , h_i , and h_f are required for each chamber.

11.3 Positive values of E_t are denoted as expansions, negative values as contractions. Values of E_t are never reported without the concomitant designation of BD_t and M_t .

11.4 Experimental values of E_t at BD_t and M_t may be adjusted by calculation to selected reference bases of bulk density, BD_R , and moisture content, M_R , to give a value E_R . If it has been agreed to adjust values to mutually agreed bases, use the following equation in calculating such adjustments:

$$E_R (\text{at } BD_R, M_R) = [(BD_R / BD_t) / (100 - M_R) / (100 - M_t)] \cdot (100 + E_t) - 100 \quad (3)$$

Reference bases now in use include 55.0, 1.0 and 52.0, 2.0.

11.5 Calculate the expansion or contraction values of individual runs retaining figures to a tenth percentage unit of contraction or expansion.

11.6 Coals containing high inherent moisture should not be corrected to a reference moisture less than the known inherent moisture of the coal.

12. Report

12.1 The final value reported shall be the arithmetic mean the results of accepted determinations expressed to the nearest whole number of percentage expansion or contraction.

13. Precision and Bias

13.1 The results of two determinations with the same apparatus in the same laboratory, calculated at test conditions, shall not differ by more than 3.0 units of expansion or contraction.

13.1.1 A pair of determinations meeting this criterion should be obtained.

14. Keywords

14.1 carbonization; contraction; expansion; fluidity; plasticity; rheology; sole heated oven

ASTM International takes no position respecting the validity of any patent rights asserted in connection with any item mentioned in this standard. Users of this standard are expressly advised that determination of the validity of any such patent rights, and the risk of infringement of such rights, are entirely their own responsibility.

This standard is subject to revision at any time by the responsible technical committee and must be reviewed every five years and if not revised, either reapproved or withdrawn. Your comments are invited either for revision of this standard or for additional standards and should be addressed to ASTM International Headquarters. Your comments will receive careful consideration at a meeting of the responsible technical committee, which you may attend. If you feel that your comments have not received a fair hearing you should make your views known to the ASTM Committee on Standards, at the address shown below.

This standard is copyrighted by ASTM International, 100 Barr Harbor Drive, PO Box C700, West Conshohocken, PA 19428-2959, United States. Individual reprints (single or multiple copies) of this standard may be obtained by contacting ASTM at the above address or at 610-832-9585 (phone), 610-832-9555 (fax), or service@astm.org (e-mail); or through the ASTM website (www.astm.org).