



Designation: D 720 – 91 (Reapproved 1999)

## Standard Test Method for Free-Swelling Index of Coal<sup>1</sup>

This standard is issued under the fixed designation D 720; the number immediately following the designation indicates the year of original adoption or, in the case of revision, the year of last revision. A number in parentheses indicates the year of last approval. A superscript epsilon ( $\epsilon$ ) indicates an editorial change since the last revision or reapproval.

### 1. Scope

1.1 This test method<sup>2</sup> is a small-scale test for obtaining information regarding the free-swelling properties of a coal. The results may be used as an indication of the caking characteristic of the coal when burned as a fuel. This test is not recommended as a method for the determination of expansion of coals in coke ovens.

1.2 The values stated in SI units are to be regarded as the standard. The values given in parentheses are for information only.

1.3 *This standard does not purport to address all of the safety concerns, if any, associated with its use. It is the responsibility of the user of this standard to establish appropriate safety and health practices and determine the applicability of regulatory limitations prior to use.*

### 2. Referenced Documents

- 2.1 *ASTM Standards:*  
D 2013 Method of Preparing Coal Samples for Analysis<sup>3</sup>

### 3. Significance and Use

3.1 This test method, in addition to indicating the caking properties of a coal when burned as a fuel, can be used to give a broad indication of the degree of oxidation of a coal.

### 4. Apparatus

4.1 This test method can be made with either electric or gas heating. When using electric heating, the results obtained must

be the same as those obtained when using the gas heating method. The apparatus common to both electric and gas methods shall consist of the following:

4.1.1 *Crucible*, translucent silica, low-form, with a flat, close-fitting silica ring-handle lid and an extra pierced lid for use in determining the crucible temperature, conforming to the following requirements:

Weight, g	11.0 to 12.75
External height, mm	26 ± 0.5
External diameter at top, mm	41 ± 0.75
Internal diameter at base, min, mm	11
Capacity (approximate), cm <sup>3</sup>	17

4.1.2 *Sight Tube*, as shown in Fig. 1, for viewing the coke buttons so that the effect of parallax will be eliminated. Make the tube of any rigid and preferably opaque material and support vertically on a ring stand.

4.1.3 *Thermocouple and Potentiometer.*

4.1.4 *Weight*, 500 g.

4.2 The electric apparatus shall consist of the following:

4.2.1 *Furnace*, consisting of a base, a heating element, and a chimney. The unit is shown in Fig. 2.

4.2.1.1 *Chimney*—Fig. 2 shows the chimney design. Make the unit from firebrick and coat with firebrick bonding mortar. Maintain the chimney under compression by a sheet-metal envelope (Fig. 2) to prevent cracking. Make the envelope in four pieces, each piece covering a corner. The pieces shall overlap at the center of the flat faces and be held together by bolts and springs. Place two layers of asbestos paper between the chimney brick and the envelope. Cut two grooves in the upper inside chimney walls to accommodate the crucible support. In cases in which the furnace is located in a drafty area, it is advisable to shield the chimney to prevent large fluctuations in furnace temperature.

4.2.2 *Crucible Support*—A convenient crucible support consists of a cradle support made from nickel-chromium wire suspended from a metal ring. The height of the support inside the furnace can be adjusted by loosening the two screws that hold the wire legs of the support in place.

4.2.3 *Electric Controls*, consisting of a rheostat, an a-c ammeter, and two timers. These components shall conform to the following specifications:

<sup>1</sup> This test method is under the jurisdiction of ASTM Committee D-5 on Coal and Coke and is the direct responsibility of Subcommittee D05.15 on Metallurgical Properties of Coal and Coke.

Current edition approved Sept. 15, 1991. Published May 1992. Originally published as D 720 – 43. Last previous edition D 720 – 91(1995).

<sup>2</sup> This test method is an adaptation of the Crucible Swelling Test for Coal of the British Standards Institution. For information concerning the experimental work on which this adaptation is based, see paper by Ostborg, H. N., Limbacker, H. R., and Sherman, R. A., "An Experimental Investigation of the British Standard Method for the Crucible Swelling Test for Coal," *Proceedings, Am. Soc. Testing Mats.*, Vol 42, 1042, p. 851. See also a paper by Selvig, W. A., and Ode, W. H., "An Investigation of a Laboratory Test for Determination of the Free-Swelling Index of Coal," *U.S. Bureau of Mines Report of Investigation 4238*, Revision of R. I. 3989, 1948.

<sup>3</sup> *Annual Book of ASTM Standards*, Vol 05.06.

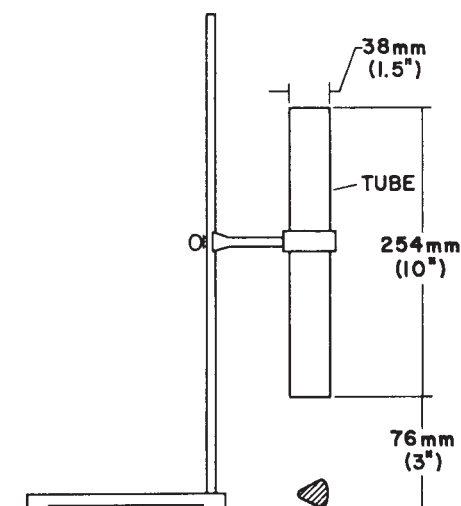

**FIG. 1 Sight Tube**

Ammeter	a-c, 0 to 10-A range
Rheostat	100 W, 10 $\Omega$
Variable transformer	7.4 A, 120 V
Timer	mechanical, 0–5 min minimum span, with a hold position, and electrical contact closed during timing cycle

4.2.3.1 One timer shall actuate the rheostat, at a predetermined setting, after 1½ min of operation. Preset the rheostat to reduce the rate of heating of the furnace so that a temperature of  $820 \pm 5^\circ\text{C}$  ( $1508 \pm 9^\circ\text{F}$ ) is achieved at the end of 2½ min. A variable transformer is desirable for establishing the input voltage to the furnace.

4.3 The gas apparatus shall consist of the following:

4.3.1 *Burner Assembly*—A gas burner with a grid of external diameter, 30 to 42 mm (1.18 to 1.65 in.), a draft shield, and a triangular crucible support as shown in Fig. 3. Make the draft shield, conforming to the dimensions shown in Fig. 3 from the asbestos-cement pipe, and at the top it shall have three slots, 25 mm (1 in.) in depth, in which the wires of the crucible support rest. Support the draft shield on a ring stand, so that the distance between the base of the crucible and the top of the burner grid may be adjusted by raising or lowering the draft shield. Make the triangular crucible support from three pieces of translucent silica tubing each 63 mm (2.5 in.) in length, 6 to 6.5 mm (0.24 to 0.26 in.) in external diameter, and mounted on chromium-nickel wire so that the diameter of the inscribed circle is approximately 32 mm (1.26 in.). The twisted ends of the triangle may be joined together by a loop of wire to facilitate removal of the hot crucible.

4.3.2 *Flowmeter*—A capillary flowmeter with water manometer placed in the gas line before the burner as a guide to the control of the rate of gas flow (Fig. 3).

## 5. Calibration

### 5.1 Electric Furnace:

5.1.1 Turn the main power switch on and set the timer to the HOLD position. Adjust the variable transformer so that the ammeter reads 5.8 A. Allow at least 45 min for the furnace temperature to reach equilibrium.

5.1.2 Set the timer just beyond the 1½-min mark. At 1½ min, lower an empty crucible with pierced lid into the furnace.

Measure the temperature at the inside base of the crucible with a thermocouple and a potentiometer. The unprotected junction of the thermocouple must be in contact with the inside base of the crucible. At the end of 1½ min, the temperature should read  $800 \pm 10^\circ\text{C}$  ( $1472 \pm 18^\circ\text{F}$ ). Adjust the variable transformer as necessary to provide this temperature.

5.1.3 A temperature of  $820 \pm 5^\circ\text{C}$  ( $1508 \pm 9^\circ\text{F}$ ) must be attained at the end of 2½ min. The second timer shall be used here. The control unit rheostat must be properly adjusted to reduce the heating rate at the end of 2½ min. If the rheostat is set initially so that at the end of 1½ min the ammeter reading is reduced by 0.6 or 0.7 A, the specified temperature at the end of 2½ min should be attained. Several trials will no doubt be necessary before the proper temperatures at 1½ and 2½ min are reached; however, the information given above provides a general guide for calibration. The silica crucible and cover must be at room temperature before each calibration run.

5.1.4 After each calibration attempt or sample run, switch the timer to the HOLD position, and allow about 1 min for the furnace to reach equilibrium.

### 5.2 Gas Burner:

5.2.1 With the burner assembly arranged as shown in Fig. 3, and with an empty crucible in position, light the burner about 15 min before making a determination to allow the draft shield to rise to an equilibrium temperature.

5.2.2 After placing a crucible in position adjust the flow of gas and the relative positions of the burner and the draft shield so that the temperature of the inner surface of the bottom of the crucible reaches  $800 \pm 10^\circ\text{C}$  ( $1472 \pm 18^\circ\text{F}$ ) in 1½ min and  $820 \pm 5^\circ\text{C}$  ( $1508 \pm 9^\circ\text{F}$ ) in 2½ min. These desired temperatures may usually be obtained by setting the draft shield so that the bottom of the crucible is approximately 10 mm (0.4 in.) above the burner grid, and then adjusting the gas flame. Determine the crucible temperature by means of a thermocouple and a potentiometer. Insert the thermocouple through the pierced crucible lid so that the unprotected junction of the thermocouple is in contact with the base of the crucible.

## 6. Preparation of Sample

6.1 Grind the sample of coal to pass a 250- $\mu\text{m}$  (No. 60) sieve and prepare it in accordance with the requirements of Method D 2013.

6.1.1 The test should be performed within 24 h of the time that a sample is pulverized to 60 mesh.

NOTE 1—For some coals, size consist of the sample is a variable that can affect the size of the coke button produced.

## 7. Procedure

### 7.1 Preparation of Coke Buttons:

7.1.1 *Electric Method*—Weigh 1 g of the prepared sample into a cold crucible and level by lightly tapping the crucible twelve times on a solid surface, rotating it between taps. Cover the crucible with a solid lid. Set the control-unit timer just past the 1½-min mark and set a separate timer at the 2½-min mark. As the control-unit timer passes the 1½-min mark, lower the crucible into the furnace and at the same time start the 2½-min timer. The rheostat will be actuated at the end of 1½ min. The run will be finished at the end of 2½ min. Remove the coke button carefully and remove the carbon residue remaining in

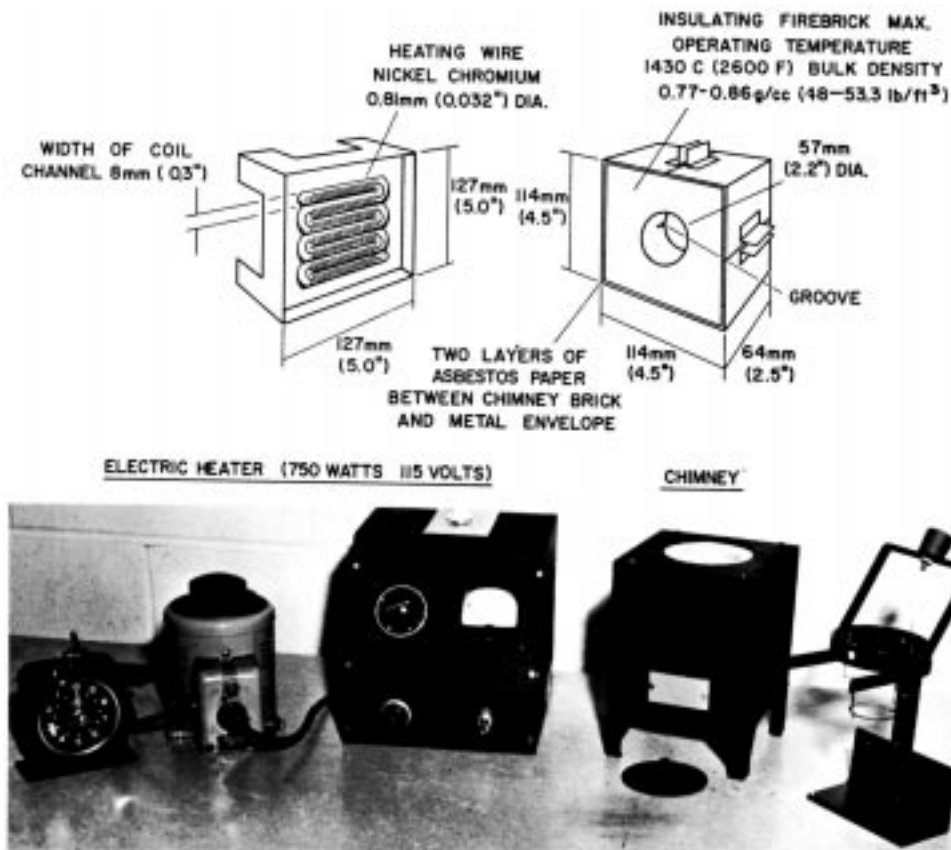

FIG. 2 Furnace Base and Chimney

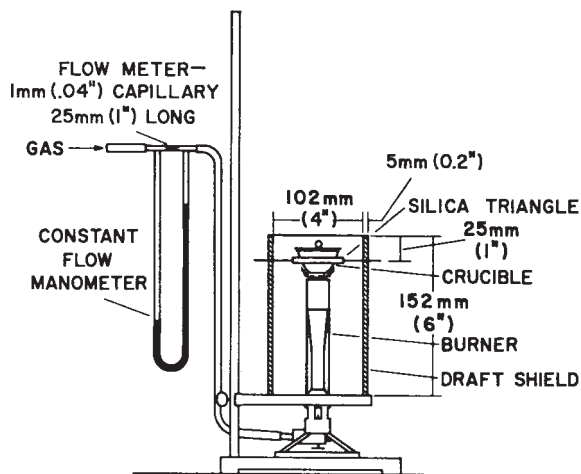

FIG. 3 Details of Burner Assembly

the crucible by ignition. Make three buttons in this manner for each sample of coal tested.

7.1.2 *Gas Method*—Weigh 1 g of the prepared sample into a cold crucible, and level by lightly tapping the crucible twelve times on a solid surface, rotating it between taps. Cover the crucible with a solid lid and place it upright in the silica triangle supported in the draft shield, directly over the gas flame. Heat the covered crucible in the gas flame for the time required for the flame of the burning volatile matter to die out, but in any case for not less than 2½ min. Remove the coke

button carefully and remove the carbon residue remaining in the crucible by ignition. Make three buttons in this manner for each sample of coal tested.

### 7.2 Measurement of Coke Button:

7.2.1 View each coke button through the sight tube and compare it with the series of standard profiles shown in Fig. 4. Place the standard profile with which a button is to be compared exactly in the center of the field of vision as viewed from the top of the tube. Place the button on the profile and rotate it on its axis until, viewed with the eye placed immediately over the top of the tube, the maximum cross-sectional area is obtained. Record the number of the standard profile most nearly matched by the maximum cross-sectional area of the button as the swelling index. If any button deviates by more than one unit from the other two buttons, make a new determination.

7.2.2 Some coals give buttons that do not conform in shape to the standard profiles. For such coals, measure the maximum cross-sectional areas of the buttons and determine the index from the relationship of the areas of the standard profiles to swelling indexes as shown in Fig. 5. For measuring the cross-sectional areas, mount the buttons on graph paper ruled into square centimetres and square millimetres, and trace the outlines of the buttons on the paper while viewing through the sight tube shown in Fig. 1. The buttons may be mounted conveniently by means of modeling clay. The squares inside the outline may be counted, and fractions of squares along the boundary line estimated.

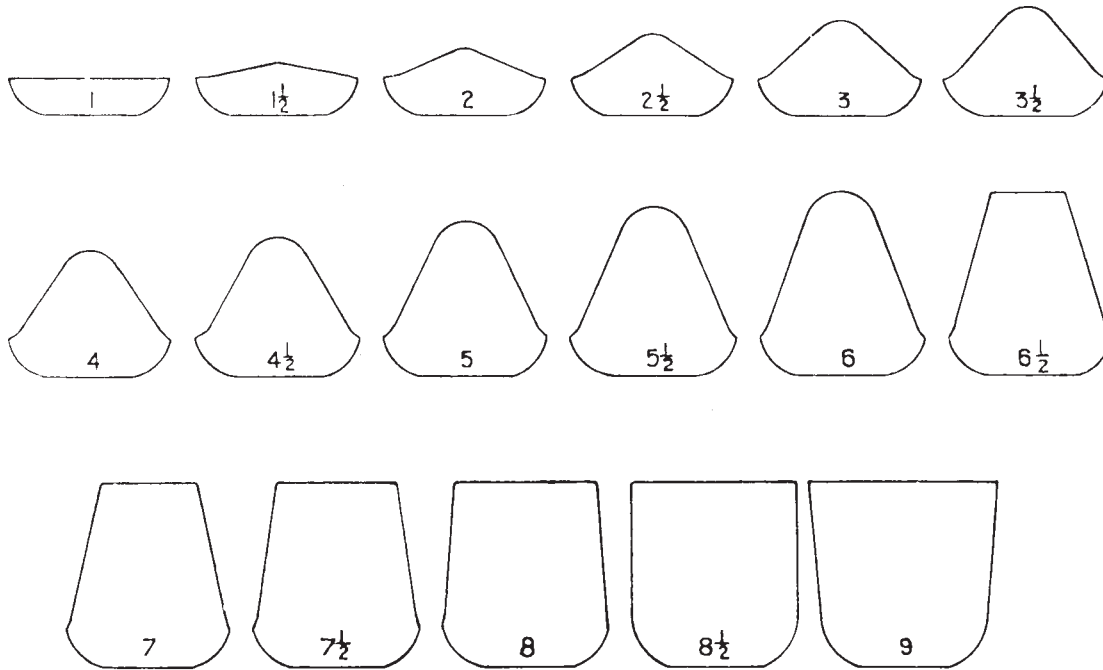

Courtesy of British Standards Institution

FIG. 4 Full-Scale Standard Profiles and Corresponding Index Numbers

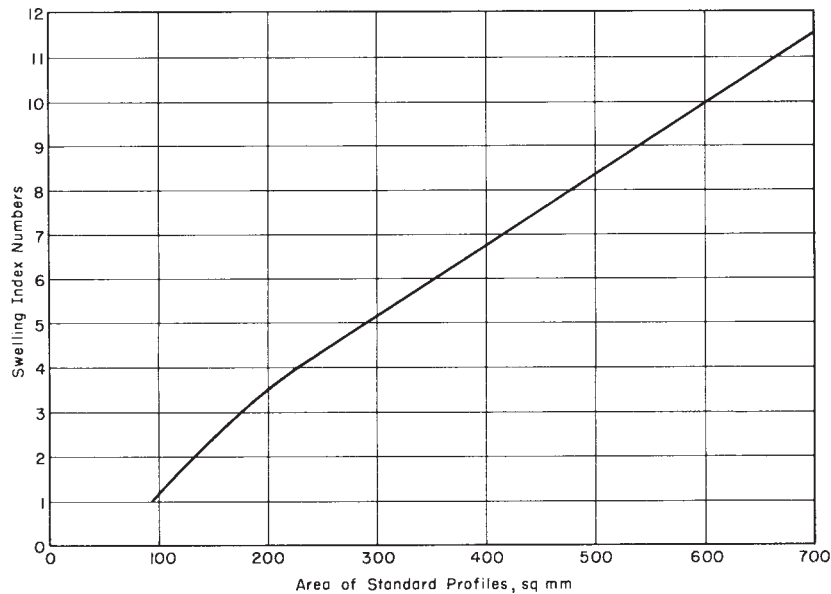

FIG. 5 Relationship of Areas of Standard Profiles to Swelling Indexes

NOTE 2—To take care of buttons whose cross-sectional area is greater than that of standard profile 9, the curve shown in Fig. 5 has been extended to include about 700 mm<sup>2</sup> (1.08 in.<sup>2</sup>) which is the maximum cross-sectional area of the silica crucibles used in the test.

7.2.3 Mechanical or electronic devices may be used to determine the standard profiles if they give results equivalent to those obtained with measurement techniques described in 7.2.1 and 7.2.2.

7.2.4 If the residue is coherent but nonswollen, place it on a flat surface and carefully place a 500-g weight on the button. If

the button disintegrates, report the swelling index as one half. If the button supports the weight or merely cracks into two or three hard coherent pieces, report the number as one.

### 8. Report

8.1 Report the average swelling index of a series of three buttons expressed to the nearest one-half unit. If this test method is to be used for International Classification of hard coal by type, make five buttons. Report the swelling index as zero if the residue from the test sample is noncoherent.

## 9. Precision and Bias<sup>4</sup>

9.1 *Precision*—The relative precision of this test method for the determination of free-swelling index covers the index range from one to nine.

NOTE 3—A test result is considered to be an average of three FSI determinations.

9.1.1 *Repeatability*—The difference in absolute value between two consecutive tests results, carried out on the same sample in the same laboratory by the same operator using the same apparatus, should not exceed the repeatability interval  $I(r)$  more than 5 % of such paired values (95 % confidence level). When such a difference is found to exceed the repeat-

ability interval, there is reason to question one or more of the test results. The repeatability interval for this test method is one.

9.1.2 *Reproducibility*—The difference in absolute value of replicate determinations, carried out in different laboratories on representative samples prepared from the same bulk sample after the last stage of reduction, should not exceed the reproducibility interval  $I(R)$  more than 5 % of such paired values (95 % confidence level). When such a difference is found to exceed the reproducibility interval, there is reason to question one or both of the test results. The reproducibility interval for this test method is two.

9.1.3 *Bias*—Since there is no accepted reference material suitable for determining the bias for the procedure in this test method, bias has not been determined.

## 10. Keywords

10.1 coal; free-swelling index

---

<sup>4</sup> Supporting data are available from ASTM Headquarters. Request RR:D05-1003 and RR:D05-1011.

*ASTM International takes no position respecting the validity of any patent rights asserted in connection with any item mentioned in this standard. Users of this standard are expressly advised that determination of the validity of any such patent rights, and the risk of infringement of such rights, are entirely their own responsibility.*

*This standard is subject to revision at any time by the responsible technical committee and must be reviewed every five years and if not revised, either reapproved or withdrawn. Your comments are invited either for revision of this standard or for additional standards and should be addressed to ASTM International Headquarters. Your comments will receive careful consideration at a meeting of the responsible technical committee, which you may attend. If you feel that your comments have not received a fair hearing you should make your views known to the ASTM Committee on Standards, at the address shown below.*

*This standard is copyrighted by ASTM International, 100 Barr Harbor Drive, PO Box C700, West Conshohocken, PA 19428-2959, United States. Individual reprints (single or multiple copies) of this standard may be obtained by contacting ASTM at the above address or at 610-832-9585 (phone), 610-832-9555 (fax), or service@astm.org (e-mail); or through the ASTM website (www.astm.org).*