



Designation: D 5179 – 9802

# Standard Test Method for Measuring Adhesion of Organic Coatings to Plastic Substrates by Direct Tensile Testing<sup>1</sup>

This standard is issued under the fixed designation D 5179; the number immediately following the designation indicates the year of original adoption or, in the case of revision, the year of last revision. A number in parentheses indicates the year of last reapproval. A superscript epsilon ( $\epsilon$ ) indicates an editorial change since the last revision or reapproval.

<sup>1</sup> This test method is under the jurisdiction of ASTM Committee D1 D01 on Paint and Related Coatings, Materials, and Applications and is the direct responsibility of Subcommittee D01.23 on Physical Properties of Applied Paint Films.

Current edition approved June Dec. 10, 1998, 2002. Published September 1998, February 2003. Originally published as D 5179-91, approved in 1991. Last previous edition approved in 1998 as D 5179 – 97a8.

## 1. Scope

1.1 This test method covers the laboratory determination of organic coating adhesion to plastic substrates by mounting and removing an aluminum stud from the surface of the coating and measuring the force required to break the coating/substrate bond with a tensile tester.

1.2 This test method requires that the aluminum stud be adhered directly to the surface of a coated, cured panel (Fig. 1).

1.3 This test method is used to compare the adhesion of coatings to various plastic substrates, thus allowing for a quantitative comparison of various coating/substrate combinations.

1.4 Other tensile test methods are Test Method D 4541 and ISO 4624 (but are not technically equivalent).

1.5 The values stated in inch-pound units are to be regarded as the standard. The values given in parentheses are for information only.

1.6 *This standard does not purport to address all of the safety concerns, if any, associated with its use. It is the responsibility of the user of this standard to establish appropriate safety and health practices and determine the applicability of regulatory limitations prior to use.*

## 2. Referenced Documents

2.1 *ASTM Standards:*

D 4541 Test Method for Pull-Off Strength of Coatings Using Portable Adhesion Testers<sup>2</sup>

2.2 *Other Standard:*

ISO 4624 Paints and Varnishes—Pull-off test for adhesion<sup>3</sup>

## 3. Summary of Test Method

3.1 An aluminum stud is bonded directly to a coated cured panel. The adhesive is allowed to cure for 2 h at room temperature. The specimen is then subjected to test on a tensile tester equipped with an upper coupling adapter (Fig. 2), and a restraining device (Fig. 3).

3.2 If a coating is to fulfill its function of protecting or decorating a substrate, it must adhere to it for the expected service life. Because the substrate and its surface preparation (or lack of it) has a drastic effect on the adhesion of coatings, a method of evaluation adhesion of a coating to different substrates or surface treatments, or of different coating to the same substrate and treatment, is of considerable usefulness in the industry.

## 4. Significance and Use

4.1 The pull-off strength (commonly referred to as adhesion) of a coating is an important performance property that has been used in specifications. This test method serves as a means for uniformly preparing and testing organic coatings on plastic substrates.<sup>4</sup> Further information may be found in Appendix X1.

<sup>2</sup> *Annual Book of ASTM Standards*, Vol 06.02.

<sup>3</sup> Available from American National Standards Institute (ANSI), 11 W. 42nd St., 4th Floor, New York, NY 10036.

<sup>4</sup> Gray, K. N., Buckley, S. E., and Nelson, G. L., "Accessing Measurement Standards for Coating Adhesion to Plastics," *Modern Paint and Coatings Journal*, Vol 75, No. 10, October 1985, p. 160.

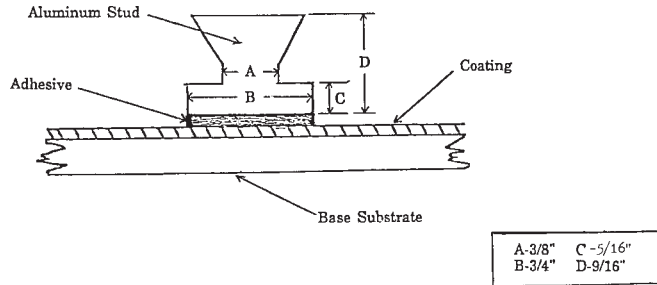

FIG. 1 Direct Tensile Model

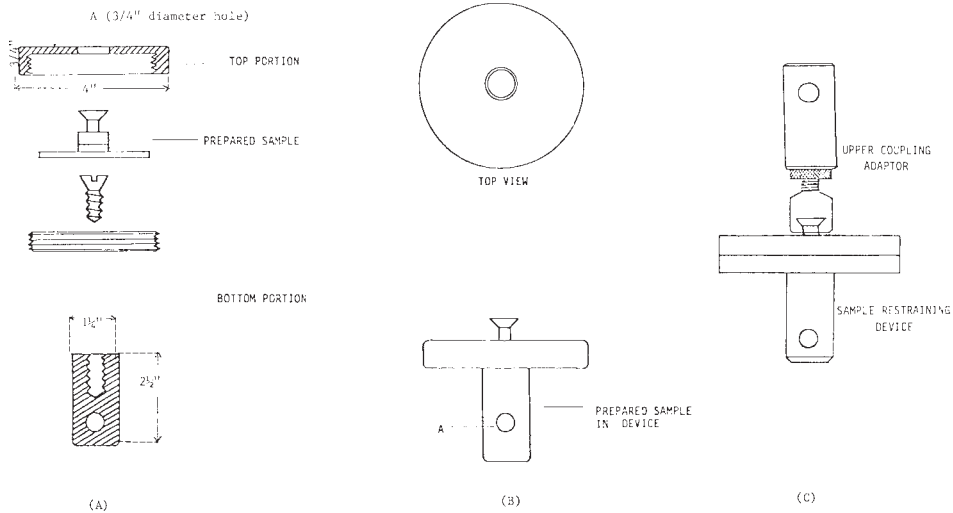

FIG. 3 Direct Tensile Restraining Device

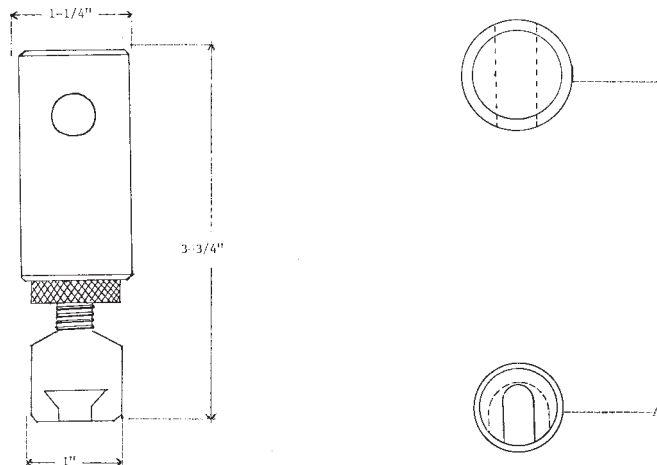

FIG. 2 Upper Coupling Adaptor

5. Apparatus and Materials

5.1 Tensile Tester, commercially available.<sup>5</sup>

5.2 Aluminum Stud—The shape and dimensions of the stud are shown in Fig. 1.

5.3 Upper Coupling Adaptor—The apparatus is shown in Fig. 2. The adaptor is 3 3/4 in. (94 mm) long, 1 1/4 in. (31 mm) in diameter at the top, and 1 in. (25 mm) in diameter at the bottom. The hole, indicated by “B,” is used to attach the adaptor to the tensile tester load cell. The hole has a 1/2-in. (13-mm) diameter. The machined opening indicated by “A,” is to receive the head of the aluminum stud.

<sup>5</sup> The sole source of supply of the wooden puritan applicators, in sizes 6 in. (150 mm) in length and 0.007 in. (2 mm) in diameter, known to the committee at this time is Hardwood Products Co., Guilford, ME 04443. If you are aware of alternative suppliers, please provide this information to ASTM Headquarters, International. Your comments will receive careful consideration at a meeting of the responsible technical committee,<sup>1</sup> which you may attend.

5.4 *Restraining Device*—The apparatus is shown in Fig. 3A and 3B. The ½-in. (13-mm) diameter hole, marked “A,” in the 2 ½-in. (63.5-mm) long, 1 ¼-in. (31-mm) diameter lower coupling adapter, is used to mount the device in the tensile tester. The top portion is 4 in. (100 mm) in diameter, ¾ in. (19 mm) high, and is fitted with a hole slightly larger than ¾ in. (19 mm) in diameter to allow stud clearance. The bottom screw portion is machined to fit with the top portion and is ½ in. (13 mm) thick. Fig. 3C illustrates the final appearance of the test assembly before it is tested.

5.5 *Wooden Applicators*,<sup>5</sup> used to clean the adhesive from around the aluminum stud.

5.6 *Adhesive*, cyanoacrylate adhesive<sup>6</sup>. Since cyanoacrylate adhesives lose adhesive bond strength with time, do not use previously opened containers or lots of adhesive known to be old.

5.7 *Two-Kilogram Weight*, approximately 2 in. (50 mm) in diameter and 5 in. (130 mm) in height.

## 6. Preparation and Conditioning of Specimen

6.1 *Sanding Procedure*—Sand the large face of stud with 80-grit sandpaper, making certain that the surface is uniformly roughened. When sanding studs, sand straight up and down; rotate stud one quarter of a turn and continue sanding. Make certain the surface of the stud is flat but rough. While sanding, keep the stud face parallel to the sandpaper. Nonplanar surfaces cannot be used in testing because they lead to nonuniform bonding of the stud to the coated surface. Only flat (planar) studs should be used in testing. Planarity may be assessed by placing a stud on a flat surface and checking to see if the stud wobbles. Careful preparation of studs is essential for good adhesive adhesion.

6.2 *Cleaning Procedure*—Place sanded studs in a large beaker. Pour technical grade acetone over the studs and swirl the beaker to completely wash the studs. Pour out acetone and repeat the cleaning procedure. Soak the stud for at least 15 min, pour out the acetone, and allow the studs to dry.

6.3 Place washed and dried studs and beaker in an oven at 120°C and allow to heat for 1 h. Remove the beaker and studs from the oven and allow to cool. **DO NOT TOUCH FACE OF STUDS.**

6.4 Spread four drops of cyanoacrylate adhesive on the large face of an aluminum stud. Next, quickly press the stud onto the coated test substrate. Place a 2-kg weight on the stud to ensure good contact between the stud, adhesive, and surface of the coating. Clean the excess adhesive from the edge of the stud with a wooden applicator. Carefully remove the weight after 2 min.

NOTE 1—Substrate panels may be cut to any size that fits the restraining device.

NOTE 2—When the stud is pressed, excess adhesive should escape from under the stud. Excess adhesive buildup at the edge of the stud is a major source of error if allowed to dry. This excess must be removed from around the stud. The adhesive may be removed using a wooden applicator and an absorbent, creped, low-lint material. Some workers have found cotton swabs also work well when removing the excessive adhesive.

6.5 Allow the sample to cure for 2 h at room temperature (see Note 3).

NOTE 3—The time specified led to the results reported in the Precision and Bias Section. If other than the recommended adhesive is used, the user should be guided by the cure time recommended by the adhesive manufacturer. A series of preliminary tests at several cure times may be necessary in the selection of a time that ensures cure of the adhesive used.

NOTE 4—When reusing aluminum studs, the studs must be soaked in acetone to remove the coating and resanded. It has been found that soaking the studs in two separate acetone baths thoroughly removes the adhesive and coating. The first acetone bath is used to dissolve the cyanoacrylate adhesive, and the second is used to further clean and dissolve any coating or adhesive left on the stud. Before the studs are used, they should be resanded and cleaned with acetone as specified in 6.2, 6.3, and 6.4.

6.6 *Conditioning*—Condition the coated substrates for at least 24 h at  $23 \pm 2^\circ\text{C}$  ( $73.5 \pm 3.5^\circ\text{F}$ ) and  $50 \pm 5\%$  relative humidity, and test in the same environment or immediately on removal therefrom, unless otherwise specified by the purchaser and the seller.

## 7. Procedure

7.1 Install the restraining device and upper adaptor in the tensile tester.

7.2 Calibrate the tensile tester. Make sure that the chart speed is set at 8 to 20 in./min (20 to 50 cm/min). Make sure that the crosshead speed is set at 2 in./min (5 cm/min). Make sure that the chart full scale is set at 100 kg.

7.3 Place the specimen to be tested in the restraining device (Fig. 3A and 3B). Pre-position the crosshead and then slowly lower it so the upper coupling adaptor can be attached to the test specimen. Take care to prevent the crosshead from impacting into the top of the specimen. Carefully attach the upper coupling adaptor to the stud (Fig. 3C).

NOTE 5—When testing thin substrates, a piece of plastic may be placed in the restraining device behind the test specimen to prevent the substrate from flexing when the stud is pulled from it.

7.4 Turn on the chart recorder and pen. Start the tensile test. Stop the test when the stress returns to zero on the chart.

7.5 Examine the test area on each specimen to determine the type of coating failure, rating it according to the following:

7.5.1 Adhesive failure of the coating at the substrate, A,

---

<sup>6</sup> Elmer's<sup>®</sup> Wonder Bond Plus<sup>®</sup> Super Glue, a cyanoacrylate adhesive sold by Elmer's Products, Inc., 180 E. Broad St., Columbus, OH 43215, was found acceptable in the round-robin study upon which this test method is based. Other adhesives may be used if they provide adequate adhesion between the aluminum stud and the coating being tested; the results reported in the Precision and Bias Section, however, may not apply. From other work it is noted that some cyanoacrylate adhesives may penetrate certain coatings and soften the coating or the plastic substrate. The same is true for other adhesives. Care in observation of unusual results is necessary to ensure against the possibility of error. This latter is to be suspected if an adhesive gives an unexpectedly low result. Adhesives that yield a brittle adhesive layer should not be used.

7.5.2 Cohesive failure in the coating, *C*,

7.5.3 Combination of adhesive failure at the coating/substrate interface and cohesive failure in the coating, *AC*,

7.5.4 Adhesive failure at the stud, *S*, and

7.5.5 Combination of adhesive failure at the stud and cohesive failure in the coating, *CS*.

7.6 For multilayer coatings, note if the failure is between the layers. If so, label as *CM*.

7.7 Number and retain all test specimens for adhesion failure calculations. Test five specimens of each coated substrate one day and five on a second day. If one specimen differs significantly from the other four at the same time, fails because of an uneven (nonplanar) stud, or for any other reason performs unlike the other four, test a replacement specimen.

NOTE 6—Examine the stud and specimen carefully. Adhesive should have been applied uniformly to the entire stud surface. Coating should have pulled off uniformly over the entire stud surface either with adhesive failure from the substrate (*A*) or cohesive failure in the coating (*C*). If failure is less than 90 % *A* or *C* or (*CM*), if the adhesive has failed at the stud, retest exercising particular care in the specimen and stud preparation.

NOTE 7—The percentage of adhesive failure at the coating/substrate interface is determined by inspecting the tested area on the substrate. This may be assessed by overlaying a transparent sheet grid marked in 0.10-in. (2.54-mm) squares and estimating the percentage of adhesive failure in each square that lies over the tested area. These percentages may then be averaged to obtain failure for each specimen.

NOTE 8—Sample conditioning, if any, and humidity and temperature of test room may affect results. Notation of these conditions should be made on the test report.

**8. Report**

8.1 Report the number of tests, the maximum stress obtained in each test, and the type of failure. Test data sheet is shown in Fig. 4. Fill in data sheet with results obtained from each test. Attach tensile test traces to the data sheets. Calculate and report mean and standard deviation for tensile strength for each coating/substrate combination tested.

**9. Precision and Bias <sup>7</sup>**

9.1 The precision and bias are primarily dependent upon the accuracy of the force measurements, the alignment of the device, the care exercised in stud and specimen preparation, and the care in testing.

9.2 A round robin involving five different types of coatings and seven different plastic substrates, and ten different laboratories yielded interlaboratory reproducibility data as shown in Table 1. Within laboratory repeatability data is shown in Table 2 and Table 3.

9.3 *Bias*—No information can be provided on the bias of this test method for measuring adhesion because no material having an accepted reference value is available.

**10. Keywords**

10.1 adhesion; bond strength; cyanoacrylate adhesive; plastic substrate; pull-off strength; pull testing; tensile tester

<sup>7</sup> A complete report with additional data is available. See Nelson, G. L., "Testing of EMI/RFI Coating Adhesion to Plastics by a Tensile Test Method," *Final Report for Computer and Business Manufacturers Association and Society of the Plastics Industry*, University of Southern Mississippi, June, 1989.

TESTING PROGRAM DATA SHEET														
NAME: _____				ADDRESS: _____										
COMPANY: _____				_____										
	DAY ONE: Date _____						DAY TWO: Date _____							
Material:	Run	A	B	C	D	E	F	Run	A	B	C	D	E	F
	Tensile Str: _____						Tensile Str: _____							
	Type Failure: _____						Type Failure: _____							
	_____						_____							
	_____						_____							
Material:	Run	A	B	C	D	E	F	Run	A	B	C	D	E	F
	Tensile Str: _____						Tensile Str: _____							
	Type Failure: _____						Type Failure: _____							
	_____						_____							
	_____						_____							
Material:	Run	A	B	C	D	E	F	Run	A	B	C	D	E	F
	Tensile Str: _____						Tensile Str: _____							
	Type Failure: _____						Type Failure: _____							
	_____						_____							
	_____						_____							

**FIG. 4 Coating Adhesion Testing by Direct Tensile Methods**

**TABLE 1 Overall Test Reproducibility**

NOTE 1—This data was generated with lesser cautionary language than found in Note 2 and includes laboratories who had not removed excess adhesive. With experienced operators, reproducibility data can be anticipated to be better than shown in Table 1.

Ten Laboratories		
Sample	Kilogram Force	Standard Deviation
1	34.6	6.7
2	36.2	9.3
3	19.8	4.5
4	26.7	8.7
5	31.7	9.9
6	26.0	7.2
7	41.6	9.2
8	16.6	6.5
9	60.5	20.5
10	28.3	9.8

**TABLE 2 Average Tensile Strength Measurements<sup>A</sup>**

NOTE 1—Units for tensile strength and standard deviation are kilograms of force. Multiply by 4.99 to convert to pounds per square inch.

Sample Number		1	2	3	4	5	6	7	8	9	10
Laboratory 1	$\bar{X}$	33.2	32.2	12.9	23.5	25.3	20.8	38.8	5.8	63.9	21.8
	SD <sup>B</sup>	4.3	4.6	2.2	3.5	10.6	3.8	6.3	2.1	12.2	2.5
Laboratory 2	$\bar{X}$	29.2	30.9	19.9	28.0	33.9	22.3	36.8	9.1	80.3	26.0
	SD	5.5	5.8	2.8	3.7	9.2	6.3	7.5	4.0	10.7	5.7
Laboratory 3	$\bar{X}$	33.5	35.7	24.2	32.2	33.8	31.2	49.8	18.6	79.1	39.7
	SD	7.0	4.4	3.9	11.8	5.4	6.4	9.5	4.5	9.6	7.2
Laboratory 4	$\bar{X}$	41.9	45.1	26.2	31.8	43.2	37.2	50.5	17.2	>72.7	33.0
	SD	10.4	4.8	6.1	7.6	6.4	7.7	8.8	5.8	18.7	9.4
Laboratory 5	$\bar{X}$	27.5	23.0	16.7	19.3	24.3	21.1	32.1	26.4	44.6	19.9
	SD	1.1	2.0	3.7	2.2	4.0	2.5	5.3	14.3	11.1	3.1
Laboratory 6	$\bar{X}$	42.4	>41.9	26.2	31.6	48.3	34.1	53.1	23.9	>85.2	33.7
	SD	6.7	5.2	3.0	4.8	6.7	3.5	11.7	6.5	4.8	2.2
Laboratory 7	$\bar{X}$	42.6	42.0	19.0	29.4	31.9	28.9	45.8	16.8	72.4	37.3
	SD	4.1	10.0	2.4	3.7	5.0	4.7	9.9	9.5	26.1	6.3
Laboratory 8	$\bar{X}$	23.2	30.9	18.6	8.6	20.6	21.8	32.8	19.8	32.1	11.2
	SD	5.6	5.1	4.8	1.8	4.7	7.7	9.7	7.5	6.2	2.6
Laboratory 9	$\bar{X}$	34.0	26.4	16.2	25.6	17.4	13.9	27.1	10.4	36.6	20.8
	SD	8.4	8.2	8.8	7.6	2.5	5.3	8.8	5.5	12.4	5.8
Laboratory 10	$\bar{X}$	38.9	53.4	17.6	41.8	38.5	28.5	49.3	18.1	38.4	40.0
	SD	9.9	6.5	2.8	8.7	10.2	9.2	7.4	8.5	14.9	9.0

<sup>A</sup> Each is the average tensile strength using ten samples.

<sup>B</sup> Standard deviation.

**TABLE 3 Average Tensile Strengths, Standard Deviations (SD) and Ranks**

NOTE 1—Units for tensile strength and standard deviation are kilograms of force. Multiply by 4.99 to convert to pounds per square inch.

Sample Number	Coating	Substrate	Failure Mode	Collaborator A			Collaborator B		
				Average	SD	Rank	Average	SD	Rank
1	Lacquer	polymer alloy	C	10.7	3.8	12	12.5	2.5	13
2	Lacquer	polycarbonate resin	A	5.8	1.0	14	8.8	2.4	15
3	Lacquer	ABS <sup>A</sup>	C	10.2	0.8	13	22.8	3.8	12
4	Lacquer	polycarbonate	A	5.4	2.7	15	9.6	1.9	14
5	Lacquer	ABS	C	12.6	3.4	11	24.8	4.5	11
6	Lacquer	PVC <sup>B</sup>	AC	15.4	3.3	10	25.9	3.1	10
7	Enamel	polycarbonate	A	55.6	29.1	5	67.7	9.5	6
8	Urethane	ABS	A	133.5	23.6	2	122.5	24.9	2
9	Urethane	ABS	A	98.9	12.4	3	91.7	16.9	3
10	Urethane	metal	S	133.7	46.1	1	133.4	51.5	1
11	Enamel	metal	A <sup>C</sup>	61.6	14.8	4	75.4	14.3	4
12	Lacquer	GTX 901	C	27.8	4.9	8	62.9	6.8	7
13	Enamel	GTX 901	C	24.7	6.8	9	66.0	17.9	5
14	Enamel	GTX 901	A	40.9	14.1	6	56.0	14.6	8
15	Enamel	GTX 901	A	34.6	10.4	7	50.6	19.1	9

<sup>A</sup> ABS = acrylonitrile butadiene styrene.

<sup>B</sup> PVC = poly(vinyl chloride).

<sup>C</sup> Failure rate is 75 %.

## APPENDIX

### (Nonmandatory Information)

#### X1. COMMENTARY

##### X1.1 Introduction

X1.1.1 Given the complexities of the adhesion process, can adhesion be measured? As Mittal (1-5)<sup>8</sup> has pointed out, the answer is both yes and no. It is reasonable to state that at the present time no test exists that can precisely assess the actual physical strength of an adhesive bond. But it can also be said that it is possible to obtain an indication of relative adhesion performance.

X1.1.2 Practical adhesion test methods are generally of two types: “*implied*” and “*direct*”. “*Implied*” tests include indentation or scribe techniques, rub testing, and wear testing. Criticism of these tests arises when they are used to quantify the strength of adhesive bonding. But this, in fact, is not their purpose. An “*implied*” test should be used to assess coating performance under actual service conditions. “*Direct*” measurements, on the other hand, are intended expressly to measure adhesion. Meaningful tests of this type are highly sought after, primarily because the results are expressed by a single discrete quantity, the force required to fracture the coating/substrate bond under prescribed conditions. Direct tests include certain knife removal methods (2). Common methods which approach the direct test are peel, lap-shear, and tensile tests.

##### X1.2 Test Methods

X1.2.1 In practice, numerous types of tests have been used to attempt to evaluate adhesion by inducing bond rupture by different modes. Criteria deemed essential for a test to warrant large-scale acceptance are: use of a straightforward and unambiguous procedure; relevance to its intended application; repeatability and reproducibility; and quantifiability, including a meaningful rating scale for assessing performance.

X1.2.2 Test methods used for coatings on metals are: peel adhesion or “tape testing”; Gardner impact flexibility testing; and adhesive joint testing including shear (lap joint) and direct tensile (butt joint) testing. These tests do not strictly meet the criteria listed, but an appealing aspect of these tests is that in most cases the equipment/instrumentation is readily available or can be obtained at reasonable cost.

X1.2.3 A wide diversity of test methods have been developed over the years that measure aspects of adhesion (1-5). There generally is difficulty, however, in relating these test to basic adhesion phenomena.

##### X1.3 Direct Tensile Testing

X1.3.1 A long-used approach to coating adhesion testing is the direct tensile test, perhaps “conceptually” the simplest of all methods for measuring adhesion. A dolly or stud is bonded to the coating film. The normally applied force that is required to remove the film is measured. If failure occurs at the substrate/film interface, this force is taken to be the “force of adhesion.” An

<sup>8</sup> The boldface numbers in parentheses refer to the list of references at the end of this test method.

obvious limitation is, of course, the strength of the adhesive bond of the stud to the cured coating. Such methods have been available since the 1930s. Many of these test methods have unfortunately suffered from their own lack of reproducibility. This is not unexpected since the forces involved are not quite as simple as appearance would have it.

X1.3.2 It is essential that the force be applied strictly in the direct normal to the sample and that no bending moment is active across the test area. Deviations from symmetry in the test arrangement, poor alignment, deviations from homogeneity and of thickness of the adhesive/coating, and random variations in the strength of the bond between firm and substrate affect test results.

X1.3.3 The stress at locations where the adhesive film is thinner will be higher than the average stress and will be transmitted to the firm under test. Another factor may be peeling during test, which is not easily identified or analyzed.

X1.3.4 The adhesive used to bond a stud to the coating has the potential to influence the coating film properties by penetration through the film into microcracks and possibly into the substrate. Test adhesive flexibility may also be an issue, as well as the flexibility of the substrate, if the sample is unrestrained. Some adhesives, including cyanoacrylate adhesives, may attack some coatings resulting in a loss of adhesion.

X1.3.5 There exist now within ASTM both laboratory and field versions of direct tensile-tests for coatings. This test method, D 5179, while limited to organic coatings on plastics, uses a restrained sample and commonly available tensile test apparatus. The second, Test Method D 4541, defines a class of portable pull-off adhesion testers for field evaluation of coating adhesion. Test Method D 5179 is the successor to numerous attempts to develop a reproducible coating tensile test and was approved in 1991.

#### **X1.4 Test Method D 5179**

X1.4.1 As stated in 1.1, this test method covers the laboratory determination of adhesion of organic coatings to plastic substrates by mounting and removing an aluminum stud from the surface of a coating and measuring the force required to break the coating/substrate bond with a tensile tester. This test method provides an inexpensive test assembly that can be used with most tensile test machines. The method is used to compare the pull-off strength (commonly referred to as adhesion) of coatings to various plastic substrates, thus allowing for a quantitative comparison of various coating/substrate combinations.

X1.4.2 Again, as stated in 3.1, a carefully prepared aluminum stud is bonded directly to a coated, cured panel using a cyanoacrylate adhesive. The adhesive is allowed to cure for 2 h at room temperature. Adhesive buildup is removed from around the stud. The specimen is then subjected to test on a tensile tester equipped with an upper coupling adapter and a restraining device to provide for sample alignment and minimal substrate flexing. The sample bearing the stud is installed in the restraining device, with only the stud protruding. The tensile machine crosshead is lowered so the upper coupling adaptor can be attached to the specimen.

X1.4.3 When testing thin substrates, a piece of plastic is placed in the restraining device behind the specimen to ensure a rigid assembly. The tensile test is conducted, and pull strength recorded. Each specimen is rated according to the type of coating failure.

X1.4.4 For multilayer coatings, failure between the layers is noted and labeled. Five specimens of each coated substrate are tested one day and five on a second day. If one specimen differs significantly from the other four tested at the same time, fails because of an uneven (nonplanar) stud, or for another reason performs unlike the other four, a replacement specimen is tested. The stud and specimen are carefully examined. The adhesive should have been applied uniformly to the entire stud surface. Coating should have pulled off uniformly over the *entire* stud surface either with adhesive failure from the substrate (*A*) or cohesive failure in the coating (*C*). A retest is performed exercising particular care in specimen and stud preparation, if failure is less than 90 %, see *A* or *C* (or *CM*), or if the adhesive has failed at the stud. Pull strength for the ten runs on each coating substrate combination are averaged and reported.

X1.4.5 The precision and bias are primarily dependent upon the accuracy of the force measurements, the alignment of the device, the care exercised in stud and specimen preparation, and in the care in testing. A ten-laboratory round robin on ten samples gave an average standard deviation of 29 % for reproducibility and 22 % for repeatability. A range of pull strengths of two orders of magnitude has been observed for diverse coating plastic combinations.



**REFERENCES**

- (1) Mittal, K. L., “Adhesion Measurement: Recent Progress, Unsolved Problems, and Prospects,” “Adhesion Measurement of Thin Films, Thick Films, and Bulk Coatings,” *ASTM STP 640*, ASTM, 1978, pp. 7–8.
- (2) Corcoran, E. M., “Adhesion,” Chapter 5.3, *Paint Testing Manual*, 13th ed., *ASTM STP 500*, ASTM, 1972, pp. 314–332. See also the 14th ed., 1995.
- (3) Gardner, H. A., and Sward, G. G., *Paint Testing Manual*, 12th ed., Chapter 7, Gardner Laboratory, Bethesda, MD, 1962, pp. 159–170.
- (4) Mittal, K. L., *Journal of Adhesion Science and Technology*, Vol 1, No. 3, 1987, pp. 247–259.
- (5) Stoffer, J. O., and Gadodia, S. K., *American Paint and Coatings Journal*, Vol 70, Nos. 50 and 51, 1991, pp. 36–40 and 36–51, respectively.

*ASTM International takes no position respecting the validity of any patent rights asserted in connection with any item mentioned in this standard. Users of this standard are expressly advised that determination of the validity of any such patent rights, and the risk of infringement of such rights, are entirely their own responsibility.*

*This standard is subject to revision at any time by the responsible technical committee and must be reviewed every five years and if not revised, either reapproved or withdrawn. Your comments are invited either for revision of this standard or for additional standards and should be addressed to ASTM International Headquarters. Your comments will receive careful consideration at a meeting of the responsible technical committee, which you may attend. If you feel that your comments have not received a fair hearing you should make your views known to the ASTM Committee on Standards, at the address shown below.*

*This standard is copyrighted by ASTM International, 100 Barr Harbor Drive, PO Box C700, West Conshohocken, PA 19428-2959, United States. Individual reprints (single or multiple copies) of this standard may be obtained by contacting ASTM at the above address or at 610-832-9585 (phone), 610-832-9555 (fax), or [service@astm.org](mailto:service@astm.org) (e-mail); or through the ASTM website ([www.astm.org](http://www.astm.org)).*