



Designation: E 2302 – 03a

## Standard Test Method for Measurement of the Luminance Coefficient Under Diffuse Illumination of Pavement Marking Materials with CEN- Prescribed Geometry Using a Portable Reflectometer<sup>1</sup>

This standard is issued under the fixed designation E 2302; the number immediately following the designation indicates the year of original adoption or, in the case of revision, the year of last revision. A number in parentheses indicates the year of last reapproval. A superscript epsilon ( $\epsilon$ ) indicates an editorial change since the last revision or reapproval.

### 1. Scope

1.1 This test method covers measurement of the luminance coefficient under diffuse illumination of horizontal pavement markings, such as traffic stripes and surface symbols, and pavement surfaces, in a particular viewing direction using a portable reflectometer.

NOTE 1—The luminance coefficient under diffuse illumination is a measure of the reflection of horizontal pavement markings and pavement surfaces in a particular viewing direction in daylight or under road lighting. Diffuse illumination approximates daylight illumination from the overcast sky, and road lighting as an average of locations on the pavement surface.

1.2 The co-viewing angle of the reflectometer affects the readings. As specified by the European Committee for Standardization (CEN), the co-viewing angle shall be  $2.29^\circ$ .

1.3 This test method is intended to be used for field measurement of pavement markings and pavement surfaces but may be used to measure the performance of materials on sample panels before placing the marking material in the field.

1.4 *This standard does not purport to address all of the safety concerns, if any, associated with its use. It is the responsibility of the user of this standard to establish appropriate safety and health practices and determine the applicability of regulatory limitations prior to use.*

---

<sup>1</sup> This test method is under the jurisdiction of ASTM Committee E12 on Color and Appearance and is the direct responsibility of Subcommittee E12.10 on Retroreflection. Current edition approved July 10, Dec. 1, 2003. Published September December 2003. Originally approved in 2003. Last previous edition approved in 2003 as E 2302 – 03.

## 2. Referenced Documents

### 2.1 ASTM Standards:<sup>2</sup>

E 284 Terminology of Appearance

E 809 Practice for Measuring Photometric Characteristics of Retroreflectors

### 2.2 Other Standard:

CEN EN 1436 Road Marking Materials—Road Marking Performance for Road Users<sup>3</sup>

## 3. Terminology

3.1 The terminology used in this test method generally agrees with that used in Terminology E 284.

### 3.2 Definitions:

3.2.1 *luminance coefficient under diffuse illumination; Qd, n*—the ratio of luminance, L, in a particular viewing direction, of a projected surface to the illuminance of diffuse illumination, E, at the surface on the plane of the surface, expressed in candelas per square metre per lux ( $\text{cd}\cdot\text{m}^{-2}\cdot\text{lx}^{-1}$ ).

3.2.1.1 *Discussion*—Qd has a range from zero up to a maximum of  $1/\pi =$  approximately  $0.318 \text{ cd}\cdot\text{m}^{-2}\cdot\text{lx}^{-1}$ . For convenience, the units used commonly are millicandelas per square metre per lux ( $\text{mcd}\cdot\text{m}^{-2}\cdot\text{lx}^{-1}$ ) providing a range from zero up to  $1000/\pi =$  approximately  $318 \text{ mcd}\cdot\text{m}^{-2}\cdot\text{lx}^{-1}$ .

3.2.2 *co-viewing angle, a, n*—the angle between the plane of the pavement marking surface and the observation axis.

3.2.3 *portable reflectometer, n*—a hand-held instrument that can be used in the field or laboratory for measurement of luminance coefficient under diffuse illumination.

3.2.4 *instrument standard, n*—working standard used to standardize the portable reflectometer.

## 4. Summary of Test Method

4.1 This test method involves the use of commercial portable reflectometers for determining the luminance coefficient under diffuse illumination in a particular viewing direction of horizontal coatings materials used in pavement markings.

4.2 The co-viewing angle is fixed at  $2.29^\circ$ .

4.3 The reflectometers use an external panel or other instrument standard of known luminance coefficient under diffuse illumination, Qd.

4.4 The portable reflectometer is placed directly over the pavement marking to be measured, ensuring that the measurement area of the reflectometer fits within the width of the stripe, and the reading displayed by the reflectometer is recorded.

4.5 Readings shall be taken ~~and averaged~~ for the direction of traffic. Readings shall be taken for each direction of traffic ~~and averaged~~ separately for centerlines.

## 5. Significance and Use

5.1 The quality of the stripe for visibility in daylight or under road lighting is determined by the luminance coefficient under diffuse illumination, Qd, and depends on the materials used, age, and wear pattern. These conditions shall be observed and noted by the user.

5.2 Under the same conditions of illumination and viewing, higher levels of Qd correspond to higher levels of lightness.

5.3 Reflectivity of pavement (road) markings degrade with traffic wear and require periodic measurement to ensure that sufficient line visibility is provided to drivers.

5.4 For a given viewing distance, measurements of Qd made with a reflectometer having a geometry corresponding to that distance are a good indicator of the visual ranking of material measured.

5.5 specified by CEN, the measurement geometry of the instrument is based on a viewing distance of 30 m and an eye height of 1.2 m.

5.6 It shall be the responsibility of the user to employ an instrument having the specified co-viewing angle.

## 6. Apparatus

### 6.1 Portable Reflectometer:

6.1.1 The reflectometer shall be portable, with the capability to be placed on various horizontal pavement markings in different locations.

6.1.2 The reflectometer shall be constructed so that placement on the highway pavement markings will preclude any stray light entering the measurement area of the instrument and affecting the reading. This may be done by shielding against stray light, or by subtraction of the stray light reading, or both. Alternatively, the reflectometer shall produce a warning signal when stray light could affect the reading.

6.1.3 For the convenience of the user, a marking shall be placed on the instrument to permit it to be aligned with the direction of traffic, or the instrument design shall itself indicate the measuring direction in an obvious manner.

<sup>2</sup> For referenced ASTM standards, visit the ASTM website, [www.astm.org](http://www.astm.org), or contact ASTM Customer Service at [service@astm.org](mailto:service@astm.org). For Annual Book of ASTM Standards, Vol 06.01, volume information, refer to the standard's Document Summary page on the ASTM website.

<sup>3</sup> Available from European Committee for Standardization, Central Secretariat (CEN), rue de Stassart 36, B1050 Brussels, Belgium.

6.2 Illumination System Requirements :

6.2.1 The illumination system shall provide diffuse illumination, which can be obtained by indirect illumination through a sample gate from a photometric sphere of interior white, matt finish.

6.2.2 The illumination system shall have compensation for the increase of illumination caused by interreflection between a sample surface and the interior surfaces of the illumination system, for instance by means of a reading of the illuminance at a location close to the sample gate.

6.2.3 ~~A~~ The diffuse illumination may be approximated by reflection from the interior surface of sphere or other shape or by other means. Enough testing shall be carried out to verify that flux received on the sample is approximately homogeneous. For measurements from all positions in the sample gate and in all directions, using a collection cone of an included angle of 8 degrees the ratio of the smallest to the largest measurement shall be minimum 0.8. The test shall be carried out with the sample gate open, and shall be repeated with the sample gate closed by a reflecting surface of white, matt finish with suitable openings to allow for the measurements.

6.2.3.1 The case of illumination by a sphere with a bottom aperture such as is shown in Fig. 1 is suitable for the purpose. The bottom aperture is closed by a bottom surface with a. For this arrangement sample gate, whose design is open for various considerations. The sample gate should not be larger than necessary in view of the illuminated area needed according to in accordance with 6.4 and should stop at a distance before the sphere surface opposing the observation direction. In order that reflection in the sample surface shall not distort the uniformity of luminance of the interior sphere surface, the remaining part of

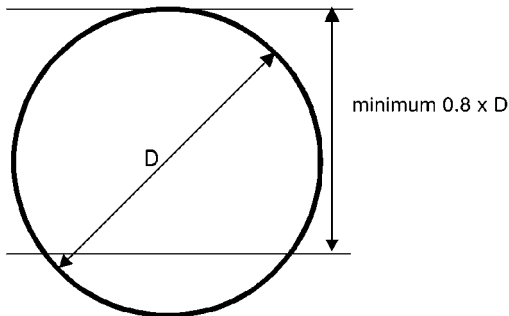

FIG. 1a Part of a sphere

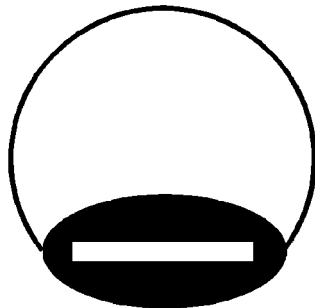

FIG. 1b Bottom aperture closed by a bottom surface with a sample gate

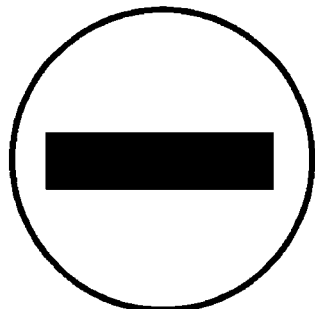

FIG. 1c Bottom surface with a sample gate

FIG. 1 Illumination System for a Portable Reflectometer: a) Part of a Sphere; b) Bottom Aperture Closed by a Bottom Surface with a Sample Gate; c) Bottom Surface with Sample Gate

the sphere, after introducing the bottom aperture, shall be minimum  $0.8 \times D$ , where  $D$  is the diameter of the sphere. ~~The direct illumination shall cover all of~~ In this case, the remaining part test of the sphere 6.2.3 needs only to be applied with such a degree of uniformity that the ratio of the smallest to the largest luminance of the interior sphere surface is minimum 0.8, when measured in directions through the center of the sample gate with a circular measuring field of diameter of  $0.1 \times D$ . open.

6.2.4 The sphere may be approximated by other shapes, but enough testing shall be carried out to verify that interior surfaces have approximately constant luminance. The ratio of the smallest to the largest luminance of interior surfaces shall be minimum 0.8, when measured in different directions through different locations at the sample gate. The test shall be carried out with the sample gate open, and shall be repeated with the sample gate closed by a reflecting surface of white, matt finish with suitable openings to allow for the measurements.

6.3 Receiver Requirements:

6.3.1 The receiver shall have sufficient sensitivity and range to accommodate luminance coefficient in diffuse illumination expected in use, typically from 1 to close to the maximum of approximately  $318 \text{ mcd}\cdot\text{m}^{-2}\cdot\text{lx}^{-1}$ .

6.3.2 The combined spectral distribution of the illumination and the spectral responsivity of the receiver shall match the combined spectral distribution of CIE Illuminant D65 and the  $V(\lambda)$  spectral luminosity function according to the following criterion: For any relevant choice of plano parallel colored absorptive filter mounted in the path of light to the detector, when measuring a white reflective sample or calibration standard, the ratio of the  $Q_d$  measured with the filter to the  $Q_d$  measured without the filter shall be within 10 % of the Illuminant D65 luminous transmittance of the filter. See Fig. 2 for the position of the absorptive filter. Relevant absorptive filters shall include at least a yellow filter of color at about the acceptable limit toward green and a yellow filter of color at about the acceptable limit toward red.

NOTE 2—Absorptive long pass filters with pass wavelengths at about 515 nm and 550 nm are commercially available and correspond to greenish yellow and reddish yellow. Illuminant D65 luminous transmittance values must be derived by measurement of the individual filters, but typical values are given below.

Filter Type and Thickness	1 mm	2 mm	3 mm
515 nm	0.803	0.777	0.758
550 nm	0.574	0.546	0.489
550 nm	n/a	n/a	0.489

6.3.2.1 If the instrument is intended to be used for materials of other colors, relevant absorptive filters shall include filters of such colors. It is recommended to test also the response to infrared radiation by means of an infrared absorptive filter, and to request that the  $Q_d$  measured with the filter is small.

NOTE 3—Some combinations of light sources and detectors tend to give response to infrared radiation. An absorptive long pass filter with pass wavelength at about 715 nm is suitable. The  $Q_d$  measured with the filter inserted should theoretically be zero, but a value from  $-3$  to  $3 \text{ mcd}\cdot\text{m}^{-2}\cdot\text{lx}^{-1}$  is acceptable.

6.3.3 The receiver may be either at optical infinity or at a finite distance from the measurement area, and the co-viewing angle shall be  $2.29 \pm 0.025^\circ$  as determined from the center of the measurement area. See Fig. 3 for a diagram of the optics geometry. The co-viewing angle can be tested with light through the aperture stop at the detector, using a frame with pinholes and targets as shown in Fig. 4. For a non-collimated instrument, the pinholes shall be at a location corresponding to the center of the measurement field.

NOTE 4—To send light through the aperture stop at the detector involves opening of the reflectometer, which should be done according to instructions by the manufacturer of the reflectometer.

6.3.4 As determined from the center of the measurement area, the aperture of the receiver shall not be larger than a square

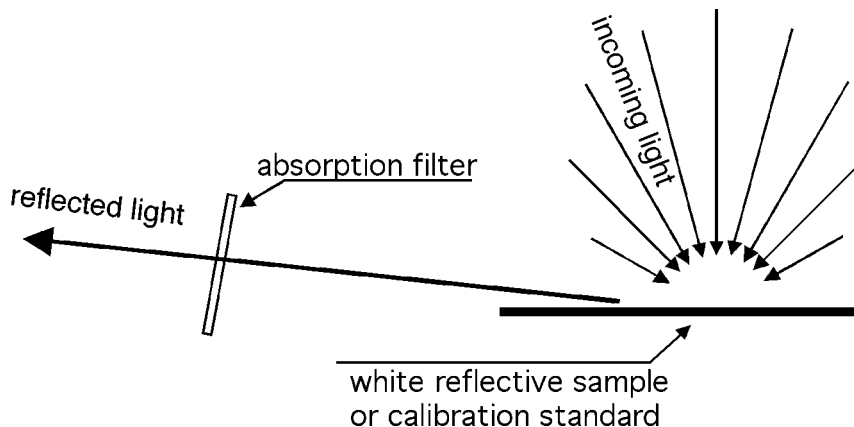

FIG. 2 Use of Absorptive Filter and White Reflective Sample or Calibration Standard to Test the Spectral Responsivity of the Receiver

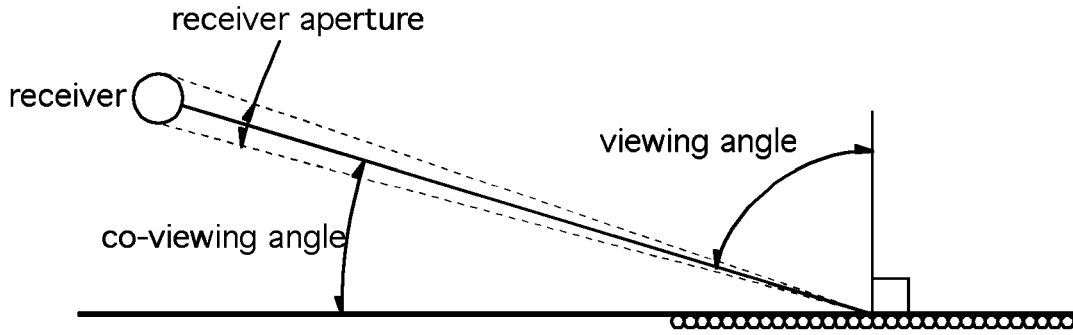

FIG. 3a Angle and aperture for non-collimating portable reflectometer is determined from the center of the sample measurement area.

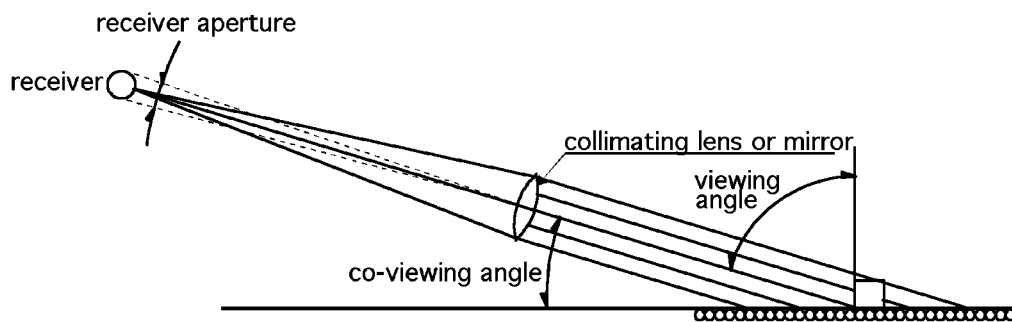

FIG. 3b Angle and aperture for collimating portable reflectometer is equal for all points of the sample measurement area.

FIG. 3 Optics Geometry Diagram for Portable Reflectometer: a) Angle and Aperture for Non-Collimating Portable Reflectometer; b) Angle and Aperture for Collimating Portable Reflectometer

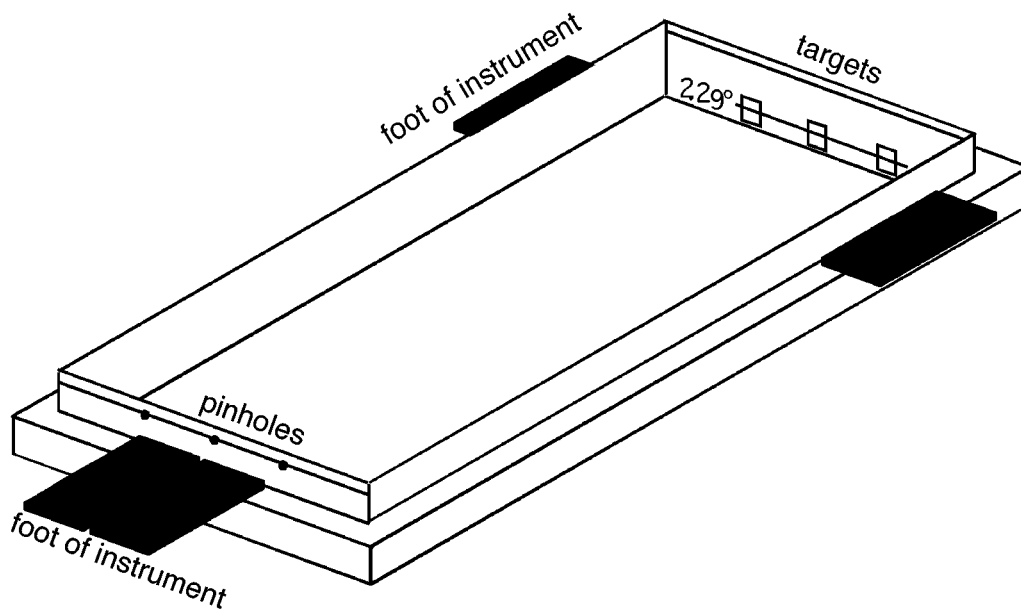

FIG. 4 Frame with Pinholes and Targets for Alternative Testing of the Co-viewing Angle and the Aperture for Only the Collimated Instruments

subtending 20 min of arc ( $0.33^\circ$ ) in both horizontal and vertical directions. For a collimated instrument, the frame shown in Fig. 4 can also be used to test the aperture angle, when the targets indicate maximum dimensions.

NOTE 5—The maximum receiver aperture dimensions are in agreement with CEN EN 1436.

6.3.5 The combined stability of the output of the light source and the receiver shall be such that readings will not change more than  $\pm 1\%$  after 10 s when the reflectometer is in contact with the pavement marking and ready to measure.

6.3.6 The linearity of the reflectometer photometric scale over the range of readings expected shall be within 2%. Correction factors may be used to ensure a linear response. A method for determining linearity is found in Annex A2 of Practice E 809.

6.3.7 The reflectometer shall have a zero-adjust control, or an auto-zero function.

6.4 *Measurement Geometry:*

6.4.1 ~~The measurement detected area and the illuminated area shall either be according to arrangement A—the measurement area is fully included within the illuminated area; or arrangement B—the A) or the illuminated area is shall be fully included within the measurement area—detected area (called arrangement B).~~

NOTE 6—Arrangement A is advantageous to arrangement B in the sense that it leads to less variation of the measured Qd value with small tilts of the reflectometer that are unavoidable in practical field measurements.

6.4.2 The smaller of the two areas, ~~measurement area detected~~ or illuminated area, is the measurement area and shall be minimum at least 50 cm<sup>2</sup>. See Fig. 5 for a method of testing this area.

NOTE 7—The plate mentioned in Fig. 5 needs in most cases to be a glass plate with a diffuse upper surface, so that the area can be studied from the underside.

6.4.3 The larger of the two areas, illuminated or ~~measurement detected~~ area, shall be large enough and have spatially uniform characteristics (either illumination or sensitivity) such that Qd values measured on a non-glossy reflective surface shall vary at most  $\pm 10\%$ , when the height position between surface and reflectometer H is changed from 0 mm to -1 mm, 1 mm or 2 mm. This may be performed in the dark. See Fig. 6 for a method of testing the variation.

NOTE 8—Shifts in height positions and tilts of a reflectometer are unavoidable in practical field measurements due to surface texture, particles on the surface, vertical curve of the pavement marking or profile. A reflectometer must have some reserve for practical conditions. Profiled pavement markings require even larger reserves, when profiles are higher than 2 mm, to be able to measure reliably the Qd values of such pavement markings.

**7. Standardization**

7.1 The reflectometer shall be standardized using an instrument standard consisting of a separate panel or other instrument standard with a known and reproducible luminance coefficient under diffuse illumination measured at the same geometry as used in the portable reflectometer. The instrument standard shall be standardized with diffuse illumination from an indirectly illuminated photometric sphere of sufficient dimensions, with the datum mark indicated on the standard. The instrument standard shall have a standardization value of the luminance coefficient under diffuse illumination, Qd, within the range of expected pavement markings. The standardization values shall be maintained by checking against other standards, or by standardization sufficiently often to ensure that no large uncertainties can occur. See Fig. 7 for a method of providing diffuse illumination on panels.

7.2 Subsequent to this standardization, an internal or secondary reference surface or standard may be used to maintain the standardization of the instrument during brief periods of transport to the test site area.

7.3 Note that transporting the instrument from an air conditioned area to the test site may result in fogging of mirrors or glass surfaces (if any) in the instrument. If there is any doubt concerning the calibration or the readings are not constant, allow the instrument to reach ambient conditions and recalibrate with the instrument standard.

**8. Procedure**

8.1 Follow the manufacturer’s instructions for operation of the reflectometer, which generally uses the following procedure:

8.1.1 Ambient temperature shall not be less than 4°C (40°F).

8.1.1.1 Transporting the instrument from an air conditioned area to the test site may result in fogging of mirrors or glass surfaces (if any) in the instrument.

8.1.2 The surface of the marking shall be clean and dry with no ice.

8.1.3 Turn on the reflectometer, and allow it to reach equilibrium following the manufacturer’s instructions.

8.1.4 If the reflectometer has a zero-adjust control, set the display to  $0 \pm 2$  in the least significant digit, with the instrument placed on a very black low reflectance panel.

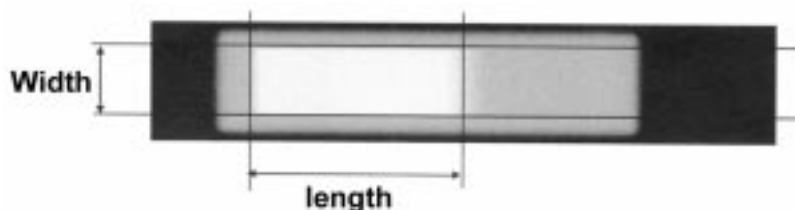

**FIG. 5** With Light through the Aperture Stop at the Detector, the Measurement and Illuminated Areas are Projected onto a Plate against the Feet of the Instrument. The Smaller Area is Measured from “Middle of Blur” to “Middle of Blur”

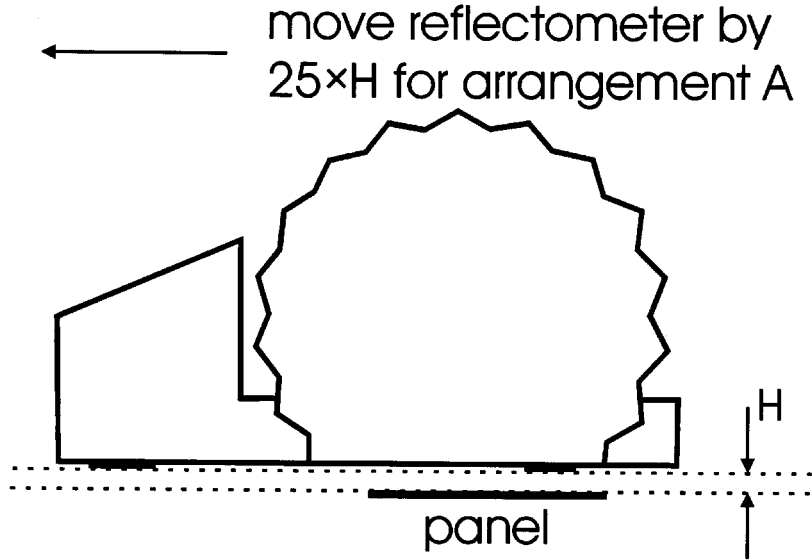

FIG. 6 Lift Test for a Portable Reflectometer. For Arrangement A (Measurement Area Included within the Illuminated Area) the Reflectometer is Moved Backwards in Proportion to the Height Position H in Order to Keep the Measurement Area at a Fixed Position on the Surface

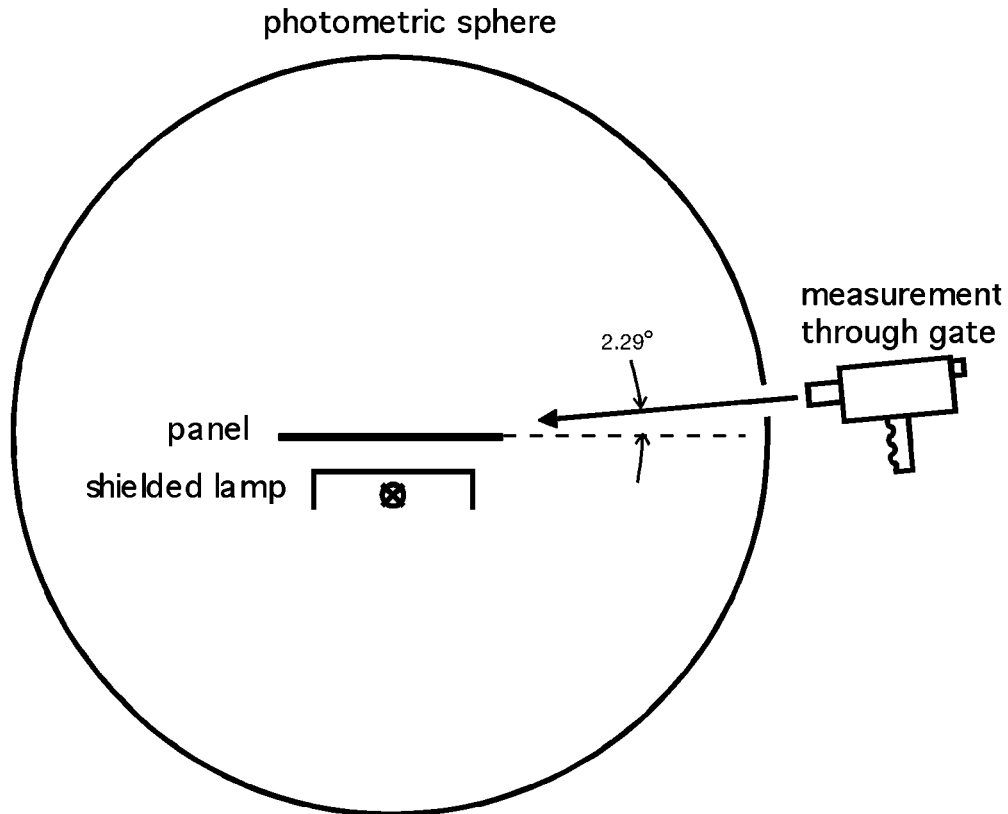

FIG. 7 A Panel Placed in a Photometric Sphere Receives Diffuse Illumination from the Upper Part of the Photometric Sphere, which is Indirectly Illuminated by a Shielded Lamp below the Panel. The Luminance of the Panel Surface can be Measured through a Gate in the Sphere

8.1.5 If a standard panel or other instrument standard is used, standardize the reflectometer by placing it on the instrument standard and setting the standardization control to the standardized value.

8.1.6 For instruments with an internal reference surface, insert that surface into the light path and read the signal from the display. Record this reading.

8.1.7 Place the reflectometer squarely on the pavement marking material, ensuring that the measurement area of the reflectometer fits within the width of the stripe. The reading direction of the reflectometer shall be placed in the direction of traffic. Readings shall be taken for each direction of traffic ~~and averaged~~ separately for centerlines.

8.1.8 Record the reflectometer reading, and then move to other locations on the sample set separated sufficiently to provide meaningful data (typically 1 metre), and record the results.

8.1.9 At intervals of one hour or less, check the standardization and readjust the setting if the reading of either the internal standard or the instrument standard has changed by more than 5 %.

## 9. Test Report

9.1 Include the following data in the test report:

9.1.1 Test date.

9.1.2 Average of the readings at each test location expressed as millicandelas per square metre per lux ( $\text{mcd}\cdot\text{m}^{-2}\cdot\text{lx}^{-1}$ ). The average shall be reported for each traffic direction for centerlines.

9.1.3 Geographical location of the test site, including distance from nearest permanent site identification, such as a mileage marker or crossroad.

9.1.4 Identification of the pavement marking material tested: type, color, age, and transverse location on road (edge line, first line, second line, and center).

9.1.5 Identification of the instrument used.

9.1.6 Value and date of standardization of the instrument panel or other standard used.

9.1.7 Remarks concerning the overall condition of the line, such as rubber skid marks, carryover of asphalt, snow plough damage, and other factors that may affect the reflection measurement.

9.1.8 Ambient temperature.

## 10. Sources of Error

10.1 There are many factors that cause variability when taking readings in the field. Some of these are as follows:

10.1.1 Slight changes in the position of the reflectometer on the traffic line may yield different readings.

10.1.2 Transverse lines may yield less uniform readings than longitudinal lines. Transverse lines have high wear in the wheel track area and less wear in the non-wheel track area.

10.1.3 Population and clarity of glass beads will affect the readings.

10.1.4 The pigment loading of the binder, road films, dirt, salt, dust, water, etc. will also affect the readings.

10.1.5 The co-viewing angle with respect to the specimen plane will be affected by the physical characteristics of the specimen.

## 11. Precision and Bias

11.1 These data are under development.

## 12. Keywords

12.1 pavement; pavement markings; portable reflectometers; reflection

*ASTM International takes no position respecting the validity of any patent rights asserted in connection with any item mentioned in this standard. Users of this standard are expressly advised that determination of the validity of any such patent rights, and the risk of infringement of such rights, are entirely their own responsibility.*

*This standard is subject to revision at any time by the responsible technical committee and must be reviewed every five years and if not revised, either reapproved or withdrawn. Your comments are invited either for revision of this standard or for additional standards and should be addressed to ASTM International Headquarters. Your comments will receive careful consideration at a meeting of the responsible technical committee, which you may attend. If you feel that your comments have not received a fair hearing you should make your views known to the ASTM Committee on Standards, at the address shown below.*

*This standard is copyrighted by ASTM International, 100 Barr Harbor Drive, PO Box C700, West Conshohocken, PA 19428-2959, United States. Individual reprints (single or multiple copies) of this standard may be obtained by contacting ASTM at the above address or at 610-832-9585 (phone), 610-832-9555 (fax), or service@astm.org (e-mail); or through the ASTM website (www.astm.org).*