



Standard Test Method for Adhesion Between Steel Tire Cords and Rubber¹

This standard is issued under the fixed designation D 2229; the number immediately following the designation indicates the year of original adoption or, in the case of revision, the year of last revision. A number in parentheses indicates the year of last reapproval. A superscript epsilon (ϵ) indicates an editorial change since the last revision or reapproval.

1. Scope

1.1 This test method covers the determination of the force required to pull a steel cord from a block of vulcanized rubber.

1.2 Although designed primarily for steel cord, this test method may be applied with modifications to wire used in rubber products.

1.3 This test method can also be used for evaluating rubber compound performance with respect to adhesion to steel cord.

1.4 The values stated in SI units are to be regarded as the standard. No other units of measurement are included in this standard.

1.5 *This standard does not purport to address all of the safety concerns, if any, associated with its use. It is the responsibility of the user of this standard to establish appropriate safety and health practices and determine the applicability of regulatory limitations prior to use.*

2. Referenced Documents

2.1 ASTM Standards:

D 76 Specification for Tensile Testing Machines for Textiles²

D 123 Terminology Relating to Textiles²

D 1566 Terminology Relating to Rubber³

D 2904 Practice for Interlaboratory Testing of a Textile Test Method that Produces Normally Distributed Data²

E 105 Practice for Probability Sampling of Materials⁴

E 122 Practice for Choice of Sample Size to Estimate a Measure of Quality for a Lot or Process⁴

3. Terminology

3.1 Definitions

3.1.1 *adhesion, n*—in tire fabrics, the force required to separate a textile material from rubber or other elastomer by a definite prescribed method.

3.1.2 *rubber compound, n*—as used in the manufacture of rubber articles, an intimate mixture of elastomer(s) with all materials necessary for the finished article.

3.1.3 *steel cord, n*—a formed structure made of two or more steel filaments when used as an end product or a combination

¹ This test method is under the jurisdiction of ASTM Committee D-13 on Textiles and is the direct responsibility of Subcommittee D13.19 on Tire Cord and Fabrics. Current edition approved Nov. 10, 1999. Published January 2000. Originally published as D 2229–63 T. Last previous edition D 2229–98.

² Annual Book of ASTM Standards, Vol 07.01.

³ Annual Book of ASTM Standards, Vol 09.01.

⁴ Annual Book of ASTM Standards, Vol 14.02.

of strands or filaments and strands.

3.1.4 For definitions of other textile or rubber terms used in this test method refer to Terminology D 123 or Terminology D 1566.

4. Summary of Test Method

4.1 The steel cords are vulcanized into a block of rubber and the force necessary to pull the cords linearly out of the rubber is measured.

5. Significance and Use

5.1 This test method is considered satisfactory for the acceptance testing of commercial shipments of steel tire cord because current estimates of between-laboratory precision for single materials are considered acceptable and the method has been used extensively in the trade for acceptance testing.

5.1.1 If there are differences or practical significances between reported test results for two laboratories (or more), comparative tests should be performed to determine if there is a statistical bias between them, using competent statistical assistance. As a minimum, the test samples should be used that are as homogenous as possible, that are drawn from the material from which the disparate test results were obtained, and that are randomly assigned in equal numbers to each laboratory for testing. Other materials with established test values may be used for this purpose. The test results from the two laboratories should be compared using a statistical test for unpaired data, at a probability level chosen prior to the testing series. If a bias is found, either its cause must be found and corrected, or future test results must be adjusted in consideration of the known bias.

5.2 The mold described in this test method is primarily designed for quality acceptance testing for steel cord where the sample size for each cord is 4 or a multiple thereof, but any mold/cavity combination which will provide the required test block dimensions (Figs. 1 and 2) is acceptable.

5.3 Appendix X1 contains suggested ranges of environmental conditions for aging tests.

5.4 The property measured by this test method indicates whether the adhesion of the steel cord to the rubber is greater than the cohesion of the rubber, that is, complete rubber coverage of the steel cord, or less than the cohesion of the rubber, that is, lack of rubber coverage.

6. Apparatus

6.1 *Mold* (Figs. 2 and 3)—The mold is designed to produce

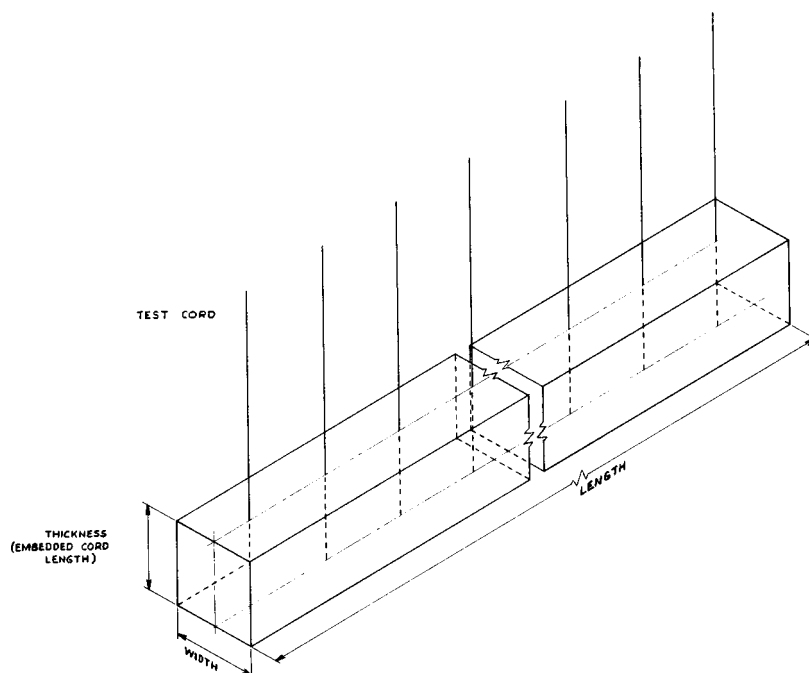

FIG. 1 Definition of Test Block Dimensions

four test blocks with the preferred dimensions, each containing 15 steel cords. The blocks are 200 mm long and 12.5 mm thick (embedded cord length). When testing cords equal to or less than 1.7-mm diameter, the mold in Fig. 2 and Fig. 3 should be used to produce blocks, and when testing cords with a diameter greater than 1.7 mm, the mold should be suitably modified. Molds designed to produce any other number of test blocks of the required dimensions are acceptable, and molds designed to produce blocks with different embedded cord length are permitted.

6.2 If more than one third of the cords break at the 12.5-mm embedment, it may be advisable to reduce the embedment by use of a suitable mold insert.

6.3 Testing Machine:

6.3.1 A constant-rate-of-extension (CRE) type tensile testing machine conforming to the requirements of Specification D 76 for textiles shall be used for measuring the pull-out force. The rate of travel of the power actuated grip shall be 50 mm/min. Other rates of travel up to 150 mm/min may be used as agreed upon by the purchaser and the supplier.

6.3.2 The top grip shall apply force to the cord during testing that is normal to the face of the test block.

6.3.3 The bottom grip (Fig. 4) shall be a special holder made for the vulcanized test block.

6.4 Press—A curing press, large enough to take the mold, and capable of a minimum pressure of 3.5 MPa over the total area of the mold plate. Electrical or steam heat for the top and bottom platens shall be provided, of sufficient capacity for maintaining the mold components at the temperatures required for the rubber compound being used.

6.5 Desiccator.

7. Materials and Reagents

7.1 Solvent—A solvent may be used to freshen the surface of the rubber when necessary, provided such solvent treatment

does not affect adhesion of the cord in the vulcanized block. A suitable solvent has been found to be a special lead-free gasoline (normal heptane), with a distillation range from 40 to 141°C and a maximum recovery of 97 %.

7.2 Rubber Compound—The rubber compound shall be furnished by the user of the cord, together with pertinent information of the temperature and time for the vulcanization of the particular rubber, as well as the conditioning period between vulcanization and testing. Because the performance of the rubber stock is affected by its age and storage conditions, the user of the cord shall also specify storage conditions and any time limits for storage of a particular rubber, or approve the storage conditions utilized by the producer. The rubber shall be provided in sheet form at least 215 mm wide and either 7 - 0, + 1 mm thick or 3.5 - 0, + 0.5 mm thick, sheeted onto nonhygroscopic backing, such as a plasticizer-free plastic material.

7.3 Mold Release Lubricant—A suitable mold release lubricant may be applied to the empty mold to facilitate test block removal. Excess lubricant shall be wiped from the mold and particularly from the slots provided for the cords. The lubricant should not be applied when exposed cord is in the area, and should only be used when absolutely necessary. Use of a mold release lubricant should be recorded on the test report.

NOTE 1—The use of mold release lubricant is not recommended. The mold should be permanently coated with Teflon® or preferably, with a stainless steel reinforced nonstick coating, such as Excalibur®.⁵

8. Hazards

8.1 Refer to the manufacturer's material safety data sheets (MSDS) for information on handling, use, storage, and disposal of chemicals used in this test.

⁵ Excalibur® is a registered trademark of the Whitford Corporation, West Chester, PA.

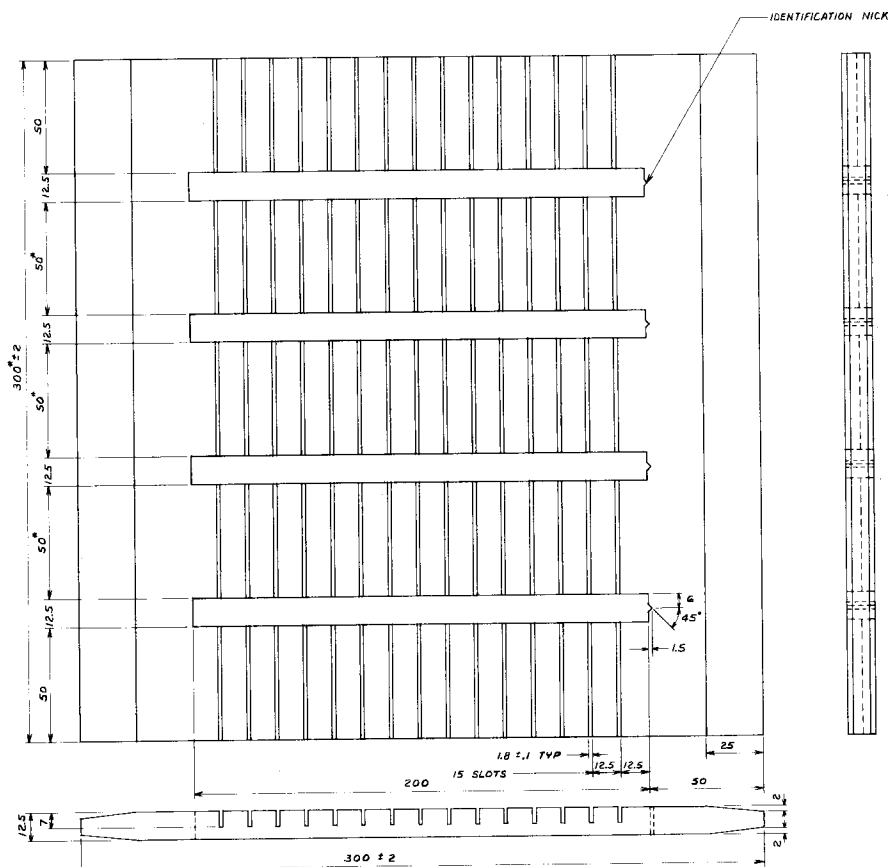

TOLERANCES
 All dimensions ± 0.2
 Angular $\pm 2^\circ$
 Except where noted

NOTE 1—All dimensions in millimetres except where noted.

NOTE 2—Material—Mild steel.

NOTE 3—Mold should be coated permanently with a polytetrafluoro-ethylene, such as Teflon®, or preferably, with a stainless steel reinforced polytetrafluoro-ethylene with a polyamid binder, such as Excalibur®.⁵

NOTE 4—Dimensions with “*” may be altered to accommodate test grips.

FIG. 2 Four-Cavity Steel Cord Adhesion Mold

8.2 Wear heat resistant gloves when working at the hot press and handling hot forms.

9. Sampling and Specimen Preparation

9.1 Obtain lot and laboratory samples in accordance with Practices E 105 and E 122.

9.2 Cut specimens from each laboratory sampling unit into lengths that are greater than the total mold length. To eliminate flare, use procedures in 9.2.1 or 9.2.2. Choose the number of specimen to achieve the desired level of test result precision. The relationship between the sample size and test precision is shown in Table 2.

9.2.1 Simultaneously cut and fuse the cut ends using a small portable welding device.

9.2.2 Tape the samples at the ends of the required specimen length and cut through the sample where it has been taped leaving the new ends of both sample and specimen taped.

9.3 Handle samples and specimens with care to prevent changes in surface conditions of the steel cord. Wear clean gloves when handling samples and specimens. If the tests

blocks cannot be constructed within 8 h store the cords in a desiccator at $23 \pm 2^\circ$.

10. Procedure

10.1 Test Block Construction:

10.1.1 Construct the test blocks in a cold mold or form having the same dimensions as the mold in the following manner.

10.1.2 Lay out specimens on a clean dry surface. Touch the specimens only at their ends. Steel cord is normally tested in the “as-received” condition; therefore, it is generally not cleaned nor dried prior to building the test block.

10.1.3 Cut pieces the rubber compound to the size of the mold cavity. If a thickness of 3.5 mm is supplied, it should be laminated to a 7 mm thickness before cutting to size. If the rubber surface appears dry or contaminated, it may be freshened with clean solvent described in 7.1 and allowed to dry at least 3 min. This will facilitate handling the test blocks prior to vulcanization.

10.2 Test Block Assembly:

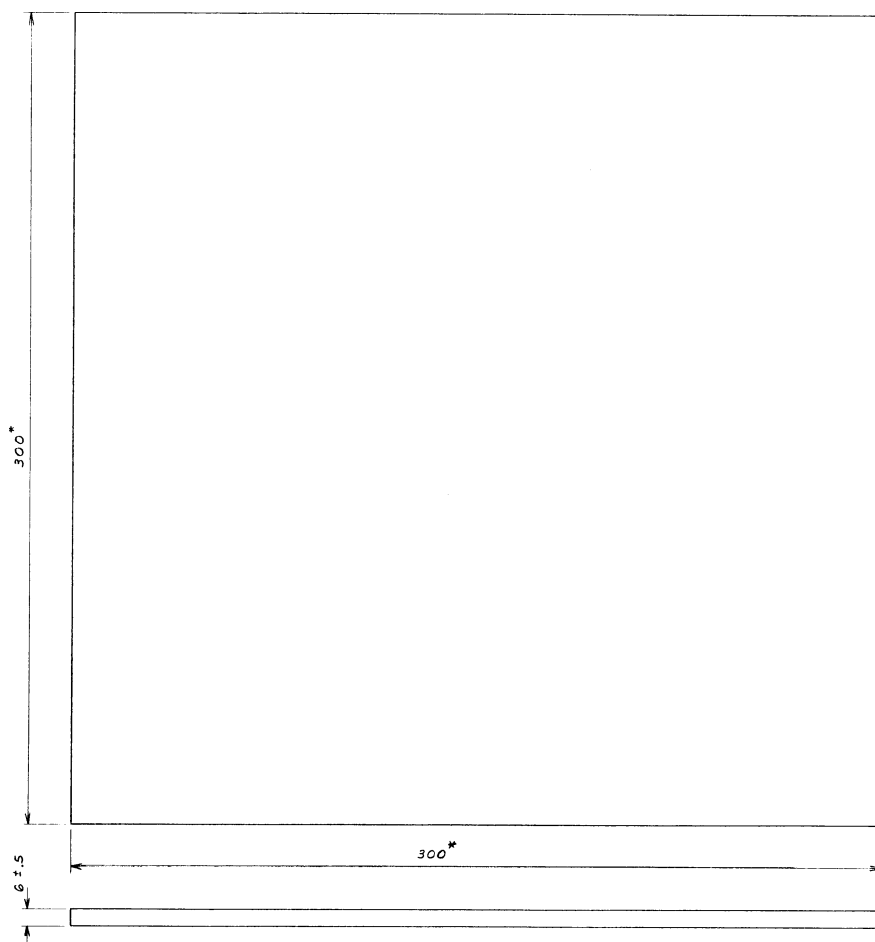

TOLERANCES

All dimensions ± 2
Except where noted

NOTE 1—Material—Mild steel.

NOTE 2—Number required—2.

NOTE 3—All dimensions in millimetres except where noted.

NOTE 4—Dimensions with "*" may be altered to accommodate the mold.

FIG. 3 Top and Bottom Plates for Adhesion Mold

10.2.1 Place one piece of rubber in each cavity with the protected side up and remove the protective film.

10.2.2 Place the specimen in individual slots with approximately equal lengths extending beyond either end of the form. Do not press the cords into the cavities with fingers. Make note of the location of the specimens for 10.2.4.

10.2.3 Remove the protective film from pieces of rubber compound and place one in each cavity with the freshly exposed surface against the cords. Press firmly in place using a wooden dowel or flat faced stitching tool.

10.2.4 Write the identification on each pad using a silver pen or marking pencil.

10.2.5 Carefully remove the four blocks from the form by pressing uniformly from the back side. Store at a temperature of $23 \pm 2^\circ\text{C}$ until vulcanization. Blocks should be vulcanized within a maximum of 12 h.

10.3 Vulcanizing:

10.3.1 Preheat the complete mold assembly to the required temperature.

10.3.2 Remove the mold assembly from the press and remove the top plate.

10.3.3 Place the preconstructed blocks in the mold. Take care to ensure that the blocks are seated in the mold cavities and all specimens are in the proper slots.

10.3.4 Place the top plate on the mold and place the mold assembly in the press. Close the press and apply a minimum pressure of 3.5 MPa on the mold surface.

10.3.5 At the end of the cycle, open the press remove the mold assembly. Remove the top and bottom plates, and push the blocks out with uniform pressure. Take care to minimize block deformation when removing from the mold.

10.4 Conditioning of Test Blocks:

10.4.1 Allow the blocks to rest at room temperature for a minimum of 16 h before testing.

10.4.2 Cut the blocks apart by clipping the cords flush with one side of each block. Trim any "flash" with a razor blade or suitable clippers, taking care not to damage the cord or cut into the body of the test block.

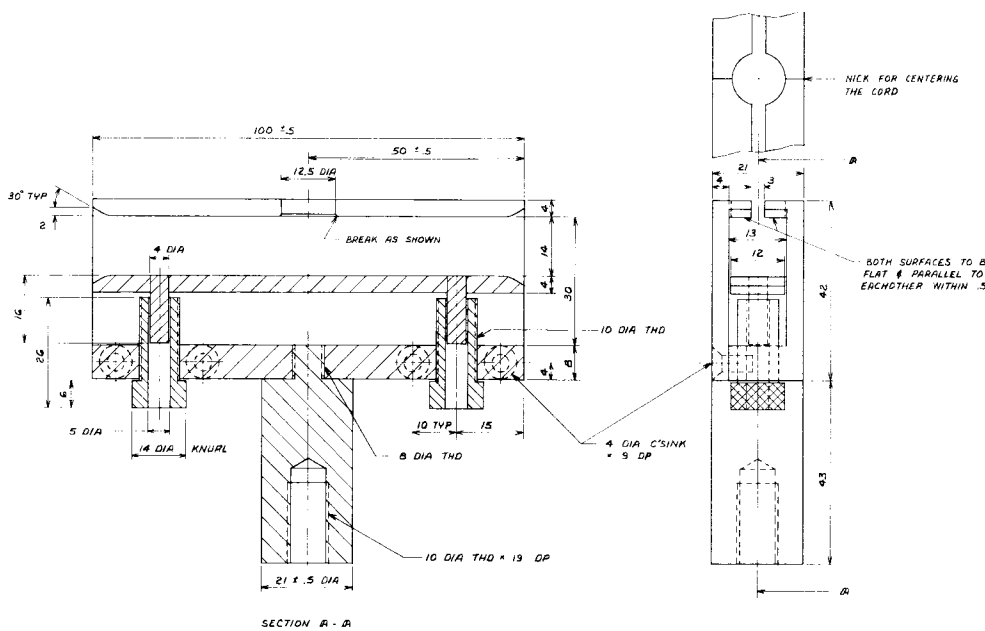

TOLERANCES

- All dimensions ±0.2
- Angular ±1/2°
- Except where noted

NOTE 1—Material—Steel.

NOTE 2—Break all sharp corners.

NOTE 3—All dimensions in millimetres except where noted.

FIG. 4 Bottom Grip

10.5 Testing:

10.5.1 Test at 24 ± 2°C unless otherwise agreed upon.

10.5.2 Push the block into the appropriate lower fixture and adjust the bottom plate of the fixture so that the block can be moved through the fixture but yet undergo minimum deformation during testing. Do not force the bottom plate against the test block.

10.5.3 Center each cord in succession in the 12.5-mm hole and clamp the cord in the upper grip.

10.5.4 Start the cross head.

10.5.5 Record, to the nearest 5 N, the maximum pull-out force required to extract the cord. Retain the specimens, properly identified, for visual evaluation if required.

10.5.6 Rate the rubber coverage of the pulled specimens visually from 1 to 5 or percent coverage using Table 1. The appearance can be evaluated with 0.5 point precision if using the 1 through 5 rating scale. Record visual ratings.

10.5.6.1 The precision and bias statement was developed using the percent rubber coverage system.

11. Calculation

11.1 Calculate the average pull-out force to the nearest 5 N using the values from the test blocks for each laboratory sampling unit and for the lot.

11.2 Calculate the average rubber coverage visual rating to the nearest 0.5 rating or percent using the values from the specimens pulled from the test blocks for each laboratory sampling unit and for the lot.

12. Report

12.1 State that the specimens were tested as directed in Test

TABLE 1 Critical Differences for Conditions Noted, 95 % Probability Level

Name of Property	Number of Observations	Single Operator Precision	Within-Laboratory Precision	Between-Laboratory Precision
Pull-out force, N		(Single-Material Comparisons)		
	4	49	52	85
	8	34	39	77
	16	24	31	74
		(Multi-Material Comparisons)		
	4	49	52	120
Rubber coverage, %	8	34	39	115
	16	24	31	112
		(Single-Material Comparisons)		
	4	7	7	19
	8	5	5	18
	16	4	4	18
	(Multi-Material Comparisons)			
4	11	11	28	
8	10	10	28	
16	9	9	28	

Method D 2229. Describe the material sampled and the method of sampling.

12.2 Report the following information:

12.2.1 Identification of rubber compounds.

12.2.2 Number of specimens per laboratory sampling unit and the number of laboratory sampling units per block.

12.2.3 Number of blocks per laboratory sampling unit where a laboratory sampling unit has been tested in more than one block.

12.2.4 The average pull-out force (newtons) for each laboratory sampling unit tested and the lot.

- 12.2.5 Date of test.
- 12.2.6 Rate of extension, if not standard.
- 12.2.7 Vulcanization time and temperature.
- 12.2.8 Visual evaluation, if required.
- 12.2.9 Any modifications to the test.

13.2.1 The steel tire cords used in the laboratory evaluation were of the following construction and nominal thickness:

Cord 1	1 × 2 + 7 × 0.22 mm	0.81 mm
Cord 2	(1 × 3 × 0.20 mm) + 6 × 0.35 mm	1.13 mm

The details of the formulation of the rubber compounds are contained in a research report.⁶

13.3 *Precision*—Two test results should be considered significantly different at the 95 % probability level if the difference equals or exceeds the critical differences listed in Table 2. For the purposes of the interlaboratory evaluation, each combination of steel tire cord and rubber compound was considered as a different material; therefore, caution should be exercised when referring to the critical differences for multi-material comparisons.

13.4 *Bias*—The procedures in this test method produce test values that can be defined only in terms of a test method. There is no independent referee method by which bias may be determined. This test method has no known bias.

NOTE 2—The tabulated values of the critical differences should be considered to be a general statement, particularly with respect to between-laboratory precision. Before a meaningful statement can be made about two specific laboratories, the amount of statistical bias, if any, between them must be established, with each comparison being based on recent data obtained on specimens taken from a lot of material of the type being evaluated so as to be as nearly homogeneous as possible and then randomly assigned in equal numbers to each of the laboratories (see 5.1.1).

14. Keywords

14.1 adhesion; rubber; steel; tire cord

⁶ Supporting data is available from ASTM Headquarters. Request RR: D13-1054.

APPENDIX

(Nonmandatory Information)

X1. SUGGESTED RANGES OF CONDITIONS FOR ACCELERATED AGING OF STEEL CORD ADHESION BLOCKS

TABLE X1.1 Ranges of Conditions for Accelerated Aging of Steel Cord Adhesion Blocks

Uncured humidity	90–95 % RH, 35–40°C
Cured humidity	90–95 % RH, 35–40°C or 95–100 % RH, 70–80°C
Oxygen	70–80°C
Steam	120–130°C
Thermal	100–120°C

**NOTICE: This standard has either been superseded and replaced by a new version or discontinued.
Contact ASTM International (www.astm.org) for the latest information.**



The American Society for Testing and Materials takes no position respecting the validity of any patent rights asserted in connection with any item mentioned in this standard. Users of this standard are expressly advised that determination of the validity of any such patent rights, and the risk of infringement of such rights, are entirely their own responsibility.

This standard is subject to revision at any time by the responsible technical committee and must be reviewed every five years and if not revised, either reapproved or withdrawn. Your comments are invited either for revision of this standard or for additional standards and should be addressed to ASTM Headquarters. Your comments will receive careful consideration at a meeting of the responsible technical committee, which you may attend. If you feel that your comments have not received a fair hearing you should make your views known to the ASTM Committee on Standards, at the address shown below.

This standard is copyrighted by ASTM, 100 Barr Harbor Drive, PO Box C700, West Conshohocken, PA 19428-2959, United States. Individual reprints (single or multiple copies) of this standard may be obtained by contacting ASTM at the above address or at 610-832-9585 (phone), 610-832-9555 (fax), or service@astm.org (e-mail); or through the ASTM website (www.astm.org).