



Designation: **D 3108 – 9501**

## Standard Test Method for Coefficient of Friction, Yarn to Solid Material<sup>1</sup>

This standard is issued under the fixed designation D 3108; the number immediately following the designation indicates the year of original adoption or, in the case of revision, the year of last revision. A number in parentheses indicates the year of last reapproval. A superscript epsilon ( $\epsilon$ ) indicates an editorial change since the last revision or reapproval.

### 1. Scope

1.1 This test method covers the measurement of the kinetic frictional properties of a moving yarn in contact with a solid material.

NOTE 1—For determining yarn-to-yarn friction, refer to Test Method D 3412.

1.2 This test method specifies a relative speed of 100 m/min. The test method may be used at other speeds, although with a possible change in precision and coefficient of friction.

1.3 This test method covers the measurement of the coefficient of kinetic friction between yarn and solid surface or surfaces of constant radius in the contact area. If a yarn of uniform value is used, comparisons of frictional properties of different solid materials can be made with relation to that yarn. If a given solid material is used, comparisons of frictional properties of different yarns, or yarns with different finishes, can be made with relation to that particular solid material.

1.4 This test method specifically recommends wrap angles of 3.14 and 6.28 radian (180 and 360°), but other wrap angles may be used, again with a possible change in precision and level. The angle of wrap should not be so great, especially for yarns having high coefficients of friction, that it causes the output tension to exceed the yield value for the yarn being tested. Also, in every case the angle of wrap should not be less than 1.57 rad (90°).

1.5 This test method has been applied to yarns having linear densities ranging between 10 and 80 tex (90 and 720 denier) and having coefficients of friction ranging between 0.1 and 0.5 but may also be used with yarns outside these ranges of linear densities and coefficients of friction.

1.6 The values stated in SI units are to be regarded as the standard. The values given in parentheses are for information only.

1.7 *This standard does not purport to address all of the safety concerns, if any, associated with its use. It is the responsibility of the user of this standard to establish appropriate safety and health practices and determine the applicability of regulatory limitations prior to use.* Specific precautionary statements are given in Section 7.

### 2. Referenced Documents

2.1 *ASTM Standards:*

<sup>1</sup> This test method is under the jurisdiction of ASTM Committee D-13 on Textiles and is the direct responsibility of Subcommittee D13.58 on Yarn and Fiber Test Methods, General Methods.

Current edition approved ~~May 15, 1995~~; September 10, 2001. Published ~~July 1995~~; November 2001. Originally published as D3108 – 72T. Last previous edition D3108 – 895.

D 123 Terminology Relating to Textiles<sup>2</sup>

D 1776 Practice for Conditioning Textiles for and Testing Textiles<sup>2</sup>

D 1907 Test Method for Linear Density of Yarn (Yarn Number) by the Skein Method<sup>2</sup>

D 2258 Practice for Sampling Yarn for Testing<sup>2</sup>

D 3412 Test Method for Coefficient of Friction, Yarn to Yarn<sup>3</sup>

### 3. Terminology

#### 3.1 Definitions:

3.1.1 *coefficient of friction, n*—the ratio of the tangential force that is needed to maintain uniform relative motion between two contacting surfaces to the perpendicular force holding them in contact.

3.1.2 *friction, n*—the resistance to the relative motion of one body sliding, rolling, or flowing over another body with which it is in contact.

3.1.2.1 *Discussion*—There are two frictional properties exhibited between any pair of surfaces: static friction and kinetic friction. Test Methods D 3108 and D 3412 both measure the coefficient of friction for kinetic friction.

3.1.3 *kinetic friction, n*—friction developed between two bodies in motion. (Compare *Static friction*.)

3.1.4 *radian, n*—the plane angle between two radii of a circle which intersects the circumference of the circle making an arc equal in length to the radius.

3.1.4.1 *Discussion*—A radian is equal to  $180^\circ$  divided by  $\Pi$  and is approximately  $57.3^\circ$ .

3.1.5 *static friction, n*—friction developed between two touching bodies at the time one body starts to move relative to another. (Compare *Kinetic friction*.)

3.1.6 *wrap angle, n*—in yarn friction testing, the cumulative angular contact of the test specimen against the friction-inducing device, expressed in radians.

3.1.7 For definitions of other textile terms used in this test method, refer to Terminology D 123.

### 4. Summary of Test Method

4.1 A length of yarn is run at known speeds and in contact with either single or multiple friction surfaces using a specified wrap angle. (See Fig. 1.) The yarn input and output tensions are measured, and the coefficient of friction is calculated by means of Amontons' law (see 11.4). Alternatively, apparatus is used in which the ratio of output tension to input tension is measured allowing the coefficient of friction to be indicated directly.

### 5. Significance and Use

5.1 Test Method D 3108 for the determination of kinetic friction between yarn and solid materials may be used for the acceptance testing of commercial shipments of yarn, but caution is advised since between laboratory precision is known to be poor. Comparative tests as directed in 5.1.1 may be advisable.

<sup>2</sup> Annual Book of ASTM Standards, Vol 07.01.

<sup>3</sup> Annual Book of ASTM Standards, Vol 07.02.

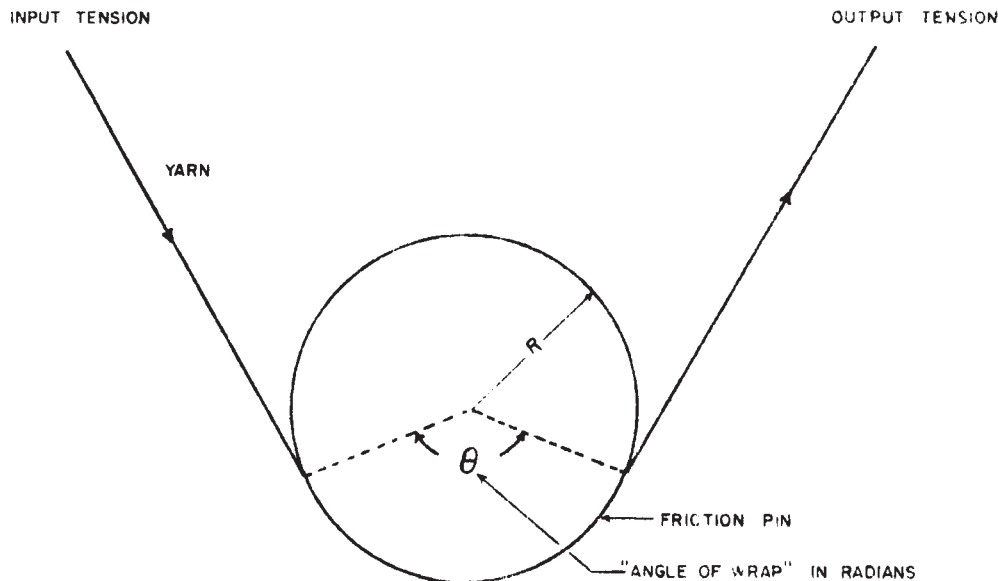

FIG. 1 Schematic Diagram of Angle of Wrap

5.1.1 In case of a dispute arising from

5.1.1 If there are differences or practical significance between reported test results when using Test Method D 3108 for acceptance testing of commercial shipments, the purchaser and the supplier should conduct two laboratories (or more), comparative tests should be performed to determine if there is a statistical bias between their laboratories. Competent them, using competent statistical assistance is recommended for the investigation of bias. assistance. As a minimum, the two parties should take a group of test specimens which samples that are as homogeneous as possible and which are possible, drawn from a lot of the material of from which the type in question. The disparate test specimens should then be results were obtained, and randomly assigned in equal numbers to each laboratory for testing. The average test results from the two laboratories should be compared using Student's *t*-test a statistical test for unpaired data and an acceptable data, at a probability level chosen by prior to the two parties before the testing is begun. series. If a bias is found, either its cause must be found and corrected, or the purchaser and the supplier must agree to interpret future test results with for that material must be adjusted in consideration to of the known bias.

5.2 The frictional properties of textile yarns and of machinery components such as yarn guides are of general interest and have many applications. Because the frictional properties of yarns will affect the performance and life of yarn guides, sewing and knitting needles, and other contact surfaces, the modifying effects of surface finishes and lubricants are of special interest. Frictional properties also affect the quality and performance properties of yarns and subsequently of products made from them. As a consequence, frictional properties are of interest in research, control, and product design.

5.3 It is stressed that there is no coefficient of friction for a single body such as a yarn or a surface. A coefficient of friction measures the interaction between two bodies or elements such as a yarn running over a surface.

5.4 Although this method lays down standardized conditions of test, nonstandard conditions may be used for research or diagnosis but should be reported as such.

5.5 This method covers determination of the mean friction over a specified length of yarn.

5.6 Additional information has been reported in the literature.<sup>4,5,6</sup>

**6. Apparatus**

6.1 *Friction Testing Apparatus (Indirect)*<sup>7</sup> (Fig. 2)—Apparatus in which the input tension is measured or controlled to a set value, the output tension is measured, and the coefficient of friction is calculated within or outside the apparatus.

6.1.1 *Yarn Tension Input Control*—A means of controlling the yarn input tension to the nearest  $\pm 1$  mN ( $\pm 0.1$  gf). A demand-fed apparatus with a fixed weight is suitable.

6.1.2 *Yarn Input Tension Measurement*—The yarn input tension is measured to within  $\pm 1$  mN ( $\pm 0.1$  gf) using a suitable tension gage producing an electrical signal. The signal is recorded as mN (gf) or is used in combination with the yarn output tension measurement to calculate the coefficient of friction.

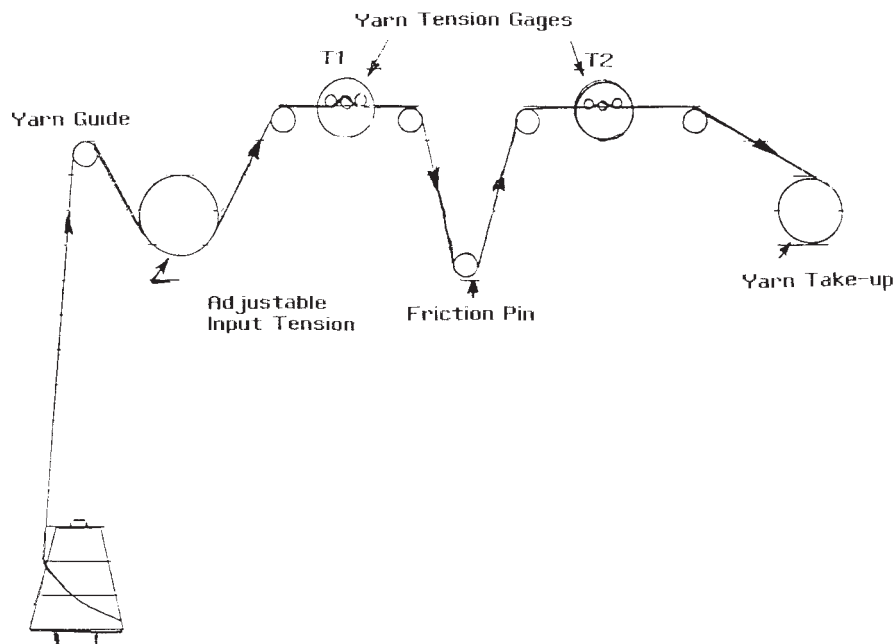

FIG. 2 Schematic Diagram of Typical Yarn Friction Measuring Apparatus, Indirect Type

<sup>4</sup> Olsen, J.S., "Frictional Behaviour of Textile Yarns," *Textile Research Journal*, Vol 39 No 1, 1969, pp 31-37.

<sup>5</sup> Lyne, D.G., "Dynamic Friction Between Cellulose Acetate Yarn and a Metal Cylinder," *Journal of the Textile Institute*, Vol 46, 1955, p 112.

<sup>6</sup> Rubenstein, C., "Review of the Factors Influencing the Friction of Fibres, Yarns and Fabrics," *Wear* Vol 2, 1958-59, p 296.

<sup>7</sup> Equipment meeting these requirements may be commercially obtained from Lawson Hemphill (Sales) Inc., PO Drawer 6388, Spartanburg, SC 29304.

6.1.3 *Yarn Output Tension Measurement*—The yarn output tension is measured to within  $\pm 1$  mN ( $\pm 0.1$  gf) using a suitable tension gage producing an electrical signal. The signal is recorded as mN (gf) or is used in combination with the yarn input tension measurement to calculate the coefficient of friction. A suitable chart recorder may be used.

6.2 *Friction Testing Apparatus (Direct)* (Fig. 3)—Apparatus in which the ratio of output to input tensions is established directly and the coefficient of friction indicated on a scale or display. The comparison may be mechanical.

6.2.1 *Yarn Tension Input Control*—Since this type of apparatus automatically derives the ratio of output-to-input-tension, close control of input tension is not usually required. However, because the absolute level of input tension can affect the measured coefficient of friction for certain yarns, particularly low-twist yarns, the general level of input tension should be preset, for example with a dead weight disk tensioner.

6.2.2 *Coefficient of Friction Indicator*—The nature of this will depend on the instrument being used. Typically, a pointer or a chart recorder pen is displaced by the movement of the components that bring the system into balance and the product of the input tension and the distance from the axis equals the product of the output tension and the distance from the axis (see Fig. 3).

6.3 *Friction Surface*, may be changeable on some equipment.

6.3.1 *Standard Friction Surface*—Friction surfaces having a diameter of 0.5 in. (12.7 mm) and a chrome surface of 4 to 6  $\mu$ m roughness. The use of one, two, or three pins in sequence has been found satisfactory although there may be a difference in the results (theoretically only the total angle of wrap and not the number of pins should affect the results). (See 12.3.4).

6.3.2 *Other Friction Surfaces*—Unless the apparatus has a friction surface that cannot be altered, friction surfaces of different materials, sizes, and surface finish may be used but must be specified in the report (see section 11.3.4–12.3.4).

6.4 *Drive System*, consisting of a controlled speed yarn transporting device with appropriate controls to record and adjust the linear or throughput speed. Generally, a speed of less than 300 m/min has been found preferable. The yarn transporting device should be constructed to eliminate yarn slippage by the use of high-friction surface.

6.5 *Cotton Yarn For Cleaning*—A thoroughly scoured cotton yarn that is highly absorbent (see section 10.2.2 and Annex A1).

6.6 *Solvent*—See 9 10.2.

## 7. Hazard

7.1 Refer to the manufacturer’s material safety data sheet for information on storage, handling, use, and disposal of chemicals used in this test method.

## 8. Sampling

8.1 *Lot Sample*—As a lot sample for acceptance testing, take at random the number of shipping units directed in an applicable material specification or other agreement between the purchaser and the supplier, such as an agreement to use Practice D 2258. Consider shipping cases or other shipping units to be the primary sampling units.

NOTE 2—An adequate specification or other agreement between the purchaser and the supplier requires taking into account the variability between shipping units, between packages or ends within a shipping unit, and between specimens from a single package so as to provide a sampling plan with a meaningful producer’s risk, consumer’s risk, acceptable quality level, and limiting quality level.

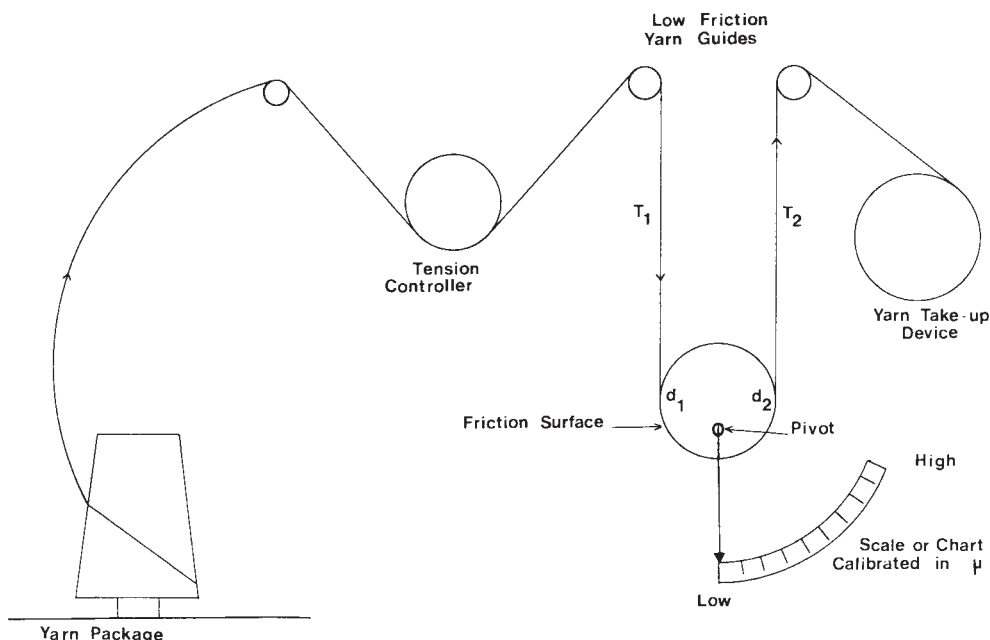

FIG. 3 Schematic Diagram of Typical Yarn Friction Measuring Apparatus, Direct Type

8.2 *Laboratory Sample*—As a laboratory sample for acceptance testing, take at random from the each shipping unit in the lot sample the number of packages or ends directed in an applicable material specification or other agreement between the purchaser and the supplier such as an agreement to use Practice D 2258. Preferably, the same number of packages should be taken from each shipping unit in the lot sample. If differing numbers of packages are to be taken from shipping units in the lot sample, determine at random which shipping units are to have each number of packages drawn.

8.3 *Test Specimens*—Test one specimen from each package in the laboratory sample.

## 9. Conditioning

9.1 *Preparation of Test Packages*—Remove sufficient yarn from the test packages to avoid testing nonrepresentative layers. If in doubt, remove about 10 % of the length of yarn on the package.

9.2 The strand to be tested must have a uniform moisture content along its length. Atmospheric conditions must therefore be stable and the strand must be in equilibrium with the prevailing atmosphere. To satisfy this condition, testing should be carried out after thorough conditioning in the standard atmosphere for testing textiles.

9.3 *Preconditioning*—Precondition packages of yarn for at least 3 h in an atmosphere with a relative humidity between 5 and 25 % and a temperature not exceeding 50°C (120°F).

9.4 *Conditioning*—Condition the preconditioned packages of yarn in the standard atmosphere for testing textiles (relative humidity  $65 \pm 2$  % and temperature  $21 \pm 1^\circ\text{C}$  ( $70 \pm 2^\circ\text{F}$ )) in moving air until it has reached moisture equilibrium for testing as directed in Practice D 1776.

## 10. Procedure

10.1 Test all specimens in the standard atmosphere for testing textiles which is  $21 \pm 1^\circ\text{C}$  ( $70 \pm 2^\circ\text{F}$ ) and  $65 \pm 2$  % relative humidity.

10.2 Prior to each test, thoroughly clean the friction elements, input rolls, and any other surfaces with which the yarn comes in contact up to and including the friction element, using one of the following:

10.2.1 A solvent which contains no trace oils, or

NOTE 3—**Precaution:** If solvent is used, appropriate health and safety precautions must be taken. (See Section on Hazards)

10.2.2 A thoroughly scoured cotton yarn<sup>8</sup> that is highly absorbent used as a cleaning yarn. See Annex A1 for details.

10.3 Check the surface properties of the friction elements for wear, gouging, or channeling. Some textile yarns, specifically glass, stainless steel, delustered yarns, and other high-modulus yarns, are known to create excessive wear on most guide surface materials, including chromium. Check for evidence of surface wear periodically by the use of control yarns, microscopic examination, or other forms of examining or measuring surface uniformity. Replace or refurbish friction elements which show signs of wear, gouging, or channeling.

10.4 Take care not to contaminate the yarn test specimen or the cleaned yarn-contacting surfaces of the apparatus.

10.5 Feed the yarn through the apparatus. Use identical pin locations, friction surfaces, and input tensions for all tests to be compared directly.

10.5.1 If the apparatus requires the input tension to be standardized, adjust it to  $9.8 \pm 1$  mN/tex (0.1 gf/den).

NOTE 4—When yarns heavier than 80 tex (720 den) are being tested, an input tension of less than 9.8 mN/tex (0.1 gf/den) may have to be used. Report any such change with the test results.

10.5.2 If the yarn linear density (tex or denier) is not known, determine this property as directed in Test Method D 1907, Option 1. It is important that the linear tex (denier) of the yarn be determined accurately as the proper input tension in terms of millinewtons per tex or grams-force per denier is required for accurate results.

10.6 Check the equipment by running yarns through the apparatus without contacting friction pins to ensure that the input tension is identical to the output tension.

10.7 Align the yarn over the contact surface and carefully adjust the angle of contact of the specimen with the pin or pins to the required angle. In the absence of any applicable specification or agreement, use a wrap angle of 3.14 radian ( $180^\circ$ ) or 6.28 radian ( $360^\circ$ ).

NOTE 5—The actual wrap angle achieved with any given diameter of friction surface is a function of the geometry of the instrument. On some instruments this geometry can be altered to maintain a specific wrap angle. On instruments where this is not possible, the wrap angle can be calculated from the diameter of the friction surface, the distance at which it is located from the yarn guides nearest to the friction surface and their distance apart. This wrap angle can then be used in Eqs (3) or (4) or in instruments of the direct reading type, a correction can be applied to the indicated coefficient of friction.

10.8 Set the yarn speed to 100 m/min (110 yd/min) unless applicable specifications or agreement states otherwise.

10.9 Start the apparatus. Note or record the results after any initial surges have been passed.

## 11. Calculation

11.1 *Friction Test Apparatus, Indirect:*

<sup>8</sup> Yarn meeting this requirement may be commercially obtained from Lawson-Hemphill (Sales) Inc: PO Drawer 6388, Spartanburg, SC 29304.

11.2 Unless the apparatus calculates average tension, determine the average output tension by laying a transparent plastic straightedge, with a center reference line, over the strip chart. Move the transparent straightedge parallel with the abscissa (time scale) until half the peaks appear above and half below the reference line. The average output tension should include only random variation and should not be influenced by abnormal periodicities such as initial surges in tension.

11.3 *Friction Test Apparatus, Direct and Indirect:*

11.4 Unless the apparatus records the coefficient of friction directly (6.2), calculate the average coefficient of friction for each specimen to the nearest 0.01 using Eq 1 or Eq 2:

$$\text{Exp } (\mu\theta) = T_2/T_1 \quad (1)$$

$$\mu = (\ln T_2 - \ln T_1)/\theta = \ln(T_2/T_1)/\theta \quad (2)$$

where:

$\mu$  = coefficient of friction,

$\ln$  = natural logarithm or logarithm to the base  $e$ , where  $e = 2.71828$ . . . ,  $\text{Exp } (x)$  = an expression meaning  $e^x$ ,

$T_1$  = average input tension, mN or gf,

$T_2$  = average output tension, mN or gf, and

$\theta$  = cumulative wrap angle, radians.

11.5 Calculate the average coefficient of friction for the laboratory and lot sample.

11.6 Calculate the standard deviation or coefficient of variation or both for package to package variation, if requested.

11.7 Calculate the magnitude, frequency, and cyclic behavior of abnormal periodicities, when required.

NOTE 6—The interpretation of abnormal periodicities is a function of the response time of the recording system.

## 12. Report

12.1 State that the specimens were tested as directed in Test Method D 3108. Describe the material or product sampled and the method of sampling used.

12.2 Report the following information:

12.2.1 Average coefficient of friction of the laboratory sample and each lot sample.

12.2.2 Magnitude, frequency, and cyclic behavior of abnormal periodicities, if present.

12.3 Testing conditions including:

12.3.1 Apparatus used;

12.3.2 Test speed;

12.3.3 Length of yarn measured;

12.3.4 Size, number, and type of friction surface;

12.3.5 Wrap angle (cumulative, if more than one friction surface);

12.3.6 Yarn linear density in tex; and

12.3.7 Yarn input tension (mN or gf) if it differs from the level specified in 10.5.1.

## 13. Precision and Bias

13.1 *Interlaboratory Test Data*<sup>9</sup>—A statistically designed test program was carried out in 1968 by four laboratories, each testing three yarn samples at two rates of speed. Two sets of independent measurements were made by each laboratory. The yarn samples were transferred from laboratory to laboratory and all measurements were made on yarn from the same package. The components of variances expressed as coefficients of variation were calculated to be:

*Single Operator Component*—3.25 % of the average,

*Between-Laboratory Component*—7.90 % of the average.

NOTE 7—Although interlaboratory trials using apparatus of the direct reading type have not been reported, their use in industry suggests that there is no major effect upon the variability of observations when using apparatus of this type.

13.2 *Precision*—For the components of variance reported in 13.1, two averages of observed values should be considered significantly different at the 95 % probability level if the difference equals or exceeds the critical differences listed in Table 1.

NOTE 8—The information in 13.2 is a general statement particularly with respect to between laboratory precision. Before a meaningful statement can be made about two specific laboratories the amount of statistical bias, if any, between them must be established with each comparison being based on recent data obtained on randomized specimens from one sample of the material to be tested.

13.3 *Bias*—The ~~true~~ coefficient of friction can be defined only in terms of a specific test method. Within this limitation, Test Method D 3108 has no known bias.

## 14. Keywords

14.1 coefficient of friction; yarn

<sup>9</sup> Supporting data from the interlaboratory tests are available from ASTM Headquarters. Request RR:D13-1000.



**TABLE 1 Critical Differences for Determining Precision**

Number of Observations in Each Average	Critical Differences, Percent of Grand Average, Under Conditions of <sup>A,B</sup>	
	Single Operator Precision	Between Laboratory Precision
1	9.0	23.6
2	6.3	23.0
3	5.2	22.4
5	4.0	22.3
10	2.8	22.1

<sup>A</sup>The critical differences were calculated using  $t = 1.960$  which is based on infinite degrees of freedom.

<sup>B</sup>To convert the values of the critical differences to units of measure, multiply the critical difference by the average of the two specific sets of data being compared and then divide by 100.

## ANNEX

### (Mandatory Information)

#### A1. PREPARATION OF CLEANING YARN FOR FRICTION TESTING APPARATUS<sup>10</sup>

A1.1 Cleaning yarn is a thoroughly scoured cotton yarn that is highly absorbent. Since cleaning yarn must be strong enough to withstand the high tension imposed upon it during the cleaning of friction testing apparatus, it is typically a 2-ply to 5-ply cotton yarn of 50 to 100 tex (12 to 6 cc).

A1.2 The yarn should be handled as little as possible and gloves should be worn to protect yarn against contamination.

A1.3 Prepare the yarn in hank form as follows:

A1.3.1 Sour and rinse thoroughly.

NOTE A1.1—The term “sour” is used in textile finishing to describe treatment with dilute acid. Hydrochloric acid at a concentration of 1 L8N hydrochloric acid to 225 L water is frequently preferred since this not only neutralizes alkali but also removes metal ions which could affect strength after scouring.

A1.3.2 Scour for 3 h at 275 kPa (40 psi) pressure, using 1 % caustic soda and 0.3 % castor oil soap; rinse thoroughly.

A1.3.3 Intermediate sour and rinse thoroughly.

A1.3.4 Scour for 3 h at 275 kPa (40 psi) pressure, using 1 % caustic soda; rinse.

A1.3.5 Scour; rinse, and dry thoroughly.

A1.3.6 Then carefully rewind the yarn on to packages. Use a thoroughly cleaned winding machine and handle the yarn as little as possible. Protectively wrap the completed packages.

NOTE A1.2—**Precaution:** Refer to the manufacturer’s material safety data sheet for information on storage, handling, use and disposal of chemicals used in this test method.

<sup>10</sup> Based on *Methods of Test for Textiles Handbook II*, 1974, British Standards Institute, Maylands Avenue, Hemel Hempstead, Herts, HP2 4SQ, England.

*ASTM International takes no position respecting the validity of any patent rights asserted in connection with any item mentioned in this standard. Users of this standard are expressly advised that determination of the validity of any such patent rights, and the risk of infringement of such rights, are entirely their own responsibility.*

*This standard is subject to revision at any time by the responsible technical committee and must be reviewed every five years and if not revised, either reapproved or withdrawn. Your comments are invited either for revision of this standard or for additional standards and should be addressed to ASTM International Headquarters. Your comments will receive careful consideration at a meeting of the responsible technical committee, which you may attend. If you feel that your comments have not received a fair hearing you should make your views known to the ASTM Committee on Standards, at the address shown below.*

*This standard is copyrighted by ASTM International, 100 Barr Harbor Drive, PO Box C700, West Conshohocken, PA 19428-2959, United States. Individual reprints (single or multiple copies) of this standard may be obtained by contacting ASTM at the above address or at 610-832-9585 (phone), 610-832-9555 (fax), or service@astm.org (e-mail); or through the ASTM website (www.astm.org).*