



Designation: D 3512 – 99a02

## Standard Test Method for Pilling Resistance and Other Related Surface Changes of Textile Fabrics: Random Tumble Pilling Tester<sup>1</sup>

This standard is issued under the fixed designation D 3512; the number immediately following the designation indicates the year of original adoption or, in the case of revision, the year of last revision. A number in parentheses indicates the year of last reapproval. A superscript epsilon ( $\epsilon$ ) indicates an editorial change since the last revision or reapproval.

### 1. Scope

1.1 This test method covers the resistance to the formation of pills and other related surface changes on textile fabrics using the random tumble pilling tester. The procedure is generally applicable to all types of woven and knitted apparel fabrics.

NOTE 1—For other test methods for the pilling resistance of textiles, refer to Test Methods D 3511, D 3514, and D 4970.

1.2 Some fabrics that have been treated with a silicone resin may not be satisfactorily tested by this procedure because the silicone resin may transfer onto the cork liners in the test chamber and cause erroneous results.

1.3 The values stated in either SI units or inch-pound units are to be regarded separately as the standard. Within the text, the inch-pound units are to be regarded as the standard. Within the text, the inch-pound units are shown in parentheses. The values stated in each system are not exact equivalents; therefore, each system shall be used independently of the other. Combining values from the two systems may result in nonconformance with the specification.

1.4 *This standard does not purport to address all of the safety concerns, if any, associated with its use. It is the responsibility of the user of this standard to establish appropriate safety and health practices and determine the applicability of regulatory limitations prior to use.*

### 2. Referenced Documents

2.1 *ASTM Standards:*

---

<sup>1</sup> This test method is under the jurisdiction of ASTM Committee D-13 on Textiles and is the direct responsibility of Subcommittee D13.60 on Fabric Test Methods. Specific Current edition approved ~~Sept. 10, 1999~~; April 10, 2002. Published ~~December 1999~~; July 2002. Originally published as D 3512 – 76. Last previous edition D 3512 – 99a.

D 123 Terminology Relating to Textiles<sup>2</sup>

D 1776 Practice for Conditioning and Testing Textiles<sup>2</sup>

D 3511 Test Method for Pilling Resistance and Other Related Surface Changes of Textile Fabrics: Brush Pilling Tester<sup>3</sup>

D 3514 Test Method for Pilling Resistance and Other Related Surface Changes of Textile Fabrics: Elastomeric Pad<sup>3</sup>

D 4970 Test Method for Pilling Resistance and Other Related Surface Changes of Textile Fabrics (Martindale Pressure Tester Method)<sup>3</sup>

F 104 Classification System for Nonmetallic Gasket Materials<sup>4</sup>

2.2 *ASTM Adjuncts:*

12-435120-00 Set of 5 Photographic Standards for Random Tumble Pilling Test<sup>5</sup>

### 3. Terminology

3.1 *Definitions:*

3.1.1 *fuzz, n*—untangled fiber ends that protrude from the surface of a yarn or fabric.

3.1.2 *pilling resistance, n*—resistance to the formation of pills on the surface of a textile fabric.

3.1.3 *pills, n*—bunches or balls of tangled fibers which are held to the surface of a fabric by one or more fibers.

3.1.4 For definitions of other textile terms used in this test method, refer to Terminology D 123.

### 4. Summary of Test Method

4.1 Pilling and other changes in surface appearance, such as fuzzing, that occur in normal wear are simulated on a laboratory testing machine. Pills are caused to form on fabric by a random rubbing action produced by tumbling specimens in a cylindrical test chamber lined with a mildly abrasive material. To form pills with appearance and structure that resemble those produced in actual wear, small amounts of short-length gray cotton fiber are added to each test chamber with the specimens. The degree of fabric pilling is evaluated by comparison of the tested specimens with visual standards that may be actual fabrics, or photographs of fabrics, showing a range of pilling resistance. The observed resistance to pilling is reported using an arbitrary rating scale.

### 5. Significance and Use

5.1 *Acceptance Testing*—This test method of fabrics for resistance to pilling is not recommended for acceptance testing. If it is used for acceptance testing, it should be used with caution because the between-laboratory precision is poor. In some cases the purchaser and the supplier may have to test a commercial shipment of one or more specific materials by the best available test method, even though the test method is not recommended for acceptance testing.

5.1.1 If there are differences or practical significance between reported test results for two laboratories (or more), comparative tests should be performed to determine if there is a statistical bias between them, using competent statistical assistance. As a minimum, the test samples should be used that are as homogeneous as possible, drawn from the material from which the disparate test results were obtained, and randomly assigned in equal numbers to each laboratory for testing. Other materials with established test values may be used for this purpose. The test results from the two laboratories should be compared using a statistical test for unpaired data, at a probability level chosen prior to the testing series. If a bias is found, either its cause must be found and corrected, or future test results must be adjusted in consideration of the known bias.

5.2 The pilling of textile fabrics is a very complex property because it is affected by many factors which may include type of fiber or blends, fiber dimensions, yarn and fabric construction, fabric finishing treatments and refurbishing method. Testing before refurbishing may be advisable. The pilling resistance of a specific fabric in actual wear varies more with general conditions of use and individual wearers than in replicate fabric specimens subjected to controlled laboratory tests. This experience should be borne in mind when adopting levels of acceptability for any series of standards.

5.3 Pills vary appreciably in size and appearance and depend on the presence of lint and degree of color contrast. These factors are not evaluated when pilling is rated solely on the number of pills. The development of pills may be accompanied by other surface phenomena such as loss of cover, color change, or the development of fuzz. Since the overall acceptability of a specific fabric is dependent on both the characteristics of the pills and the other factors affecting surface appearance, it is suggested that fabrics tested in the laboratory be evaluated subjectively with regard to their acceptability and not rated solely on the number of pills developed. A series of standards, based on graduated degrees of surface change of the fabric type being tested, may be set up to provide a basis for subjective ratings. The visual standards are most advantageous when the laboratory test specimens correlate closely in appearance with worn fabrics and show a similar ratio of pills to fuzz. Counting the pills and weighing their number with respect to their size and contrast, as a combined measure of pilling resistance, is not recommended because of the excessive time required for counting, sizing, and calculating.

5.4 The degree of fabric pilling is evaluated by comparing the tested specimens with visual standards, which may be actual fabrics or photographs of fabrics, showing a range of pilling resistance. The observed resistance to pilling is reported on an

---

<sup>2</sup> *Annual Book of ASTM Standards*, Vol 07.01.

<sup>3</sup> *Annual Book of ASTM Standards*, Vol 07.02.

<sup>4</sup> *Annual Book of ASTM Standards*, Vol 09.02.

<sup>5</sup> Available from American Society for Testing and Materials, 100 Barr Harbor Drive, West Conshohocken, PA 19428. Request ADJD3512.

arbitrary scale ranging from 5 (no pilling) to 1 (very severe pilling).

5.5 This test method is applicable to a wide variety of woven and knitted fabrics that vary in pilling propensity as a result of variations in fiber, yarn and fabric structure, and finish.

**6. Apparatus and Materials**

6.1 *Random Tumble Pilling Tester*<sup>6</sup> (Fig. 1):

6.1.1 *Cork Cylinder Liners*,<sup>7</sup> about 146 mm (5.75 in.) wide by 452 mm (17.81 in) long cut from 1.5-mm (.063-in.) thick flat sheets of Type P2117A material conforming to Classification System F104, Appendix X2. The original surface of the liner, produced by slicing the material, should be used without any further treatment such as sanding. Store liners in original packaging in a cool, dry place.

6.1.2 *Air Injection Device* to give 14-21 kPa (2-3 psi) air pressure in each test chamber, either included in new testers or a modification<sup>8</sup> to older testers.

6.2 *Adhesive*<sup>9</sup>, white all-purpose, for sealing edges of specimens (see 7.1).

6.3 *Plastic Bottle*, with dispensing spout and cap, for use with diluted adhesive.

6.4 *Vacuum Cleaner*, home canister type, to clean specimens after testing.

---

<sup>6</sup> The Random Tumble Pilling Tester and accessories as manufactured by the Atlas Electric Devices Co., 4114 Ravenswood Ave., Chicago, IL 60613, has been found satisfactory.

<sup>7</sup> Cork Liners available from Atlas Electric Devices Co., 4114 Ravenswood Ave., Chicago, IL 60613 and Atlantic Gasket Corp., 3908 Frankford Ave., Philadelphia, PA 19124.

<sup>8</sup> Air Injection Modification Kit for older models is available from Atlas Electric Devices Co., 4114 Ravenswood Ave., Chicago, IL 60613.

<sup>9</sup> Elmer's Glue-All is an example of acceptable adhesive.



**FIG. 1 Random Tumble Pilling Tester**

6.5 Cotton Sliver,<sup>10</sup> 5300 tex (75 grain), 4301 tex, fine cotton, Egyptian Karnak, American Upland, or equivalent, for improving visibility of pills on specimens.

6.6 Apparatus for Fabric Evaluation,<sup>11</sup> (Fig. 2) Facilities—Facilities for illumination (cool white fluorescent tube with correlated color temperature of 4100 to 4500° K) tube) and simultaneous viewing of test specimen and fabric or photograph rating standards. Apparatus and options for visula evaluation are listed in Table 1.

6.7 Standard In-House Pilling Test Fabric, having an established pilling resistance rating for checking machine performance. No universal standard fabric is available. Each test facility must decide on an appropriate fabric.

6.8 Rating Standards:

6.8.1 Fabric—A series of tested specimens of a specific fabric type which shows degree of pilling or other distortion, or both, for each type of fabric to be tested. Store the fabric rating standards and handle them under conditions that will preserve their original form and appearance. The photos should have a dull matte finish and be of the same size as the tested specimen.

6.8.2 Photographic— A set of five photographs, 105-mm square (4.13 in.), numbered 1 to 5 illustrating varying degrees of pilling from “very severe pilling” to “no pilling” such as Adjunct D 3512.<sup>5</sup>

6.9 Facilities for Laundering Samples—If needed.

6.10 Facilities for Dry Cleaning Samples—If needed.

7. Hazardous Materials

7.1 Adhesives used in this test method may be hazardous. Refer to the manufacturer’s material safety data sheets for information

<sup>10</sup> Cotton dyed to a medium gray shade before carding using 0.25 % Pontamine Fast Black E (based on weight a colorfast reactive black dye and standard reactive dyeing procedure. The sole source of cotton or equivalent, supply of the apparatus known to the committee at 82°C (180°F) for 60 min, rinsed and oven-dried this time is available from Atlas Electric Devices Co., 4114 Ravenswood Ave., Chicago, IL 60613. If you are aware of alternate suppliers, please provide this information to ASTM Headquarters. Your comments will receive careful consideration at a meeting of the responsible technical committee, which you may attend.

<sup>11</sup> Available from Standard Scientific Supply Co., 601 West Market St., Bethlehem, PA 18018-5208.

<sup>11</sup> Precision and bias data may be found in ASTM Research Report No. D13-1020 filed at ASTM Headquarters.

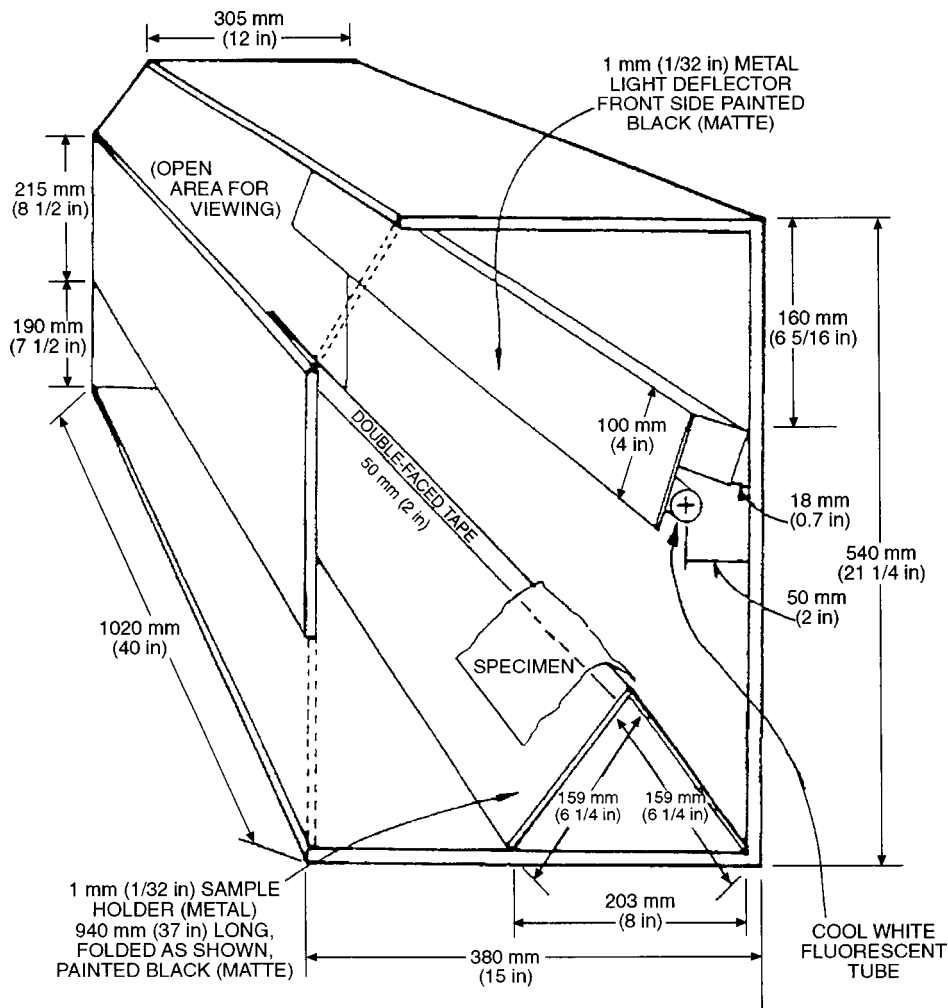

FIG. 2 Apparatus for Fabric Evaluation

**TABLE 1 Viewing Apparatus and Options**

Apparatus	Specimen Preparation
ASTM Lightbox (Fig. 1) <sup>A</sup>	0.78 rad (45°)
Lightbox <sup>B</sup>	0.78 rad (45°)
Lightbox <sup>B</sup>	flat
Lightbox <sup>B</sup>	critical angle
As determined by the buyer and supplier	

<sup>A</sup>The source of supply of the apparatus known to the committee at this time is Standard Scientific Supply Co., 601 West Market Street, Bethlehem, PA 18018-5208. If you are aware of alternate suppliers, please provide this information to ASTM Headquarters. Your comments will receive careful consideration at a meeting of the responsible technical committee, which you may attend.

<sup>B</sup>Available commercially.

on use, handling, storage, and disposal of these products.

## 8. Sampling

8.1 *Primary Sampling Unit*—Consider rolls of fabric or fabric components of fabricated systems to be the primary sampling unit, as applicable.

NOTE 2—An adequate specification or other agreement between the purchaser and the supplier requires taking into account the variability among rolls, bolts, or pieces of fabric and among specimens from a swatch of fabric from a roll, bolt, or piece, or between cartons of garments and among garments within a carton, to provide a sampling plan with a meaningful producer's risk, consumer's risk, acceptable quality level, and limiting quality level.

8.2 *Laboratory Sampling Unit*—From each primary sampling unit take one full-width piece of fabric that is 1 m (1 yd) in length along the selvage (machine direction), after first removing a 1 m (1 yd) length. For fabric components of fabricated systems use the entire system.

8.2.1 For acceptance testing of garments, take one garment from each carton (see Note 2).

## 9. Test Specimens: Selection, Number, and Preparation

9.1 Samples may be washed or dry cleaned before cutting the test specimens, using conditions appropriate for the fabric end use or conditions agreed upon by all interested parties.

9.2 Cut specimens in squares 105 mm (4.13 in.) on the bias at an approximate 0.78 rad (45°) angle to the warp (wale) and filling (course) directions.

9.2.1 Take three specimens from each laboratory unit. Take the specimens evenly spaced across the width of the laboratory sample or from three different panels in a garment. Specimens should be staggered in such a manner that no two specimens contain the same yarns. Avoid areas with wrinkles and other distortions. Unless otherwise specified, do not cut specimens nearer the selvage than one tenth the width of the fabric.

9.3 Mark replicate specimens in one corner on the face of the fabric with the appropriate number 1, 2, or 3.

9.4 If loosely woven specimens fray when applying identification markings, cut the specimens with sides parallel to the warp and filling and ravel the sides no more than 5 mm (0.2 in.) on each side, leaving the fringe.

9.5 Seal the edges of all specimens to a width not exceeding 3 mm (.13 in.) on the face of the fabric with adhesive. Hang the specimens on racks until dry, and in any case for at least 2 h.

NOTE 3—Full-strength adhesive or any dilution down to 1 part adhesive with 1 part water may be used (see 7.1). Pressing the adhesive into the specimen face may be accomplished using the dispensing nozzle in a closed configuration. The rounded end of a glass stirring rod works well, also, but caution should be used to prevent breakage and possible injury from broken glass.

## 10. Preparation of Apparatus

10.1 Fit a cork liner snugly around the inside of a cleaned test chamber with an unused cork surface facing the rotor blades. The side against the chamber may or may not have been used. To eliminate any tendency for the liner to rotate, tape the outside edge of the liner to the chamber wall at the butt joint with a short piece of 25-mm (1-in.) wide masking tape.

10.1.1 Discard cork liners that have been used for 1 h on each surface.

10.2 After every hour of machine running time, remove the liner and clean the impeller by wiping with a cloth wetted in a solution of detergent and water. Allow the chamber to dry before the next use.

10.3 Check the operation of the pilling tester with one or more standard in-house fabrics of known pilling resistance as follows:

10.3.1 If the equipment is in constant use, check the tester at least once a week; if testing is done infrequently, check the equipment each time it is used. Check, also, when test results appear questionable, or following a change in test equipment such as the use of a new shipment of cork liners.

10.3.2 Surface friction of new cork liners can be checked by any convenient means, such as placing a smooth weight on the cork situated on an inclined plane and timing the slide of the weight when the plane is lifted sufficiently to initiate movement of

the weight. Always use the same weight and plane angle. After each test, clean the bottom of the weight by wiping with a cloth wetted in a solution of detergent and water. Wipe dry. Compare data from each shipment to avert problems.

## 11. Conditioning

11.1 Bring the test specimens and cork liners to moisture equilibrium for testing in the standard atmosphere for testing textiles as directed in Practice D 1776 or, if applicable, in the specified atmosphere in which the testing is to be performed.

## 12. Procedure

12.1 Make all tests in the standard atmosphere for testing textiles.

12.2 Make individual test runs in a specific chamber on replicate specimens only.

12.2.1 Place three specimens, all from the same sample, and about 25 mg of ~~5 6-mm (0.2-in.) gray-colored~~ gray-dyed cotton fiber into the test chamber.

NOTE 4—If there is not sufficient material to provide three standard-size specimens, run with the available number of specimens rather than adding a specimen from another fabric, since there may be a strong interaction between fabrics which will create misleading results. Tests run with one or two specimens, while not strictly comparable with standard tests, are considered more indicative than tests that include more than one fabric type.

NOTE ~~5—One 5-mm~~ 5—The mass of a 6-mm long section of ~~5300-tex (75-grain)~~ 4301 tex sliver ~~weighs approximately~~ is about 25 mg.

12.3 Place the cover on the chamber, and set the timer for a running time of 30 min.

NOTE 6—Depending on the nature of the material under test, running times of other than 30 min may be more appropriate for evaluating the pilling tendencies of fabrics; for example, 10-min intervals up to 30 min may be more indicative for certain knit or soft-woven fabrics.

12.4 Turn the motor switch to “ON,” push the “START” button, and start the airflow.

NOTE 7—The use of air injection with all fabrics, woven or knitted, has been found to significantly reduce the likelihood that a specimen will wedge around the impeller or against the wall of the chamber.

12.5 In the course of the run, check each test chamber at frequent intervals. If a specimen wedges around the impeller without tumbling or lies inert on the bottom or side of the chamber, shut off the air, stop the machine, remove the face plate, and free the specimen. Record on the data sheet any hang-ups or other abnormal behavior of the specimens.

12.6 When a specimen wedges around the impeller during a run, stop the test, and clean the impeller blade as directed in 10.2.

12.7 After each time run (see Note 6), remove each specimen and clean off the excess cotton fiber that is not actually entangled in pills using the vacuum cleaner. Firmly grasp the specimen by a corner and allow the vacuum suction to draw the specimen inside. Repeat, holding an adjacent corner. Vacuum all specimens in this manner. Vacuum-clean the test chamber. Clean around the shaft of the impeller using a sharp instrument, such as a pick needle, to remove trapped detritus.

12.8 Evaluate the specimens subjectively as directed in Section 13.

12.9 Repeat 12.3-12.8 for each additional run time for a total of x min (see Note 6). Add another 25 mg (see Note 5) of ~~5 6-mm (0.2-in.) gray-colored~~ gray-dyed cotton fiber into the chamber for each additional run time.

12.10 Testing fabrics with silicone or other fugitive finishes may contaminate the cork liner and consequently alter pilling results (see 1.2). To cope with this problem in the laboratory, make a subsequent test using the used liner surface (on which the silicone-treated fabric was tested) with a standard in-house fabric of known pilling history. If the liner being checked has been contaminated, the pilling level on the standard rating fabric will be different than historical results obtained when testing as in 10.3. Both results should be reported. Similar effects may be produced by other “fugitive” finishes, check the liner after tests on materials with “unknown” finishes.

## 13. Evaluation

13.1 Place each specimen on the double-faced tape in the viewing cabinet (see Fig. 2).

13.1.1 Using ~~suitable rating standards (6.7), and the viewing apparatus and option selected from Table 1 and either suitable fabric evaluation (Fig. 2), or photographic standards (6.7),~~ subjectively rate the appearance of the face (as indicated by the markings and after the respective tumbling times) of each specimen, ~~looking down on the specimens at approximately 0.78 rad (45°), and using the rating standard (6.8) and the following scale (see Note 8). When the appearance of a test specimen falls between that of two rating standards, assign the half value, for example, 3.5 or 2.5. (Note 8):~~

- 5—no pilling
- 4—slight pilling
- 3—moderate pilling
- 2—severe pilling
- 1—very severe pilling

NOTE 8—The ASTM Adjunct ~~12-435120-00, ADJD3512,~~ the apparatus ~~(Fig. 2) for viewing the specimens,~~ and option selected from Table 1, and a minimum of two graders for rating specimens shall be used in referee situations.

~~13.1.2 Average~~

13.2 Place each specimen on the double-faced tape in the viewing cabinet (see Fig. 2).

13.2.1 Average the ratings for the three specimens from each laboratory sampling unit and the average for the lot.



13.23 Check the pilled specimens for nonuniformity of pilling. If the pills are concentrated in any one strip in either fabric direction, or in any one portion of a specimen, report this condition. Strips indicate that different yarns may have been used in making the fabric being tested.

13.34 Check the pilled specimens for evidence of irregular tumbling. If any of the specimens show a high concentration of pills in a general line not parallel to either fabric direction, assume a specimen is wedged around the impeller (see Note 7) for one or more periods during the test. Discard these and repeat the test with new specimens.

13.45 Evaluate the fabric for other surface effects such as fuzzing. It is advisable to have a separate set of in-house fabric rating standards for each surface effect to be rated.

## 14. Report

14.1 State that the specimens were tested as directed in Test Method D 3512. Describe the material or product sampled and the method of sampling used.

14.2 Report the following information for the laboratory sampling unit and for the lot as applicable to a material specification or contract order.

14.2.1 Ratings of each individual specimen, the average rating of the three specimens from each laboratory sampling unit, and the average for the lot,

14.2.2 If the fabric was washed before testing, laundering conditions used,

14.2.3 If the fabric was dry-cleaned before testing, conditions used,

14.2.4 Running times, and

14.2.5 Type of viewing apparatus, viewing option, and rating standard used.

## 15. Precision and Bias

15.1 *Precision*—Interlaboratory Test Data<sup>11</sup>—An interlaboratory test was conducted in 1970 with 14 laboratories testing 12 different fabrics using the Random Tumble Pilling Test procedure. The test results showed that those fabrics with average ratings less than or equal to 2.0, or greater than or equal to 4.0, had high interlaboratory agreement and those fabrics with average ratings between 2.0 and 4.0 had low interlaboratory agreement.

15.2 *Bias*—The procedure of this test method produces a test value that can be defined only in terms of a test method. There is no independent, referee method by which bias may be determined. This test method has no known bias.

## 16. Keywords

16.1 fabric; fuzz; pills

*ASTM International takes no position respecting the validity of any patent rights asserted in connection with any item mentioned in this standard. Users of this standard are expressly advised that determination of the validity of any such patent rights, and the risk of infringement of such rights, are entirely their own responsibility.*

*This standard is subject to revision at any time by the responsible technical committee and must be reviewed every five years and if not revised, either reapproved or withdrawn. Your comments are invited either for revision of this standard or for additional standards and should be addressed to ASTM International Headquarters. Your comments will receive careful consideration at a meeting of the responsible technical committee, which you may attend. If you feel that your comments have not received a fair hearing you should make your views known to the ASTM Committee on Standards, at the address shown below.*

*This standard is copyrighted by ASTM International, 100 Barr Harbor Drive, PO Box C700, West Conshohocken, PA 19428-2959, United States. Individual reprints (single or multiple copies) of this standard may be obtained by contacting ASTM at the above address or at 610-832-9585 (phone), 610-832-9555 (fax), or service@astm.org (e-mail); or through the ASTM website (www.astm.org).*