



Designation: D 4393 – 00

## Standard Test Method for Strap Peel Adhesion of Reinforcing Cords or Fabrics to Rubber Compounds<sup>1</sup>

This standard is issued under the fixed designation D 4393; the number immediately following the designation indicates the year of original adoption or, in the case of revision, the year of last revision. A number in parentheses indicates the year of last reapproval. A superscript epsilon ( $\epsilon$ ) indicates an editorial change since the last revision or reapproval.

### 1. Scope

1.1 This test method covers the determination of peel adhesion of reinforcing fabrics that are bonded to rubber compounds. It is applicable to either woven or parallel cord textile structures from both natural and manmade fibers and to parallel steel cord structures.

1.2 This test method is primarily used to evaluate tire cords and tire cord fabrics, including steel tire cords, using a suitable tire cord adhesive and a suitable rubber compound. This test method may be used to evaluate tire cord adhesives (fabric dip), metallic (usually brass) coatings on steel cord, and the process of adhesive reaction on the cord using one consistent form of tire cord or fabric and one consistent rubber compound. This test method may be used to evaluate cords and fabrics in industrial hose and belting products and other cord or fabric reinforced rubber products.

1.3 Variables that may contribute to differences in results of this test method include adhesive type, adhesive application procedure, adhesive cure, fiber type, construction of cords or reinforcing fabrics, rubber type, rubber cure, rubber thickness, and cord spacing.<sup>2</sup>

1.3.1 The deleterious effect of ozone in combination with atmospheric moisture on the ability of adhesives to bond with rubber requires assiduous protection of cords prior to rubber embedment.<sup>3</sup>

1.4 This test method is written in SI units. The inch-pound units in parentheses are provided in this test method are not necessarily exact equivalents of the SI units. Either system of units may be used in this test method.

1.5 *This standard does not purport to address all of the safety concerns, if any, associated with its use. It is the responsibility of the user of this standard to establish appropriate safety and health practices and determine the applicability of regulatory limitations prior to use.*

### 2. Referenced Documents

#### 2.1 ASTM Standards:

- D 76 Specification for Tensile Testing Machines for Textiles<sup>4</sup>
- D 123 Terminology Relating to Textiles<sup>4</sup>
- D 1566 Terminology Relating to Rubber<sup>5</sup>
- D 2138 Test Methods for Rubber Property—Adhesion to Textile Cord<sup>6</sup>
- D 2229 Test Method for Adhesion Between Steel Tire Cords and Rubber<sup>4</sup>

### 3. Terminology

#### 3.1 Definitions:

3.1.1 *adhesion, n*—the property denoting the ability of a material to resist delamination or separation into two or more layers.

3.1.2 *adhesion, n—in tire fabrics*, the force required to separate a textile material from rubber or other elastomer by a definite prescribed method.

3.1.3 *chafer fabric, n—in tire fabrics*, a woven fabric usually coated with unvulcanized rubber compound, which is laid around the bead of a tire before vulcanization.

3.1.4 *curing, n*—See the preferred term *vulcanization*.

3.1.5 *fabric dip, n—for tire fabrics*, a chemical composition which is applied to a textile cord or fabric to improve its adhesion to rubber compounds.

3.1.6 *holland cloth, n*—a completely filled woven fabric having a smooth gloss finish on both sides used as a separating medium for sheeted rubber compounds.

3.1.7 *rubber, n*—a material that is capable of recovering from large deformations quickly and forcibly, and can be, or already is, modified to a state in which it is essentially insoluble (but can swell) in boiling solvent, such as benzene, methylethyl ketone, and ethanol-toluene azeotrope.

3.1.8 *rubber compound, n—as used in the manufacture of rubber articles*, an intimate mixture of elastomer(s) with all the materials necessary for the finished article.

3.1.9 *rubberize, v*—to impregnate or coat with rubber compound or both.

<sup>1</sup> This test method is under the jurisdiction of ASTM Committee D-13 on Textiles and is the direct responsibility of Subcommittee D13.19 on Tire Cord and Fabrics. Current edition approved May 10, 2000. Published July 2000. Originally published as D 4393 – 85. Last previous edition D 4393 – 98.

<sup>2</sup> Iyengar, Y., “Adhesion Behavior of Nylon Tire Cord/Adhesive/Rubber Systems,” *Journal of Applied Polymer Science*, Vol 13, 1969, pp. 353–363.

<sup>3</sup> Wenghoefer, H. M., “Environmental Effects on RFL Adhesion,” *Rubber Chemistry and Technology*, Vol 47, No. 5, December 1974, pp. 1066–1073.

<sup>4</sup> *Annual Book of ASTM Standards*, Vol 07.01.

<sup>5</sup> *Annual Book of ASTM Standards*, Vol 09.01.

<sup>6</sup> *Discontinued 1990—Replaced by D 4776, D 4777.*

3.1.10 *steel cord, n*—a formed structure made of two or more steel filaments when used as an end product or a combination of strands or filaments and strands.

3.1.11 *steel filament, n*—the individual element in a steel strand or cord.

3.1.12 *stitch, v*—in making rubberized articles, to press uncured rubber compound into or around yarns or cords to form a composite of the materials and to remove entrapped air.

3.1.12.1 *Discussion*—Normally the yarns or cords in the article are parallel. The stitching tool is normally a rolling disk mounted on an axle for manipulation by hand or by machine. The outer edge of the disk is unsharpened but narrower than the intended space between parallel cords. Application of moderate force on this tool accomplishes high local pressure on the surface to which it is applied.

3.1.13 *straightness, n*—in steel cord, the property of a cord characterized by a lack of deviation from its central axis over short lengths of a cord.

3.1.14 *tack, n*—for rubber or rubber compounds, a property that causes two layers of these materials when pressed together to adhere at the area of contact.

3.1.15 *tire cord, n*—as used in this test method, a twisted or formed structure composed of one or more single or plied filaments, strands, or yarns of organic polymer or inorganic material(s).

3.1.16 *tire cord, fabric, n*—a fabric consisting of tire cord warp with widely spaced, single yarn filling.

3.1.17 *vulcanization, n*—an irreversible process, usually accomplished through the application of heat, during which a rubber compound through a change in its chemical structure (for example, cross linking) becomes less plastic and more resistant to swelling by organic liquids, and elastic properties are conferred, improved, or extended over a greater range of temperature.

3.1.18 *weftless fabric, n*—as used in tire building, a sheet of parallel cords surrounded by uncured rubber compound.

3.1.18.1 *Discussion*—Fabric stability, sufficient to ensure that fabric can be moved and handled, is imparted by the unvulcanized rubber rather than by textile yarns (weft or picks) as in woven tire cord fabric.

3.1.19 For definitions of other textile terms used in this test method, refer to Terminology D 123. For definitions of other terms relating to rubber, refer to Terminology D 1566.

#### 4. Summary of Test Method

4.1 *Strap Peel Adhesion From Single Cord*—Two pieces of weftless fabric of sufficient size to cover the curing mold cavity are generated on a rotatable drum (Fig. 1). These two fabrics are laid one against the other, with cords in the same direction, to form the pad (Fig. 2). This pad has a nonstick fabric, such as holland cloth, separating the two fabric layers at one end for a sufficient distance to eventually permit adjacent ends of each fabric layer to be separated after curing and grasped separately in the jaws of a tensile testing machine. The pad is cured in a plunger-type mold (Fig. 3) and cut into straps in the long direction, parallel to that of the cords. The force to peel one fabric layer from the other is determined in a recording tensile testing machine.

4.2 *Strap Peel Adhesion From Tire Cord Fabric*—Two pieces, approximately 100 mm (4 in.) square, are cut from woven fabric. These pieces are assembled on a clean flat surface with sheeted rubber compound and a separating material to accomplish a structure like that of Fig. 2. The assembled test pad is cured between heated platens rather than in the plunger-type mold of Fig. 3. Straps are cut from the cured pad in its long direction parallel to the cords, and the force to peel one fabric layer from the other is determined in a recording tensile test machine.

4.3 *Strap Peel Adhesion From Tire Chafer Fabric, Conveyor Belt Duck, Multi-warp Conveyor Belt, and Other Adhesive Treated Fabrics Other Than Tire Cord Fabric*—Test pads are prepared as in 4.2. Straps may be prepared and cut to

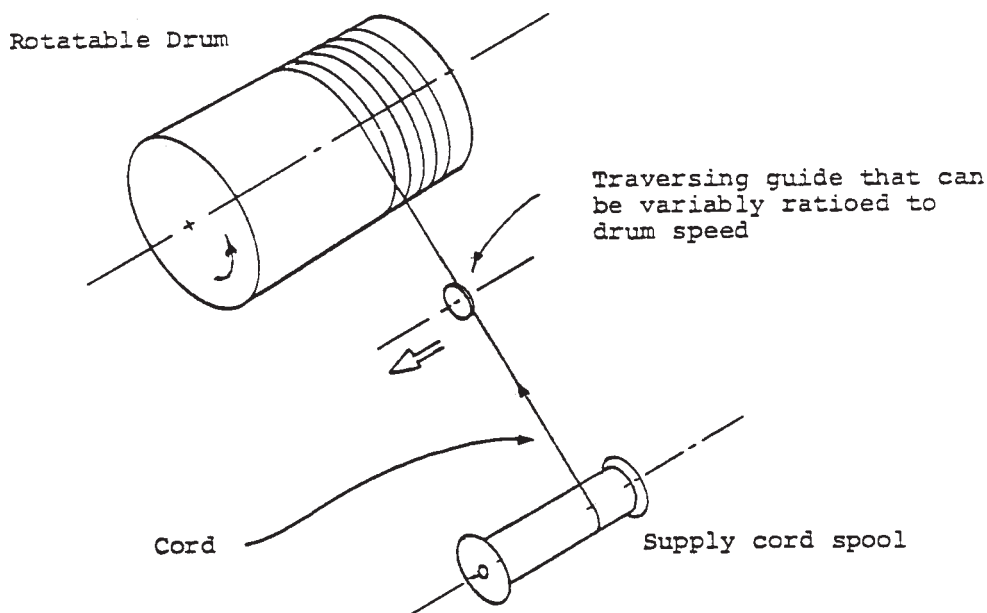

NOTE 1—Laydown of cord to a specified number of cords per metre uses the principles of thread cutting on a machining lathe.

**FIG. 1 Rotatable Drum and Guide Arrangement**

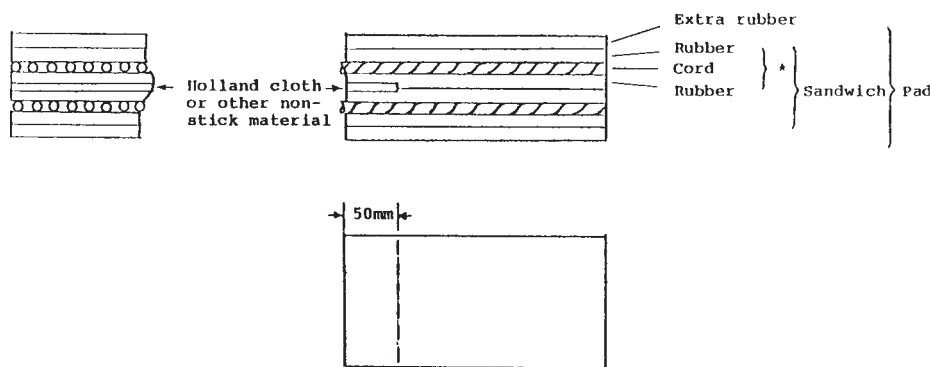

\* One layer of weftless fabric pre-assembled on a rotatable drum in the example of pad building from a single cord.

**FIG. 2 Assembly of Components into a Pad from Which Seven Adhesion Specimens (Straps) May Be Cut After Curing**

accomplish a peel force in either the warp direction or 90° to (across) the warp direction, as agreed between buyer and seller. Separate straps are prepared for warp and across-warp direction except in special cases (see 10.4).

**4.4 Strap Peel Adhesion Simulating Composites Cut From Cross-ply Tires**—Four layers of weftless or woven fabric are assembled with each adjacent cord layer insulated by rubber and assembled to provide cord direction in each layer 90° to each adjacent layer. Straps are cut to provide peeling between the two middle cord layers with peel force direction 45° to the longitudinal axis of the cords.

## 5. Significance and Use

**5.1 Single Test Cord**—Adhesive treating of cords singly or adhesive treating individual ends simultaneously (referred to as “multi-cord treating” as opposed to “fabric treating”) and winding the cords as single ends is the most common laboratory method of preparing reinforcement materials for evaluation in reinforced rubber articles such as tires, belts, and hoses. This system of adhesive treating facilitates the study of a large number of adhesion variables at minimum cost. This test method provides a good comparison of variables on adhesion because it produces both an average numerical value of peel force over several linear centimetres of cord and provides convenient specimens for assessing appearance (see 11.3) of the peeled area as well. It may be used for purchase specification requirements for adhesive treated cords, steel tire cord, adhesives, rubber compounds, or manufacturing control of such products.

**5.1.1** Preparation of weftless fabric from single cord is not recommended for acceptance testing of commercial shipments of tire cord fabric because single cords of long length cannot be conveniently obtained from fabric for drumwinding. See 5.2.2.

**5.1.2** This test method is usually not preferred for acceptance testing of commercial shipments of adhesive treated cord, such as single end cord for hose. The more usual and convenient method for acceptance testing of such single cords is to prepare from a shipment a test piece or article in the same manner as the commercial article to be produced and to test cord-adhesion characteristics in this piece in a manner that compares its adhesion characteristics against a previously

established, acceptable control. “H” and “U” tests (Test Methods D 2138) provide convenient and rapid adhesion results for acceptance testing of textile cords if needed. For steel cord, Test Method D 2229 provides convenient and rapid adhesion results.

**5.2 Using Woven Fabric**—The woven fabric method of 4.2-4.4 is often chosen for rapid adhesion testing of textile woven fabric being adhesive treated in large volume. Fabric is tested “as is” and, through experience, constitutes a valuable process control tool. The same basic test can be conveniently executed by the receiving customer for process control purposes by sampling rubberized fabric from that to be processed into finished rubber articles.

**5.2.1** This test method may be used for acceptance testing of commercial shipments of adhesive treated fabric, but duplicate numerical values for peel force and appearance are not to be expected between two testing locations. Rubber compound differences are only one of many parameters affecting peel force and appearance. Nevertheless, the expected range of values which characterize acceptable adhesion can be determined in any cord-rubber combination with experience. For this reason, the buyer normally establishes a minimum level of adhesion to be obtained by the seller in the seller’s laboratory using either the seller’s standard rubber compound or the buyer’s rubber compound on the fabric made to the buyer’s specification.

**5.2.2** In case of a dispute arising from differences in reported test results when using Test Method D 4393 for acceptance testing of commercial shipments, the purchaser and the supplier should conduct comparative tests to determine if there is statistical bias between their laboratories. Competent statistical help is recommended for the investigation of bias. As a minimum, the two parties should take a group of test specimens which are as homogeneous as possible and which are from a lot of material of the type in question. The test specimens should then be randomly assigned in equal numbers to each laboratory for testing. The average results from the two laboratories should be compared using Student’s t-test for unpaired data and an acceptable probability level chosen by the two parties before testing began. If a bias is found, either its

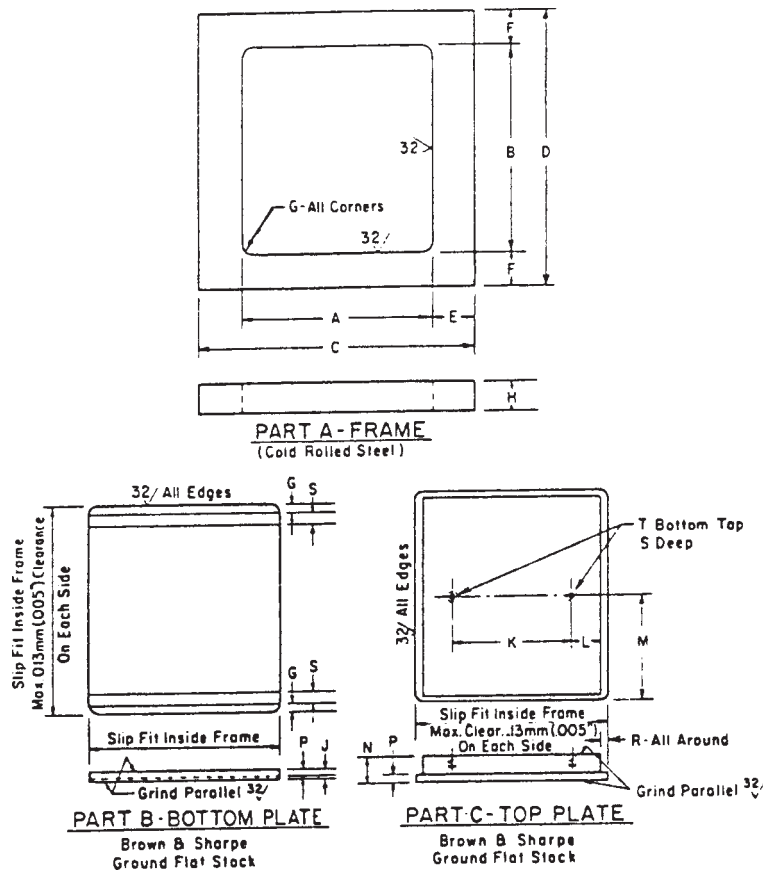

**FIG. 3 Strap Peel Adhesion Testing Specimen Mold**

cause must be found and corrected or the purchaser and the supplier must agree to interpret future test results in the light of the known bias.

## 6. Apparatus and Materials

6.1 *Rotatable Drum*, to build weftless cord-rubber fabric at least 230 mm (9 in.) long in warp direction and 230 mm wide. (Fig. 1).

6.2 *Curing Press*, capable of exerting a force of at least 64 kN (14 400 lbf), equipped with 300 by 300-mm (12 by 12-in.) platens or larger, and capable of being controlled to within 2°C.

6.3 *Plunger-Type Curing Mold*, 225 by 200 mm (9 by 8 in.), in accordance with Fig. 3.

6.4 *Tensile Testing Machine*—Although a CRE tensile testing machine (constant-rate-of extension) is preferred, a CRT Type (constant-rate-of traverse, pendulum type) may be used. The specifications and methods of calibration and verification of these machines shall conform to Specification D 76. The testing machine shall be equipped with an autographic recorder

(rectilinear coordinates preferred) and flat faced clamps of the cam or pneumatic type.

6.5 *Rubber Solvent*, with boiling point in the range from 40 to 150°C (104 to 302°F).

6.6 *Sheeted Rubber Compound*, (sometimes called skim stock) supported on holland cloth or other non-stick separating material. The recommended thickness (gage) of the skim stock varies from 0.4 mm (0.015 in.) for tire cord to 2.0 mm (0.080 in.) for heavy, multiple-warp conveyor belt fabrics.

6.6.1 Rubber stock properties are best maintained by storage in a cool, dry atmosphere. Excessive rubber stock moisture may lower adhesion of some fiber/rubber composites. Storage at 25°C and 30 % relative humidity has been found satisfactory. Rubber moisture content less than 0.40 % does not affect adhesion of most rubber/cord combinations.

6.6.2 Rubber compounds exhibit wide variations in shelf life (properties suitable for good adhesion results) dependent upon both composition and storage condition. Adhesion test

compounds are usually replaced after six months; however, some may require replacement within a few weeks.

6.7 *Chafed Fabric*, for use as backing fabric in building and testing certain cords, especially steel cord (See 9.1.4).

## 7. Sampling

7.1 *Lot Sample*—As a lot sample for acceptance testing, take at random the number of primary sampling units directed in an applicable material specification or other agreement between the purchaser and the supplier. Consider shipping containers of cord and rolls of fabric to be the primary sampling units. Exercise caution in sampling and handling so that samples receive minimum exposure to ambient atmosphere prior to rubber embedment.

NOTE 1—A realistic specification or other agreement between the purchaser and the supplier requires taking into account the variability between primary shipping units and within primary shipping units so as to provide a sampling plan with meaningful producer's risk, consumer's risk, acceptable quality level, and limiting quality level.

7.2 *Laboratory Sample*—As a laboratory sample for acceptance testing, proceed as follows:

7.2.1 For cord, take at random the number of packages per shipping container in the lot sample directed in an applicable material specification or other agreement between the purchaser and the supplier.

7.2.2 For fabric, take a full-width swatch at least 1 m (1 yd) long from the outside of each roll of fabric in the lot sample, after first discarding all fabric from the outside of the rolls that contains creases, fold marks, disturbed weave, or contamination by foreign material.

7.3 *Test Specimens*— Take test specimens as follows:

7.3.1 For cord, prepare 2 specimens from each package in the laboratory sample as directed in Sections 8 and 9.

7.3.2 For fabric, prepare one specimen from each swatch in the laboratory sample as directed in Section 9.

## 8. Preparation of Weftless Fabric

8.1 Affix a section of skim stock on holland cloth to surface of the rotatable drum with skim exposed to receive cords in 8.2.

8.2 Lay test cords with controlled spacing across the face of the skim stock at 1 to 2 N tension. Table 1 specifies cord spacing to be used.

8.2.1 If tackiness of skim stock is insufficient to hold cords in place during drum winding, wipe skim surface before cords are laid down with a sponge dampened in rubber solvent to improve tack.

8.3 Apply a layer of skim stock on top of the cord layer.

8.4 With the holland cloth backing still in place on the skim stock applied in 8.3, use a stitching tool on the face of the drum to press the outer skim around the cords. After stitching the first time, remove the holland cloth and stitch again to force air from the rubber-cord assembly and to press the two skims firmly together with the cord layer in between.

8.5 Remove the now rubberized cord from the drum and lay skim-side down on a clean, flat, non-stick surface.

8.5.1 In general practice, a rotatable drum of sufficient diameter is chosen to permit winding sufficient weftless rubber-cord fabric from which both of the fabric pieces to be assembled as directed in 9.1 can be obtained. Since the final

**TABLE 1 Cord Spacing for Weftless Fabric**

Cord Construction		Cords, m	Cords, in.
Textile Cords			
Denier Units	Decitex Units		
840/2	940 × 2	1100	28
1100/2	1220 × 2	1020	26
1260/2	1400 × 2	980	25
840/3	940 × 3	980	25
840/2/2	940 × 2 × 2	710	18
1680/2	1880 × 2	710	18
1650/2	1840 × 2	980	25
1650/3	1840 × 3	710	18
2200/3	2440 × 3	630	16
1000/2	1100 × 2	1100	28
1000/3	1100 × 3	900	23
1260/3	1400 × 3	790	20
1300/3	1440 × 3	710	18
1500/2	1670 × 2	900	23
1500/3	1670 × 3	710	18
3000/2	3300 × 3	710	18
3000/3	3300 × 3	550	14
Glass Cords			
	15 1/0	900	23
	15 2/0	710	18
	15 3/0	590	15
Steel Cords			
	4 × 0.25	710	18
	4 × 0.28	710	18
	3 × 0.20 + 6 × 0.38	550	14
	3 + 9 × 0.22 + 1 × 0.15 mm	630	16
	3 + 9 + 15 × 0.175 + 1 × 0.15 mm	630	16
	2 + 7 × 0.22 + 1 × 0.15 mm	630	16

cured pad of 9.1 is of sufficient width to cut from it in the cord, lay direction seven individual 25-mm (1-in.) wide specimens, as many as three different test cords may be incorporated into a single pad. In a multi-item pad, orientation of the two weftless fabric pieces must be maintained so that individual cord items to be tested face each other in the final assembly.

## 9. Preparation of Pads and Specimens

### 9.1 Using Single Test Cord:

9.1.1 Cut a 200 by 230-mm (8 by 9-in.) piece from the weftless rubber-cord fabric prepared on the rotatable drum. The long dimension of this fabric is in the warp direction. Remove holland cloth backing and lay freshly-exposed surface up on a clean, nonstick surface.

9.1.2 Place a 50 by 200-mm (2 by 8-in.) strip of holland cloth or other nonadhesive<sup>7</sup> material along cut-cord edge of the weftless fabric and at right angle to the warp.

9.1.3 Cut another piece of rubber-cord fabric containing the same test cord(s) as directed in 9.1.1. Remove holland cloth backing and place freshly-exposed surface against top of the first weftless rubber-cord fabric with the warp cords parallel and one edge of this two-fabric sandwich separated by the nonadhesive material at one cut cord edge as in 9.1.1.

9.1.4 Place additional rubber compound on either side of this sandwich to give a total rubber thickness of 1.3 mm (0.050 in.) outside each cord layer of the sandwich. For steel cord, it may be required to use a backing fabric in place of the

<sup>7</sup> Mylar® Type A-100 polyester film, 0.025 mm (0.001 in.) thick, has been found satisfactory for this purpose.

additional rubber or portion thereof in order to maintain integrity of the specimen during peeling on the tensile test machine.

9.1.5 Trim the assembly to 225 mm (8.88 in.) length (warp direction) and 200 mm (7.88 in.) width and place in preheated mold (Fig. 3).

9.1.6 Mold at time and temperature appropriate for the cure rate of the rubber stock used with 64 kN (14 400 lbf)  $\pm$  1 kN total force on the mold plunger. Remove the specimen from the hot mold as quickly as possible and air-cool the specimen.

9.1.7 Identify the pad and cord items by code numbers.

9.1.8 Cut off approximately a 12-mm (1/2-in.) width strip from both sides and discard.

9.1.9 Cut seven 25-mm (1-in.) wide straps parallel to the fabric warp, and separate the two-branched end by cutting off the top end of the rubber and removing the non-adhesive material.

#### 9.2 *Using Tire Cord Fabric and Other Fabrics:*

9.2.1 Cut two, 100-mm (4-in.) squares at random from the laboratory sample of woven fabric a minimum of 75 mm (3 in.) from fabric selvages unless otherwise directed.

9.2.2 Using 100-mm (4-in.) squares of freshly-exposed rubber compound, build a sandwich of rubber, fabric (cords parallel) and nonstick separating material similar to the sandwich described in Fig. 2 and 9.1.

9.2.2.1 Where fabric surface profile is different in warp and fill direction or differs between “back” and “face,” such as in some multi-warp conveyor belts, a 200 by 400-mm (4 by 8-in.) pad may be desirable for assessing adhesion in warp and across warp direction or assessing back and face separately (see 10.4).

9.2.3 Add rubber to both sides of the sandwich to provide an additional layer of rubber approximately 1.3 mm (0.050 in.) thick on both sides of the sandwich. Holland cloth or other nonstick material should be used as the outside layer on either side of the finished pad to prevent sticking to the platens of the curing press.

9.2.3.1 In densely woven or very heavy fabrics, such as multi-warp conveyor belts, the addition of rubber on the outer sides of the primary fabric-rubber-fabric sandwich is not required.

9.2.4 Place the completed pad between platens of a preheated curing press and cure at a time and temperature appropriate for the cure rate of the rubber stock. Total force on the platens is to be established based on the characteristics of the rubber/cord combination and the number of pads being cured at one time. Remove the specimen(s) from the hot platens as quickly as possible after curing is completed, and cool the specimen at ambient temperature.

9.2.5 Identify the pad by a numbering system to identify the laboratory sample being tested.

9.2.6 Cut a single, 25-mm (1-in.) wide strip from the center of the pad parallel to the warp and separate the two-branched end by removing the nonadhesive material.

9.2.6.1 An alternative in special situations to cutting 25-mm (1-in.) wide strips for testing is to provide a 25-mm wide area of bonded fabric layers in the cured pad by cutting a 25-mm wide window in a sheet of holland cloth the size of the pad itself. This windowed nonadhesive layer is used in place of the

nonadhesive material specified in 9.1.2. The entire pad is then peeled on the tensile test machine without prior cutting of a 25-mm wide strip as specified in 9.2.6.

#### 9.3 *Using a Specimen Simulating a Section from a Cross-Ply Tire:*

9.3.1 Prepare pads as in 9.1 or 9.2, except assemble fabric layers to be peeled one from another with cord directions 90° to one another.

9.3.2 Cross-ply specimens require a backing fabric to maintain integrity of the specimen during peeling on the tensile test machine. In place of the additional rubber or as a part thereof on the outer sides of the primary fabric-rubber-fabric sandwich, place on the following:

9.3.2.1 An additional layer of the fabric being tested but with its cord direction 90° to the layer it adjoins.

9.3.2.2 A layer of chafer fabric with its warp direction either parallel or 90° to the cord direction of the fabric in the primary test sandwich.

9.3.3 Proceed as in 9.1 or 9.2 to obtain cured pads, but cut 30-mm test strips 45° to the warp direction of the fabric being tested.

9.3.4 After 30-mm strips have been cut from the pad, a shallow, longitudinal, 2 to 3-mm deep cut must be made on the outside edges between the two layers of test fabric prior to peeling on the tensile test machine in order to confine the peeling between these two layers. The 4 to 5-mm wider specimen in 9.3.3 results in a peeled surface more nearly equivalent in width after cutting outside edge to those of 9.1 and 9.2.

9.3.4.1 The alternative of a windowed sheet of holland cloth as in 9.2.6.1, laid with the longitude of its opening 45° to the warp direction of the test fabric, may be used to obviate the shallow cut specified in 9.3.4.

9.3.4.2 Experience has shown that peel force and appearance are generally lower in cross-ply specimens than with same materials tested in parallel specimens.

## 10. Procedure

10.1 Age straps for 8 h minimum, 4 days maximum, at ambient room temperature unless otherwise agreed between buyer and seller (immediate testing is sometimes preferred).

10.2 Test the straps at room temperature for peel strength in a tensile testing machine with an autographic recorder. Set the crosshead speed for 100 or 125 mm per min for tire cord and 50  $\pm$  5 mm/min for chafer or other square woven fabric. Set the recorder chart for approximately half the crosshead speed.

10.3 If specimens are to be tested hot, environment around specimens during testing should be controlled at 120  $\pm$  2°C. Specimens should be preheated at 120°C for 20  $\pm$  2 min and, after clamping in test machine, should be held 60  $\pm$  10 s before starting crosshead to peel the specimen.

10.4 In specimens where experience shows that peeling occurs principally at the fabric face at which rupture initiates, rather than randomly or within the cured rubber compound, or both, or where fabric surfaces are patterned or dissimilar, such as some multi-warp conveyor belts, it may be desirable to encourage failure at a particular rubber/fabric interface within a single specimen. With the specimen in the jaws of the tensile testing machine and under a tension less than that required to

peel the specimen, stop the crosshead and cut through the rubber separating the two fabric layers to the surface of one of the fabric layers. Restart movement of the crosshead, and peel a sufficient portion to obtain a peel force reading. Stop the crosshead and cut through the rubber to the opposite fabric face. Proceed to peel this second rubber fabric interface. Peel force in Section 11 shall be calculated separately for each face.

**11. Calculations**

11.1 Establish the average separation force in the specimen, or at a particular rubber/cord interface. Since there is a characteristic peak in force at beginning of peel, ignore the first 10 to 15 mm after this first high peak, and interpret the remaining high and low peaks (oscillations) of the separation force in the next 25 to 200 mm of the specimen by one of the following options:

11.1.1 *Option 1*—Establish a mid-line between the high and low peaks of force.

11.1.2 *Option 2*—Establish an average of the upper peaks of the oscillating force.

11.1.3 *Option 3*—With computerized read-out, measure the work (area) beneath the oscillations, and calculate average level of force multiplied by crosshead travel (distance) to produce this work area. Or, if tensile testing machine has such capability, average separation force may be read directly from the instrument display.

11.2 The adhesion force (force to separate the layers) is the average strap peel force of the specimen in newtons (pounds). Determine adhesion force by one of the options in 11.1.

11.3 Determine appearance rating of the peeled area by visually judging the least rubber covered fabric face and applying the following rating scale to the nearest 10 %:

Rating	Description of Peeled Surface, Rubber Coverage, %
0	Zero
1	10
2	20
3	30
4	40
5	50
6	60
7	70

8	80
9	90
10	100

**12. Report**

12.1 State that the tests were performed as directed in Test Method D 4393. Describe the products sampled and the method of sampling used.

12.2 Report the following information:

12.2.1 Cord or fabric identification and construction.

12.2.2 Adhesive identity, percent dip pick-up, processing conditions (time, temperature, tension).

12.2.3 Rubber stock identification, gage (thickness), and curing conditions.

12.2.4 Average value of adhesion force for straps.

12.2.5 Average value of appearance of peeled straps if requested.

12.2.6 Whether tested “cold” (20 to 30°C) or “hot” (120°C).

12.2.7 Identify which option (1, 2 or 3) of 11.1 was used to determine adhesion peel force.

12.2.8 If other than tire cord fabric, identify whether peel direction was in warp or across warp direction. If peel site was manipulated in the tensile test machine as directed in 10.4, identify which fabric face was peeled.

12.2.9 Any deviations from specified conditions. Peeling in a direction 45° to that of the warp direction of the test fabric, as in cross-ply specimens, should be noted as a deviation in strap peel adhesion. Note testing on CRT tester as a deviation, since separation rate and results will differ from those from a CRE tester.

**13. Precision and Bias**

13.1 *Precision*—The precision of Test Method D 4393 is to be established.

13.2 *Bias*—No justifiable statement can be made on the bias of Test Method D 4393 for measurement of adhesion since the true value cannot be established by an accepted referee method.

**14. Keywords**

14.1 adhesion; steel cord; steel fabric; tire cord; tire fabrics

*ASTM International takes no position respecting the validity of any patent rights asserted in connection with any item mentioned in this standard. Users of this standard are expressly advised that determination of the validity of any such patent rights, and the risk of infringement of such rights, are entirely their own responsibility.*

*This standard is subject to revision at any time by the responsible technical committee and must be reviewed every five years and if not revised, either reapproved or withdrawn. Your comments are invited either for revision of this standard or for additional standards and should be addressed to ASTM International Headquarters. Your comments will receive careful consideration at a meeting of the responsible technical committee, which you may attend. If you feel that your comments have not received a fair hearing you should make your views known to the ASTM Committee on Standards, at the address shown below.*

*This standard is copyrighted by ASTM International, 100 Barr Harbor Drive, PO Box C700, West Conshohocken, PA 19428-2959, United States. Individual reprints (single or multiple copies) of this standard may be obtained by contacting ASTM at the above address or at 610-832-9585 (phone), 610-832-9555 (fax), or service@astm.org (e-mail); or through the ASTM website (www.astm.org).*