



Standard Guide for Estimating the Magnitude of Variability from Expected Sources in Sampling Plans¹

This standard is issued under the fixed designation D 4854; the number immediately following the designation indicates the year of original adoption or, in the case of revision, the year of last revision. A number in parentheses indicates the year of last reapproval. A superscript epsilon (ε) indicates an editorial change since the last revision or reapproval.

1. Scope

1.1 This guide serves as an aid to subcommittees in writing specifications and sampling procedures.

1.2 The guide explains how to estimate the contributions of the variability of lot sampling units, laboratory sampling units, and specimens to the variation of the test result of a sampling plan.

1.3 The guide explains how to combine the estimates of the variability from the three sources to obtain an estimate of the variability of the sampling plan results.

1.4 The guide is applicable to all sampling plans that produce variables data (Note 1). It is not applicable to plans that produce attribute data, since such plans do not take specimens in stages, but require that specimens be taken at random from all of the individual items in the lot.

NOTE 1—This guide is applicable to all sampling plans that produce variables data regardless of the kind of frequency distribution of these data, because no estimates are made of any probabilities.

1.5 This guide includes the following topics:

Topic Title	Section Number
Scope	1
Referenced Documents	2
Terminology	3
Significance and Use	4
Sampling Plans Producing Variables Data	5
Reducing Variability of Sampling Results	6
Keywords	7
Analysis of Data Using ANOVA	Annex A1
A Numerical Example	Annex A2

2. Referenced Documents

2.1 ASTM Standards:

- D 123 Terminology Relating to Textiles²
- D 2904 Practice for Interlaboratory Testing of a Textile Test Method that Produces Normally Distributed Data²
- D 4271 Practice for Writing Statements on Sampling in Test Methods for Textiles³
- D 4467 Practice for Interlaboratory Testing of a Textile Test Method that Produces Non-Normally Distributed Data³

¹ This guide is under the jurisdiction of ASTM Committee D13 on Textiles and is the direct responsibility of Subcommittee D13.93 on Statistics.

Current edition approved May 15, 1995. Published July 1995. Originally published as D 4854 – 88. Last previous edition D 4854 – 91.

² Annual Book of ASTM Standards, Vol 07.01.

³ Annual Book of ASTM Standards, Vol 07.02.

E 456 Terminology Relating to Quality and Statistics⁴

2.2 ASTM Adjuncts:

TEX-PAC⁵

NOTE 2—Tex-Pac is a group of PC programs on floppy disks, available through ASTM Headquarters, 100 Barr Harbor Drive, Conshohocken, PA 19428, USA. The calculations described in the annexes of this guide, including the cost comparisons of various sampling plans, can be conducted using one of these programs.

3. Terminology

3.1 Definitions:

3.1.1 *analysis of variance (ANOVA)*, *n*—a procedure for dividing the total variation of a set of data into two or more parts, one of which estimates the error due to selecting and testing specimens and the other part(s) possible sources of additional variation.

3.1.2 *attribute data*, *n*—observed values or determinations which indicate the presence or absence of specific characteristics.

3.1.3 *component of variance*, *n*—a part of a total variance identified with a specific source of variability.

3.1.4 *degrees of freedom*, *n*—for a set, the number of values that can be assigned arbitrarily and still get the same value for each of one or more statistics calculated from the set of data.

3.1.4.1 *Discussion*— For example, if only an average is specified for a set of five observations, there are four degrees of freedom since the same average can be obtained with any values substituted for four of the observations as long as the fifth value is set to give the correct total. If both the average and standard deviation have been specified, there are only three degrees of freedom left.

3.1.5 *determination value*, *n*—the numerical quantity calculated by means of the test method equation from the measurement values obtained as directed in a test method. (*Syn.* determination) (See also *observation*.)

3.1.6 *laboratory sample*, *n*—a portion of material taken to represent the lot sample, or the original material, and used in the laboratory as a source of test specimens.

3.1.7 *lot sample*, *n*—one or more shipping units taken to represent an acceptance sampling lot and used as a source of laboratory samples.

⁴ Annual Book of ASTM Standards, Vol 14.02.

⁵ PC programs on floppy disks are available through ASTM. For a 3½ inch disk request PCN:12-429040-18, for a 5¼ inch disk request PCN:12-429041-18.

3.1.8 *mean square—in analysis of variance*, a contraction of the expression “mean of the squared deviations from the appropriate average(s)” where the divisor of each sum of squares is the appropriate degrees of freedom.

3.1.9 *observation, n*—(1) the process of determining the presence or absence of attributes or making measurements of a variable, (2) a result of the process of determining the presence or absence of an attribute or making a measurement of a variable. (Compare *measurement value, determination value, and test result*.)

3.1.10 *precision, n*—the degree of agreement within a set of observations or test results obtained as directed in a method.

3.1.10.1 *Discussion*—The term “precision,” delimited in various ways, is used to describe different aspects of precision. This usage was chosen in preference to the use of “repeatability” and “reproducibility” which have been assigned conflicting meanings by various authors and standardizing bodies.

3.1.11 *random sampling, n*—the process of selecting units for a sample of size n in such a manner that all combinations of n units under consideration have an equal or ascertainable chance of being selected as the sample. (*Syn.* simple random sampling and sampling at random.)

3.1.12 *sample, n*—(1) a portion of a lot of material which is taken for testing or record purposes; (2) a group of specimens used, or observations made, which provide information that can be used for making statistical inferences about the population(s) from which they were drawn. (See also *lot sample, laboratory sample, and specimen*.)

3.1.13 *sampling plan, n*—a procedure for obtaining a sample.

3.1.14 *sampling plan result, n*—the number obtained for use in judging the acceptability of a lot when applying a sampling plan.

3.1.15 *sampling unit, n*—an identifiable, discrete unit or subunit of material that could be taken as part of a sample.

3.1.16 *specimen, n*—a specific portion of a material or laboratory sample upon which a test is performed or which is taken for that purpose. (*Syn.* test specimen.)

3.1.17 *sum of squares—in analysis of variance*, a contraction of the expression “sum of the squared deviations from the appropriate average(s)” where the average(s) of interest may be the average(s) of a specific subset(s) of data or of the entire set of data.

3.1.18 *test result, n*—a value obtained by applying a test method, expressed either as a single determination or a specified combination of a number of determinations.

3.1.19 *variables data, n*—measurements which vary and may take any of a specified set of numerical values.

3.1.20 *variance, σ^2 , n*—of a population, a measure of the dispersion of members of the population expressed as a function of the sum of the squared deviations from the population mean.

3.1.21 *variance, s^2 , n*—of a sample, a measure of the dispersion of variates observed in a sample expressed as a function of the squared deviations from the sample average.

3.1.22 For definitions of textile terms, refer to Terminology D 123. For definitions of statistical terms, refer to Terminology

D 123 or Terminology E 456, or appropriate textbooks on statistics.

4. Significance and Use

4.1 This guide is useful in estimating the variation due to lot sampling units, laboratory sampling units, and specimen selection and testing during the sampling and testing of a lot of material.

4.2 Estimates of variation from the several sources will make it possible to write sampling plans which balance the cost of sampling and testing with the desired precision of the plan.

4.3 This guide is useful in: (1) designing process controls and (2) developing sampling plans as parts of product specifications.

4.4 This guide can be used for designing new sampling plans or for improving old plans.

4.5 This guide is concerned with the process of sampling. This is unlike Practice D 2904 or Practice D 4467 which are concerned with the process of testing.

4.6 Studies based on this guide are applicable only to the material(s) on which the studies are made. If the conclusions are to be used for a specification, then separate studies should be made on three or more kinds of materials of the type on which the test method may be used and which produce test results covering the range of interest.

5. Sampling Plans Producing Variables Data

5.1 For the results of using this guide to be completely valid, it is necessary that all of the sampling units at every stage be taken randomly. It is not always practical to achieve complete randomness, but every reasonable effort should be made to do so.

5.2 In sampling plans which produce variables data, there are three stages in which variation can occur. For a schematic representation of these three stages see Fig. 1 (see also Practice D 4271):

5.2.1 *Lot Sample*—Variation among the averages of the sampling units within a lot sample is due to differences between such items as cases, cartons, and bolts, variation among laboratory samples plus test method error and differences among specimens. To estimate variation due to lot sampling units alone, proceed as directed in 5.3 and 5.4.

5.2.2 *Laboratory Sample*—Within the lot sampling units, variation among the averages of the laboratory sampling units is due to differences among such items as cones within cases, garments within cartons, and swatches within bolts, plus test method error and differences among specimens. To estimate variation due to laboratory sampling units alone, proceed as directed in 5.3 and 5.4.

5.2.3 *Specimens*—Variation among determination values on specimens is due to the test method error and the differences among specimens within laboratory sampling units such as cones, garments, and swatches. Usually it is not feasible to separate these two errors. To estimate the variation among specimens proceed as directed in 5.3 and 5.4.

5.3 If a sampling plan has already been put into operation, or if a new plan is proposed, put it into operation, and collect the resulting data. In the case of either an old plan or a new plan, obtain at least two sampling units at each of the stages of

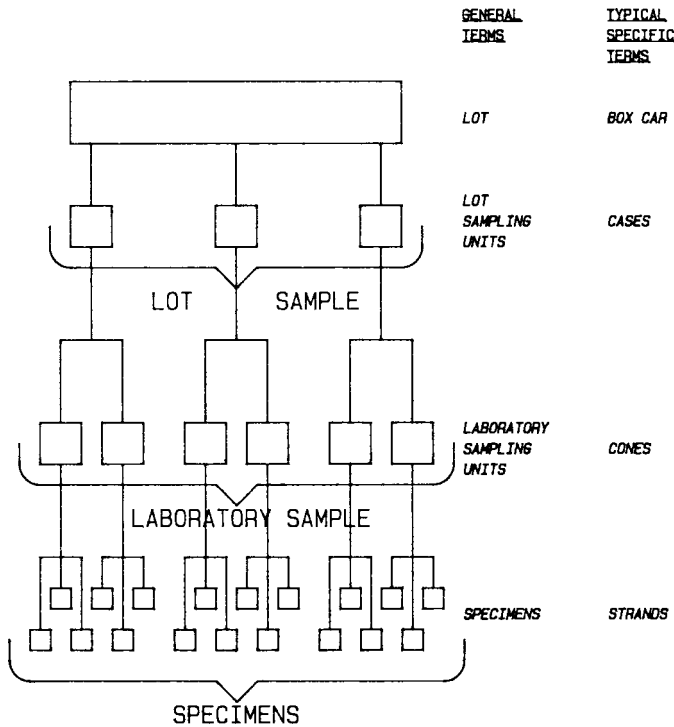

FIG. 1 Sampling Plan—Three Stages

sampling. Sample at least two lots and make an ANOVA for each lot as directed in Annex A1. Continue collecting data for successive lots and make a new ANOVA of the data for each lot. Tabulate the resulting sums of squares, degrees of freedom, and mean squares in a format like that of Table A2.3. Calculate the totals for the sums of squares and for the degrees of freedom to date and calculate the combined mean squares for the lots sampled to date. Continue until the results become stable, that is, until the estimates of the mean squares change very little with additional use of the sampling plan.

5.4 After the estimates of the mean squares have stabilized, do any desired pooling of sums of squares and degrees of freedom (see Note 3). Calculate the components of variance for

each of the stages, using the equations for mean squares composition in Table A1.1 or Table A1.2. Details of how to make these calculations are shown in Annex A1.

NOTE 3—There is disagreement among statisticians on if and when to pool sums of squares and degrees of freedom. This guide recommends pooling under certain circumstances. When and how to pool is discussed in A1.2.1, A1.2.2, A1.2.3, and A1.3.1.

6. Reducing Variability of Sampling Results

6.1 Variability of Sampling Results—Calculate the estimated variance of the sampling plan result (average of all specimen determinations), v , for several sampling plans, using Eq 1:

$$v = L/n + T/mn + E/mnk \tag{1}$$

where:

- v = estimated variance of sampling plan results,
- L = mean squared deviation due to variation among lot sampling units,
- n = number of sampling units in the lot samples,
- T = mean squared deviation due to laboratory samples,
- m = number of laboratory sampling units from one lot sampling unit,
- E = mean squared deviation due to testing specimens, and
- k = number of specimens per laboratory sampling unit.

6.1.1 The values of L , T , and E are obtained by the use of analysis of variance and estimation of the components of variance as directed in 5.3 and 5.4, and explained in the annexes.

6.2 Sampling Plan Choice—Other things being equal, from those sampling plans examined as directed in 6.1, choose the plan which has an acceptable variability with an acceptable cost. Once the sizes of L , T , and E have been determined, both the anticipated variability and cost of obtaining a sampling result for any desired combination of m , n , and k may be calculated. See Annex A2 and Table A2.4.

7. Keywords

7.1 sampling plans; statistics; variability

ANNEXES

(Mandatory Information)

A1. ANALYSIS OF DATA USING ANOVA

A1.1 Sampling Stages—Data taken as directed in 5.3 will be in three, two, or one stage as follows:

A1.1.1 Three-Stage Sampling—For a sampling plan having distinct sampling units in the lot sample, laboratory samples, and specimens, the ANOVA takes the form of lot sampling units with two stages of subsampling (laboratory sampling units within lot samples and specimens within laboratory sampling units). See A1.2.

A1.1.2 Two-Stage Sampling—For a sampling plan having distinct sampling units in the lot sample, but the laboratory

sampling units serve as test specimens, the ANOVA takes the form of lot sampling units with one stage of subsampling (specimens within a unit of the lot sample). See A1.3.

A1.1.3 One-Stage Sampling—For a sampling plan in which the lot sampling units serve as specimens, there are no other sources of variability than specimens to estimate. See A1.4.

A1.2 ANOVA for Three-Stage Sampling—(For a numerical example, see Annex A2.) For a sampling plan having distinct lot sampling units, laboratory samples, and specimens, make

the following calculations:

- (1) = Square the determination value for each specimen tested and sum the squares.
- (2) = Obtain the total of the determination values for each laboratory sampling unit, square each total, sum the squares, and divide this sum by the number of specimens tested per laboratory sampling unit.
- (3) = Obtain the total of the determination values for each lot sampling unit, square each total, sum these squares, and divide this sum by the number of specimens tested in the lot sampling unit.
- (4) = Obtain the total of the determination values of all specimens, square the total, and divide the squared total by the total number of specimens tested in all lot sampling units.

Using these terms, form an ANOVA table in the format shown as Table A1.1. In that table the symbols are as specified in 6.1 (Note A1.1).

NOTE A1.1—The complete titles of the sources of variation are: lot sampling units within the lot sample, laboratory sampling units within the laboratory samples within lot samples, and specimens within the laboratory sampling units within laboratory samples within lot samples.

A1.2.1 If the estimate of the mean square for lot samples is less than or equal to that for laboratory samples, it means that all of the variation in lot samples may be explained by the variation in laboratory samples. In this case, set $L = 0$, and pool the mean squares for lot and laboratory samples to give a new estimate of the mean square for laboratory samples: $[(2)-(4)]/(mn - 1)$. Rewrite the ANOVA table, omitting the lot sample line, replacing the sum of squares for laboratory samples with $[(2)-(4)]$, the degrees of freedom with $(mn - 1)$, and the mean square with $[(2)-(4)]/(mn - 1)$.

A1.2.2 If the estimate of the mean square for laboratory samples is less than or equal to that for specimens, it means that all of the variation in laboratory samples may be explained by the variation in specimens. In this case, set $T = 0$, and pool the mean squares for laboratory samples and specimens to give a new estimate of the mean square for specimens: $[(1)-(3)]/n(mk - 1)$. Rewrite the ANOVA table, omitting the laboratory sample line, replacing the sum of squares for specimens with $[(1)-(3)]$, the degrees of freedom with $n(mk - 1)$, and the mean square with $[(1)-(3)]/n(mk - 1)$.

A1.2.3 If the pooled mean square for lot samples and laboratory samples is less than, or equal to that for specimens, this means that all of the variation in the sampling may be explained by the variation in specimens. In this case, set $L = T$

= 0, and pool the mean squares of all of the sources of variation to give another estimate of the mean square for specimens: $[(1)-(4)]/(mnk - 1)$. Rewrite the ANOVA table, omitting the lot and laboratory sample lines, replacing the sum of squares for specimens with $[(1)-(4)]$, the degrees of freedom with $(mnk - 1)$, and the mean square with $[(1)-(4)]/(mnk - 1)$.

A1.3 ANOVA for Two-Stage Sampling—For a sampling plan in which the laboratory samples serve as test specimens, make the following calculations:

- (1) = Square the determinations for each specimen and sum the squares.
- (2) = Obtain the total of the determinations for each lot sampling unit, square each total, sum these squares, and divide this sum by the number of specimens in each lot sampling unit.
- (3) = Obtain the grand total of the determinations for all specimens, square the total, and divide the squared total by the number of specimens in all lot sampling units.

Using these terms, form an ANOVA table in the format shown as Table A1.2. In this table the symbols are as specified in 6.1 (Note A1.2).

NOTE A1.2—The complete titles of the sources of variation are: sampling units in the lot sample and specimens within sampling units in the lot sample.

A1.3.1 If the estimate of the mean square for lot samples is less than or equal to that for specimens, it means that all of the variation in lot samples may be explained by the variation in specimens. In this case, set $L = 0$, and pool the mean squares for lots and specimens: $[(1)-(3)]/(nk - 1)$. Rewrite the ANOVA table, omitting the lot sample line, replacing the sum of squares for specimens with $[(1)-(3)]$, the degrees of freedom with $(nk - 1)$, and the mean square with $[(1)-(3)]/(nk - 1)$.

A1.4 Analysis of One-Stage Sampling—For a sampling plan in which the lot sampling units also serve as laboratory sampling units and as specimens, make the following calculations:

- (1) = Square the determinations for each specimen and sum the squares.
- (2) = Obtain the grand total of determinations for all specimens, square the total, and divide this squared total by the number of specimens.

A1.4.1 Calculate E using:

$$E = [(1) - (2)]/(k - 1) \tag{A1.1}$$

TABLE A1.1 Format for a Three-Stage ANOVA Table

Source of Variation	Sum of Squares	Degrees of Freedom	Mean Squares	Mean Squares Composition
Lot Samples	(3)–(4)	$n - 1$	A	$E + kT + kmL$
Lab Samples	(2)–(3)	$n(m - 1)$	A	$E + kT$
Specimens	(1)–(2)	$mn(k - 1)$	A	E
Total	(1)–(4)	$mnk - 1$		

^A Each mean square is estimated by dividing a sum of squares by its corresponding degrees of freedom.

TABLE A1.2 Format for a Two-Stage ANOVA Table

Source of Variation	Sum of Squares	Degrees of Freedom	Mean Squares	Mean Squares Composition
Lot Samples	(2)–(3)	$n - 1$	A	$E + kL$
Specimens	(1)–(2)	$n(k - 1)$	A	E
Total	(1)–(3)	$nk - 1$		

^A Each mean square is estimated by dividing a sum of squares by its corresponding degrees of freedom.

where E and k are defined in 6.1.

A1.5 Components of Variance—For ANOVA for three-stage or two-stage sampling, calculate the estimates of the components of variance, L , T , and E , by using the following procedure. The last column in the ANOVA table gives a formula which describes the composition of the mean squares

on the same line. After all pooling has been done, set the formula equal to the mean squares of the same line of the table. Solve for each component of variance. Remember that some components may have been set equal to zero. See A1.4.1 for instructions on calculating the component of variance for a one-stage sampling plan.

A2. A NUMERICAL EXAMPLE

A2.1 Specification—A specification, FTRC 100, to accept a shipment of cases of cones of 20's rayon yarn required the average result of testing three specimens from each of two cones taken from each of three cases to have a strength of at least 5.56 N (1.25 lbf). This plan produces a lot sample of three cases, three laboratory samples of two cones each, and three specimens taken from each cone for a total of 18 specimens (Fig. 1).

A2.1.1 Table A2.1 shows the sampling and testing results from one lot of yarn.

A2.2 Calculation for ANOVA—Calculations for the analysis of variance were done as directed in Annex A1:

A2.2.1 For Lot 1, the calculations directed in A1.2 give the following results, which were used to construct Table A2.2:

- | | |
|----------------|----------------|
| (1) = 44.97; | (2) = 44.7033; |
| (3) = 44.5017; | (4) = 44.4939. |

A2.3 Calculation of Mean Squares for Successive Lots—The sums of squares, degrees of freedom, and mean squares for the first two lots sampled were posted in Table A2.3. The sums of squares and degrees of freedom to date were posted and the mean squares to date calculated. Since the estimates of the mean squares had not stabilized (see 5.3), another lot was sampled, the data analyzed and posted, and the calculations of the cumulative mean squares made. This sequence was repeated until the estimates of the mean squares had all stabilized after the 8th lot was sampled. Since the mean square for lot samples is smaller than the mean square for lab samples, the estimated mean squares after pooling are as shown in Table A2.4.

A2.4 Calculation of Components of Variance—Calculation of the components of variance was done as directed in A1.5,

TABLE A2.2 Sampling Specification FTRC 100, Lot Number ABC-123—ANOVA Table

Source of Variance	Sum of Squares	Degrees of Freedom	Mean Squares	Mean Squares Composition
Lot Samples	0.0078	2	0.0039	$E + 3T + 6L$
Lab Samples	0.2016	3	0.0672	$E + 3T$
Specimens	0.2667	12	0.0222	E
Total	0.4761	17		

using the data of Table A2.4. The results of these calculations are: $L = 0$, $T = (0.0279 - 0.0198)/3 = 0.0027$, and $E = 0.0198$.

A2.5 Calculation of Sampling Plan Variance—Estimates of the variance of the average for several sampling plans were made, using the components of variance calculated in A2.4, and Eq 1 from 6.1. The results of these calculations are shown in Table A2.5. The original plan was: take three lot sampling units, take two laboratory sampling units from each lot sampling unit, and take three specimens from each laboratory sampling unit. This plan gives $v = 0/3 + 0.0027/6 + 0.0198/18 = 0.00155$. The \sqrt{v} is 0.039, the standard deviation of averages for this sampling plan is in pounds-force.

A2.6 Sampling and Testing Costs—In a study beyond the scope of this guide, costs of sampling and testing were found to be: \$5.13 to take one lot sampling unit; \$1.00 to take one laboratory sampling unit; and \$3.50 to take and test one specimen. The costs of the several sampling plans studied are shown in Table A2.5. The total cost of a sampling plan in dollars is calculated using the following equation:

$$\text{Total Cost} = nl + mnt + mnke \quad (\text{A2.1})$$

where:

- l = cost in dollars of taking one lot sampling unit,
- t = cost in dollars of taking one laboratory sampling unit,
- e = cost in dollars of taking and testing one specimen, and

n , m , and k are defined in 6.1.

A2.7 Sampling Plan Choice—Sampling Plan 5 from Table A2.5 might be a good choice: from each lot take one lot sampling unit; seven laboratory sampling units from the lot sampling unit; and test two specimens from each laboratory sampling unit. This plan will have essentially the same variation, but costs less than the present sampling Plan 9 in Table A2.5

TABLE A2.1 Breaking Strength in Pounds-Force—Sampling Specification FTRC 100, Lot Number ABC-123

Lab Sample	Specimen	Lot Sample		
		Case 1	Case 2	Case 3
Cone 1	1	1.7	1.3	1.5
	2	1.6	1.4	1.4
	3	1.8	1.5	1.7
Cone Total		5.1	4.2	4.6
Cone 2	1	1.3	1.7	1.6
	2	1.5	1.9	1.7
	3	1.7	1.5	1.5
Cone Total		4.5	5.1	4.8
Case Total		9.6	9.3	9.4
Lot Sample Total			28.3	

TABLE A2.3 Sampling Specification FTRC 100—ANOVA Summary for Successive Lots^A

Lot	Lot Samples			Lab Samples			Specimens		
	SS	df	MS	SS	df	MS	SS	df	MS
1	0.0078	2	0.0039	0.2016	3	0.0372	0.2667	12	0.0222
2	0.0160	2	0.0080	0.1467	3	0.0489	0.2036	12	0.0170
1&2	0.0238	4	0.0060	0.3483	6	0.0581	0.4703	24	0.0196
3	0.0204	2	0.0102	0.1056	3	0.0352	0.2387	12	0.0199
1-3	0.0442	6	0.0074	0.4539	9	0.0504	0.7090	36	0.0197
.									
.									
.									
.									
1-8	0.1423	16	0.0089	0.9750	24	0.0406	1.9006	96	0.0198

Data for Lots 4 through 8 omitted to save space.

^A Where:

SS = sum of squares,
df = degrees of freedom, and
MS = mean square

TABLE A2.4 Sampling Specification FTRC 100, Lot Number ABC-123—ANOVA Table Revised

Source of Variance	Sum of Squares	Degrees of Freedom	Mean Squares	Mean Squares Composition
Lab Samples	1.1173	40	0.0279	$E + 3T$
Specimens	1.9006	96	0.0198	E
Total	3.0179	136		

TABLE A2.5 Variation and Cost of Several Sampling Plans^A

Plan	n	m	k	s	Cost, \$
1	1	1	1	0.150	9.63
2	1	3	10	0.039	113.13
3	1	4	5	0.041	79.13
4	1	5	4	0.039	80.13
5	1	7	2	0.042	61.13
6	1	8	2	0.040	69.13
7	2	2	2	0.056	56.26
8	2	3	3	0.039	79.26
9	3	2	3	0.039	84.39

^A Where:

n = number of lot sampling units,
 m = number of laboratory sampling units per lot sampling unit,
 k = number of specimens per laboratory sampling unit, and
 s = estimated standard deviation of the average produced by the sampling plan.

The American Society for Testing and Materials takes no position respecting the validity of any patent rights asserted in connection with any item mentioned in this standard. Users of this standard are expressly advised that determination of the validity of any such patent rights, and the risk of infringement of such rights, are entirely their own responsibility.

This standard is subject to revision at any time by the responsible technical committee and must be reviewed every five years and if not revised, either reapproved or withdrawn. Your comments are invited either for revision of this standard or for additional standards and should be addressed to ASTM Headquarters. Your comments will receive careful consideration at a meeting of the responsible technical committee, which you may attend. If you feel that your comments have not received a fair hearing you should make your views known to the ASTM Committee on Standards, at the address shown below.

This standard is copyrighted by ASTM, 100 Barr Harbor Drive, PO Box C700, West Conshohocken, PA 19428-2959, United States. Individual reprints (single or multiple copies) of this standard may be obtained by contacting ASTM at the above address or at 610-832-9585 (phone), 610-832-9555 (fax), or service@astm.org (e-mail); or through the ASTM website (www.astm.org).