



Standard Test Method for Impact Resistance of Plastic Sew-Through Flange Buttons¹

This standard is issued under the fixed designation D 5171; the number immediately following the designation indicates the year of original adoption or, in the case of revision, the year of last revision. A number in parentheses indicates the year of last reapproval. A superscript epsilon (ϵ) indicates an editorial change since the last revision or reapproval.

1. Scope

1.1 This test method covers the determination of impact resistance of plastic sew-through flange buttons.

1.2 The values stated in either acceptable metric units or other units shall be regarded separately as standard. The values expressed in each system may or may not be exact equivalents; therefore, each system must be used independently of the other, without combining values in any way.

1.3 *This standard does not purport to address all of the safety concerns, if any, associated with its use. It is the responsibility of the user of this standard to establish appropriate safety and health practices and determine the applicability of regulatory limitations prior to use.*

2. Referenced Documents

2.1 *ASTM Standards:*

D 123 Terminology Relating to Textiles²

D 618 Practice for Conditioning Plastics and Electrical Insulating Materials for Testing³

D 5497 Terminology Relating to Buttons⁴

3. Terminology

3.1 *Definitions:*

3.1.1 *button, n*—a knob, disc, or similar object which when forced through a narrow opening or buttonhole, fastens one part of a garment or other flexible substrate to another (See also sew-through flange button)

3.1.1.1 *Discussion*—Although the primary purpose of buttons is to serve as fasteners, buttons can also be used as decoration.

3.1.2 *face, n*—in buttons, that portion which will be exposed after attaching to the substrate.

3.1.3 *impact resistance, n*—resistance to fracture under the sudden application of an external force.

3.1.4 *ligne size, n*—a unit of measure for button diameter: one ligne equals 0.635 mm (0.025 in.)

3.1.5 *sew-through flange buttons, n*—a button that has two or more holes in its flange for passage of a needle and thread so that the button can be attached to a flexible substrate.

¹ This test method is under the jurisdiction of ASTM Committee D13 on Textiles and is the direct responsibility of Subcommittee D13.54 on Subassemblies.

Current edition approved April 10, 2000. Published July 2000. Originally published as D5171-91. Last previous edition D5171-99.

² *Annual Book of ASTM Standards*, Vol 07.01.

³ *Annual Book of ASTM Standards*, Vol 08.01.

⁴ *Annual Book of ASTM Standards*, Vol 07.02.

3.1.6 For other textile terminology used in this method, refer to Terminology D 123.

3.1.7 For definitions of button terms used in this method, refer to Terminology D 5497.

4. Summary of Test Method

4.1 Individual buttons are placed on a surface centered under a tube through which a preselected mass falls from a preselected height. After the mass impacts the button the impacted button is removed and visually examined using a 5X magnifying glass for breakage, cracking, or chipping.

5. Significance and Use

5.1 This test method may be used to determine the ability of a button to resist breaking under impact, for example in pressing the end item, which could cause the button to fail.

NOTE 1—In the development of this test method it was found that the following factors influenced the ability of a button to resist failure under impact conditions: resin formulation, shape ligne size, thickness, number and spacing of holes. Buttons may also pass this test but fail during the pressing of a garment due to the presence of heat during pressing.

5.1.1 If there are differences of practical significance between the reported test results for two laboratories (or more), comparative tests should be performed to determine if there is a statistical bias between them, using competent statistical assistance. As a minimum, test samples should be used that are as homogeneous as possible, that are drawn from the material from which the disparate test results were obtained, and that are randomly assigned in equal numbers to each laboratory for testing. Other materials with established test values may be used for this purpose. The test results from the two laboratories should be compared using a statistical test for unpaired data, at a probability level chosen prior to the testing series. If a bias is found, either its cause must be found and corrected, or future test results must be adjusted in consideration of the known bias.

5.2 Test Method D 5171 for the determination of the impact resistance of buttons may be used for acceptance testing of commercial shipments of buttons but caution is advisable since information is lacking on precision.

6. Apparatus

6.1 *Impact Resistance Testing Machine*—The impact resistance tester consists of a tube through which a plunger of standard mass drops onto the button from a predetermined

height. The button is centrally positioned based on ligne size, by means of a locating jig, on a flat metal surface. The energy of impact is determined by the mass of the plunger and the height of the drop.

6.2 *Magnifying Glass*—a 5X magnifying glass is used to visually examine the buttons after impact.

6.3 *Measuring Device*—measuring calipers or micrometer, to determine the ligne size of buttons.

7. Sampling

7.1 *Laboratory Sample*—As a laboratory sample, randomly select a quantity of buttons, approximately 100 to 200, from a

carton and from contained boxes, that adequately represents the material, from which test specimens may be selected.

7.2 *Test Specimens*—Randomly select 15 buttons from the laboratory sample for testing. If test specimens are submitted for preproduction approval, testing 1 dozen buttons is acceptable.

8. Conditioning

8.1 Condition the specimens as directed in Practice D 618 using procedure E. Following conditioning, prepare the specimens for testing as instructed in 9.4 of practice D 618. Preconditioning is not required.

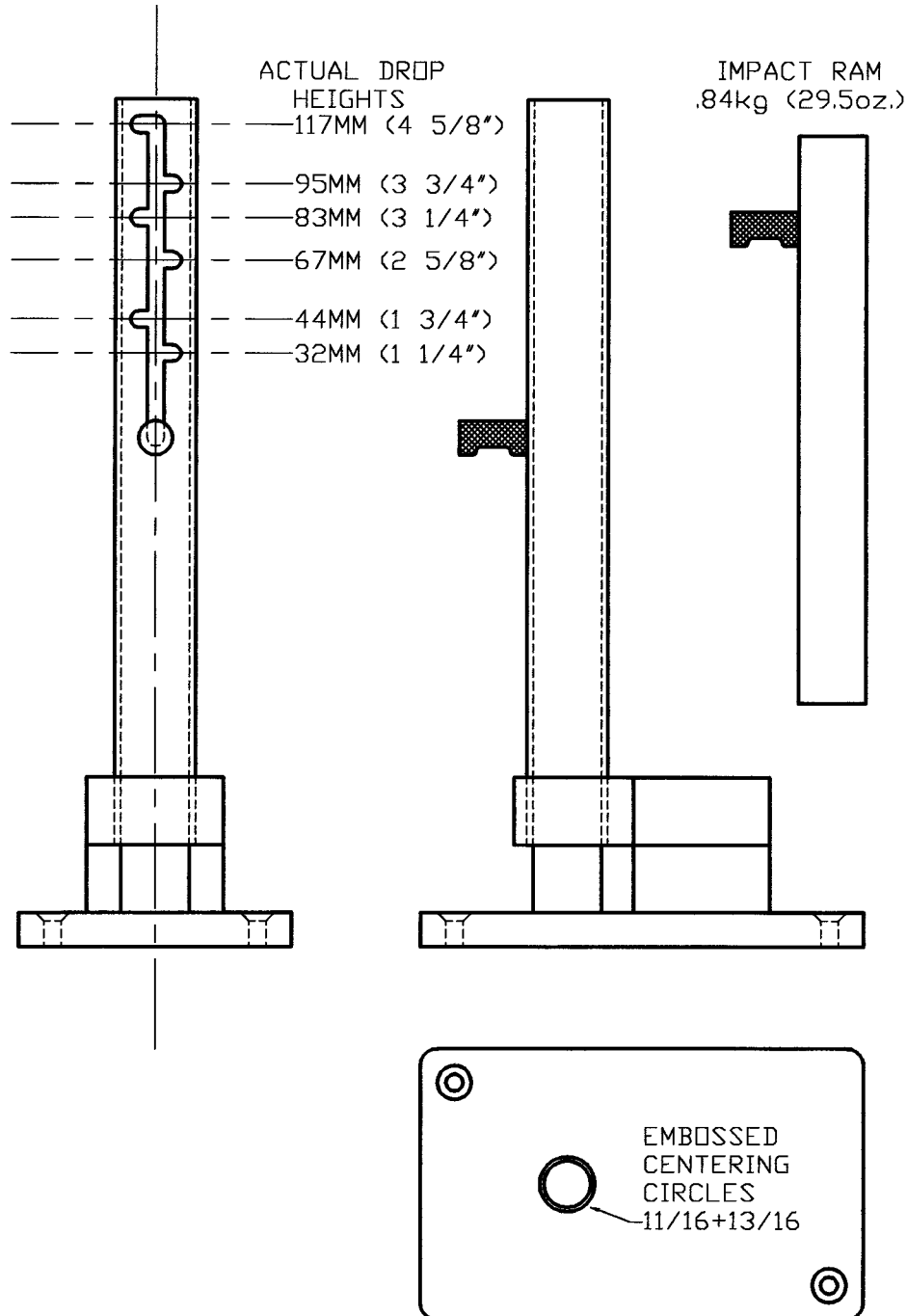

FIG. 1 Impact-Resistance Tester

9. Procedure

9.1 *Determine Button Ligne Size*—Using a set of calipers or a micrometer slowly bring the instrument faces or anvils into contact with the button to obtain the button diameter. Divide the measured diameter in mm (in) by the constant 0.635 mm (0.025 in.) and record to the nearest whole number as the ligne size.

9.2 *Determine Impact Resistance*—Place specimen in centering device for ligne size of button so it lies at the center of the vertical tube. Allow the mass to fall from a predetermined and reproducible height onto the button. Lift the mass and remove the specimen from the metal base.

10. Evaluation

10.1 Visually examine the tested specimens with a 5X magnifying glass for cracking, chipping, and breakage, any of which constitutes damage. Test the remaining specimens.

11. Report

11.1 State that the specimens were tested as directed in Test Method D 5171. Describe the material or product sampled.

11.1.1 Total number of specimens,

11.1.2 Button ligne size,

11.1.3 Height of fall and mass of plunger, if the standard conditions are not used.

11.1.4 Number of specimens damaged due to (1) cracking, (2) chipping (3) breakage.

12. Precision and Bias

12.1 No information is presented about either the precision or bias of this test method since the test result is nonquantitative.

12.2 *Bias*—No justifiable statement can be made on the bias of Test Method D 5171 for testing the impact resistance of buttons since the true value cannot be established by an accepted referee method.

13. Keywords

13.1 button; impact resistance; strength

The American Society for Testing and Materials takes no position respecting the validity of any patent rights asserted in connection with any item mentioned in this standard. Users of this standard are expressly advised that determination of the validity of any such patent rights, and the risk of infringement of such rights, are entirely their own responsibility.

This standard is subject to revision at any time by the responsible technical committee and must be reviewed every five years and if not revised, either reapproved or withdrawn. Your comments are invited either for revision of this standard or for additional standards and should be addressed to ASTM Headquarters. Your comments will receive careful consideration at a meeting of the responsible technical committee, which you may attend. If you feel that your comments have not received a fair hearing you should make your views known to the ASTM Committee on Standards, at the address shown below.

This standard is copyrighted by ASTM, 100 Barr Harbor Drive, PO Box C700, West Conshohocken, PA 19428-2959, United States. Individual reprints (single or multiple copies) of this standard may be obtained by contacting ASTM at the above address or at 610-832-9585 (phone), 610-832-9555 (fax), or service@astm.org (e-mail); or through the ASTM website (www.astm.org).