



Standard Test Method for Determining the Edgcomb Resistance of Woven Fabrics Used in Inflatable Restraints¹

This standard is issued under the fixed designation D 6479; the number immediately following the designation indicates the year of original adoption or, in the case of revision, the year of last revision. A number in parentheses indicates the year of last reapproval. A superscript epsilon (ϵ) indicates an editorial change since the last revision or reapproval.

1. Scope

1.1 This test method covers the procedures for determining the resistance to edgcombing of a woven fabric used in inflatable restraints.

1.2 Procedures and apparatus other than those stated in this standard may be used by agreement of purchaser and supplier with the specific deviations from the standard practice acknowledged in the report.

1.3 The values stated in either SI units or inch-pound units are to be regarded separately as standard. The values stated in each system are not exact equivalents; therefore, each system must be used independent of the other.

1.4 *This standard does not purport to address all of the safety concerns, if any, associated with its use. It is the responsibility of the user of this standard to establish appropriate safety and health practices and determine the applicability of regulatory limitations prior to use.*

2. Referenced Documents

2.1 ASTM Standards:

- D 76 Specification for Tensile Testing Machines for Textiles²
- D 123 Terminology Relating to Textiles²
- D 1776 Practice for Conditioning Textiles for Testing²
- D 2904 Practice for Interlaboratory Testing of a Textile Test Method that Produces Normally Distributed Data²
- D 2906 Practice for Statements on Precision and Bias for Textiles²
- D 5035 Test Method for Breaking Force and Elongation of Textile Fabrics (Raveled Strip)³
- D 5822 (Test Method for Determining Seam Strength in Inflatable Restraint Cushion)³
- D 6799 Terminology Relating to Inflatable Restraints⁴
- E 691 Practice for Conducting an Interlaboratory Study to Determine The Precision of a Test Method²

3. Terminology

3.1 Definitions:

3.2 For definitions of other terms used in this standard, refer to Terminology D 123 and Terminology D 6799.

4. Summary of Test Method

4.1 One end of a test specimen is clamped within one jaw of a CRE tensile testing machine and a special fixture pierces a row of equally spaced needle holes through the opposite end of the specimen. In accordance with Test Method D 5035, a tensile force is applied to the specimen until rupture occurs. The measurement of the force required to cause rupture is the measurement of edgcomb resistance.

5. Significance and Use

5.1 A measurement of a fabric's edgcomb resistance indicates the relative tendency of a fabric to pull apart under seam stress or similar action. The related concepts of yarn slippage and seam slippage are limited to sewn seams, whereas the measurement of edgcomb resistance is made at the edge of a cut part in the absence of a sewn seam. The absence of a sewn seam in this test method eliminates the effect that a particular stitch might have on the tendency of a yarn to slip near an edge of a cut part

5.2 This test method is useful for material design evaluations in such applications as airbags in which seam stress is a major concern.

5.3 This method may be used as a complement to Test Method D 5822.

6. Apparatus

6.1 *Tensile Testing Machine*—A constant-rate-of-extension (CRE) type, that is designed for the tensile forces anticipated, that is operated at a rate of 200 ± 10 mm/min (8 ± 0.5 in./min), that has a force range selected such that the anticipated break occurs between 10 and 90 % of full scale load, and that has jaws and grip faces as agreed upon by purchaser and supplier.

6.2 *Clamps*, jaws with smooth, flat, parallel faces a minimum of 60 mm wide by 25 mm tall. The jaws may be padded or coated under the jaw face area.

6.3 *Fixture*, compatible with tensile tester, equipped with twelve equally spaced 1 mm diameter pins, 8 mm in length and

¹ This test method is under the jurisdiction of ASTM Committee D13 on Textiles and are the direct responsibility of Subcommittee D13.20 on Inflatable Restraints.

Current edition approved April 10, 2002. Published June 2002. Originally published as D 6479–99. Last previous edition D 6479 – 01.

² *Annual Book of ASTM Standards*, Vol 07.01.

³ *Annual Book of ASTM Standards*, Vol 07.02.

⁴ *Annual Book of ASTM Standards*, Vol 07.02.

corresponding 1.5 mm diameter holes with a stop located 5 mm from the center of the holes (Fig. 1).

6.4 *Load Cell*, whose rated capacity is between 110 and 1000 % of expected stripping load. A 2000 N load cell is generally used for inflatable restraints.

6.5 For inflatable restraints, all test equipment used in accordance with this test method shall be certified for calibration annually by an independent agency or equipment manufacturer whose results are traceable to National Institute of Science and Technology (NIST) or other national standards laboratory. The test parameters of the equipment shall be tested within the operating ranges covered in the cushion specification or equivalent document.

7. Sampling and Specimen Preparation

7.1 Edgecomb resistance testing is a destructive test. If used in conjunction with lot testing, sampling is required.

7.2 For acceptance testing the lot size is the number of rolls of fabric produced in one production day, or as specified in the applicable material specification.

7.3 From the end of each roll of fabric taken from the lot sample, cut a 1 m long, full width sample of fabric.

7.4 From the laboratory sample, select five test specimens each from the warp and fill directions (Fig. 2).

7.5 Without sealing or unraveling the edges, cut each specimen 50 ± 1 mm wide and 300 ± 5 mm long, with the long dimension parallel to the warp yarns for a warp-oriented test, and parallel to the fill yarns for a fill-oriented test.

8. Conditioning

8.1 Specimens for edgecomb resistance testing shall be conditioned at the standard atmosphere for testing textiles for at least 4 h prior to test in accordance with Test Method D 1276.

9. Procedure

9.1 Prepare the tensile testing machine in accordance with Test Method D 5035.

9.2 Set the gage length between clamps at 200 ± 1 mm (4 ± 0.1 in).

9.3 Select the force range of the testing machine for the break to occur between 10 and 90 % of full-scale force. Calibrate or verify the testing machine for this range.

9.4 Set the testing machine for a loading rate of 200 ± 10 mm/min (8 ± 0.5 in./min).

9.5 Ensure proper clamping as directed by Test Method D 5035.

9.6 Mount one end of the specimen into the bottom clamp position of the edgecomb fixture, ensuring that the end of the specimen abuts flatly and evenly against the alignment block, parallel to and behind the pinholes.

9.7 Pierce the end of the specimen with the 12 1.0 mm pins and secure the hinge.

9.8 Mount the opposite end of the specimen securely in the opposite clamp of the testing machine in accordance with Test Method D 5035. Ensure that the specimen is not pulled and the yarns displaced.

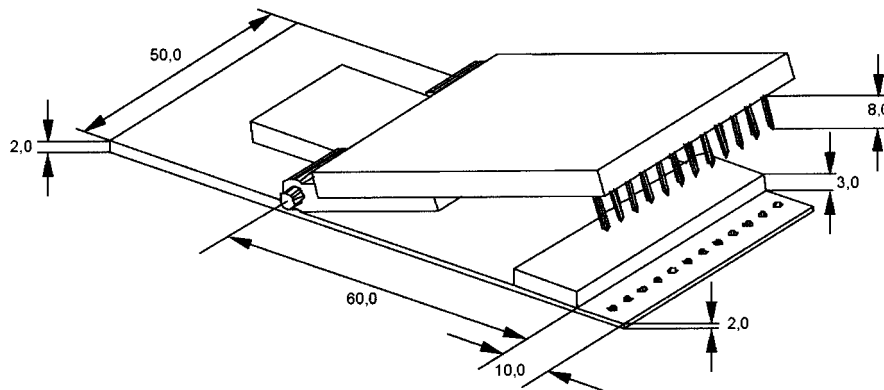

- Description:
- 50,0 mm total width for baseplate of the specimens holder
 - 70,0 mm total length for moveable arm of the specimens holder
 - 3,0 mm distance from centre of the first needle to edge of specimens holder
 - 4,0 mm distance between centres of the needles
 - 1,0 mm diameter of needles
 - 12 grounded needles
 - 8,0 mm length of visible needles
 - 10,0 mm total lock distance for specimens
 - 5,0 mm distance between centre of drillings to edge of specimen holder
 - 1,5 mm diameter of drillings at the base plate
 - Connection between specimens holder and testing device to be fitted due to the needs of the testing device

FIG. 1 Fixture

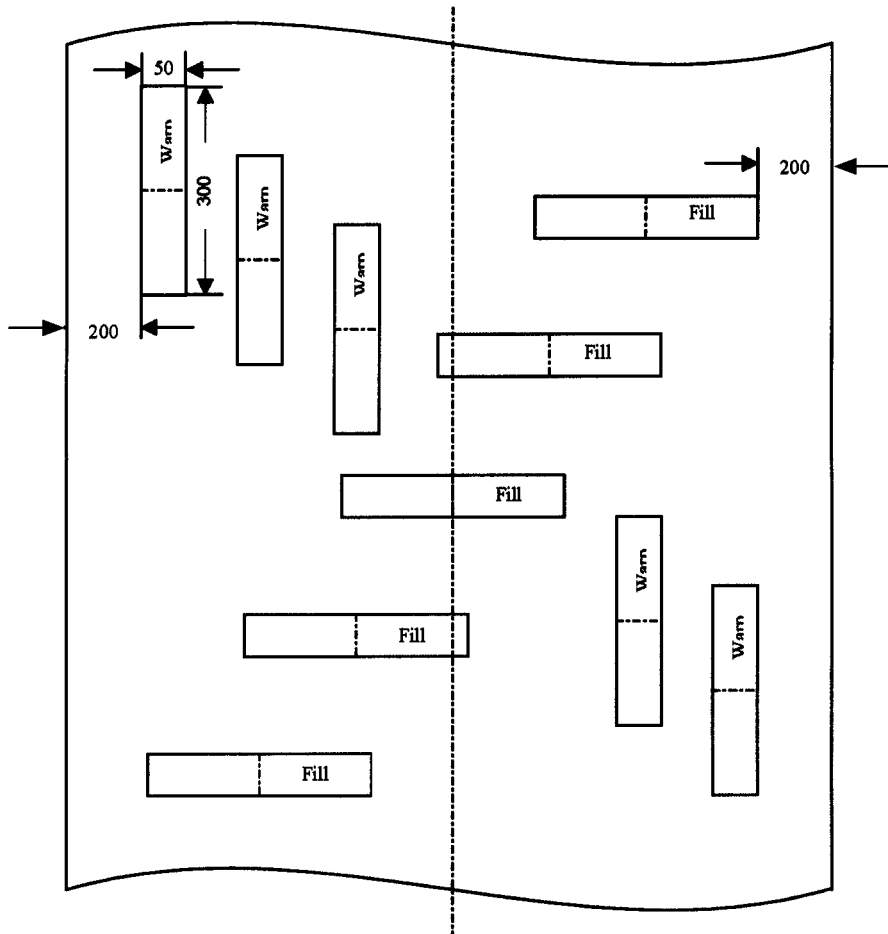

FIG. 2 Test Specimens

9.9 Operate the machine and break the specimen in accordance with Test Method D 5035.

9.10 Record the breaking force separately for both the warp and fill directions. Determine the median of the break forces observed for all specimens tested.

10. Report

10.1 State that the tests were conducted in accordance with this test method.

10.2 If deviation from this test method occurred, any reference to this standard shall state: "Testing was performed in accordance with ASTM D 6479, with the following changes:"

10.3 The purchaser and supplier shall determine the exact form of the test report. Unless otherwise specified, the form shall provide the following information:

- 10.3.1 Lot identification,
- 10.3.2 Date of report,
- 10.3.3 Name of person certifying report,

- 10.3.4 Relevant specification,
- 10.3.5 Number of specimens used in each test
- 10.3.6 Tests performed and data obtained,
- 10.3.7 Laboratory conditions if other than standard, and
- 10.3.8 Deviations from standard procedures and apparatus.

11. Precision and Bias

11.1 An interlaboratory test was conducted in accordance with Practice D 2904 and Practice E 691 using TexPac.⁵ A precision and bias statement based on the interlaboratory report is being developed in accordance with Practice D 2906.

12. Keywords

12.1 airbag; break force; edgecomb resistance; inflatable restraint

⁵ TEX-PAC is available from ASTM Headquarters. Request ADJD2904.



D 6479

ASTM International takes no position respecting the validity of any patent rights asserted in connection with any item mentioned in this standard. Users of this standard are expressly advised that determination of the validity of any such patent rights, and the risk of infringement of such rights, are entirely their own responsibility.

This standard is subject to revision at any time by the responsible technical committee and must be reviewed every five years and if not revised, either reapproved or withdrawn. Your comments are invited either for revision of this standard or for additional standards and should be addressed to ASTM International Headquarters. Your comments will receive careful consideration at a meeting of the responsible technical committee, which you may attend. If you feel that your comments have not received a fair hearing you should make your views known to the ASTM Committee on Standards, at the address shown below.

This standard is copyrighted by ASTM International, 100 Barr Harbor Drive, PO Box C700, West Conshohocken, PA 19428-2959, United States. Individual reprints (single or multiple copies) of this standard may be obtained by contacting ASTM at the above address or at 610-832-9585 (phone), 610-832-9555 (fax), or service@astm.org (e-mail); or through the ASTM website (www.astm.org).