



Standard Test Method for Flammability of Textiles Used in Children's Sleepwear¹

This standard is issued under the fixed designation D 6545; the number immediately following the designation indicates the year of original adoption or, in the case of revision, the year of last revision. A number in parentheses indicates the year of last reapproval. A superscript epsilon (ϵ) indicates an editorial change since the last revision or reapproval.

1. Scope

1.1 This test method evaluates the relative flammability of textiles and garments intended for use in children's sleepwear. The procedures of this test method follow testing and laundering procedures used to evaluate the flammability of children's sleepwear contained in US Federal Regulations 16 CFR 1615 and 1616.²

1.2 A textile used in children's sleepwear must be tested in its original state and after 50 laundering and drying cycles to assess the flame resistance of the textile relative to its use life.

1.3 The values stated in SI units are to be regarded as the standard; inch-pound units are provided for information only.

1.4 *This test method should be used to measure and describe the properties of materials, products, or assemblies in response to heat and flame under controlled laboratory conditions and should not be used to describe or appraise the fire hazard or fire risk of materials, products, or assemblies under actual fire conditions. However, the test results may be used as elements of a fire-risk assessment, which takes into account all of the factors, which are pertinent factors to the potential fire hazard of a particular end use.*

1.5 *This standard does not purport to address all of the safety concerns, if any, associated with its use. It is the responsibility of the user of this standard to establish appropriate safety and health practices and determines the applicability of regulatory limitations prior to use.* Specific precautionary information is found in 8.5 and 9.5.

2. Referenced Documents

2.1 ASTM Standards:

D 123 Terminology Relating to Textiles³

2.2 AATCC Test Method

Glossary of AATCC Standard Terminology⁴

AATCC Test Method 124 - 1969 Appearance of Durable Press Fabrics After Repeated Home Laundering⁴

2.3 Federal Standards and Regulations:

16 CFR Part 1610 Standard for the Flammability of Vinyl Plastic Film⁵

16 CFR Part 1611 Standard for the Flammability of Clothing Textiles⁵

16 CFR Part 1615 Standard for the Flammability of Children's Sleepwear: Sizes 0 through 6X⁵

16 CFR Part 1616 Standard for the Flammability of Children's Sleepwear: Sizes 7 through 14⁵

Department of Commerce Voluntary Product Standard, previously identified as Commercial Standard, CS 151-50 "Body Measurements for the Sizing of Apparel for Infants, Babies, Toddlers, and Children"⁶

3. Terminology

3.1 Definitions:

3.1.1 *char length, n*—the distance from the original lower edge of the specimen exposed to the flame to the end of the tear or void in the charred, burned, or damaged area.

3.1.2 *children's sleepwear, n*—any product of wearing apparel such as nightgowns, pajamas, or similar or related items, such as robes, intended to be worn primarily for sleeping or activities related to sleeping.

3.1.2.1 *Discussion*—While children's sleepwear can include a range of configurations, these do not include diapers and underwear, infant garments, and tight-fitting garments, as defined by 16 CFR 1615 and 1616. The size range of these garments is limited to those defined in 16 CFR 1615 and 1616 and the Department of Commerce/Commercial Standard 151-50 reference provides background information on how these size ranges were selected and how the body measurements were conducted.

3.1.3 *fabric piece (piece), n*—a continuous, unseamed length of fabric, one or more of which make up a fabric production unit.

3.1.4 *fabric production unit (unit), n*—any quantity of finished fabric pieces which have a specific identify that remains unchanged except for color or print pattern.

3.1.4.1 *Discussion*—This fabric production unit, as specified in 16 CFR 1615, and 1616 can consist of quantities from 5 000 linear yards for normal sampling or up to 10 000 linear yards for reduced sampling. Finished fabrics are those fabric

¹ This test method is under the jurisdiction of ASTM Committee D-13 on Textiles and is the direct responsibility of Subcommittee D13.52 on Flammability. Current edition approved Nov. 10, 2000. Published November 2000.

² This test method is not identical to 16 CFR Parts 1615 and 1616 and should not be used in place of the CPSC standards.

³ *Annual Book of ASTM Standards*, Vol 07.01.

⁴ Available from the American Association of Textile Chemists and Colorists, P.O. Box 12215, Research Triangle Park, NC 27709. Reference from the 1970 edition of the manual.

⁵ Available from U.S. Government Printing Office, Superintendent of Documents, Mail Stop SSOP, Washington, DC 20402-9328.

⁶ Available from the National Technical Information Service, 5285 Port Royal Street, Springfield, VA 22151, order CS 15150.

pieces which have undergone all processes prior to being cut or slit into components to be manufactured into children's sleepwear.

3.1.5 *flame retardant, n*—a chemical used to impart flame resistance.

3.1.6 *flame retardant treated, adj*—having received a flame-retardant treatment.

3.1.6.1 *Discussion*—The term “flame retardant treated” does not apply to textiles that are inherently flame resistant due to the intrinsic properties of the material or the fiber-forming polymer.

3.1.7 *flammability, n*—those characteristics of a material that pertain to its relative ease of ignition and relative ability to sustain combustion.

3.1.8 *flammable textile, n*—any combustible textile that burns with a flame.

3.1.9 *garment production unit (unit), n*—any quantity of finished garments which has a specific identity that remains unchanged throughout the unit except for size, trim, findings, color, and print patterns.

3.1.9.1 *Discussion*—As specified in 16 CFR 1615 and 1616, a garment production unit is normally any quantity up to 500 dozen.

3.1.10 *infant garment, n*—a garment, which is, sized nine months or smaller.

3.1.10.1 *Discussion*—An infant garment may be either a one-piece garment (which does not exceed 64.8 cm [25.75 in.] in length) or a two-piece garment (no piece exceeding 40 cm [15.75 in.] in length); and complies with all applicable requirements of the 16 CFR Part 1610 and 16 CFR part 1611; and bears a label stating the size of the garment expressed as age in months.

3.1.11 *item, n*—a single article or unit.

3.1.11.1 *Discussion*—In this test method, item refers to any article of children's sleepwear or fabric or related material intended or promoted for use in children's sleepwear.

3.2 For definitions of other terms used in this test method refer to Terminology D 123 and to the *Glossary of AATCC Standard Terminology*.

4. Summary of Test Method

4.1 This test method evaluates the extent of vertical flame spread of a textile after a flame is applied to the bottom edge of the specimen. The specimen is oriented vertically during the test and is exposed to a 38-mm (1.5-in.) flame for 3 s.

4.2 The extent of flame spread is determined by measuring the distance from the lower edge of the specimen to the point at which the specimen ceases to tear when subjected to a specified tearing load.

5. Significance and Use

5.1 This test method is suitable for evaluating flammability characteristics and laundering durability of textiles used in the manufacture of children's sleepwear. It is not suitable for evaluating the flammability characteristics of textiles for other product applications or ignition scenarios.

5.2 The procedure for flammability testing used in this test method is technically equivalent to those used in 16 CFR 1615 and 1616. The laundering requirements vary slightly because

the detergent that is cited in the AATCC Test Method 124-69 is no longer commercially available. This test method does not include detailed specimen sampling plans, or the regulatory and record keeping requirements cited in the federal regulations. Please consult 16 CFR 1615 and 1616 for information for these operations.

5.3 This test method is suitable for training technicians to conduct the federal test and can serve as a laboratory reference.

5.4 In the future, if the U.S. Consumer Product Safety Commission updates the federal regulations to revise the textile refurbishing methods to those in current industry use, this test method will be revised to reflect those changes.

6. Apparatus and Materials

6.1 *Test Chamber*—The test chamber shall be constructed of a steel or stainless steel cabinet with inside dimensions of 32.9 ± 0.15 cm (12.94 ± 0.06 in.) wide, 32.9 ± 0.15 cm (12.94 ± 0.06 in.) deep, and 76.2 ± 0.15 cm (30 ± 0.06 in.) high. The cabinet shall have a frame, perpendicular to the front of the cabinet, which permits the suspension of the specimen holder over the center of the base of the cabinet at such a height that the bottom of the specimen holder is 1.9 ± 0.15 cm (0.75 ± 0.06 in.) above the highest point of the barrel of the gas burner. The front of the cabinet shall be a close-fitting door with a glass insert to permit observation of the entire test. The inside rear vertical surface of the cabinet may be painted flat black to improve visibility of the burning specimen during the test. The cabinet floor may be covered with a piece of noncombustible paper, fabric, or film whose length and width are approximately 2.5 cm (1 in.) less than the cabinet floor dimensions. The cabinet to be used in this test method is illustrated in Fig. 1 and detailed in Figs. 1-4. A suitable flame height indicator is shown in Fig. 5.

6.2 *Specimen Holder, n*—The specimen holder is designed to permit suspension of the specimen in a fixed vertical position and to prevent curling of the specimen when the flame is applied. It shall consist of two U-shaped 0.19 cm (0.074 in.; 14-gage USS) thick steel or stainless steel plates, 42.2 ± 0.15 cm (16.62 ± 0.06 in.) long, and 8.9 ± 0.15 cm (3.5 ± 0.06 in.) wide, with aligning pins. The openings in the plates shall be 35.6 cm (14 ± 0.06 in.) long and 5.1 ± 0.15 cm (2 ± 0.06 in.) wide. The specimen shall be fixed between the plates, which shall be held together with side clamps. The holder to be used in this test method is illustrated in Fig. 6.

6.3 *Burner, n*—The burner shall be substantially the same as that illustrated in Figs. 7 and 8. The burner shall have the inside tube diameter of 1.1 cm (0.437 in.). The input line to the burner shall be equipped with a needle valve to provide a variable orifice to adjust the height of the flame. The barrel of the burner shall be at an angle of 25° from the vertical. The burner shall be equipped with an adjustable stop collar so that it may be quickly located correctly under the test specimen. The burner shall be connected to the gas source by rubber or other flexible tubing.

6.4 *Gas Supply System, n*—there shall be a pressure regulator to furnish gas to the burner under a pressure of 129 ± 13 mm Hg ($2\frac{1}{2} \pm \frac{1}{4}$ lb/in.²) at the burner inlet.

6.5 *Gas, n*—The gas shall be at least 97 % pure methane.

6.6 *Hooks and Weights, n*—Metal hooks and weights shall

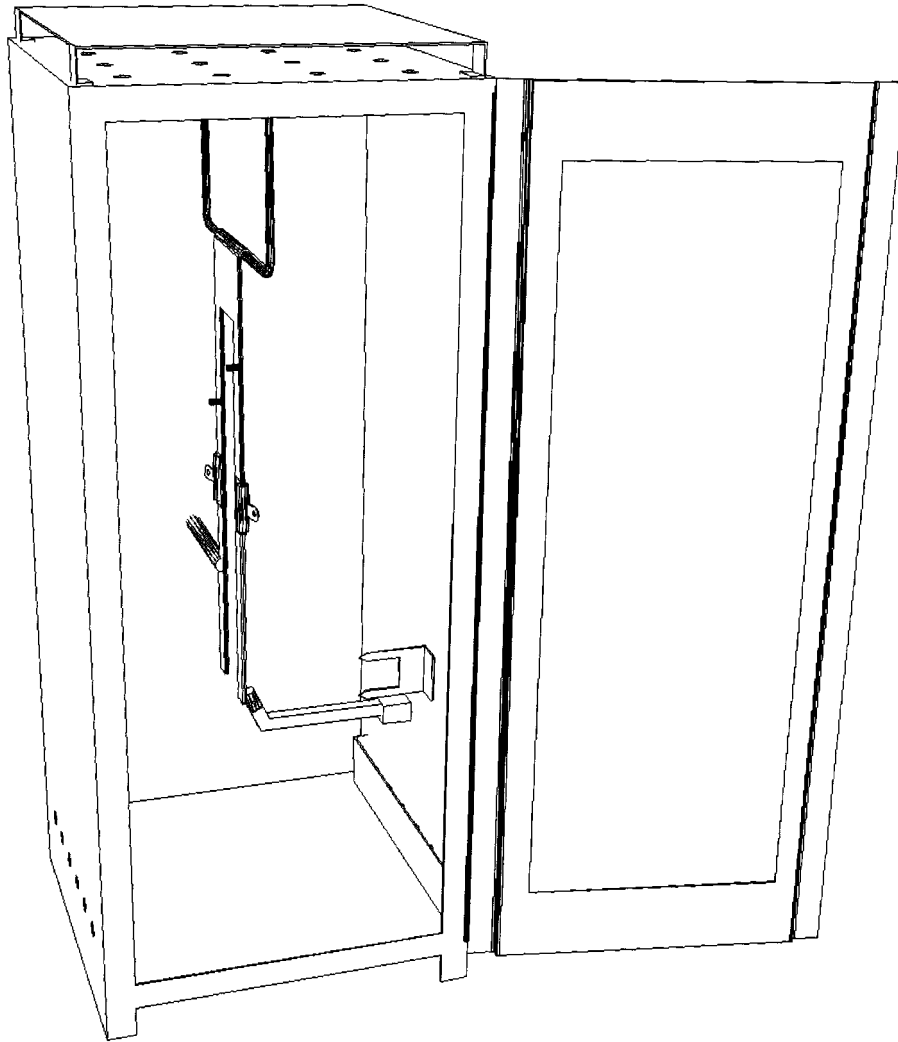

FIG. 1 Test Apparatus

be used to produce a series of loads for char length determinations. Suitable metal hooks consist of 1.1-mm (0.043-in.; No. 19 gage) diameter steel or stainless steel wire, or equivalent, made from 7.6-cm (3-in.) lengths of the wire, bent 1.3 cm (0.5 in.) from one end to a 45° angle hook. The longer end of the wire is fastened around the neck of the weight to be used and the other in the lower end of each burned specimen to one side of the burned area. The requisite loads are given in Table 1.

6.7 *Stopwatch*—A stopwatch or similar timing device shall be used to measure time to 0.1 s.

6.8 *Scale*—A linear scale graduated in millimetres or 0.1-in. divisions shall be used to measure char length.

6.9 *Circulating Air Oven*—A forced-circulation drying oven capable of maintaining the specimens at $105 \pm 2.8^\circ\text{C}$ ($221 \pm 5^\circ\text{F}$), shall be used to dry the specimen while mounted in the specimen holders.

6.10 *Desiccator*—An airtight and moisture-tight desiccating chamber shall be used for cooling mounted specimens after drying. Anhydrous silica gel shall be used as the desiccant.

6.11 *Hood*—A hood or other suitable enclosure shall be used to provide a draft-free environment surrounding the test

chamber. This enclosure shall have a fan or other suitable means for exhausting smoke or toxic gases, or both, produced by testing.

7. Test Specimens and Sampling

7.1 *Test Specimen*—A section of fabric measuring 8.9 by 25.4 cm (3.5 by 10 in.). For prototype seam, prototype trim, and production garment testing, the specimen will include a seam or trim.

7.2 *Sample*—Five test specimens cut from the appropriate fabric pieces, prototype seams or trims, or production garments, in accordance with the sampling plan in 16 CFR 1615 or 1616.

7.3 Test specimens shall be cut to a length of 254 ± 3 mm (10 ± 0.1 in.) and a width of 89 ± 3 mm (3.5 ± 0.1 in.).

7.4 Two or three specimens shall be cut with their long dimension in the machine direction and three or two shall be cut with their long dimension in the cross-machine direction. Each group of five specimens then constitutes one sample. Individual determinations for each specimen, and the average of the sample set constitute the test result.

7.5 Fabrics used in the manufacture of children's sleepwear

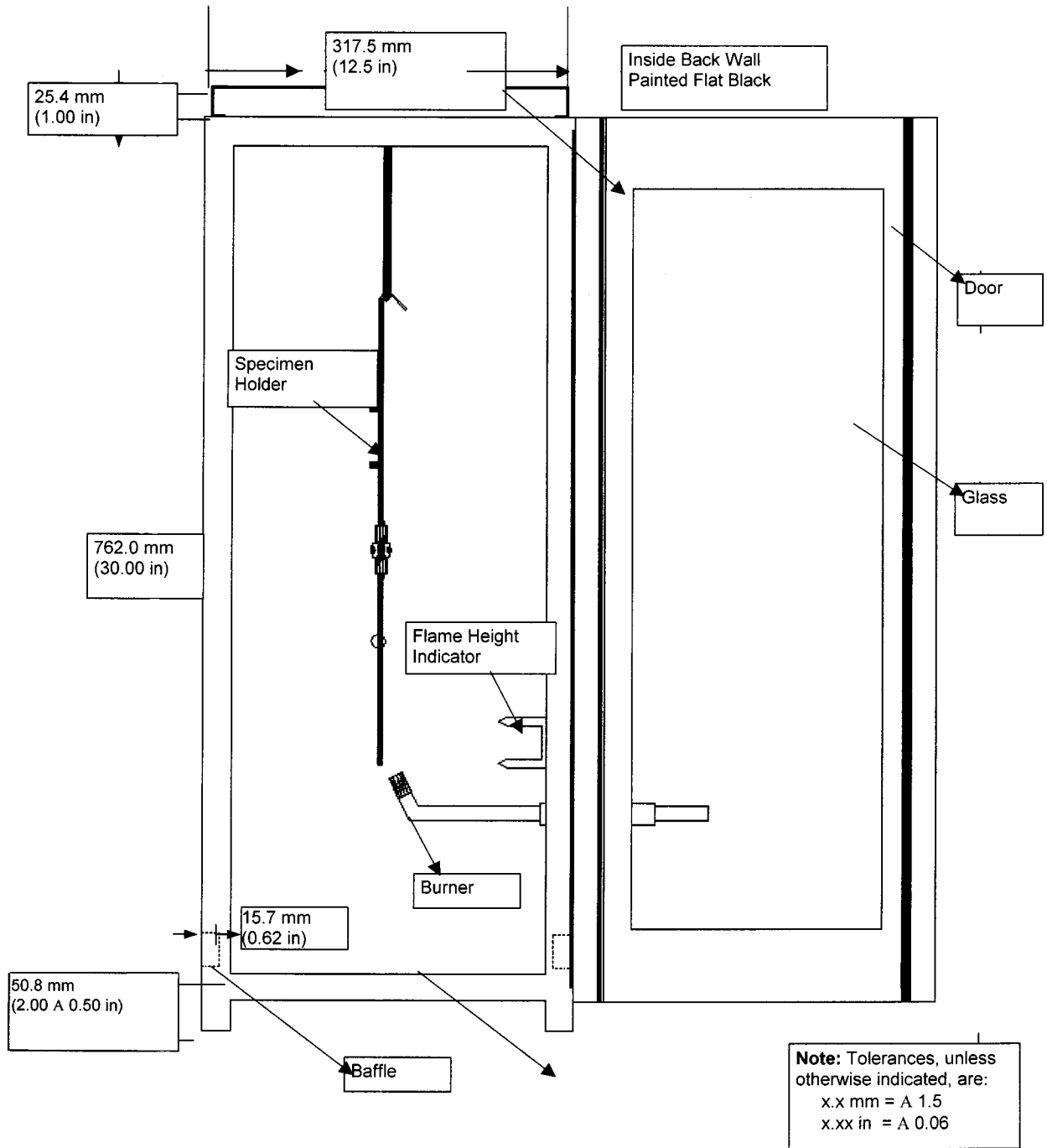

FIG. 2 Front View

shall be tested after the final stage of production and after the fabric has been laundered 50 times in accordance with the procedure in Section 10. Fabrics that have not been treated to be made flame-resistant, and where there will be multiple production runs of this fabric type, are not required to be tested after 50 launderings; provided that the first fabric production unit has met the flammability requirements of the federal standard both as produced and after 50 launderings.

7.6 Sampling of fabrics and garments for compliance to the federal regulation is not part of this test method. Refer to 16 CFR 1615 and 1616 for instructions on compliance sampling.

8. Preconditioning and Conditioning

8.1 Precondition all specimens at $20 \pm 2^\circ\text{C}$ ($68 \pm 4^\circ\text{F}$) for a minimum of 4 h before conditioning.

8.2 After preconditioning, mount each specimen in a specimen holder using a sufficient number of clamps or tape to ensure that the specimen cannot move within the specimen holder. Ensure that the specimen is as flat as is practical.

8.3 Condition each specimen in a circulating oven at a temperature of $105 \pm 2^\circ\text{C}$ ($221 \pm 4^\circ\text{F}$) for 30 min.

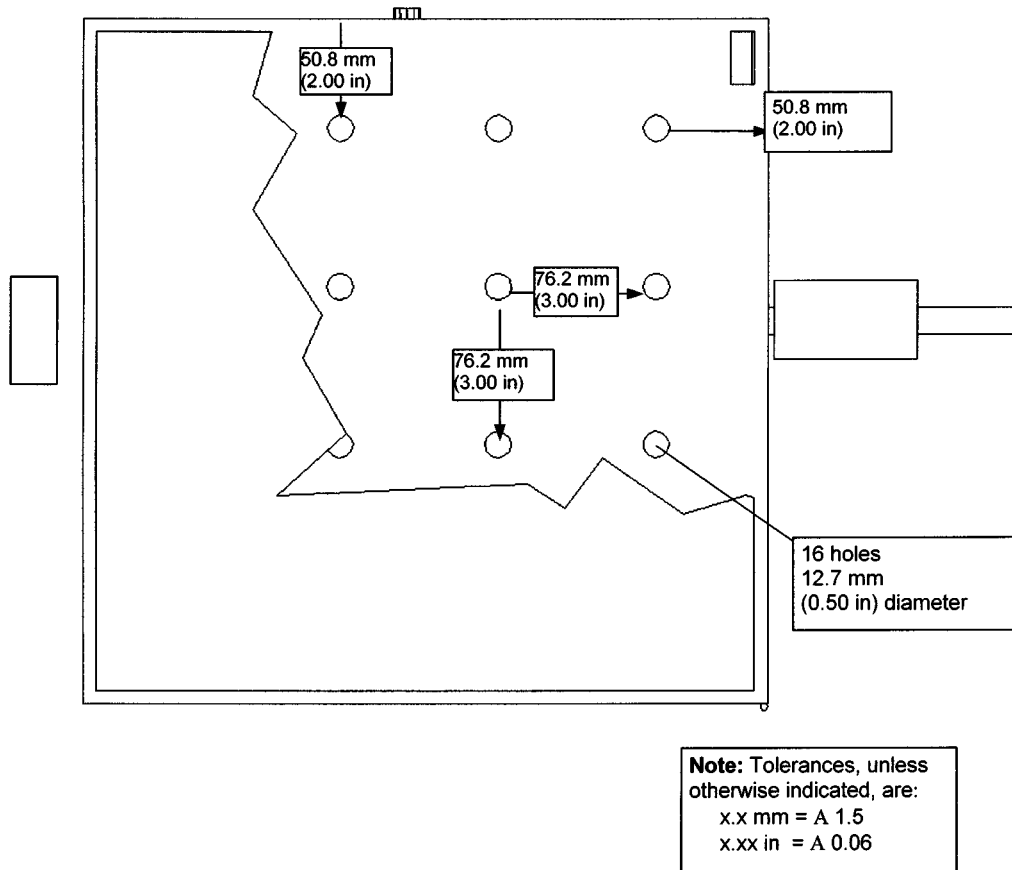

FIG. 3 Top View

8.4 Remove the conditioned specimens from the conditioning oven and place them in the desiccator to cool for at least 30 minutes but not over 60 minutes. No more than five (5) specimens shall be placed in a desiccator at one time.

8.5 Handle the hot specimen holders with caution as they are placed into and removed from the conditioning oven. Use suitable gloves or tongs.

9. Procedure

9.1 With the hood fan turned off, turn on the gas supply and adjust the needle valve on the burner to obtain a flame height of approximately 38 mm (1.5 in.). Allow the burner to operate with the test cabinet door closed for at least 5 min. Upon completion of this operation, dim the room lights and adjust the flame height so that the distance from the uppermost edge of the burner to the tip of the visible portion of the flame is 38 ± 2 mm (1.5 ± 0.1 in.). The flame height indicator shown in Fig. 6 has been found suitable for this purpose.

9.2 Remove a mounted specimen from the desiccator and place it on the interior test cabinet hanger and close the door. Move the flame into place so that the bottom edge of the specimen is located directly above the midpoint of the flame.

9.3 Ignite the specimen within 30 s of removing it from the desiccator. After the specimen has been exposed to the igniting flame for $3.0 + 0.2$ s, pull the burner aside to terminate the exposure.

9.4 When all after flame and afterglow have extinguished, operate the hood fan for sufficient time to remove all combus-

tion gases from the test cabinet and hood area. Also, be aware that fumes and combustion products in the test cabinet are noxious and may even be toxic. Avoid inhaling these fumes or use appropriate breathing apparatus.

9.5 Remove the specimen holder from the test cabinet. Use caution when handling the specimen holder and test specimen as these articles may be hot to the touch.

9.6 Remove the specimen from the holder and crease it along a line through the highest peak of the charred or damaged area.

9.7 Unfold the specimen and insert one hook with the correct weight, as shown in Table 1, in the specimen on one side of the charred area 6.4 ± 2.0 mm (0.25 ± 0.1 in.) from the lower edge.

9.8 Gently lift the other corner of the specimen without the weight until the weight supported by the other hook is lifted above the work surface. This procedure causes the highly damaged areas to tear to the point that they will sustain the prescribed tensile load.

9.9 Using the scale, measure the char length as the distance from the end of the tear edge to the edge of the specimen exposed to the flame (see Fig. 9). Record this length on the test report.

9.10 Repeat 9.2-9.9 until the five specimens have been tested.

9.11 *Test Criteria*—The average of the char length values obtained for the five specimens and the maximum char lengths

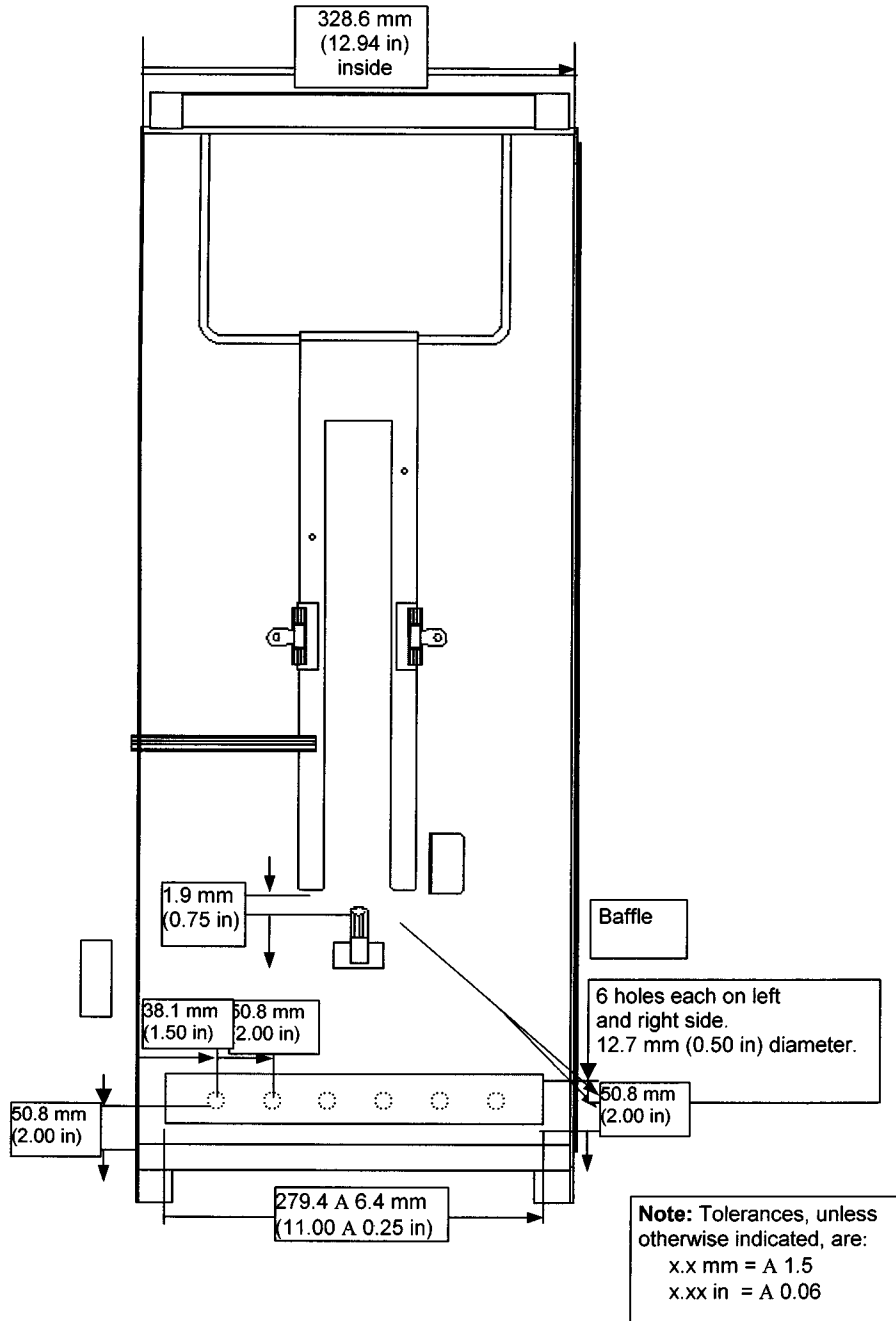

FIG. 4 Left-Side View (Left-Side Panel Removed)

for the individual specimens constitutes the test results.

10. Laundering

10.1 Launder and dry all sample fabrics through 50 complete laundering and drying cycles using the procedure specified in AATCC Test Method 124 - 1996 as described in the 1997 Technical Manual, Sections 8.2.2, 8.2.3, and 8.3.1(A).

10.1.1 Washing shall be performed in accordance with sections 8.2.2 and 8.2.3 of AATCC Test Method 124-1996, using wash temperature V ($60 \pm 3^\circ\text{C}$, $140 \pm 5^\circ\text{F}$) specified in Table II of that method, and the water level, agitator speed, washing time, spin speed and final spin cycled specified for "Normal/Cotton Sturdy" in Table III. A maximum washer load

shall be 3.64 Kg (8lb) and may consist of any combination of test samples and dummy pieces. Drying shall be performed in accordance with section 8.3.1 (A) of that test method, Tumble Dry, using exhaust temperature ($66 \pm 5^\circ\text{C}$, $150 \pm 10^\circ\text{F}$) and cool down time of 10 min specified in the "Durable Press" conditions of Table IV.

10.2 From the laundered sample fabrics, cut, prepare, precondition, and condition the test specimens, in accordance with 9.2-9.10.

11. Report

11.1 Report the following information:

11.1.1 Date and time of test.

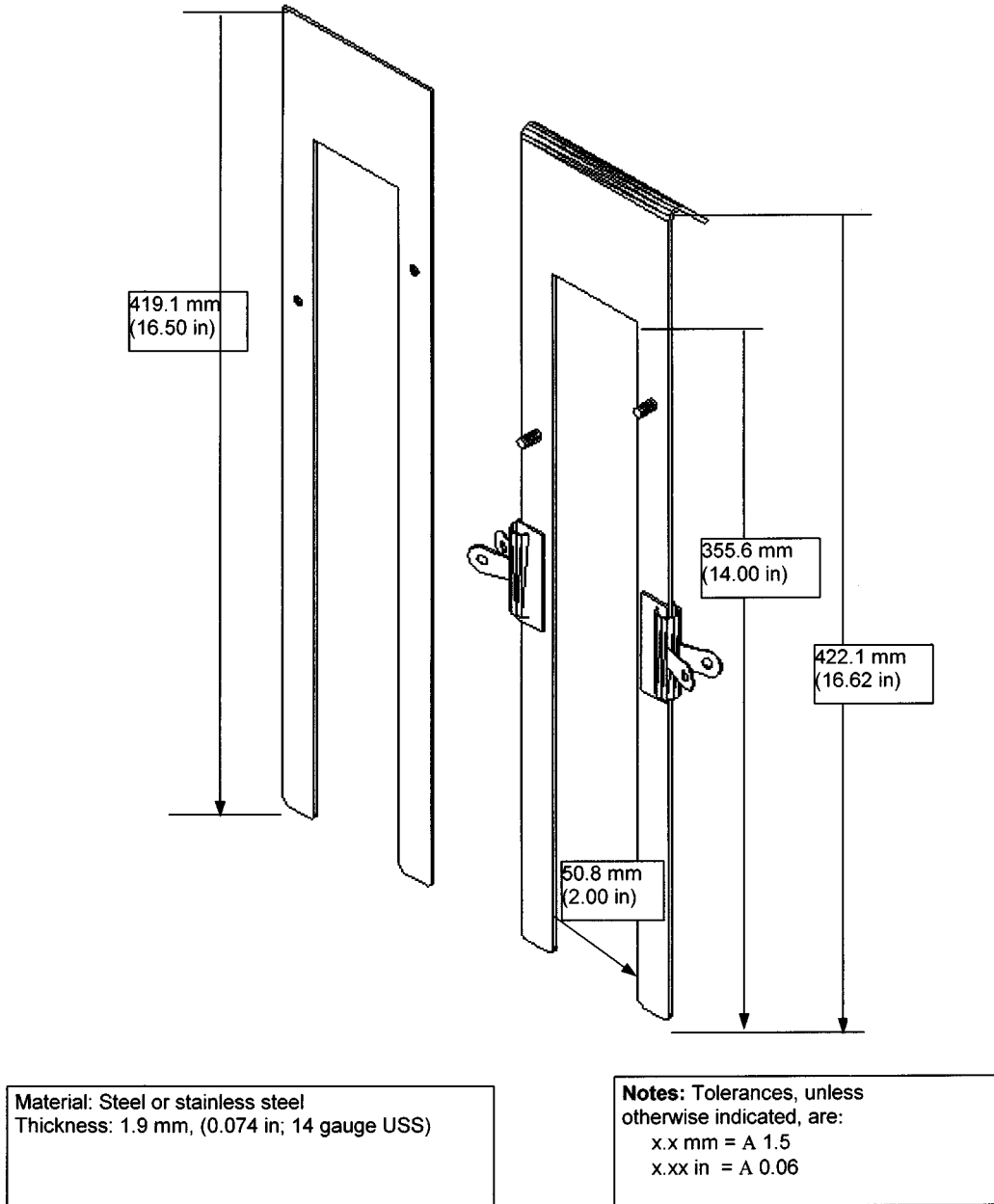

FIG. 5 Flame Height Indicator

- 11.1.2 Name of testing technician.
- 11.1.3 Name of fabric manufacturer producing sample.
- 11.1.4 Style of fabric sample.
- 11.1.5 Color (or color number) of fabric sample.
- 11.1.6 If a print, print style and description of fabric sample.
- 11.1.7 Condition (as produced, after one laundering, after 50 laundings).
- 11.1.8 Laundering procedure used for the 50 laundings, if different than specified.
- 11.1.9 Char length of each of the five specimens, and the average of the five values.

12. Precision and Bias

12.1 *Single-Laboratory Study*—In November, 1999, one laboratory tested two fabrics in accordance with this test

method, reporting results for a number of samples taken from several manufacturing lots for each fabric style. Each sample contained five specimens, in which either three or two testing in the warp direction, with the remaining two of three in the fill direction. The average of the values from the five specimens was the test result.

12.1.1 Data for each fabric was analyzed separately, using analysis of variance. For each fabric style, neither lots, nor samples in lots, showed any significance in relation to error variance. Accordingly, the variance for each of the combined data sets was used to determine precision.

12.1.2 Average values and error variance for the two fabrics were different enough to warrant reporting precision for the fabrics separately.

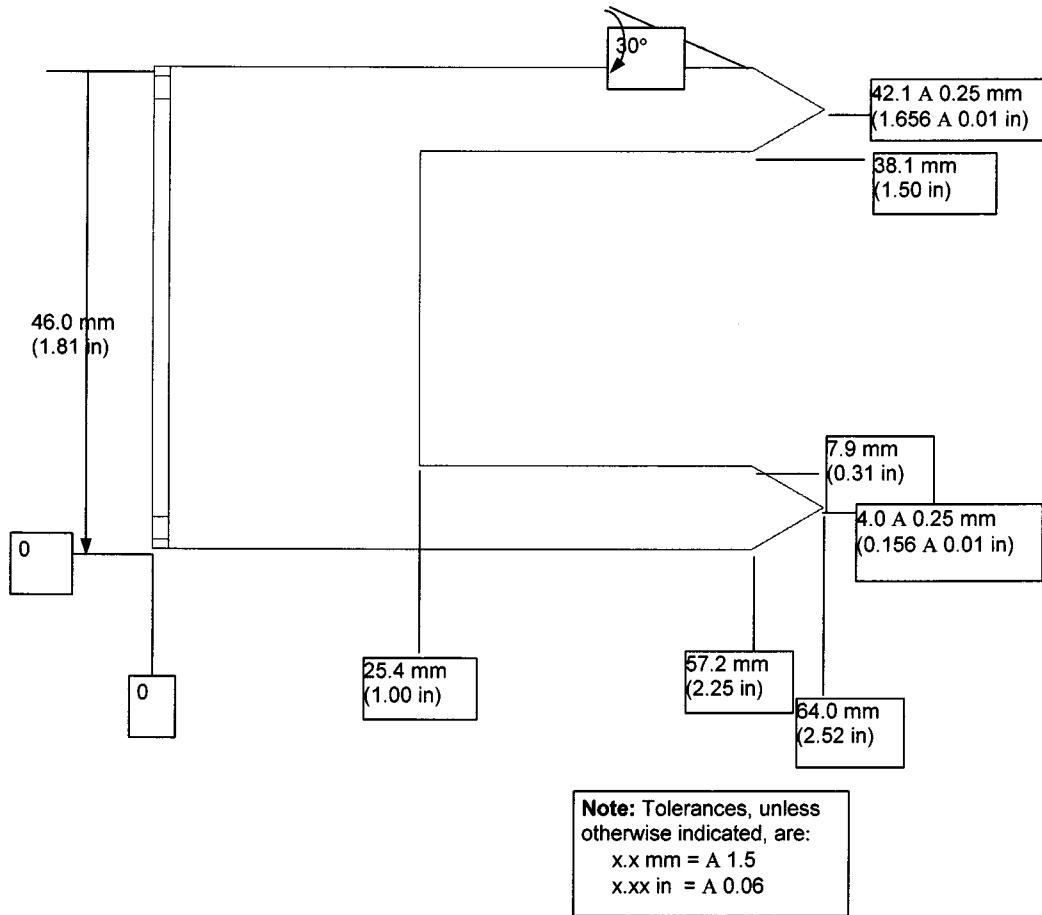

FIG. 6 Sample Holder, Plate (Left) and Frame with Clips

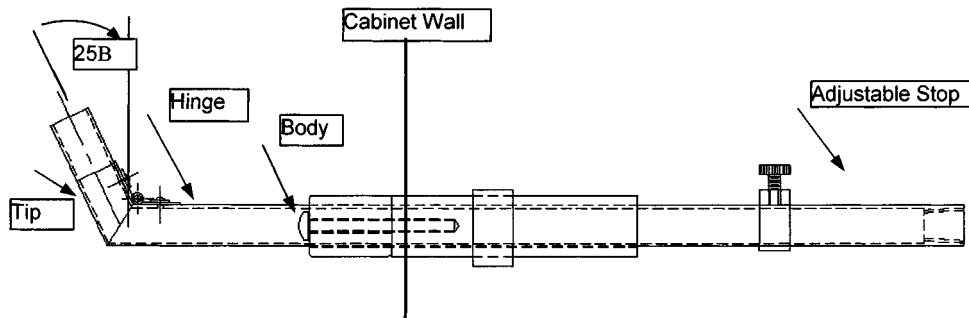

FIG. 7 Burner Arm Assembly (Side View)

12.2 Temporary Precision—On the basis of this single-laboratory determination, within-laboratory precision for each fabric is given as follows:

12.2.1 Average Char Length and Variance:

	Style X	Style Y
Grand average	3.4	4.3
Variance	1.19	7.38

12.2.2 Single Operator, Within-Laboratory Precision (95 % Level):

Style X ^A				Style Y ^A			
N	SE	CI	CD	N	SE	CI	CD
1	1.09	2.18	3.05	1	2.72	5.43	7.61
3	0.63	1.26	1.76	3	1.57	3.14	4.39
5	0.49	0.97	1.36	5	1.22	2.43	3.40
7	0.41	0.82	1.15	7	1.03	2.05	2.88

^AN = specimens in average; SE = standard error for N; CI = confidence interval; and CD = critical difference.

12.2.3 Interpretation—For averages of five specimens, the standard test result, 95 of such averages out a 100 should lie between 4.4 and 2.4 for Style X, and between 6.7 and 1.8 for

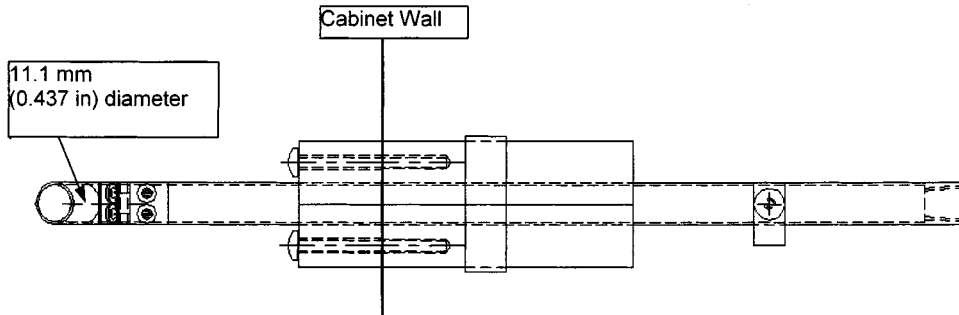

FIG. 8 Burner Arm Assembly (Top View)

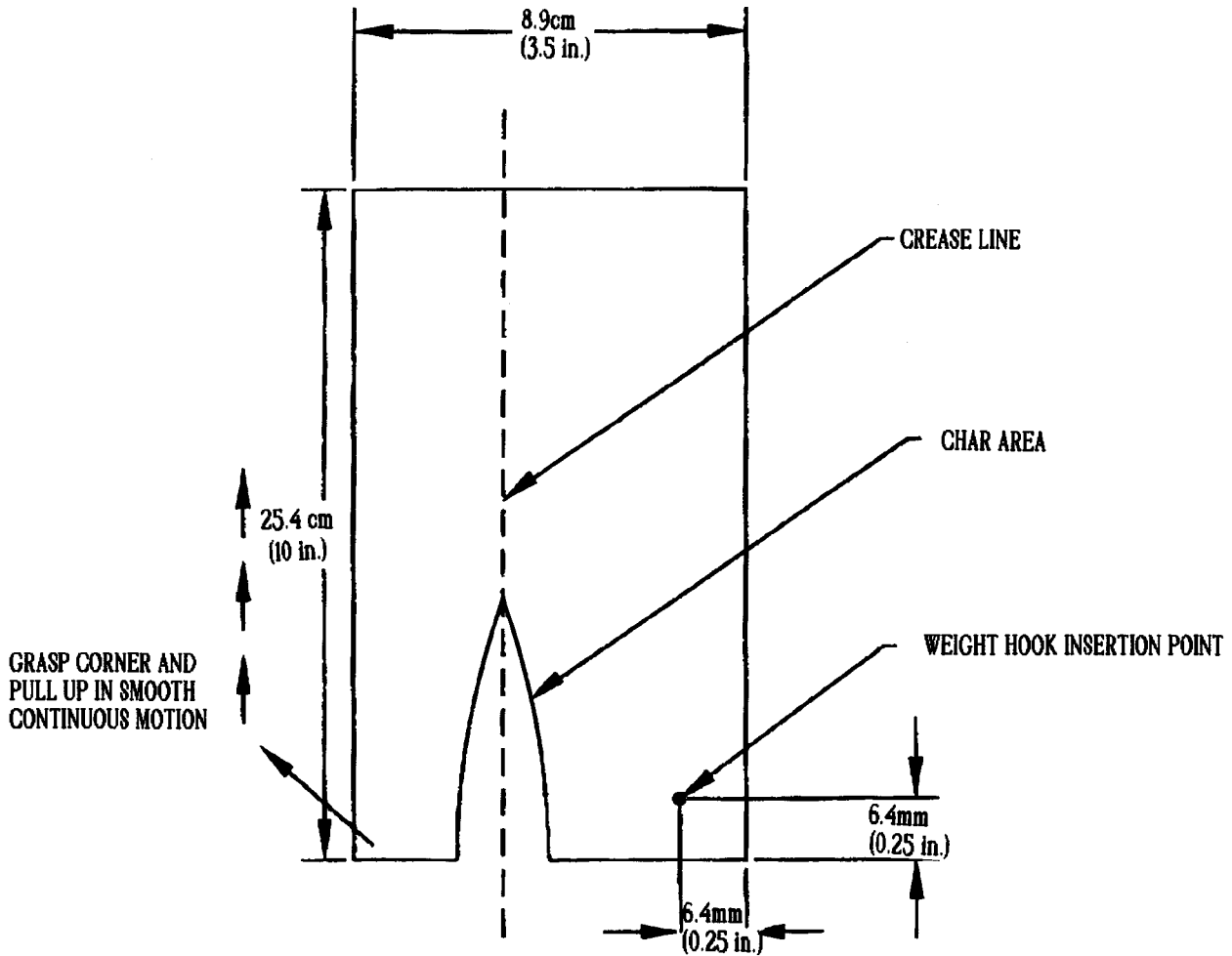

FIG. 9 Char Length Measurement

TABLE 1

Fabric Weight, g/m ² (oz/yd ²)		Loads, g (lb)	
Less than 101	less than 3	54.4 ± 0.5	0.12 ± 0.001
101 to 207	3 to 6	113.4 ± 0.5	0.25 ± 0.001
207 to 338	6 to 10	226.8 ± 1.0	0.50 ± 0.002
Greater than 338	greater than 10	340.2 ± 1.0	0.75 ± 0.002

Style Y. Differences between two test results equal to or greater than 1.36 for Style X and 3.40 for Style Y would be statistically different on a 95 % confidence level.

12.2.4 Since this precision determination is based on a limited study, test method users are urged to apply conven-

tional statistical caution in any inferences that may be drawn from it. A more complete interlaboratory study is to be done, and a precision statement written addressing both within-laboratory and between-laboratory precision, within the five-year period leading to next reapproval of this test method.

12.3 *Bias*—There is no independent, referee test method by which any bias in this test method may be determined.

12.3.1 The property of fabric flame resistance for children’s sleepwear can only be defined in terms of a test method.

12.3.2 This test method has no known bias.

13. Keywords

13.1 char length; children's sleepwear; Consumer Product Safety Commission; flammability; laundering; textile flame resistance

The American Society for Testing and Materials takes no position respecting the validity of any patent rights asserted in connection with any item mentioned in this standard. Users of this standard are expressly advised that determination of the validity of any such patent rights, and the risk of infringement of such rights, are entirely their own responsibility.

This standard is subject to revision at any time by the responsible technical committee and must be reviewed every five years and if not revised, either reapproved or withdrawn. Your comments are invited either for revision of this standard or for additional standards and should be addressed to ASTM Headquarters. Your comments will receive careful consideration at a meeting of the responsible technical committee, which you may attend. If you feel that your comments have not received a fair hearing you should make your views known to the ASTM Committee on Standards, at the address shown below.

This standard is copyrighted by ASTM, 100 Barr Harbor Drive, PO Box C700, West Conshohocken, PA 19428-2959, United States. Individual reprints (single or multiple copies) of this standard may be obtained by contacting ASTM at the above address or at 610-832-9585 (phone), 610-832-9555 (fax), or service@astm.org (e-mail); or through the ASTM website (www.astm.org).