



Designation: D-1238—01^{€1} 1238 – 04

Standard Test Method for Melt Flow Rates of Thermoplastics by Extrusion Plastometer¹

This standard is issued under the fixed designation D 1238; the number immediately following the designation indicates the year of original adoption or, in the case of revision, the year of last revision. A number in parentheses indicates the year of last reapproval. A superscript epsilon (ϵ) indicates an editorial change since the last revision or reapproval.

~~^{€1} NOTE—Editorially corrected the Notes in Figure 3 in April 2002.~~

~~^{€2} NOTE—Editorially corrected condition value listed under 8.2 in April 2002.~~

1. Scope*

1.1 This test method covers measurement of the rate of extrusion of molten resins through a die of a specified length and diameter under prescribed conditions of temperature, load, and piston position in the barrel as the timed measurement is being made.

1.2 Procedure A is a manual cutoff operation based on time used for materials having flow rates that fall generally between 0.15 and 50 g/10 min. Procedure B is an automatically timed flow rate measurement used for materials having flows from 0.50 to 900 g/10 min. By both procedures, the piston travel is generally the same during the timed measurement; the piston foot is about 46 and 20.6 mm above the die. Comparable flow rates have been obtained by these procedures in interlaboratory round-robin measurements of several materials described in 13.1. Provision is made for calculation of melt volume-flow rate as well as melt mass-flow rate.

NOTE 1—Round-robin testing indicates this test method may be suitable at flow rates up to 1500 g/10 min if the timing clock resolves the elapsed time to the nearest 0.01 s.

NOTE 2—This test method and ISO 1133-1991 are technically equivalent.

1.3 *This standard does not purport to address the safety concerns, if any, associated with its use. It is the responsibility of the user of this standard to establish appropriate safety and health practices and determine the applicability of regulatory limitations prior to use.* Specific precautionary statements are given in ~~Note 10, Note 26, 5.7, 10.2.12, and Note 29:~~ 14.1.2.

¹ This test method is under the jurisdiction of ASTM Committee D20 on Plastics and is the direct responsibility of Subcommittee D20.30 on Thermal Properties (Section D20.30.08).

Current edition approved ~~August 10, 2001,~~ March 1, 2004. Published ~~October 2001,~~ April 2004. Originally published as D-1238—65-F, approved in 1965. Last previous edition approved in 2001 as D 1238 — 001^{€1}.

*A Summary of Changes section appears at the end of this standard.

2. Referenced Documents

2.1 ASTM Standards:²

D 618 Practice for Conditioning Plastics for Testing

D 883 Terminology Relating to Plastics

E 691 Practice for Conducting an Interlaboratory Study to Determine the Precision of a Test Method

2.2 ANSI Standard:

B46.1 on Surface Texture³

2.3 ISO Standard:

ISO 1133-1991 Determination of the Melt-Mass Flow Rate (MFR) and the Melt Volume-Flow Rate (MVR) of Thermoplastics³

3. Terminology

3.1 General:

3.1.1 For definition of some of the technical terms used in this test method refer to Terminology D 883.

4. Significance and Use

4.1 This test method is particularly useful for quality control tests on thermoplastics.

NOTE 3—Polymers having flow rates less than 0.15 or greater than 900 g/10 min may be tested by the procedures in this test method; however, precision data have not been developed.

4.2 This test method serves to indicate the uniformity of the flow rate of the polymer as made by an individual process and, in this case, may be indicative of uniformity of other properties. However, uniformity of flow rate among various polymers as made by various processes does not, in the absence of other tests, indicate uniformity of other properties.

4.3 The flow rate obtained with the extrusion plastometer is not a fundamental polymer property. It is an empirically defined parameter critically influenced by the physical properties and molecular structure of the polymer and the conditions of measurement. The rheological characteristics of polymer melts depend on a number of variables. Since the values of these variables occurring in this test may differ substantially from those in large-scale processes, test results may not correlate directly with processing behavior.

4.4 The flow rate of a material may be measured under any of the conditions listed for it in 8.2. Additional characterization of a material can be obtained if more than one condition is used. In case two conditions are employed, a Flow Rate Ratio (FRR) may be obtained by dividing the flow rate at one condition by the flow rate at the other condition.

5. Apparatus

5.1 Plastometer:

5.1.1 The apparatus shall be a dead-weight piston plastometer consisting of a thermostatically controlled heated steel cylinder with a die at the lower end and a weighted piston operating within the cylinder. The essential features of the plastometer, illustrated in Figs. 1 and 2, are described in 5.2-5.8. All dimensional measurements shall be made when the article being measured is at $23 \pm 5^\circ\text{C}$.

5.1.2 Relatively minor changes in the design and arrangement of the component parts have been shown to cause differences in results among laboratories. It is important, therefore, for the best interlaboratory agreement that the design adhere closely to the description herein; otherwise, it should be determined that modifications do not influence the results.

5.2 *Cylinder*—The steel cylinder shall be 50.8 mm in diameter, 162 mm in length with a smooth, straight hole 9.5504 ± 0.0076 mm in diameter, displaced 4.8 mm from the cylinder axis. Wells for a thermal sensor (thermoregulator, thermistor, etc.) and thermometer shall be provided as shown in Fig. 1. A 3.2-mm plate shall be attached to the bottom of the cylinder to retain the die. A hole in this plate, centered under the die and countersunk from below, allows free passage of the extrudate. The cylinder may be supported by at least two 6.4-mm high-strength screws at the top (radially positioned at right angles to the applied load) or by at least two 10-mm diameter rods screwed into the side of the cylinder for attaching to a vertical support. The essential dimensions of a satisfactory cylinder of this type are shown in Fig. 1 (Note 4). The cylinder bore should be finished by techniques known to produce approximately 12 rms or better in accordance with ANSI B46.1.

NOTE 4—Cylinders made of SAE 52100 or other equivalent steel heat-hardened to 60–65 Rockwell Hardness Scale C give good service when used at temperatures below 200°C . Cylinder liners of cobalt-chromium-tungsten alloy are also satisfactory to 300°C .

5.3 *Die*—The outside of the steel die shall be such diameter that it will fall freely to the bottom of the 9.5504 ± 0.0076 mm diameter hole in the cylinder (Note 5). The die shall have a smooth straight bore 2.0955 ± 0.0051 mm in diameter and shall be 8.000 ± 0.025 mm in length. The bore and its finish are critical. It shall have no visible drill or other tool marks and no detectable eccentricity. The die bore shall be finished by techniques known to produce approximately 12 rms or better in accordance with ANSI B46.1.

² For referenced ASTM standards, visit the ASTM website, www.astm.org, or contact ASTM Customer Service at service@astm.org. For *Annual Book of ASTM Standards*, Vol 08.01, volume information, refer to the standard's Document Summary page on the ASTM website.

Annual Book of ASTM

³ Available from American National Standards, Vol 14.02, Institute (ANSI), 25 W. 43rd St., 4th Floor, New York, NY 10036.

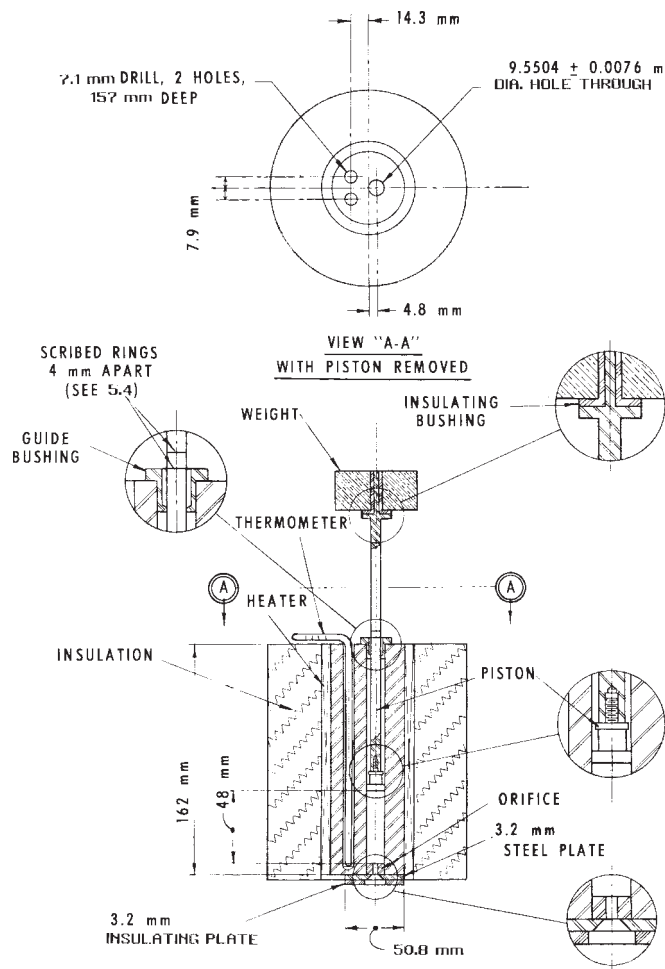

FIG. 1 General Arrangement of Extrusion Plastometer

NOTE 5—Recommended die material is tungsten carbide. Also satisfactory are steel, synthetic sapphire, and cobalt-chromium-tungsten alloy.

5.4 Piston:

5.4.1 The piston shall be made of steel with an insulating bushing at the top as a barrier to heat transfer from the piston to the weight. The land of the piston shall be 9.4742 ± 0.0076 mm in diameter and 6.35 ± 0.13 mm in length. The piston design may incorporate means for land replacement, for example, having threads and flats immediately above the land. Above the land, the piston shall be no larger than 8.915 mm in diameter (Note 6). The finish of the piston foot shall be 12 rms in accordance with ANSI B46.1. If wear or corrosion is a problem, the piston should be of stainless steel and equipped with a detachable foot for ease of replacement.

NOTE 6—To improve standardization it is preferable that the piston be guided with a loose-fitting metal sleeve at the top of the cylinder.

NOTE 7—Pistons of SAE 52100 steel with the bottom 25 mm, including the foot, hardened to a Rockwell hardness, C scale, of 55 to 59 have been found to give good service when used at temperatures below 200°C.

5.4.2 The piston shall be scribed with two reference marks 4 mm apart in such fashion that when the lower mark coincides with the top of the cylinder or other suitable reference point, the bottom of the piston is 48 mm above the top of the die (see Fig. 1).

5.4.3 The combined weight of piston and load shall be within a tolerance of ± 0.5 % of the selected load.

5.5 Heater:

5.5.1 The equipment must have a heater capable of heating the apparatus so that the temperature at 10 mm above the die can be maintained within $\pm 0.2^\circ\text{C}$ of the desired temperature during the test. The temperature of the barrel, from 10 mm to 75 mm above the top of the die, must be maintained within ± 1 % of the set temperature ($^\circ\text{C}$).

NOTE 8—At temperatures higher than 200°C this degree of temperature control may be more difficult to obtain.

5.5.2 Calibrate the temperature-indicating device by means of a light-gage probe-type thermocouple or a platinum-resistance

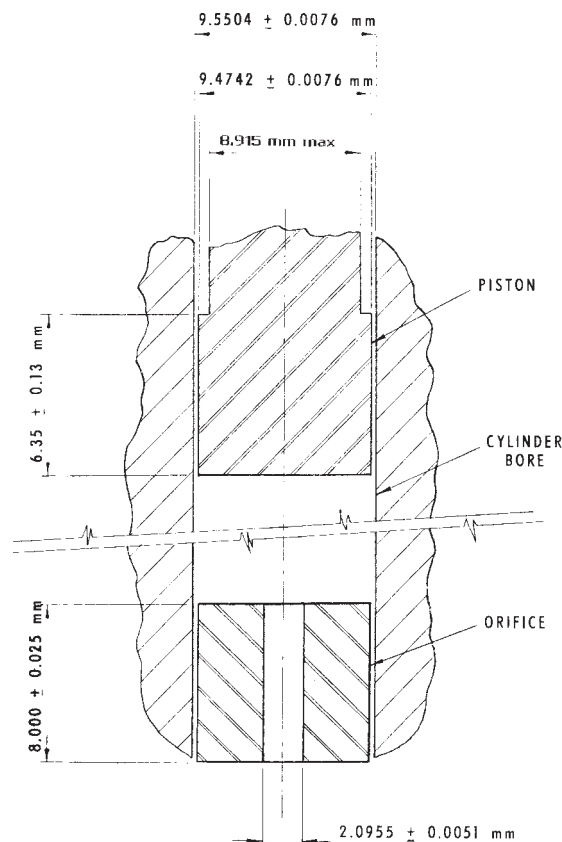

FIG. 2 Details of Extrusion Plastometer

temperature sensor having a short sensing length.⁴ The thermocouple should be encased in a metallic sheath having a diameter of approximately 1.6 mm with its hot junction grounded to the end of the sheath. Insert the temperature sensor into the melt from the top of the cylinder so that it is 10 ± 1 mm above the upper face of the die. The temperature sensors shall be used with a potentiometer having a sensitivity of at least 0.005 mV, or a temperature readout having a sensitivity of at least 0.1°C. Calibration should also be verified at 75 mm above the upper face of the die. An alternate technique for calibration is to use a sheathed thermocouple or platinum-resistance temperature sensor with tip diameter of 9.4 ± 0.1 mm for insertion in the bore without material present. An example of this is shown in Fig. 3. Calibration of the temperature-indicating device shall be verified at each run temperature.

NOTE 9—The response of the temperature sensing device may be affected by immersion level. Take care to ensure adequate insulation of the device sensor and stabilization of the barrel temperature.

5.5.3 Heat shall be supplied by electric band heater(s) covering the entire length of the cylinder. The heater(s) may be single- or multi-element, depending upon the manufacturer's control means. The heater(s) plus control system must be capable of maintaining the temperature within the required $\pm 0.2^\circ\text{C}$ of the set point. The temperature sensor and readout equipment must be calibrated to a traceable national standard (that is, NIST) at least once per year. The cylinder with the heater(s) shall be lagged with 38 mm of foamed-glass insulation. An insulating plate 3.2 mm in thickness shall be attached to the bottom of the cylinder to minimize heat loss at this point.

5.6 *Temperature Controller*—The type of controller and sensor must be capable of meeting the required control tolerance specified in 5.5.1.

5.7 *Thermometer*—Thermometers having a range of 4°C graduated in 0.2°C divisions may be used to indicate temperature. The temperature at this point may not necessarily be the temperature of the material 10 mm above the die. The thermometer may be used to monitor indirectly the temperature of the material 10 mm above the die and may be calibrated by reference to a thermocouple or platinum resistance temperature sensor inserted in the material 10 mm above the die. See 5.5.2 for a description of a method for measuring temperature. **Warning**— Caution should be observed with the use of a mercury-filled thermometer. Mercury vaporization occurs if the thermometer is broken. Mercury thermometers are not to be used at or above the boiling point of mercury, which is 357°C .

⁴ Available from

⁴ Round-robin data showing flow rate and corresponding temperature profile of the American National Standards Institute, 11 West 42nd St., 13th Floor, New York, NY 10036; melt obtained using probe-type thermocouples and platinum resistance temperature sensors can be obtained from ASTM Headquarters. Request RR:D20-1094.

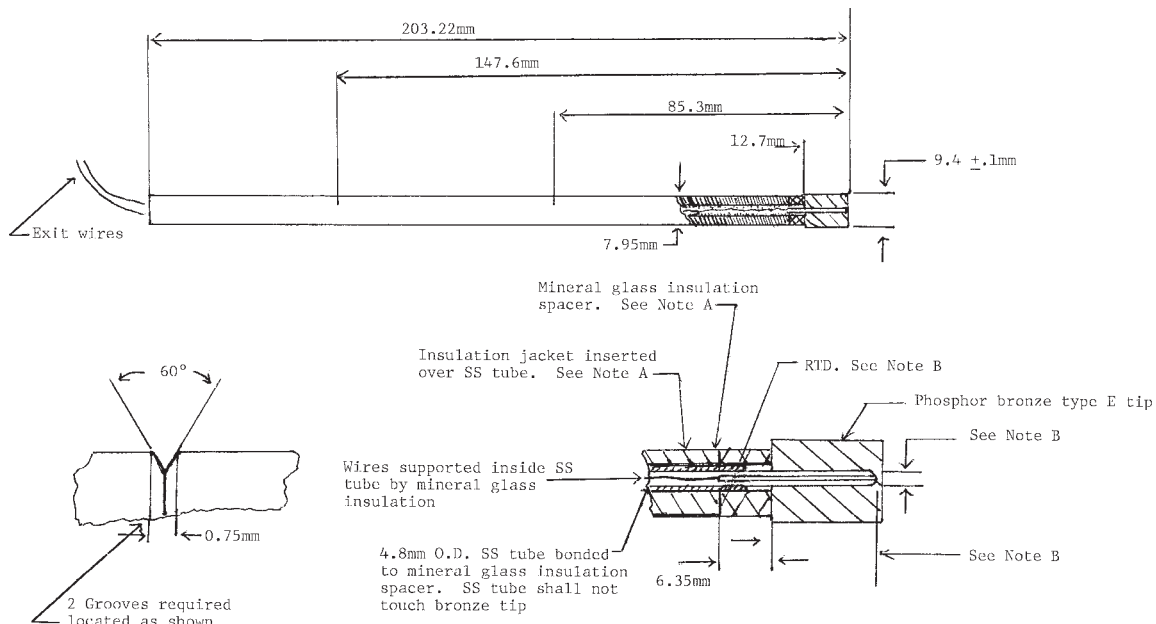

FIG. 3 Example of a Temperature Calibration Device

Note A—Mineral glass insulation or equivalent spacer shall be bonded to tip and SS tube. Bond material shall be low conductivity type, 400°C minimum rating. Insulation jacket material shall be low conductivity type (400°C minimum rating preferred, see Note 5).

Note B—The RTD shall be inserted into bronze tip and bonded using high conductivity, 400°C rated material. Tip of RTD element shall touch the bronze tip. Minimum insertion depth of 11.2 mm clearance between RTD and tip wall shall be minimized.

NOTE 10—**Warning:** Caution should be observed with the use of a mercury-filled thermometer. Mercury vaporization occurs if the thermometer is broken. Mercury thermometers are not to be used at or above the boiling point of mercury, which is 357°C.

5.8 *Level*—Provision shall be made for vertical alignment of the bore of the extrusion plastometer. This is necessary to minimize subtractive loads resulting from rubbing or friction between the piston tip and sidewall. Means of alignment are discussed in Appendix X1.

5.9 *Accessory Equipment*—Necessary accessories include equipment for charging samples to the cylinder, a funnel, a die plug, a tool for cutting off the extruded sample, a timer or stop watch, cleaning equipment, go/no-go gages, a balance accurate to ±0.001 g, and, when required, a weight or weight-piston support.

NOTE 11—Satisfactory operation of the apparatus for polyethylenes can be ascertained by making measurements on NIST Standard Reference Materials (SRMs) certified for melt flow rate. The four SRMs certified under condition 190/2.16 are SRM 1473 with a flow rate of 1.29 g/min, SRM 1474 with a flow rate of 5.03 g/10 min, SRM 1496 with a flow rate of 0.26 g/10 min, and SRM 1497 with a flow rate of 0.19 g/10 min. SRM 1475a is certified under condition 190/3.25 with a flow rate of 2.20 g/10 min.⁵

6. Test Specimen

6.1 The test specimen may be in any form that can be introduced into the bore of the cylinder, for example, powder, granules, strips of film, or molded slugs. It may be desirable to preform or pelletize a powder.

7. Conditioning

7.1 Many thermoplastic materials do not require conditioning prior to testing. Materials which contain volatile components, are chemically reactive, or have other special characteristics most probably require appropriate conditioning procedures. Moisture not only affects reproducibility of flow rate measurement but, in some types of materials, degradation is accelerated by moisture at the high temperatures used in testing. Check the applicable material specification for any conditioning requirements before using this test. See Practice D 618 for appropriate conditioning practices.

8. Procedural Conditions

8.1 Standard conditions of test are given in Table 1. Test conditions shall be shown as: Condition ___ / ___, where the temperature in degrees Celsius is shown first, followed by the weight in kilograms. For example: Condition 190/2.16.

⁴ Round-robin data showing flow rate and corresponding temperature profile of

⁵ These standard polyethylenes are available from the melt obtained using probe-type thermocouples National Institute of Standards and platinum-resistance-temperature sensors can be obtained from ASTM Headquarters. Request RR-D20-1094. Technology, Office of Standard Reference Materials, Washington, DC 20234.

TABLE 1 Standard Test Conditions, Temperature, and Load

| Condition Standard Designation | Temperature, °C | Total Load Including Piston, kg | Approximate Pressure | |
|-----------------------------------|-----------------|---------------------------------|----------------------|-------|
| | | | kPa | psi |
| 80/2.16 | 80 | 2.16 | | |
| 125/0.325 | 125 | 0.325 | 44.8 | 6.5 |
| 125/2.16 | 125 | 2.16 | 298.2 | 43.25 |
| 150/2.16 | 150 | 2.16 | 298.2 | 43.25 |
| 190/0.325 | 190 | 0.325 | 44.8 | 6.5 |
| 190/2.16 | 190 | 2.16 | 298.2 | 43.25 |
| 190/21.60 | 190 | 21.60 | 2982.2 | 432.5 |
| 200/5.0 | 200 | 5.0 | 689.5 | 100.0 |
| 230/1.2 | 230 | 1.2 | 165.4 | 24.0 |
| 230/3.8 | 230 | 3.8 | 524.0 | 76.0 |
| 265/12.5 | 265 | 12.5 | 1723.7 | 250.0 |
| 275/0.325 | 275 | 0.325 | 44.8 | 6.5 |
| 230/2.16 | 230 | 2.16 | 298.2 | 43.25 |
| 190/1.05 | 190 | 1.05 | 144.7 | 21.0 |
| 190/10.0 | 190 | 10.0 | 1379.0 | 200.0 |
| 300/1.2 | 300 | 1.2 | 165.4 | 24.0 |
| 190/5.0 | 190 | 5.0 | 689.5 | 100.0 |
| 235/1.0 | 235 | 1.0 | 138.2 | 20.05 |
| 235/2.16 | 235 | 2.16 | 298.2 | 43.25 |
| 235/5.0 | 235 | 5.0 | 689.5 | 100.0 |
| 250/2.16 | 250 | 2.16 | 298.2 | 43.25 |
| 310/12.5 | 310 | 12.5 | 1723.7 | 250.0 |
| 210/2.16 | 210 | 2.16 | 298.2 | 43.25 |
| 285/2.16 | 285 | 2.16 | 298.2 | 43.25 |
| 315/5.0 | 315 | 5.0 | 689.5 | 100.0 |
| 372/2.16 | 372 | 2.16 | 298.2 | 43.25 |
| 372/5.0 | 372 | 5.0 | 689.5 | 100 |
| 297/5.0 | 297 | 5.0 | 689.5 | 100 |
| 230/21.6 | 230 | 21.6 | 2982.2 | 432.5 |
| 230/5.0 | 230 | 5.0 | 689.5 | 100 |
| 265/21.6 | 265 | 21.6 | 2982.2 | 432.5 |
| 265/31.6 | 265 | 31.6 | 4361.2 | 632.5 |
| 271.5/2.16 | 271.5 | 2.16 | 298.2 | 43.25 |
| 220/10 | 220 | 10.0 | 1379.0 | 200.0 |
| 250/1.2 | 250 | 1.2 | 165.4 | 24.0 |
| 265/3.8 | 265 | 3.8 | 524.0 | 76.0 |
| 265/5 | 265 | 5.0 | 689.5 | 100.0 |

8.2 The following conditions have been found satisfactory for the material listed:

| Material | Condition |
|--|--------------------|
| Acetals (copolymer and homopolymer) | 190/2.16 190/1.05 |
| Acrylics | 230/1.2 230/3.8 |
| Acrylonitrile-butadiene-styrene | 200/5.0 230/3.8 |
| | 220/10 |
| Acrylonitrile/butadiene/styrene/polycarbonate blends | 230/3.8 250/1.2 |
| | 265/3.8 265/5.0 |
| Cellulose esters | 190/0.325 190/2.16 |
| | 190/21.60 210/2.16 |
| Ethylene-chlorotrifluoroethylene copolymer | 271.5/2.16 |
| Ethylene-tetrafluoroethylene copolymer | 297/5.0 |
| Nylon | 275/0.325 235/1.0 |
| | 235/2.16 235/5.0 |
| | 275/5.0 |
| Perfluoro(ethylene-propylene) copolymer | 372/2.16 |
| Perfluoroalkoxyalkane | 372/5.0 |
| Polycaprolactone | 125/2.16 80/2.16 |
| Polychlorotrifluoroethylene | 265/12.5 |
| Polyether sulfone (PES) | 380/2.16 360/10 |
| | 343/2.16 |
| Polyethylene | 125/0.325 125/2.16 |
| | 250/1.2 |
| | 190/0.325 190/2.16 |
| | 190/21.60 190/10 |
| | 310/12.5 |
| Polycarbonate | 300/1.2 |
| Polymonochlorotrifluoroethylene | 265/21.6 265/31.6 |
| Polypropylene | 230/2.16 |
| Polyphenyl sulfone (PPSU) | 365/5.0 380/2.16 |
| Polystyrene | 200/5.0 230/1.2 |
| | 230/3.8 190/5.0 |



| | | |
|-------------------------------------|----------|----------|
| Polysulfone (PSU) | 343/2.16 | 360/10 |
| Polyterephthalate | 250/2.16 | 210/2.16 |
| | 285/2.16 | |
| Poly(vinyl acetal) | 150/21.6 | |
| Poly(vinylidene fluoride) | 230/21.6 | |
| | 230/5.0 | |
| Poly(phenylene sulfide) | 315/5.0 | |
| Styrene acrylonitrile | 220/10 | 230/10 |
| | 230/3.8 | |
| Styrenic Thermoplastic Elastomer | 190/2.16 | 200/5.0 |
| Thermoplastic Elastomer-Ether-Ester | 190/2.16 | 220/2.16 |
| | 230/2.16 | 240/2.16 |
| | | 250/2.16 |
| Thermoplastic elastomers (TEO) | 230/2.16 | |
| Vinylidene fluoride copolymers | 230/21.6 | |
| | 230/5.0 | |

for $T_m = 100^\circ$ use 120/5.0 or 21.6

NOTE 12—Some materials may require special materials of construction or handling for performing this test. Please refer to the material specification for appropriate recommendations.

8.3 If more than one condition is used and the material is polyethylene, the determination of Flow Rate Ratio (FRR) has been found to be useful. The FRR is a dimensionless number derived by dividing the flow rate at Condition 190/10 by the flow rate at Condition 190/2.16.

NOTE 13—When determining such a ratio of flow rates for a material at the same temperature under different loads, it has been found that precision is maximized when one operator uses one Procedure (A or B), the same plastometer, and the same die for both measurements (the die need not be removed from the plastometer between the two determinations).

9. Procedure A—Manual Operation

9.1 Select conditions of temperature and load from Table 1 in accordance with material specifications such that flow rates will fall between 0.15 to 50 g/10 min.

9.2 Ensure that the bore of the extrusion plastometer is properly aligned in the vertical direction. (See Appendix X1.)

9.3 Inspect the apparatus and die for cleanliness. If it is not clean, see 9.11.

NOTE 14—The degree of cleanliness can significantly influence the flow rate results, therefore a thorough method of cleaning must be established. It has been found that three swabs of the barrel is satisfactory for most materials and that the die, barrel, and piston are more easily cleaned while hot.

9.4 Check the die bore diameter with appropriately sized no-go/go gages prior to testing. Make frequent checks to determine whether the die diameter (tested with die at $23 \pm 5^\circ\text{C}$) is within the tolerances given in 5.3.

NOTE 15—Cleaning and usage can result in a die diameter that is out of specifications. Data has shown that erroneous results will be obtained if the die diameter is not within the appropriate tolerances.

9.5 Verify that the temperature is stable and within $\pm 0.2^\circ\text{C}$ of the appropriate test temperature as specified in 5.5.1.

9.6 Insert the die and the piston. The temperature of the cylinder with the piston and die in place must be stable at the appropriate test temperature 15 min before testing is begun. When equipment is used repetitiously, it should not be necessary to heat the piston and die for 15 min.

NOTE 16—The reduction in heating time when the unit is being used repetitiously is only allowed when runs of the same or similar material are being measured over a continuous time frame. If the piston and die are removed and cleaned, they should be considered “cold” and the full 15 minutes heating stabilization time required.

9.7 Remove the piston and place it on an insulated surface. Charge the cylinder within 1 min with a weighed portion of the sample ~~according to~~ in accordance with the expected flow rate, as given in Table 2. Reinsert the piston and add the appropriate weight.

NOTE 17—Experience has shown that for the best reproducibility the piston should operate within the same part of the cylinder for each measurement. The piston is scribed so the starting point for each extrusion is roughly the same. Some excess of material over the minimum required for the actual flow measurement portion of the test is provided by the charging weights shown in Table 2. This is necessary to achieve a void-free extrudate and flow equilibrium before start of rate measurements.

NOTE 18—It is frequently helpful to take interim cuts of the extrudate at uniform time intervals during the specified extrusion time. Weights of these individual cuts give an indication of the presence of bubbles which may be masked due to their size or to opacity of the sample. This technique is particularly helpful in the case of highly pigmented materials. Forcing out some of the resin manually during the preheat period often eliminates bubbles in the test extrudate.

9.8 Allow time for the material to soften and begin to melt, and then purge some material to a position such that subsequent travel of the piston will position the lower scribe mark at the reference start position 7.0 ± 0.5 min from the completion of the charge. Purge must be completed at least 2 min prior to start of the test for materials having melt flow rates less than 10 g/10 min.

NOTE 19—It has been found that purging within 60 s of the start time will result in higher variability in the data.

NOTE 20—There may be cases where the 7.0 ± 0.5 min is too much or not enough preheat time. For those materials, provisions must be in the material documents. It is necessary to refer to the appropriate material document before beginning any test.

**TABLE 2 Standard Test Conditions, Sample Mass,^A and Testing Time^B**

| Flow Range, g/10 min | Suggested Mass of Sample in Cylinder, g | Time Interval, min | Factor for Obtaining Flow Rate in g/10 min |
|----------------------|---|--------------------|--|
| 0.15 to 1.0 | 2.5 to 3.0 | 6.00 | 1.67 |
| >1.0 to 3.5 | 3.0 to 5.0 | 3.00 | 3.33 |
| >3.5 to 10 | 4.0 to 8.0 | 1.00 | 10.00 |
| >10 to 25 | 4.0 to 8.0 | 0.50 | 20.00 |
| >25 | 4.0 to 8.0 | 0.25 | 40.00 |

^A This is a suggested mass for materials with melt densities of about 0.7 g/cm³. Correspondingly, greater quantities are suggested for materials of greater melt densities. Density of the molten resin (without filler) may be obtained using the procedure described by Terry, B. W., and Yang, K., "A New Method for Determining Melt Density as a Function of Pressure and Temperature," *SPE Journal*, SPEJA, Vol. 20, No. 6, June 1964, p. 540 or the procedure described by Zoller, Paul, "The Pressure-Volume-Temperature Properties of Polyolefins," *Journal of Applied Polymer Science*, Vol 23, 1979, p. 1051. It may also be obtained from the weight of an extruded known volume of resin at the desired temperature. For example, 25.4 mm (1 in.) of piston movement extrudes 1.804 cm³ of resin. An estimate of the density of the material can be calculated from the following equation:

$$\text{resin density at test temperature} = M/1.804$$

where:

M = mass of extruded resin.

^B See 9.14.

NOTE 21—Additional care may be necessary to prevent thermal degradation in the extrusion plastometer. This is sometimes done by the addition of an appropriate antioxidant. For highly unstable materials, it may be necessary to use alternative techniques as an indication of flow characteristics.

9.9 For materials with flow rates greater than 10 g/10 min, a weight (and if needed, a piston) support must be used after the initial purge. The support shall be removed at such a time as to allow the test to begin within 7 ± 0.5 min of the completion of the charge. The piston/weight support should be of such a length that the lower scribe mark of the supported piston/weight will be 25 mm above the top of the guide bushing or other suitable reference mark.

NOTE 22—It has been found that the effect of choosing plugging, weight support, or both, is significant to the flow rate results. The choice of piston support was made to cover all conditions and flow rates 10 to 50 g/10 min.

9.10 For all tests, start collecting a timed extrudate when requirements for the piston position are met, provided this is within 7.0 ± 0.5 min from the end of charging; otherwise, discard the charge and repeat the test with readjusted piston position after the initial purge, or change weights. Requirements are that the top scribed mark on the piston be visible above the cylinder or index and that the lower scribe mark be in the cylinder or below the index. As the lower scribed mark approaches the top of the cylinder or index, reset the timer to zero, then simultaneously start the timer and make the initial cut-off when the position requirements are met. Make the final cut-off exactly when the time interval given in Table 2 is reached. Collect the timed extrudate. If the extrudate contains visible bubbles, discard the complete charge and begin the test again.

NOTE 23—The charge weight should only be increased if no material is being purged and there is still not enough material to complete the test.

9.11 Discharge the remainder of the specimen and push the die out through the top of the cylinder. Swab out the cylinder with cloth patches after the manner of cleaning a pistol barrel. The die may be cleaned by dissolving the residue in a solvent. A better method is pyrolytic decomposition of the residue in a nitrogen atmosphere. Place the die in a tubular combustion furnace or other device for heating to $550 \pm 10^\circ\text{C}$ and clean with a small nitrogen purge through the die. This method is preferable to flame or solvent cleaning, being faster than solvent cleaning and less detrimental to the die than an open flame. In certain cases where materials of a given class having similar flow characteristics are being tested consecutively, interim die cleaning may be unnecessary. In such cases, however, the effect of cleaning upon flow rate determination must be shown to be negligible if this step is avoided.

9.12 Once the extrudate is cool, weigh to the nearest 1 mg.

9.13 Multiply the weight of the extrudate by the appropriate factor shown in Table 2 to obtain the flow rate in grams per 10 min.

NOTE 24—Frequently, errors in test technique, apparatus geometry, or test conditions, which defy all but the most careful scrutiny exist, causing discrepancy in flow rate determinations. The existence of such errors is readily determined by periodically measuring a reference sample of known flow rate. The flow rate value and range to be tolerated can be determined using a statistically correct test program composed of multiple determinations with various instruments. Standard samples of polyethylene, linear or branched, are available from the National Institute of Standards and Technology.

9.14 In case a specimen has a flow rate at the borderline of the ranges in Table 2 and slightly different values are obtained at different time intervals, the referee value shall be obtained at the longer time interval.

10. Procedure B—Automatically Timed Flow Rate Measurement

10.1 Apparatus:

10.1.1 Extrusion plastometer and auxiliary equipment are detailed in Section 4 and below.

10.1.2 A timing device shall electrically, optically, or mechanically time piston movement within the specified travel range. The requirements of the system are as follows:

10.1.2.1 Sense and indicate the piston travel time within ± 0.01 s (see Note 1).

10.1.2.2 Measure piston travel within ± 0.4 % of the nominal preset value (see 10.1.2.4 and 10.1.2.5) for use in the flow rate calculations.

10.1.2.3 Any effects on the applied load must be included in the allowable tolerance given in 5.4.3.

10.1.2.4 It should be preset or be settable for measuring piston travel of 6.35 ± 0.25 mm for flow rates up to 10 g/10 min.

10.1.2.5 It should be preset or be adjustable for measuring piston travel of 25.4 ± 0.25 mm for flow rates greater than 10 g/10 min.

10.1.2.6 To ensure high interlaboratory reproducibility, it is important that the timing device operates within a fixed portion of the cylinder. This is defined as the portion of the cylinder between 46 ± 2 mm and 20.6 ± 2 mm above the top of the die.

10.1.2.7 Check die, cylinder, and position dimensions for conformance to 5.2-5.4 and Figs. 1 and 2.

10.2 Procedure:

10.2.1 Refer to Table 1 for selection of conditions of temperature and load in accordance with the material specification.

10.2.2 Check the die bore diameter with appropriately sized no-go/go gages prior to testing. Make frequent checks to determine whether the die diameter (tested with die at $23 \pm 5^\circ\text{C}$) is within the tolerances given in 5.3 (see Note 15).

10.2.3 Ensure that the bore of the extrusion plastometer is properly aligned in the vertical direction (see Appendix X1).

10.2.4 Inspect the apparatus and die for cleanliness. If it is not clean, see 9.11 and Note 14.

10.2.5 Check the die bore diameter with appropriately sized no-go/go gages before beginning the test. Make frequent checks to determine whether the die diameter is within the tolerances given in 5.3 (see Note 15).

10.2.6 Verify that the temperature is stable and within $\pm 0.2^\circ\text{C}$ of the appropriate test temperature as specified in 5.5.1.

10.2.7 Insert the die and the piston. The temperature of the cylinder with the piston and die in place must be stable at the appropriate test temperature 15 min before testing is begun. When equipment is used repetitiously, it should not be necessary to heat the piston and die for 15 min.

10.2.8 Adjust the travel arm to 6.35 ± 0.25 mm for measuring materials with expected flow rates of up to 10 g/10 min or 25.40 ± 0.25 mm for measuring materials with expected flow rates of 10 g/10 min or higher.

NOTE 25—It has been found that for some materials the melt flow rates obtained on a material will be different depending on which timer length is chosen; therefore, it is important to adhere to the protocol in 10.2.8 to compare interlaboratory results.

10.2.9 Remove the piston and place it on an insulated surface. Charge the cylinder within 60 s with a weighted portion of the sample ~~according to~~ in accordance with the expected flow rate, as given in Table 2. Reinsert the piston and add weight.

10.2.10 Allow time for the material to soften and begin to melt, and then purge some material to a position such that subsequent travel of the piston will position the lower scribe mark at the reference start position 7.0 ± 0.5 min from the completion of the charge. Purge must be completed at least 2 min prior to start of the test for materials having melt flow rates less than 10 g/10 min (see Note 19).

10.2.11 Weight and piston support, if needed, must be used after the initial purge. The support will be removed at such a time as to allow the timer to activate within 7.0 ± 0.5 min after completion of the charge. If the timer is not activated within 7 ± 0.5 min after the completion of the charge, the test must be repeated with readjusted piston position after the initial purge, or change weights. The piston/weight support should be of such a length that the lower scribe mark of the supported piston/weight will be at least 25 mm above the top of the cylinder. Only use piston support if there is excessive material flow (see Notes 22 and 23).

10.2.12 For materials greater than 50 g/10 min a die plug must be used in addition to the piston/weight support. The die plug is inserted before charge and is removed prior to removing the piston/weight support. The initial charge should be adjusted to

TABLE 3 Factors for Calculation of Flow Rate

| Material (Unpigmented) | Temperature, °C | Piston Travel, L, cm-[in.] | Factor for Calculation of Flow Rate, F ^A |
|---------------------------|-----------------|-------------------------------|---|
| Polyethylene | 490 | 2.54 (+) | 826 |
| Polyethylene | 190 | 2.54 [1] | 826 |
| Polyethylene | 490 | 0.635 (0.25) | 207 |
| Polyethylene | 190 | 0.635 [0.25] | 207 |
| Polypropylene | 230 | 2.54 (+) | 799 |
| Polypropylene | 230 | 2.54 [1] | 799 |
| Polypropylene | 230 | 0.635 (0.25) | 200 |
| Polypropylene | 230 | 0.635 [0.25] | 200 |

^A Factors calculated using melt-density values of 0.7636 g/cm³ for polyethylene and 0.7386 g/cm³ for polypropylene, as expressed in article by Zoller, Paul, "The Pressure-Volume-Temperature Properties of Polyolefins," *Journal of Applied Polymer Science*, Vol 23, 1979, P. 1051. The base densities at 23°C for which the melt densities are reported were 0.917 g/dm³ for annealed low-density polyethylene and polypropylene homopolymer.

reduce excess flow. If the timer arm is not activated within 7 ± 0.5 min after the completion of the charge the test must be repeated with readjusted piston position, or change weights (see Notes 22 and 23). **Warning**—Rapid expulsion of material when die plug is removed may be hazardous.

NOTE 26—~~Warning: Rapid expulsion of material when die plug is removed may be hazardous.~~

10.2.13 If the timed extrudate contains visible bubbles, repeat the test (see Note 24).

10.2.14 Record the time to the nearest 0.01 s for the piston to complete the calibrated distance of travel.

10.2.15 Discharge any remaining resin and clean the die, piston, and cylinder as detailed in 9.11.

11. Procedure C—Automatically Timed Flow Rate Measurement for High Flow Rate Polyolefins Using Half-Height, Half Diameter Die

11.1 Apparatus:

11.1.1 Extrusion plastometer and auxiliary equipment are detailed in Sections 5 and 10.

11.1.2 For polyolefins with a MFR of 75 or greater using the standard die (See 5.3), an alternate die can be used to reduce the flow rate of these materials and improve the reproducibility of results. The alternate die dimensions shall be: Height 3.985 ± 0.025 mm; bore diameter 1.048 ± 0.005 mm. No spacer shall be used with this die. Bore and finish requirements are the same as 5.3.

11.1.3 For calibration of the temperature indicating device, 5.5.2 shall be used with the variation that temperatures are measured at 14 ± 1 mm and at a nominal 79 mm above the upper surface of the die.

11.1.4 If a thermometer as described in 5.7 is used to indicate temperature, it can be used to monitor indirectly the temperature of the material 14 mm above the upper surface of the die and may be calibrated via 11.1.3.

11.2 Procedure:

11.2.1 Use procedure described in 10.2 with the exception that the die diameter and tolerances are given in 11.1.2.

12. Calculation (Procedures B and C)

12.1 Calculate the flow rate in grams per 10 min or volume rate in cm^3 per 10 min as follows (see Note 24):

$$\text{Flow rate} = (426 \times L \times d)/t$$

or

$$\text{Volume rate} = 426 \times L/t$$

where:

L = length of calibrated piston travel, cm,

d = density of resin at test temperature, g/cm^3 (see reference under Table 2),

t = time of piston travel for length L , s, and

426 = mean of areas of piston and cylinder $\times 600$.

NOTE 27—Factors that may be substituted in the following equation are given for some materials in Table 3.

$$\text{Flow rate, g/10 min} = F/t$$

where:

F = factor from Table 3, and

t = time of piston travel for length L , s.

12.2 Agreement between Procedures A and B may be optimized if an average melt density for a particular type of material is determined with the actual equipment used and that value is substituted into the equation given in 12.1.

13. Report

13.1 Report the following information:

13.1.1 Statement indicating the nature and physical form of the material charged to the cylinder.

13.1.2 Temperature and load at which the test is run shall be reported. The results and test conditions can be referred to as FR-condition, where the standard designation for the condition from Table 1 is shown (for example: FR-190/2.16).

NOTE 28—It has become customary to refer to the flow rate of polyethylene as “melt index” when obtained under Condition 190/2.16. However, for all other materials the use of melt index or any term other than “flow rate” is discouraged, regardless of the condition used.

13.1.3 Flow rate reported as the rate of extrusion in grams per 10 min or volume rate in cm^3 per 10 min.

13.1.4 Procedure used (A, B, or C).

13.1.5 Any unusual behavior of the test specimen such as discoloration, sticking, extrudate surface irregularity or roughness, etc.

13.1.6 Details of conditioning, if any.

14. Precision and Bias (Procedures A, B, and C)

14.1 Precision:

TABLE 4 Precision, Procedure A (Values in g/10 min)

| Material | Condition | Average | S_r^A | S_R^B | I_r^C | I_R^D | Number of Laboratories |
|---------------|-----------|---------|---------|---------|---------|---------|------------------------|
| Polyethylene | 190/2.16 | 0.27 | 0.008 | 0.022 | 0.023 | 0.063 | 9 |
| Polyethylene | 190/2.16 | 0.40 | 0.012 | 0.038 | 0.035 | 0.108 | 9 |
| Polyethylene | 190/2.16 | 2.04 | 0.026 | 0.079 | 0.073 | 0.224 | 9 |
| Polyethylene | 190/2.16 | 44.1 | 0.919 | 1.232 | 2.560 | 3.486 | 7 |
| Polypropylene | 230/2.16 | 2.23 | 0.106 | 0.226 | 0.299 | 0.639 | 9 |
| Polypropylene | 230/2.16 | 7.09 | 0.222 | 0.471 | 0.627 | 1.331 | 9 |
| Polypropylene | 230/2.16 | 32.8 | 0.581 | 1.051 | 1.644 | 2.974 | 9 |
| Polystyrene | 200/5 | 1.67 | 0.024 | 0.122 | 0.068 | 0.344 | 6 |
| Polystyrene | 200/5 | 8.82 | 0.190 | 0.667 | 0.538 | 1.886 | 6 |
| Polystyrene | 200/5 | 13.3 | 0.305 | 0.925 | 0.864 | 2.617 | 6 |
| Polycarbonate | 300/1.2 | 2.41 | 0.076 | 0.115 | 0.215 | 0.326 | 4 |
| Polycarbonate | 300/1.2 | 10.5 | 0.429 | 0.647 | 1.215 | 1.830 | 4 |
| Polycarbonate | 300/1.2 | 16.2 | 0.155 | 1.109 | 0.438 | 3.140 | 4 |
| Acrylic | 230/3.8 | 2.59 | 0.051 | 0.051 | 0.145 | 0.145 | 3 |

^A S_r = within-laboratory standard deviation of the average.

^B S_R = between-laboratories standard deviation of the average.

^C I_r = 2.83 S_r , and

^D I_R = 2.83 S_R .

TABLE 5 Precision, Procedure B (Values in g/10 min)

| Material | Condition | Average | S_r^A | S_R^B | I_r^C | I_R^D | Number of Laboratories |
|---------------|-----------|---------|---------|---------|---------|---------|------------------------|
| Polyethylene | 190/2.16 | 0.27 | 0.009 | 0.014 | 0.026 | 0.039 | 8 |
| Polyethylene | 190/2.16 | 0.40 | 0.016 | 0.027 | 0.045 | 0.076 | 8 |
| Polyethylene | 190/2.16 | 2.04 | 0.040 | 0.094 | 0.112 | 0.266 | 9 |
| Polyethylene | 190/2.16 | 43.7 | 0.997 | 1.924 | 2.819 | 5.443 | 8 |
| Polypropylene | 230/2.16 | 2.25 | 0.052 | 0.214 | 0.1466 | 0.604 | 8 |
| Polypropylene | 230/2.16 | 7.16 | 0.143 | 0.589 | 0.4051 | 1.666 | 8 |
| Polypropylene | 230/2.16 | 32.6 | 0.693 | 0.945 | 1.959 | 2.672 | 8 |
| Polystyrene | 200/5 | 1.65 | 0.037 | 0.166 | 0.106 | 0.470 | 4 |
| Polystyrene | 200/5 | 8.39 | 0.144 | 0.423 | 0.406 | 1.197 | 4 |
| Polystyrene | 200/5 | 13.0 | 0.108 | 0.387 | 0.306 | 1.097 | 4 |

^A S_r = within-laboratory standard deviation of the average.

^B S_R = between-laboratories standard deviation of the average.

^C I_r = 2.83 S_r , and

^D I_R = 2.83 S_R .

TABLE 6 Precision, Procedure A (Values in g/10 min)

| Material | Condition | Average | S_r^A | S_R^B | I_r^C | R^D | Number of Labs |
|---------------|-----------|---------|---------|---------|---------|-------|----------------|
| PMMA | 230/3.8 | 1.51 | 0.013 | 0.086 | 0.037 | 0.242 | 7 |
| LDPE | 190/2.16 | 1.74 | 0.027 | 0.052 | 0.075 | 0.144 | 11 |
| Polystyrene | 200/5.0 | 1.86 | 0.040 | 0.085 | 0.112 | 0.238 | 9 |
| HDPE | 190/2.16 | 5.35 | 0.049 | 0.103 | 0.137 | 0.288 | 11 |
| Polypropylene | 230/2.16 | 10.94 | 0.088 | 0.473 | 0.247 | 1.324 | 10 |
| Polycarbonate | 300/1.2 | 13.59 | 0.109 | 0.233 | 0.305 | 0.653 | 4 ^E |
| Acetal | 190/2.16 | 25.30 | 0.235 | 0.571 | 0.658 | 1.599 | 7 |

^A S_r = within-laboratory standard deviation of the average.

^B S_R = between-laboratories standard deviation of the average.

^C I_r = 2.83 S_r .

^D R = 2.83 S_R .

^E Insufficient laboratories to meet Practice E 691.

14.1.1 Tables 4 and 5 are based on a round robin⁶ conducted in 1986 and 1987, involving polypropylene, polyethylene, polystyrene, polycarbonate and acrylic materials. Tables 6 and 7 are based on a round robin⁷ completed in 1997 involving low and high density polyethylene, polypropylene, polystyrene, polycarbonate, PMMA, and acetal. The number of participating laboratories is shown for each material. Data for Tables 4 and 5 were generated through each lab testing two specimens for each material on three different days, while data for Tables 6 and 7 were generated through each lab testing two specimens for each material on two different days. The analysis in Practice E 691 is based on a test result being the average of two specimens.

⁶ These standard polyethylenes

⁶ Supporting data are available from the National Institute of Standards and Technology, Office of Standard Reference Materials, Washington, DC 20234. ASTM Headquarters. Request RR: D20-1164.

⁷ Supporting data are available from ASTM Headquarters. Request RR: D20-1164.

TABLE 7 Precision, Procedure B (Values in g/10 min)

| Material | Condition | Average | S_r^A | S_R^B | r^C | R^D | Number of Labs |
|---------------|-----------|---------|---------|---------|-------|-------|----------------|
| PMMA | 230/3.8 | 1.54 | 0.026 | 0.102 | 0.072 | 0.286 | 6 |
| LDPE | 190/2.16 | 1.76 | 0.015 | 0.053 | 0.042 | 0.149 | 11 |
| Polystyrene | 200/5.0 | 1.89 | 0.042 | 0.102 | 0.117 | 0.285 | 7 |
| HDPE | 190/2.16 | 5.41 | 0.041 | 0.113 | 0.114 | 0.316 | 10 |
| Polypropylene | 230/2.16 | 10.96 | 0.357 | 0.491 | 0.999 | 1.376 | 10 |
| Polycarbonate | 300/1.2 | 13.79 | 0.104 | 0.477 | 0.292 | 1.335 | 3 ^E |
| Acetal | 190/2.16 | 25.64 | 0.182 | 0.822 | 0.508 | 2.302 | 6 |

^A S_r = within-laboratory standard deviation of the average.

^B S_R = between-laboratories standard deviation of the average.

^C $r = 2.83 S_r$.

^D $R = 2.83 S_R$.

^E Insufficient laboratories to meet Practice E 691.

TABLE 8 Precision, Procedure B (Values in g/10 min)

| Material | Condition | Average | S_r^A | S_R^B | I_r^C | I_R^D |
|---------------|-----------|---------|---------|---------|---------|---------|
| Polypropylene | 230/2.16 | 245 | 13.2 | 16.6 | 37.4 | 46.9 |
| Polypropylene | 230/2.16 | 482 | 31.8 | 40.0 | 89.9 | 113 |
| Polypropylene | 230/2.16 | 837 | 20.9 | 58.6 | 59.1 | 166 |
| Polypropylene | 230/2.16 | 1603 | 129 | 243 | 365 | 688 |

^A S_r = within-laboratory standard deviation of the average.

^B S_R = between-laboratories standard deviation of the average.

^C $I_r = 2.83 S_r$ and

^D $I_R = 2.83 S_R$.

14.1.2 Table 8 is based on a round robin⁸ conducted in 1980 using Procedure B. Four polypropylene samples having flow rates from 250 to 1500 were tested in 9 laboratories.

NOTE 29—Caution: The nine laboratories. **Warning—**The following explanations of I_r and I_R (14.1.4-14.1.6) are only intended to present a meaningful way of considering the approximate precision of this test method. The data in Tables 4-8 should not be vigorously applied to acceptance or rejection of material since those data are specific to the round robin and may not be representative of other lots, conditions, materials or laboratories. Users of this test method should apply the principles outlined in Practice E 691 to generate data specific to their laboratory and materials. The principles of 14.1.4-14.1.7 would then be valid for such data.

NOTE 29—Caution:

14.1.3 Table 9 is based on a round robin conducted in 1999 on Procedure C. Data for seven of the eight participating laboratories were included in the statistics for this table. Four polyethylene materials were tested with melt flow rates using the standard die ranging from approximately 35 to 2350 g/10 min using the half-height, half-diameter die.

14.1.4 *Concept of I_r and I_R* —Relevant if S_r and S_R have been calculated from a large enough body of data, and if test results are averages obtained from testing two specimens.

14.1.5 *Repeatability, I_r* —In comparing two test results for the same material, obtained by the same operator using the same equipment on the same day, the two test results should be judged not equivalent if they differ by more than the I_r value for that material.

14.1.6 *Reproducibility, I_R* —In comparing two test results for the same material, obtained by different operators using different equipment on different days, the two test results should be judged not equivalent if they differ by more than the I_R value for that material.

14.1.7 Any judgment in accordance with 14.1.4 and 14.1.6 would have an approximate 95 % (0.95) probability of being correct.

14.2 *Bias*—There are no recognized standards by which to estimate bias of this test method.

⁸ Supporting data are available from ASTM Headquarters. Request RR: D20-1124.

**TABLE 9 Precision Data for High Melt Flow Polyolefins
Procedure C (Values in g/10 min)**

| Materials ^A | Average | S_r | S_R | r | R |
|------------------------|---------|-------|-------|-------|-------|
| Materials ^A | Average | S_r | S_R | r | R |
| PE-A (35) | 4.67 | 0.068 | 0.119 | 0.191 | 0.334 |
| PE-B (185) | 24.30 | 0.688 | 1.168 | 1.928 | 3.270 |
| PE-C (2350) | 315.7 | 10.81 | 19.89 | 30.27 | 55.69 |
| PE-D (122) | 16.20 | 0.188 | 0.348 | 0.526 | 0.975 |

^ANumbers in parentheses are approximate melt flow rate values of materials using standard die (5.3).

15. Keywords

15.1 melt flow rate; melt index; volume flow rate

APPENDIXES

(Nonmandatory Information)

X1. EXTRUSION PLASTOMETER BORE ALIGNMENT

X1.1 A fixture consisting of a circular level mounted on a shaft having two bearing points $9.47 + 0.00 - 0.0076$ mm in diameter that can be inserted into the bore has been found suitable. A circular level that can be rigidly mounted on the piston rod for insertion into the bore may also be satisfactory. A circular level having a sensitivity of 20 min/2.5 mm has been found satisfactory. Other alignment techniques that give comparable alignment sensitivity would be considered satisfactory.

X2. TROUBLESHOOTING GUIDE

INTRODUCTION

Appendix X2 is offered in an effort to help a laboratory improve melt flow rate testing and to get to the root cause of problems which may be caused by equipment, environment, or testing technique. This guide is not meant to be an all-inclusive trouble-shooting check list, but merely tries to help users to evaluate testing to some degree.

X2.1 Basic Programs

X2.1.1 The following are basic programs in which all laboratories should participate:

X2.1.1.1 *Standard Reference Materials*—If available, SRMs can usually be obtained from NIST. These SRMs provide accurate information on the melt flow rate of these materials. However, these SRMs are expensive and are available for a very limited number of materials.

X2.1.1.2 *Internal Controls*—An internal control for each type of material should be set up. This involves setting aside enough material to last a long time (at least one year). These materials will have to be tested many times to establish statistical parameters. Each time an internal standard is run, the results should be plotted on a SQC chart so that any problems or trends can be detected quickly. A SQC chart should be set up for each extrusion plastometer in the laboratory. A replacement standard should be introduced before the old standard runs out and should be compared to the old standard to ensure that any shifts seen in the SQC chart are due to the material and not to the equipment.

X2.1.1.3 *Proficiency Tests*—Participation in proficiency test programs is important for demonstrating how the laboratory's results compare with other laboratories. Over a period of time, laboratory bias can be demonstrated, if bias exists.

X2.1.1.4 *ASTM Round Robins (Interlaboratory Tests)*—These programs are similar to proficiency test programs but are limited to only a few laboratories and a few materials. However, these programs do provide information on how well the laboratory performs the test.

X2.1.1.5 *Calibration, Verification, and Maintenance*—The extrusion plastometer should be calibrated. Proper maintenance of the instrument will help to ensure proper calibration.

(1) As a first step to obtaining reproducible results, operators should be well trained. Using internal standards can demonstrate that repeatable results can be provided. The operators should also understand the test and know what can affect the results.

(2) Before starting the test, the following should be verified:

- (a) The protocol is understood by the operator.
- (b) The barrel, piston, and die orifice have been properly cleaned.
- (c) The extrusion plastometer, including the piston and die, are at equilibrium at the proper temperature.
- (d) The extrusion plastometer is level.
- (e) A standard has been run and the results fall within established parameters.

(3) When a problem arises, the following questions should be asked:

- (a) Did anything unusual happen?
- (b) Does the extrudate contain air bubbles?
- (c) Were the proper weights applied?
- (d) Is the unit at the proper temperature?
- (e) Was the piston stored in the barrel?

- (f) Is the die damaged, that is, chipped?
- (g) Is the die bore worn, that is, the diameter is larger than the maximum specified?
- (h) Was the proper amount of material used?
- (i) Has the balance been properly calibrated?
- (j) Was the proper purge time used?
- (k) Was the plug pulled at the proper time?
- (l) Was the correct warm-up time used?
- (m) Was the barrel cleaned properly?
- (n) Is the piston rod straight?
- (o) Is the piston tip diameter OK?

X2.2 Understanding How Melt Flow Rate is Affected

X2.2.1 Levelness of the Instrument—The piston must be free to move in a vertical position. If the instrument is not level, the piston can be slowed by friction as it touches the side of the barrel. This will not only introduce an error into the results but may also scratch the barrel. The piston must move in an exact vertical plane, indicated by a small bubble level that should be placed on the top of the barrel or on the top of the piston when placed in the barrel. The level should be checked on a regular schedule.

X2.2.2 Die Orifice Diameter—An undersized die orifice (which can result from a buildup of residue) will cause low results. Conversely, an oversized orifice (which can result from wear) will cause high results. It is important that the die orifice be cleaned after each test and that the die orifice diameter be verified frequently using a calibrated go/no-go gage. Remember, the calibrated pin gage can also wear and the diameter should be verified regularly.

X2.2.3 Die Cleanliness—The die should be completely cleaned after each test. Any residue left in the orifice will eventually char and be very difficult, if not impossible, to clean. Buildup of material will reduce the diameter of the die and change the surface smoothness, resulting in erroneous results.

X2.2.4 Temperature in the Barrel—Melt flow rates are very dependent on temperature. The temperature within the barrel is the only important temperature. Temperature indicators must be calibrated to the temperature within the barrel. High flow rates will result from high temperatures and low flow rates from low temperatures. Defective heaters may be difficult to detect and can cause variable results.

X2.2.5 Preheat Time—Proper preheat time is required to allow the material in the barrel to fully melt and to come to temperature equilibrium throughout the barrel. If material is not fully melted, die plugging and low melt flow rates can result. If not at temperature equilibrium, the melt flow rate will change as the test is conducted.

X2.2.5.1 It is important that the die and piston be at temperature equilibrium with the rest of the system before any sample is introduced into the barrel. If the piston and die are not at temperature, the large mass of metal involved must be heated to temperature during testing and the energy required may not allow the polymer to reach thermal equilibrium. This can result in erroneous data.

X2.2.6 Barrel Condition—The barrel should be properly cleaned after each test. Failure to do so can result in contamination of the next sample, and buildup and degradation of material in the barrel, resulting in a decrease in the diameter of the barrel. This can cause friction with the piston tip resulting in low melt flow rates.

X2.2.6.1 Frequently overlooked is the condition of the barrel itself. In addition to being clean, the barrel wall must be smooth and of the proper diameter. The inside diameter of the barrel is as important as the diameter of the die orifice. The barrel diameter should be measured regularly, and changed if so indicated. The melt flow rate is a function of the fourth power of the barrel diameter.

X2.2.7 Piston Parameters—The diameter of the piston foot should be checked. If it is worn, material can flow back past the tip. This would result in erroneous data.

X2.2.7.1 The piston tip, or foot, is sometimes screwed into the end of the piston and can be changed easily. However, because it is easily unscrewed, it can work itself loose. The piston tip must be checked frequently and kept tightly screwed into the piston.

X2.2.7.2 Care must be taken not to bend a piston. Even a slight, almost non-detectable curvature in the piston can result in the force not being applied directly to the vertical position, resulting in excessive pressure on the wall of the barrel. This will cause low results and can also scratch the barrel wall.

X2.2.7.3 The piston has two reference marks. The lower scribe mark on the piston must be at the reference start position (top of the guide ring or barrel) at 7.0 ± 0.5 min, as stated in 9.8 and 10.2.10. Starting each test at a different position can give variable results.

X2.2.8 Sample Mass—Small variations in sample mass can cause significant variability in melt flow rates. Any balance used to weigh the sample should be calibrated and verified on a regular schedule.

X2.2.9 Moisture in Sample—Samples should be dried before testing. Some materials may be affected more than others by moisture. However, the presence of moisture during the test, in general, will affect the melt flow rates of most materials.

X2.2.10 Sample Purge Time—Purging material from the barrel before the actual test starts serves two primary functions: (1) to expel entrapped air or volatiles before applying the full test load, and (2) to move the lower scribe mark on the piston to the reference start position. For flow rate consistency, it is important that the extrudate be free of voids and that the test always starts

with the piston in the same position in the barrel. Whether in the extrudate for Procedure A or in the barrel for Procedure B, voids will affect test results.

X2.2.11 *Load Weight*— The actual weight (load) applied to the material during the test will affect the test results. Higher weights will produce higher results. The load weight, which includes the piston weight, should be verified at regular intervals.

X2.2.12 *Extrudate Cut Technique*—It is important that good extrudate cutting technique be developed. A sharp, clean tool should always be used for this operation. The timing of the cut is critical since a shorter than target cut time will produce low results and a longer than target cut time will give high results. The timing intervals should be verified with certified timers. When cut, the extrudate end should not be ragged or stringy. These variables, if not controlled, can cause poor reproducibility of test results.

X2.2.13 *Purging*—Purging the barrel between runs or when changing materials is sometimes necessary. Purging with the same material which will be tested after the purge is best. However, if for some reason another purge material is used, run the test material through the barrel before the actual test run in order to ensure that the purge material is no longer in the barrel.

X2.2.13.1 Purging does not replace cleaning. After purging, the equipment must be cleaned properly to avoid the effects of contamination, resin buildup, and so forth, as discussed previously.

X2.2.14 *Melt Density*— It is important that the correct melt density be used, that is, 0.7636 g/cm³ for PE at 190°C and 0.7386 g/cm³ for PP at 230°C. These values may be different for copolymers or when additives are incorporated into the resin. Small errors in these values can affect the end results. If not known, the melt density can be determined as described at the end of Footnote A of Table 2.

X2.2.15 *Piston (Flag) Travel Distance* —The setting of the proper piston travel distance (6.35 ± 0.25 mm for MFRs up to 10 g/10 min and 25.40 ± 0.25 mm for MFRs greater than 10 g/10 min) is important in Procedure B. The reproducibility of Procedure B is better if these parameters are strictly adhered to. A calibrated distance verification device will be required to maintain the proper piston travel.

X2.2.16 *Calculation Factors*—When trouble shooting, always check the calculations and the factors used.

X2.2.17 *Power (Electrical) Fluctuation* —Constant power (voltage) is important to maintain the temperature desired. Periodic changes in voltage will cause changes in the temperature of the unit, creating test values that fluctuate because of inconsistent sample temperatures. Though this is a rare situation, this fluctuation has been found to cause erratic test results.

REFERENCES

- (1) "Polyethylene Insulation and Sheathing for Electrical Cables," *Government Department Electrical Specification No. 27*, Great Britain, 1950.
- (2) Tordella, J. P., and Jolly, R. E., "Melt Flow of Polyethylene," *Modern Plastics*, Vol 31, No. 2, 1953, p. 146.
- (3) Dexter, F. D., "Plasticity Grading of Fluorothenes," *Modern Plastics*, Vol 30, No. 8, 1953, p. 125.
- (4) Harban, A. A., and McClamery, R. M., "Limitations on Measuring Melt Flow Rates of Polyethylene and Ethylene Copolymers by Extrusion Plastometer," *Materials Research and Standards*, Vol 3, No. 11, 1963, p. 906.
- (5) Rudin, A., and Schreiber, H. P., "Factors in Melt Indexing of Polyolefins," *SPE Journal*, Vol 20, No. 6, 1964, p. 533.

SUMMARY OF CHANGES

This section identifies the location of selected changes to this test method. For the convenience of the user, Committee D20 has highlighted those changes that may impact the use of this test method. This section may also include descriptions of the changes or reasons for the changes, or both.

~~D 1238-98:D 1238 – 04:~~

- (1) ~~Rev Editorially added sulfone plastic melt flow rate conditions as found in Specification I D 6394 for Sulfone Plastics (SP).~~
- (2) ~~Additional melt flow rate conditions for polyether sulfone and polyphenylsulfone placed in 8.2.~~

~~D 1238 – 01:~~

- (1) ~~Procedure C for high flow polyolefins including precision data for the procedure, as well as Table 9 in Section 14 was added.~~

~~D 1238 – 00:~~

- (1) ~~Added Appendix X2, Troubleshooting Guide.~~

~~D 1238-99:~~

- (1) ~~Revised title to include the word "melt."~~
- (2) ~~Added conditions for polycaprolactone to 8.2 and Table 1.~~
- (3) ~~In Note 21, replaced "melt indexer" with "extrusion plastometer."~~
- (4) ~~In Note 25, replaced incorrect reference to 10.2.9 with 10.2.8.~~
- (5) ~~Editorially corrected equation in Footnote A of Table 2.~~

~~D 1238 – 00:D 1238-98:~~

- (1) ~~Added Appendix X2, Troubleshooting Guide.~~

~~D-1238-01:~~

~~(I) Procedure C for high flow polyolefins including precision data for the procedure, as well as Table 9 in Section 14 was added.)~~ Revision to Section 14.

ASTM International takes no position respecting the validity of any patent rights asserted in connection with any item mentioned in this standard. Users of this standard are expressly advised that determination of the validity of any such patent rights, and the risk of infringement of such rights, are entirely their own responsibility.

This standard is subject to revision at any time by the responsible technical committee and must be reviewed every five years and if not revised, either reapproved or withdrawn. Your comments are invited either for revision of this standard or for additional standards and should be addressed to ASTM International Headquarters. Your comments will receive careful consideration at a meeting of the responsible technical committee, which you may attend. If you feel that your comments have not received a fair hearing you should make your views known to the ASTM Committee on Standards, at the address shown below.

This standard is copyrighted by ASTM International, 100 Barr Harbor Drive, PO Box C700, West Conshohocken, PA 19428-2959, United States. Individual reprints (single or multiple copies) of this standard may be obtained by contacting ASTM at the above address or at 610-832-9585 (phone), 610-832-9555 (fax), or service@astm.org (e-mail); or through the ASTM website (www.astm.org).