



Designation: D 1430 – 003

## Standard Classification System for Polychlorotrifluoroethylene (PCTFE) Plastics<sup>1</sup>

This standard is issued under the fixed designation D 1430; the number immediately following the designation indicates the year of original adoption or, in the case of revision, the year of last revision. A number in parentheses indicates the year of last reapproval. A superscript epsilon ( $\epsilon$ ) indicates an editorial change since the last revision or reapproval.

*This standard has been approved for use by agencies of the Department of Defense.*

### 1. Scope\*

1.1 This classification system covers polychlorotrifluoroethylene (PCTFE) plastics that consist of at least 90 % chlorotrifluoroethylene and are suitable for extrusion and for compression and injection molding. The remaining 10 % may include chemical modifications, such as co-monomers, but not colorants, fillers, plasticizers, or mechanical blends with other resins. This classification system does not cover recycled PCTFE materials.

1.2 The physical and electrical properties of parts molded or extruded from PCTFE molding compounds vary with the crystalline content obtained during processing and subsequent annealing. Accordingly, the numerical values listed in Table 1 apply only to the test specimens molded in accordance with Section 8. These values may not be applicable as design criteria to parts prepared and annealed under other conditions.

1.3 The values stated in SI units as detailed in IEEE/ASTM SI 10 are to be regarded as the standard. The values given in parentheses brackets are for information only.

1.4 The following precautionary statement pertains only to the test methods portion, Section 10, of this classification system: *This standard does not purport to address all of the safety concerns, if any, associated with its use. It is the responsibility of the user of this standard to establish appropriate safety and health practices and determine the applicability of regulatory limitations prior to use.*

NOTE 1—Although this classification system and ISO 12086-1 (1995) and ISO 12086-2 (1995) differ in approach or detail, data obtained using either are technically equivalent.

### 2. Referenced Documents

#### 2.1 ASTM Standards:

D 150 Test Methods for A-C Loss Characteristics and Permittivity (Dielectric Constant) of Solid Electrical Insulation<sup>2</sup>

<sup>1</sup> This classification system is under the jurisdiction of ASTM Committee D20 on Plastics and is the direct responsibility of Subcommittee D20.15 on Thermoplastic Materials (Section D20.15.12).

Current edition approved Nov. 10, 2000<sup>3</sup>. Published January 2001. September 2003. Originally published as D 1430 – 56 F, approved in 1956. Last previous edition approved in 2000 as D 1430 – 9500.

\*A Summary of Changes section appears at the end of this standard.

**TABLE 1 Requirements for PCTFE Molded Test Specimens**

Group	Class	Description	Grade	Properties							
				Specific Gravity, <sup>A</sup> 23/23°C	Zero Strength Time, s <sup>B</sup>	Deformation Under Load <sup>C,D</sup>	Melting Point, °C <sup>E</sup>	Dielectric Constant <sup>F</sup> , max		Dissipation Factor <sup>G</sup> , max	
								KhZ	MHz	KhZ	MHz
01 powder	4	homopolymer	4	2.10-2.12	100-199	40	210-220	2.70	2.50	0.030	0.012
	1	homopolymer	1	2.10-2.15	100-199	10	210-220	2.70	2.50	0.030	0.012
			2	2.10-2.12	200-299	40	210-220	2.70	2.50	0.030	0.012
			2	2.10-2.15	200-299	10	210-220	2.70	2.50	0.030	0.012
			3	2.10-2.12	300-450	40	210-220	2.70	2.50	0.030	0.012
			3	2.10-2.15	300-450	10	210-220	2.70	2.50	0.030	0.012
0											
02 pellet	2	modified									
	2	modified homopolymer	4	2.10-2.12	100-199	15	200-210	2.70	2.50	0.030	0.012
			1	2.10-2.12	100-199	15	200-210	2.70	2.50	0.030	0.012
			2	2.10-2.12	200-299	15	200-210	2.70	2.50	0.030	0.012
			2	2.10-2.12	200-299	15	200-210	2.70	2.50	0.030	0.012
			0								
3	copolymer	1	2.08-2.10	100-199	20	190-200	2.70	2.50	0.035	0.015	
		2	2.07-2.10	200-299	25	190-200	2.70	2.50	0.035	0.015	
		0									
00 Other	0	other									
	0	other									

<sup>A</sup>See 10.1.7.

<sup>B</sup>See 10.1.3.

<sup>C</sup>See 10.1.4.

<sup>D</sup>Maximum at 1112 N-(250 lbf), 24 h, 70°C, %.

<sup>E</sup>See 10.1.5.

<sup>F</sup>See 10.1.6.

<sup>G</sup>See 10.1.6.

D 618 Practice for Conditioning Plastics and Electrical Insulating Materials for Testing<sup>3</sup>

D 621 Test Methods for Deformation of Plastics Under Load<sup>4</sup>

D 792 Test Methods for Density and Specific Gravity (Relative Density) of Plastics by Displacement<sup>3</sup>

D 883 Terminology Relating to Plastics<sup>3</sup>

D 1600 Terminology for Abbreviated Terms Relating to Plastics<sup>3</sup>

D 2117 Test Method for Melting Point of Semicrystalline Polymers by the Hot Stage Microscopy Method<sup>5</sup>

D 3418 Test Method for Transition Temperatures of Polymers by ~~Thermal Analysis~~ Differential Scanning Calorimetry<sup>6</sup>

D 3892 Practice for Packaging/Packing of Plastics<sup>6</sup>

D 4591 Test Method for Determining Temperatures and Heats of Transitions of Fluoropolymers by Differential Scanning Calorimetry<sup>7</sup>

2.2 ISO Standard:<sup>8</sup>

ISO 12086-1 (1995) Plastics—Fluoropolymer Dispersions and Moulding and Extrusion Materials, Part 1

ISO 12086-2 (1995) Plastics—Fluoropolymer Dispersions and Moulding and Extrusion Materials, Part 2

### 3. Terminology

3.1 *Definitions*—Definitions of terms used in this classification system shall be in accordance with Terminology D 883.

3.1.1 *lot, n*—one production run or uniform blend of two or more production runs.

**D 4895**

3.2 *Definitions of Terms Specific to This Standard:*

3.2.1 *preforming, n*—a process to compress the material under pressure in a mold to form a preform.

3.2.2 *zero strength time (ZST), n*—time measured ~~according to~~ in accordance with Section 10 of this classification system to check the relative molecular weight of PCTFE material.

3.3 *Abbreviations:Abbreviations*—Abbreviated terms are in accordance with Terminology D 1600.

<sup>2</sup> Annual Book of ASTM Standards, Vol 10.01.

<sup>3</sup> Annual Book of ASTM Standards, Vol 08.01.

<sup>4</sup> These test methods were withdrawn with no replacement in 1994. Test Methods D 621 can be obtained from Global Engineering Documents, 15 Inverness Way East, Englewood, CO 80112.

<sup>5</sup> Discontinued; see 1993 Annual Book of ASTM Standards, Vol 08.01.

<sup>6</sup> Annual Book of ASTM Standards, Vol 08.02.

<sup>7</sup> Annual Book of ASTM Standards, Vol 08.03.

<sup>8</sup> Available from American National Standards Institute (ANSI), 25 W. 42nd St., 43rd Floor, New York, NY 10036.

#### 4. Classification

4.1 ~~The PCTFE materials in powders and pellets are classified into groups in accordance with their physical appearance; one group. The groups are further~~ group is subdivided into classes based on chemical composition. These classes are subdivided into grades as shown in the Basic Property Table (Table 1).

An example of this classification system is given as follows:

Group 01 = ~~powder~~

~~†~~ PCTFE

Class 1 = homopolymer

Grade 2 = having properties ~~in accordance with~~ per Table 1 (Grade 2)

4.1.1 To facilitate incorporation of future material the “other” category for group (00), class (0), and grade (0) are shown in Table 1.

#### 5. General Requirements

5.1 The molding or extrusion material shall be of uniform composition and so compounded as to conform to the requirements of this classification system.

#### 6. Detail Requirements

6.1 Test specimens prepared in accordance with Section 9 shall conform to the requirements prescribed for the particular type and grade in Table 1.

#### 7. Sampling

7.1 Sampling shall be statistically adequate to satisfy the requirements of 11.4.

#### 8. Number of Tests

8.1 One set of test specimens as prescribed in Section 9 shall be considered sufficient for testing each batch. The average result for the specimens tested shall conform to the requirements prescribed in this classification system.

#### 9. Specimen Preparation

9.1 Test specimens shall be cut from compression-molded sheets  $1.58 \pm 0.08$  mm ( $[0.062 \pm 0.003$  in.]) thick, prepared from the resins in the following manner:

9.1.1 *Preforming*—Powder resin shall be preformed prior to molding in the following way: Place  $30 \pm 0.5$  g of resin into a 57-mm ( $[2.25$ -in.]) diameter positive-pressure compression mold and compress the material at room temperature into a preform having a density of 1.4 to 1.5 g/cm<sup>3</sup>. A pressure of 68.9 MPa ( $[10\ 000$  psi]) will satisfactorily accomplish the densification.

9.1.2 *Molding*—Pelletized resin, granular resin, and preforms of powder resin shall be molded in the following way: Place the preform prepared in accordance with 9.1.1 or  $30 \pm 0.5$  g of pelletized or granular resin on a 0.63-mm ( $[0.025$ -in.]) thick chrome-plated metal plate and cover with a similar plate. Place spacers,  $1.91 \pm 0.03$  mm ( $[0.075 \pm 0.001$  in.]) thick, between the chrome-plated metal plates and far enough apart so that they do not interfere with the flow of the resin during molding. Place the plates, with spacers and resin in place, between the platens of the press, the platens having been heated to a surface temperature of  $265 \pm 5^\circ\text{C}$ . Close and continuously load the platens, following the rate of melting so that the plates reach the stops within 3 min after closing the press. Then apply sufficient pressure for 3 min more to mold a sheet of the required thickness. Immediately after completion of the pressing, relieve the load, remove the plates and plastic sheet together, and at once quench them in cold water ( $15 \pm 5^\circ\text{C}$ ) for 5 min, supporting the sandwich in a vertical position in the water. Then strip the  $1.58 \pm 0.08$ -mm ( $[0.062 \pm 0.003$ -in.]) thick sheet from the metal plates. This sheet will be approximately 75 cm<sup>2</sup>. Cut specimens from the center section of each sheet, discarding any imperfectly molded edges.

#### 10. Test Methods

10.1 The properties enumerated in this classification system shall be determined in accordance with the following test methods:

10.1.1 *Conditioning*—For those tests where conditioning is required, the molded test specimens shall be conditioned in accordance with Procedure A of Practice D 618.

10.1.2 *Test Conditions*—Tests shall be conducted in the standard laboratory atmosphere of  $23 \pm 2^\circ\text{C}$  ( $[73.4 \pm 3.6^\circ\text{F}]$ ) and  $50 \pm 5\%$  relative humidity unless otherwise specified in the test methods or in this classification system.

10.1.3 *Zero Strength Time (ZST)*—The zero strength time of PCTFE plastics shall be determined in accordance with the procedure described in the following paragraphs:

10.1.3.1 *Significance and Use*—Control of molecular weight of these polymers is necessary because the fabricating temperatures are very high and close to the point of rapid thermal degradation. The test for zero strength time is well suited to this type of control, as it is rapid, simple, and adaptable to semiautomatic operation, and for specific PCTFE resins correlates with molecular weight.

10.1.3.2 *Apparatus*—Cylindrical brass thermostat and accessory equipment as specified in Annex A1.

10.1.3.3 *Test Strip*—From the molded sheet prepared in accordance with Section 9 cut two strips 50 mm (2 in.) [2 in.] long, 4.8 mm ( $\frac{3}{16}$  in.) wide, and  $1.58 \pm 0.08$  mm ( $[0.062 \pm 0.003$  in.]) thick, using the sample cutter. With the notching punch make a V-notch in both sides of the strips approximately at the center line (equally distant from the ends of the 50-mm length) so that the notches are directly opposite each other. The cross-sectional width between the notches shall be  $1.19 \pm 0.03$  mm ( $[0.047 \pm 0.001$  in.]), and the sides of each notch shall form an angle of  $90 \pm 0.5^\circ$  with each other. Alternatively, cut and notch the test strips in one operation with a test specimen punch mounted in an arbor press. Dimensions of the finished test strip are shown in Fig. A1.1.

10.1.3.4 *Procedure*—Insert one end of each notched strip into a specimen holder (Fig. A1.1) and clip a weight of  $7.5 \pm 0.1$  g on the other end of the strip. The specimen holder and weight shall be at or near room temperature ( $23 \pm 10^\circ\text{C}$ ). Insert the weighted specimens into the furnaces, which shall be at a temperature of  $250 \pm 1^\circ\text{C}$ , and start the timers at the moment of insertion. As each specimen breaks and the attached weight drops through the bottom of the furnace, stop the corresponding timer. Record the time in seconds indicated on each timer. Take the average of these two readings as the zero strength time for the duplicate specimens. If the difference between the two measurements exceeds 10 % of the average, reject these readings and test a second pair of specimens.

10.1.3.5 *Precision and Bias*—The precision and bias data for this test method is to be determined.

10.1.4 *Deformation Under Load*—Test Method A of Test Methods D 621. With 1112-N ( $[250\text{-lbf}]$ ) load at  $70 \pm 1^\circ\text{C}$ , except that permissible deformations may exceed 25 %.

NOTE 2—Experimental data have shown that at 1112-N ( $[250\text{-lbf}]$ ) load and  $70^\circ\text{C}$ , the test for deformation under load is applicable for the purpose of classification to the materials described in this specification beyond 25 % deformation.

10.1.5 *Melting Point*—The melting point shall be determined either by optical microscopy (see Test Method D 2117) or differential scanning calorimetry (DSC) (see Test Method D 4591). Both test methods give equivalent melting points after each sample receives a similar cooling history from the melt. Since rapid cooling may give a poor birefringence signal (see Note 3, Test Method D 2117) and a broad, poorly defined melt temperature, a sufficiently slow cooling rate should be selected to give a sharp, well-defined melt temperature on reheating.

10.1.5.1 For optical microscopy (see Test Method D 2117), the sample shall be a portion of the compression-molded sheet prepared in accordance with the sampling section which has been remolded to a film 0.01 to 0.04 mm ( $[0.4$  to  $1.6$  mils]) thick between the chrome-plated metal plates in a press with platens heated to a surface temperature of  $265 \pm 5^\circ\text{C}$ .

10.1.5.2 For DSC measurements, the test procedure shall follow that of the procedure section of Test Method D 4591, with the exception that the reported melt temperature is that obtained upon reheating the sample after an initial melting and recrystallization. Since rapid cooling may give a broad, poorly defined melt temperature, a sufficiently slow cooling rate should be selected to give a sharp, well-defined temperature on reheating.

10.1.6 *Dissipation Factor and Dielectric Constant*—Test Methods D 150.

NOTE 3—A disk of approximately 50-mm (2-in.) [2-in.] diameter has been found satisfactory for the test.

10.1.7 *Specific Gravity*—Test Method A of Test Methods D 792. The liquid used shall be *n*-heptane. The average of the specific-gravity of three test specimens shall be reported.

## 11. Inspection and Certification

11.1 Inspection and certification of the material supplied with reference to a specification based on this classification system shall be for conformance to the requirements specified herein.

11.2 Lot-acceptance shall be the basis on which acceptance or rejection of the lot is made. The lot-acceptance inspection shall consist of particle size determination.

11.3 Periodic check inspection with reference to a specification based on this classification system shall consist of the tests for all requirements of the material under the specification. Inspection frequency shall be adequate to ensure the material is certifiable in accordance with 11.4.

11.4 Certification shall be that the material was manufactured by a process in statistical control, sampled, tested, and inspected in accordance with this classification system, and that the average values for the lot meet the requirements of the specification (line callout).

11.5 A report of test results shall be furnished when requested. The report shall consist of results of the lot-acceptance inspection for the shipment and the results of the most recent periodic-check inspection.

## 12. Packaging and Package Marking

12.1 The provisions of Practice D 3892 apply to packaging, packing, and marking of containers for plastic materials.

## 13. Keywords

13.1 fluoropolymers; PCTFE; polychlorotrifluoroethylene; zero strength time

A1. APPARATUS FOR ZERO STRENGTH TIME TEST

A1.1 Cylindrical Brass Thermostat

A1.1.1 A cylindrical brass thermostat, Fig. A1.1, 127 mm (5 in.) [5 in.] in length and 102 mm (4 in.) [4 in.] in diameter, containing two smooth straight holes 19 mm (3/4 in.) [3/4 in.] in diameter for the test specimens. The holes shall be bored parallel to the axis of the cylinder and shall have inside surfaces coated with a high-temperature black paint to provide a uniformly radiating surface. Two additional holes shall be provided: one, 6 mm (1/4 in.) [1/4 in.] in diameter and 76 mm (3 in.) [3 in.] deep, to hold a 76-mm immersion thermometer covering the range from -5 to +400°C; the other, 16 mm (5/8 in.) [5/8 in.] in diameter and 89 mm (3 1/2 in.) [3 1/2 in.] deep, to hold a bimetallic thermoregulator. The cylinder shall be covered with a suitable insulating material. Provision shall be made to heat the apparatus so that the temperature can be maintained at  $250 \pm 1^\circ\text{C}$ .

A1.2 Accessory Equipment

A1.2.1 A suitable timing mechanism, thermometer, specimen holders, clip-on weights, a cutting tool (a commercial belt cutter) for preparing specimens of proper dimensions, and a notching tool (hammer impact operated, spring retracted with positioning device for centering the test strip) for cutting a standard notch in the specimen. Alternatively, a steel rule-type die in the shape of the finished test specimen may be used.

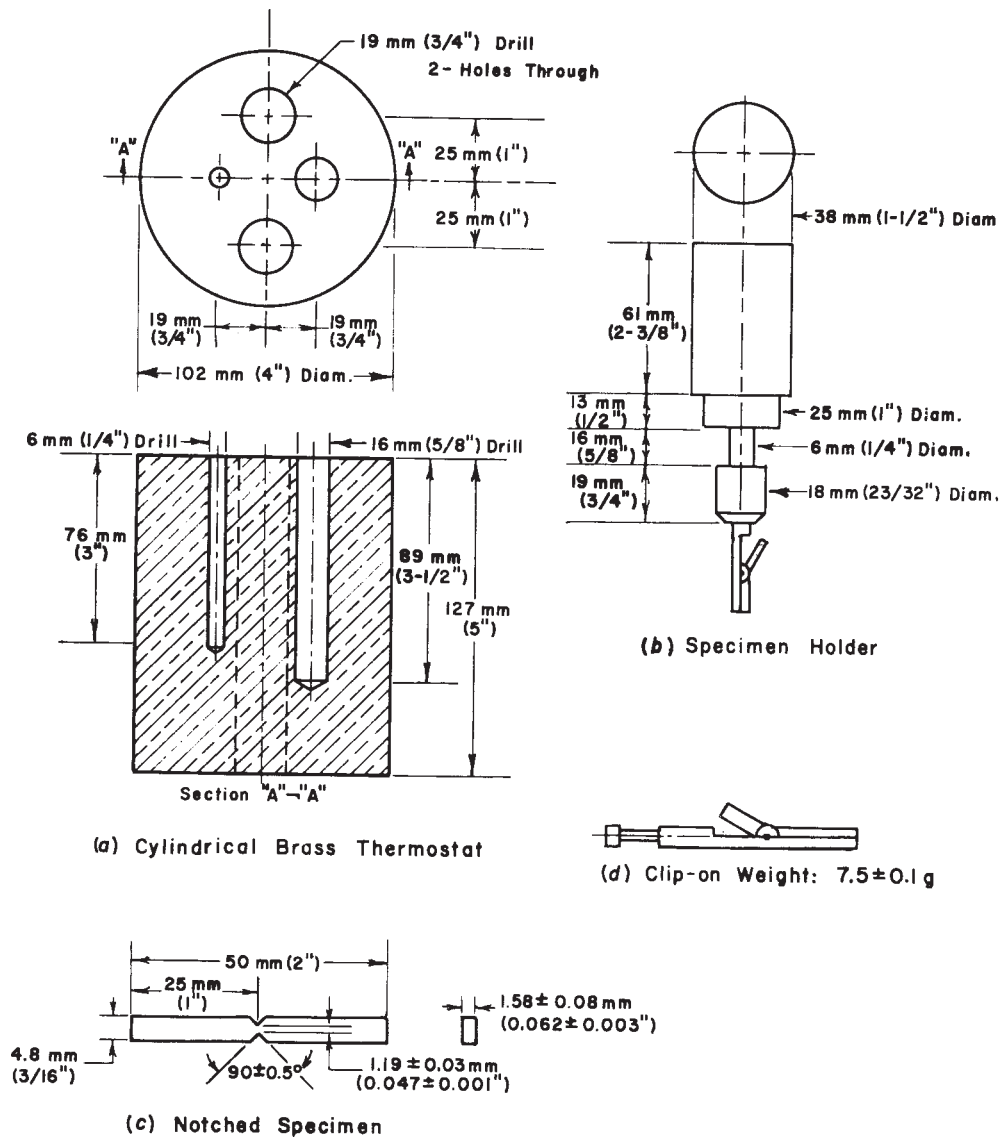

FIG. A1.1 Zero Strength Time Apparatus and Accessories

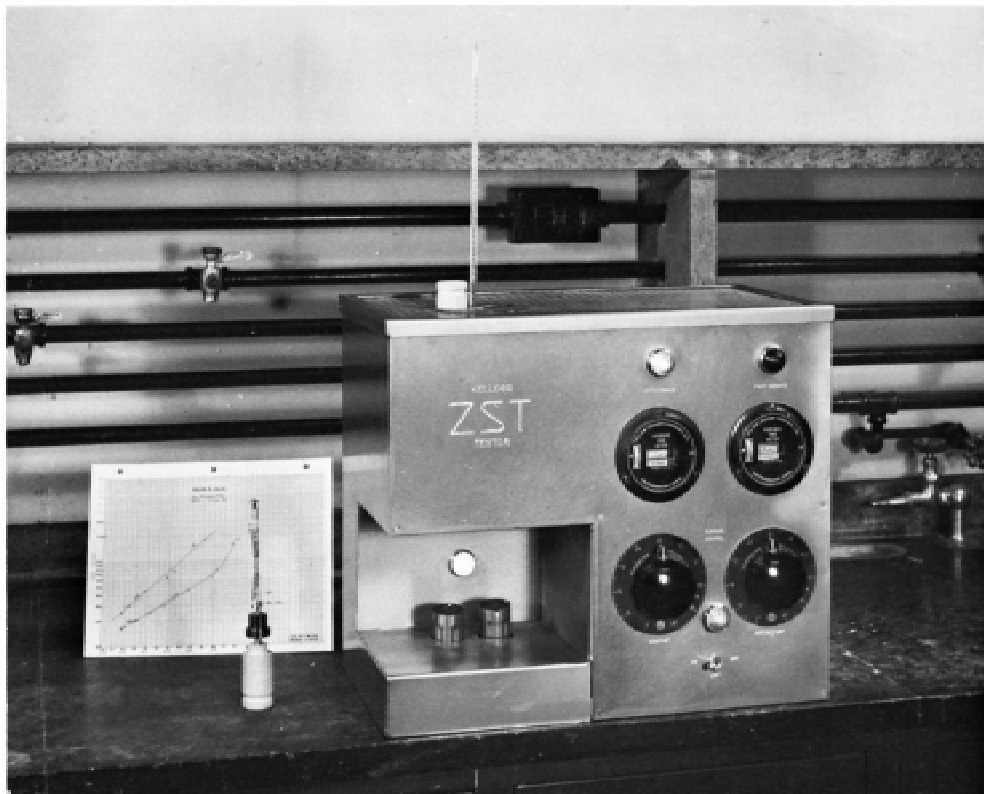

FIG. A1.2 Semiautomatic Instrument for Zero Strength Time Test

NOTE A1.1—The essential dimensions of the thermostat, specimen holders, specimen, and weights are shown in Fig. A1.1. A semiautomatic instrument conforming to the requirements of this test method is shown in Fig. A1.2.<sup>9</sup>

<sup>9</sup> One source of supply for this instrument is Custom Scientific Instruments, Inc., 13 Wing Drive, Cedar Knolls, NJ 07927.

## APPENDIX

(Nonmandatory Information)

### X1. REFERENCE TO PREVIOUS EDITIONS

#### INTRODUCTION

The classification system that was in Specification D 1430 – 95 and preceding editions is covered in this appendix to aid users in the transition to the Classification System D 4000 format. This appendix will be deleted in a period of time no longer than the next revision due in five years.

#### X1.1 Classification

X1.1.1 This appendix covers three types of PCTFE molding compounds in powder and pellet form classified according to in accordance with their chemical composition.

Homopolymer  
Modified homopolymer  
Copolymer

Type I  
Type II  
Type III

Type I has three grades, and Types II and III have two grades as indicated in Table X1.1. Each grade is representative of a

**TABLE X1.1 Requirements for PCTFE Molded Test Specimens**

	Type I Homopolymer			Type II Modified Homopolymer		Type III Copolymer	
	Grade 1	Grade 2	Grade 3	Grade 1	Grade 2	Grade 1	Grade 2
Specific gravity, 23/23°C [73.4/73.4°F]	2.10 to 2.12	2.10 to 2.12	2.10 to 2.12	2.10 to 2.12	2.10 to 2.12	2.08 to 2.10	2.07 to 2.10
Zero strength time, s	100 to 199	200 to 299	300 to 450	100 to 199	200 to 299	100 to 199	200 to 299
Deformation under load, max at 1112 N [250 lbf], 24, 70°C, %	10	10	10	15	15	20	
Melting point, °C	210 to 220	210 to 220	210 to 220	200 to 210	200 to 210	190 to 200	190 to 200
Dielectric constant, max:							
KHz	2.70	2.70	2.70	2.70	2.70	2.70	2.70
MHz	2.50	2.50	2.50	2.50	2.50	2.50	2.50
Dissipation factor, max:							
KHz	0.030	0.030	0.030	0.030	0.030	0.035	0.035
MHz	0.012	0.012	0.012	0.012	0.012	0.015	0.015

different range of apparent molecular weight.

### SUMMARY OF CHANGES

This section identifies the location of selected changes to this classification system. For the convenience of the user, Committee D20 has highlighted those changes that may impact the use of this classification system. This section may also include descriptions of the changes or reasons for the changes, or both.

#### D 1430 – 03:

- (1) Paragraph 4.1 was revised to show materials as one group including powders and pellets.
- (2) Changed groups to one group in Table 1.
- (3) Revised Specific Gravity of Group 01, Class 01, Grades 1, 2, and 3.

#### D 1430 – 00:

- (1) Changed title to reflect change in classification format, in accordance with Classification System D 4000.
- (2) Test Methods D 621, a withdrawn document essential to this classification system, is still referenced. Added instructions for availability in Footnote 4.
- (3) Deleted 3.2.1 and 3.2.2, 10.1.8, and reference to Test Methods D 1895 in 2.1.
- (4) Changed 3.3 to conform to the *ASTM Form and Style Manual*, Feb. 2000.
- (5) Deleted number 700 in 9.1.1.
- (6) Table 1—Deformation under load for old Type III, Grade 2, added at 25.
- (7) Placed Section 4, previous classification system, in Appendix X1. Renumbered sections throughout.

*ASTM International takes no position respecting the validity of any patent rights asserted in connection with any item mentioned in this standard. Users of this standard are expressly advised that determination of the validity of any such patent rights, and the risk of infringement of such rights, are entirely their own responsibility.*

*This standard is subject to revision at any time by the responsible technical committee and must be reviewed every five years and if not revised, either reapproved or withdrawn. Your comments are invited either for revision of this standard or for additional standards and should be addressed to ASTM International Headquarters. Your comments will receive careful consideration at a meeting of the responsible technical committee, which you may attend. If you feel that your comments have not received a fair hearing you should make your views known to the ASTM Committee on Standards, at the address shown below.*

*This standard is copyrighted by ASTM International, 100 Barr Harbor Drive, PO Box C700, West Conshohocken, PA 19428-2959, United States. Individual reprints (single or multiple copies) of this standard may be obtained by contacting ASTM at the above address or at 610-832-9585 (phone), 610-832-9555 (fax), or service@astm.org (e-mail); or through the ASTM website (www.astm.org).*