



Designation: D 2291 – 9803

Standard Practice for Fabrication of Ring Test Specimens for Glass-Resin Composites¹

This standard is issued under the fixed designation D 2291; the number immediately following the designation indicates the year of original adoption or, in the case of revision, the year of last revision. A number in parentheses indicates the year of last reapproval. A superscript epsilon (ϵ) indicates an editorial change since the last revision or reapproval.

1. Scope*

1.1 This practice is intended for use in the fabrication of ring-type test specimens to be used in the evaluation of the mechanical properties of reinforcement and resins in a composite structure. The practice outlines the steps in the preparation of the test specimens, including the final specimen machining where applicable. Four final ring configurations are included.

1.2 The values stated in either SI units or inch-pound units are to be regarded separately as the standard. The values stated in each system may not be exact equivalents; therefore, each system shall be used independently of the other. Combining values from the two systems may result in nonconformance with the standard.

1.3 *This standard does not purport to address all of the safety concerns, if any, associated with its use. It is the responsibility of the user of this standard to establish appropriate safety and health practices and determine the applicability of regulatory limitations prior to use.*

NOTE 1—There is no ISO equivalent to this standard.

¹ This practice is under the jurisdiction of ASTM Committee D-20 on Plastics and is the direct responsibility of Subcommittee D20.18 on Reinforced Thermosetting Plastics.

Current edition approved July 10, 1998; November 1, 2003. Published December 1998; January 2004. Originally published as D 2291 – 64 T, approved in 1964. Last previous edition D 2291 – 83 (1989)¹, approved in 1998 as D 2291 - 98.

*A Summary of Changes section appears at the end of this standard.

2. Referenced Documents

2.1 *ASTM Standards:*²

D 618 Practice for Conditioning Plastics and Electrical Insulating Materials for Testing

D 2290 Test Method for Apparent Hoop Tensile Strength of Ring Plastic or Tubular Plastics and Reinforced Plastics Pipe by Split Disk Method

D 2344 Test Method for Apparent Interlaminar Shear Short-Beam Strength of Parallel Fiber Composites by Short-Beam Method³ Polymer Matrix Composite Materials and Their Laminates

3. Terminology

3.1 For definitions of terms which apply to this practice, see Terminology D 883.

4. Significance and Use

4.1 This practice provides a uniform procedure for fabricating glass fiber/thermoset resin ring samples for use as test specimens. Specimens so prepared can be used in Test Methods D 2290 and in D 2344.

5. Apparatus

5.1 *Winding Machine*— The winding machine may consist of any adequate superstructure for mounting impregnated reinforcement or components for application of resin to the reinforcement, tensioning the reinforcement, and collecting the wetted, tensioned material on a mold or mandrel of the desired size.

5.2 *Tension Measuring System*—Any device suitable for measurement of the tension applied to the wetted reinforcement. The device shall be capable of measuring the tension accurately to within $\pm 5\%$.

5.3 The single-ring fabrication mold on which the wetted reinforcement is collected shall be constructed as shown in Fig. 1. For cylinder fabrication from which rings are to be cut, a mandrel with the proper diameter fitted to a suitable winding machine shall be used to collect the wetted reinforcement. The surfaces of the mold or mandrel that contact the ring specimens shall be coated or otherwise treated to prevent sticking of the ring or cylinder in the mold or on the mandrel.

5.4 *Curing Ovens*— Ovens having adequate range in temperature to produce a fully cured specimen shall be available for use. Control of the curing-postcuring temperatures to within $\pm 9^\circ\text{F}$ ($\pm 5^\circ\text{C}$) [$\pm 5^\circ\text{C}$] is required.

6. Storage and Conditioning of Components

6.1 Glass rovings and yarns for use in fabrication of ring test specimens shall be stored in a dry place, not subject to temperature extremes, or as specified by the glass producer. Prior to use, the rovings shall be conditioned in accordance with Procedure A of Practice D 618.

6.2 Resins to be used in the fabrication of ring test specimens shall be stored in closed containers at a temperature specified by the supplier. In addition, no resin shall be used that has been stored for a period in excess of the shelf life recommended by the supplier. Prior to fabrication of the test specimen, the resin shall be heated as necessary to provide sufficient lowering of the viscosity to produce good wetting of the reinforcement strand.

6.3 Preimpregnated materials received for the preparation of ring test specimens shall be stored in a closed container at a temperature as recommended by the supplier. Before winding, they shall be removed from storage and conditioned as recommended by the supplier or in accordance with Procedure A of Methods D 618.

7. Procedure for Dry Reinforcement

7.1 Fig. 2 is a schematic diagram of the system for wetting, tensioning, and collecting the reinforcement.

² For referenced ASTM standards, visit the ASTM website, www.astm.org, or contact ASTM Customer Service at service@astm.org. For Annual Book of ASTM Standards, Vol 08.01, Standards volume information, refer to the standard's Document Summary page on the ASTM website.

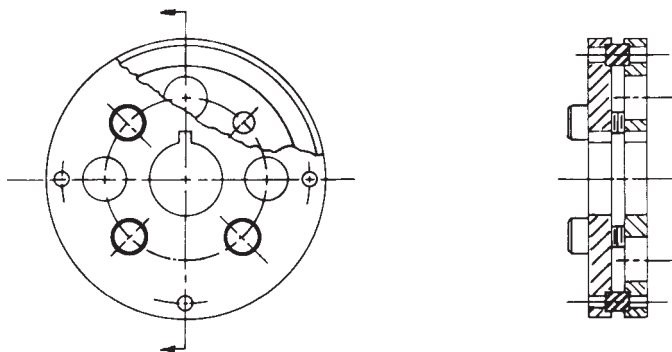

FIG. 1 Suggested Single-Ring Mold

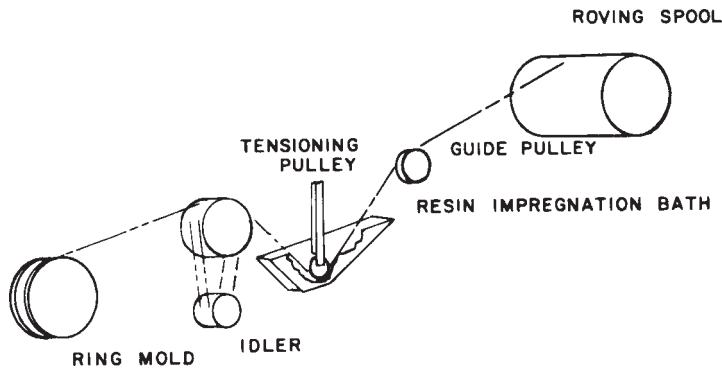

FIG. 2 Schematic Diagram of Wet Roving Ring Winding Apparatus

7.1.1 *Mounting Reinforcement Packages*—Mount the reinforcement package in a convenient location within the superstructure of the winding machine. Provide sufficient braking of the axle of the package to prevent free-wheeling. This should be a minimum tension.

7.1.2 *Application of Resin*—The reinforcement leaving the package shall pass immediately into the resin bath. Heat the resin bath sufficiently to lower the resin viscosity to a workable range. As the reinforcement is pulled from the resin bath, remove excess resin by any convenient method that results in a minimum amount of fraying or breakage of the reinforcement.

7.1.3 *Tensioning*—After leaving the resin bath, pass the reinforcement over a pulley or a series of pulleys, adequately braked to impart the desired tension to the fibers. The tension may be monitored, by any convenient method, either periodically or continuously during the winding operation. Limit the deviation from the mean tension to $\pm 5\%$ from start to finish of the winding of a test specimen. The diameter of the tension pulley(s) shall be a minimum of 3.0 in. $\{[76.2\text{ mm}]\}$. Larger sizes should be used when available. Take care that no slippage of the strand occurs over the pulley(s).

7.1.4 *Level-Winding*—Pass the wetted reinforcement through a level-winding guide and onto the mold. The guide shall be geared to the mold or mandrel or shall follow a cam in such a manner that each revolution of the mold or mandrel will be accompanied by a precision of the guide by an amount equivalent to one strand width.

7.1.5 *Collecting Reinforcement*—Collect the wetted reinforcement strand on a mold or mandrel that is mounted on the axle of a variable-speed drive. The strand velocity through the resin bath shall be constant and shall be slow enough to give good wetting of the reinforcement with the resin. Apply an adequate mold release agent to the mold or mandrel before winding is begun to assure easy removal of the specimen after fabrication. Wind specimens to be tested without machining the surface to a thickness as indicated for the Type B specimen, Fig. 3. Build up Types A, B, and C specimens in Fig. 3 to a thickness beyond that required

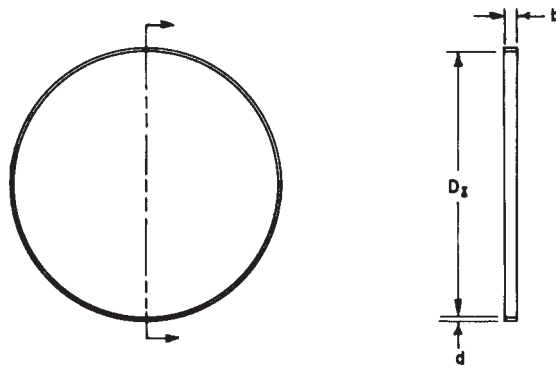

NOTE—

Type of Specimen	Inside Diameter, D_i		Width, b		Wall Thickness, d	
	in.	mm	in.	mm	in.	mm
A	5.750 ± 0.002	146.05 ± 0.05	0.250 ± 0.005	6.35 ± 0.127	0.060 ± 0.002	1.52 ± 0.05
B	5.750 ± 0.002	146.05 ± 0.05	0.250 ± 0.005	6.35 ± 0.127	0.060 ± 0.010	1.52 ± 0.25
C	5.750 ± 0.002	146.05 ± 0.05	0.250 ± 0.005	6.35 ± 0.127	0.125 ± 0.002	3.18 ± 0.05

FIG. 3 Ring Test Specimen

for finished thickness. Upon completion of the winding process, secure the strand in such a manner as to retain the tension before cutting the strand and removing the mold or mandrel from the winding machine.

7.1.6 *Curing*—Transfer the molds or mandrel to an oven and polymerize the resin in the manner prescribed by the manufacturer.

NOTE 2—Excess resin on the surface of the Type B specimen should be removed if possible during cure.

NOTE 3—Many fabricating factors influence the mechanical properties of the rings such as the equipment system, resin system and age, operator techniques, ambient conditions and conditioning, etc. For this reason it is best to run a control material with each set of samples and to randomize the fabrication order of the rings.

7.1.7 *Removing Rings from Mold or Mandrel*—Remove the ring specimens from the molds or mandrel in such a manner that delamination or other damage to the surfaces does not occur. An arbor press may be used to apply force to separate the mold parts in the single-ring process if required.

7.1.8 *Preparation of Specimens for Testing:*

7.1.8.1 *Width*—Mold or machine the width of the Type A, B, C, and D specimens to the correct width.

7.1.8.2 *Thickness*—Do not machine the thickness of the Type B specimens. Machine the thickness of the Types A, C, and D specimens to the correct wall thickness.

7.1.8.3 The dimensions of the finished test specimen are given in Fig. 3. Following the machining operation, the specimen may be submitted to test or may be cut into flexural or horizontal shear specimens as desired. When cutting these specimens from the ring, take care that all cut surfaces are parallel to the radius of the ring.

7.1.8.4 When fabricating composite specimens by machining operations, a fine dust consisting of particles of fibers or the matrix material, or both, may be formed. These fine dusts can be a serious health or safety hazard, or both. Adequate protection should be afforded operating personnel and equipment. This may require adequate ventilation or dust collecting facilities, or both, at a minimum.

8. Procedure for Prepregs

8.1 The procedure for the preparation of ring test specimens from preimpregnated material shall be identical to that described for dry roving, except omit 7.1.2 (see Fig. 4).

9. Report

9.1 The report shall include the following:

9.1.1 Complete identification of all components in the rings fabricated; including type, source, form of the resin system, reinforcement, or preimpregnated material. It shall also include the history of the material including, but not limited to, age and storage conditions,

9.1.2 Complete description of conditions under which the rings were fabricated, including temperature and relative humidity,

9.1.3 Complete description of the impregnation method,

9.1.4 Resin wiping technique,

9.1.5 Tension,

9.1.6 Rate of winding,

9.1.7 Any special equipment or methods utilized,

9.1.8 Type of specimen fabricated, single or cylinder,

9.1.9 Mold materials used,

9.1.10 Complete cure procedure, and

9.1.11 Date of fabrication.

10. Keywords

10.1 composite; glass fiber; prepreg; ring samples; ring tensile testing; shear testing; specimen preparation; thermoset resin

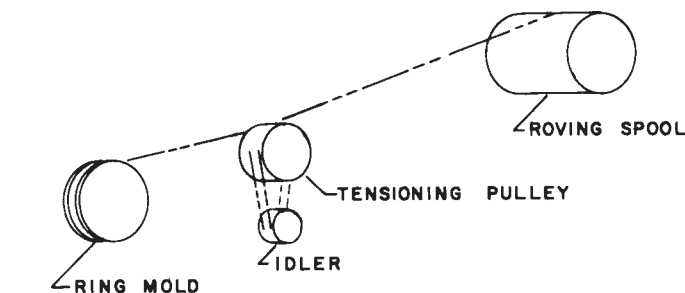

FIG. 4 Schematic Diagram of Preimpregnated Roving Winding System

SUMMARY OF CHANGES

~~Committee D-20 has identified~~

This section identifies the location of selected changes to this practice since practice. For the last issue convenience of the user, Committee D20 has highlighted those changes that may impact the use of this practice. This section may also include descriptions of the changes or reasons for the changes, or both.

D 2291 – 03:

(1) Revised paragraph 1.2.

D 2291 – 98:

- (1) Terminology, Significance and Use, and Keywords sections were added.
- (2) An ISO equivalency note was added to Section 1.
- (3) Test Methods D 2290 and D 2344 were added to 2.1.

ASTM International takes no position respecting the validity of any patent rights asserted in connection with any item mentioned in this standard. Users of this standard are expressly advised that determination of the validity of any such patent rights, and the risk of infringement of such rights, are entirely their own responsibility.

This standard is subject to revision at any time by the responsible technical committee and must be reviewed every five years and if not revised, either reapproved or withdrawn. Your comments are invited either for revision of this standard or for additional standards and should be addressed to ASTM International Headquarters. Your comments will receive careful consideration at a meeting of the responsible technical committee, which you may attend. If you feel that your comments have not received a fair hearing you should make your views known to the ASTM Committee on Standards, at the address shown below.

This standard is copyrighted by ASTM International, 100 Barr Harbor Drive, PO Box C700, West Conshohocken, PA 19428-2959, United States. Individual reprints (single or multiple copies) of this standard may be obtained by contacting ASTM at the above address or at 610-832-9585 (phone), 610-832-9555 (fax), or service@astm.org (e-mail); or through the ASTM website (www.astm.org).