



Designation: D 2732 – 9603

Standard Test Method for Unrestrained Linear Thermal Shrinkage of Plastic Film and Sheeting ¹

This standard is issued under the fixed designation D 2732; the number immediately following the designation indicates the year of original adoption or, in the case of revision, the year of last revision. A number in parentheses indicates the year of last reapproval. A superscript epsilon (ϵ) indicates an editorial change since the last revision or reapproval.

1. Scope*

1.1 This test method covers determination of the degree of unrestrained linear thermal shrinkage at given specimen temperatures of plastic film and sheeting of 0.76 mm (\approx [0.030 in.]) thickness or less. This test method does not cover shrinkage from loss of solvent in some materials.

1.2 *This standard does not purport to address all of the safety concerns, if any, associated with its use. It is the responsibility of the user of this standard to establish appropriate safety and health practices and determine the applicability of regulatory limitations prior to use.*

NOTE 1—This document is similar in concept not equivalent to ISO/DIS 11501, but it is unknown at this time whether both methods give comparable results. ISO 11501.

2. Referenced Documents

2.1 ASTM Standards:

¹ This test method is under the jurisdiction of ASTM Committee D-20 on Plastics and is the direct responsibility of Subcommittee D20.19 on Film and Sheeting . Current edition approved ~~Sept. August~~ 10, 1996; 2003. Published ~~February~~ 1997; October 2003. Originally published as D 2732 – 68 T; approved in 1968. Last previous edition ~~D 2732 – 83 (1989)~~¹.

~~This revision has incorporated an ISO equivalency statement, a revised precision and bias statement, keywords, and some of the note material has been included approved in the text.~~ 1996 as D 2732 – 96.

*A Summary of Changes section appears at the end of this standard.

D 618 Practice for Conditioning Plastics for Testing²

~~D 1204 Test Method for Linear Dimensional Changes of Nonrigid Thermoplastic Sheeting or Film at Elevated Temperature~~ 883 Terminology Relating to Plastics²

~~D 1898 Practice 1204 Test Method for Sampling Linear Dimensional Changes of P Nonrigid Thermoplastics Sheeting or Film at Elevated Temperature~~²

E 1 Specification for ASTM Thermometers³

2.2 ISO Standard:⁴

ISO 11501 Determination of Dimensional Change on Heating

3. Terminology

3.1 Definitions:

3.1.1 *unrestrained linear thermal shrinkage (free shrink or shrinkage)*—the irreversible and rapid reduction in linear dimension in a specified direction occurring in film subjected to elevated temperatures under conditions where nil or negligible restraint to inhibit shrinkage is present. It is normally expressed as a percentage of the original dimension.

4. Significance and Use

4.1 As a result of the manufacturing process, internal stresses may be locked into the film which can be released by heating. The temperature at which shrinkage will occur is related to the processing techniques employed to manufacture the film and may also be related to a phase transition in the base resin. The magnitude of the shrinkage will vary with the temperature of the film.

4.2 Shrinkage of a particular material produced by a particular process may be characterized by this test method by making measurements at several temperatures through the shrinkage range of the material.

4.3 Following a characterization in a particular case, it is usually sufficient thereafter to measure shrinkage at only one selected temperature for purposes of process or quality control, or both.

5. Apparatus

5.1 *Constant-Temperature Liquid Bath*, capable of controlling accurately to $\pm 0.5^\circ\text{C}$.

5.1.1 The liquid for the bath should not plasticize or react with the specimens. Poly(ethylene glycol), glycerin, and water have been found to have wide applicability.

5.2 *Thermometer*—ASTM Thermometer 1 C conforming to the requirements as prescribed in Specification E 1.

5.3 *Square Metal Stamp*, 100 by 100 mm, with engraved arrow indicating machine direction of film and stamp pad and ink. (The ink should not be soluble in the bath liquid.)

NOTE 2—A metal die or template (100 by 100 mm) can be used instead of the square metal stamp.

5.4 *Free Shrink Holder*—A holder designed for test of a single specimen, such as that shown in Fig. 1 and Fig. 2. Alternatively, a holder such as that shown in Fig. 3 may be used to immerse several specimens at a time. However, checks must be made to assure that contact among the specimens does not result in errors.

5.5 *Ruler*, graduated in millimetres.

6. Test Specimen

6.1 The test specimen shall consist of 100 by 100-mm samples.

6.2 A minimum of two specimens is necessary for each test temperature.

~~6.3 The material shall be sampled in accordance with Practice D 1898.~~

7. Conditioning

7.1 *Conditioning*—Condition the test specimens at $23 \pm 2^\circ\text{C}$ ($[73.4 \pm 3.6^\circ\text{F}]$) and $50 \pm 5\%$ relative humidity for not less than 40 h prior to test in accordance with Procedure A of Practice D 618, for those tests where conditioning is required. In cases of disagreement, the tolerances shall be $\pm 1^\circ\text{C}$ ($[\pm 1.8^\circ\text{F}]$) and $\pm 2\%$ relative humidity.

7.2 *Test Conditions*—Set the liquid bath temperature to within $\pm 0.5^\circ\text{C}$ of the desired temperature and allow to stabilize.

8. Procedure

8.1 Stamp and cut out the stamped section of film. A small border of film may be left around the stamped area.

8.1.1 As an alternative method, the specimens may be cut with a die or with the aid of a template. An edge of the die may be notched to designate film direction.

8.2 Place the specimen in a free shrink holder such that it is free from contact with the edges of the holder. The holder should restrain the specimen from floating in the bath medium while allowing free circulation of the bath medium around the specimen. Multiple specimens can be tested but care should be exercised to prevent restraint between the specimens.

² Annual Book of ASTM Standards, Vol 08.01.

³ Annual Book of ASTM Standards, Vol 14.03.

⁴ Available from American National Standards Institute (ANSI), 25 W. 43rd St., 4th Floor, New York, NY 10036.

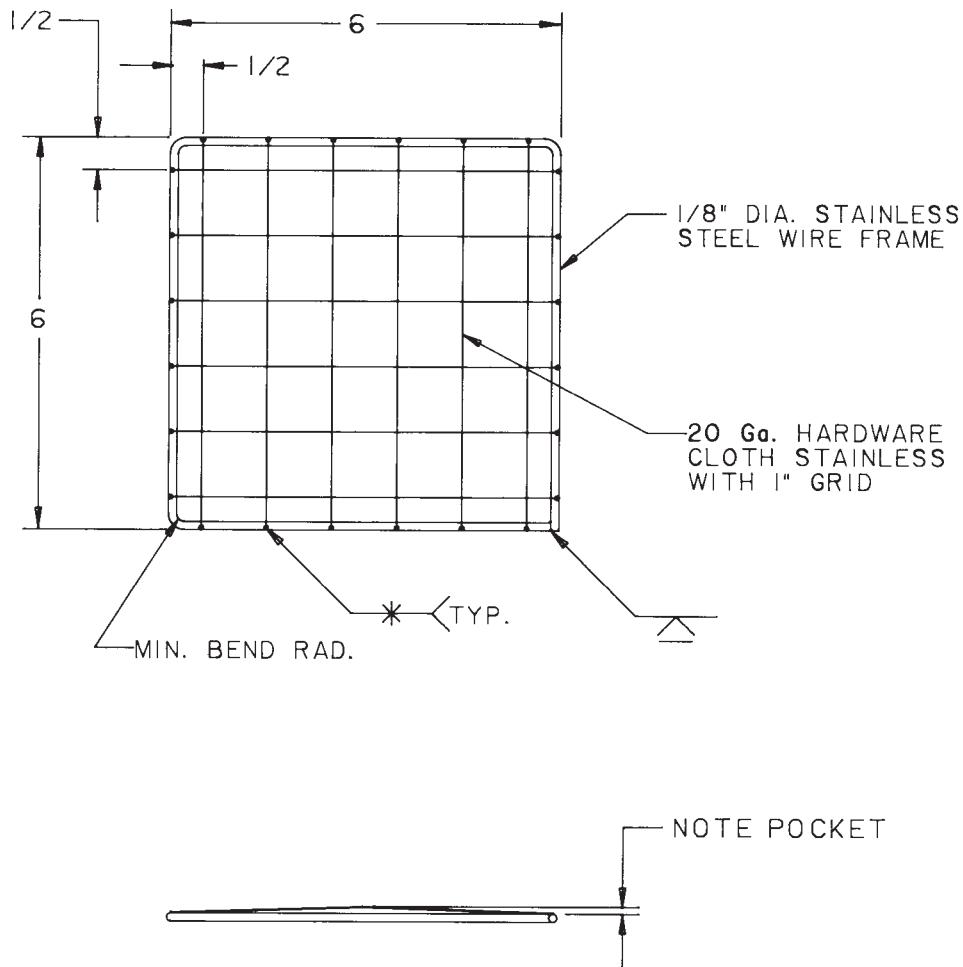

NOTE:

1. (A) Cut hardware cloth 6 7/8 by 6 7/8 .
- (B) Form a pocket in center of cloth.
- (C) Weld cloth to frame as shown.
2. Two required for assembly.

FIG. 1 Construction of Top and Bottom Grid Retainers of Specimen Holder

8.3 Observe and record the temperature of the bath before immersion of each specimen.

8.4 Immerse the specimen in the bath for 10 s or a time determined to be sufficient for the material to come to thermal equilibrium and undergo maximum shrinkage. Do not hold the specimen over the bath prior to immersion, as it may result in premature shrinkage or annealing, which may introduce an error.

NOTE 3—Immersion for 10 s has been determined to be generally adequate for most thermoplastics of up to 0.05 mm (0.002 in.) thickness; however, for new or thicker materials, a different time of immersion may be required to ensure maximum shrinkage at the temperature of interest.

8.5 Remove the specimen from the bath and quickly immerse in a liquid medium at room temperature preferably miscible with the bath medium.

8.6 After 5 s remove the specimen from the cooling medium and measure and record the linear dimensions of the specimen in both the machine (longitudinal) and transverse directions.

NOTE 4—**Caution:** Avoid stretching the specimen.

9. Calculation

9.1 Determine the percent free shrinkage for each direction as follows:

$$\text{Unrestrained linear shrinkage, \%} = [(L_0 - L_f)/L_0] \times 100 \quad (1)$$

where:

- L_0 = initial length of side (100 mm), and
 L_f = length of side after shrinking.

NOTE 5—If the material elongates, a negative number will result.

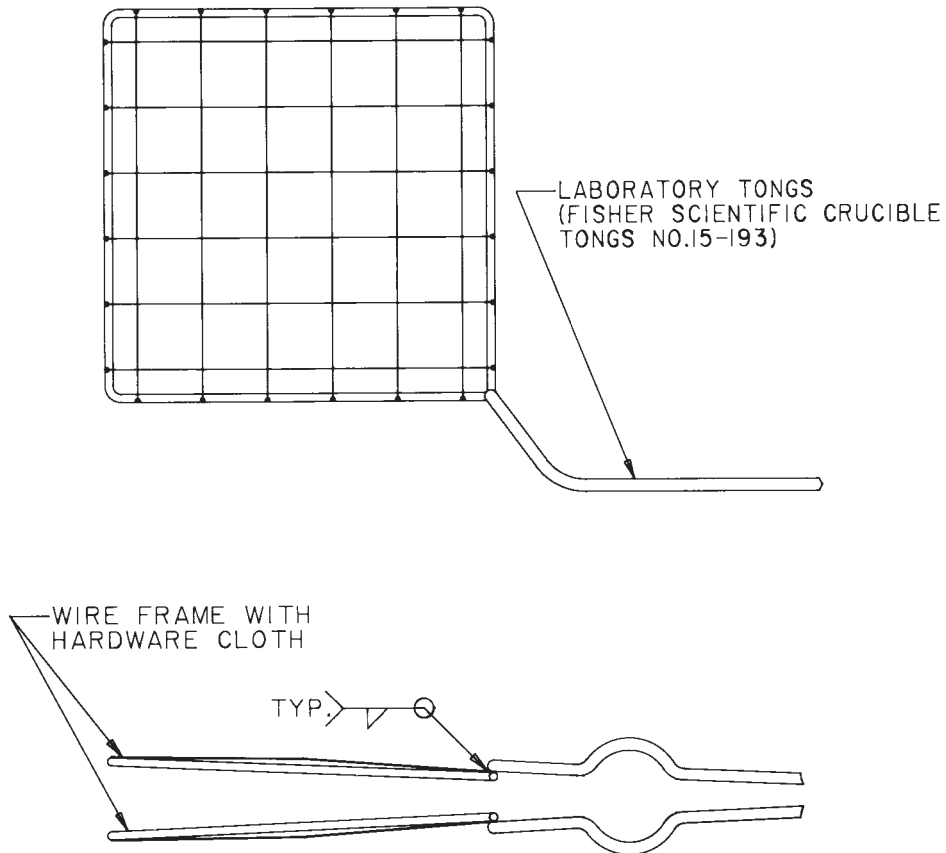

NOTE 1—Weld one wire frame to the inside of both arms of the tongs as shown.

FIG. 2 Assembly of Specimen Holder

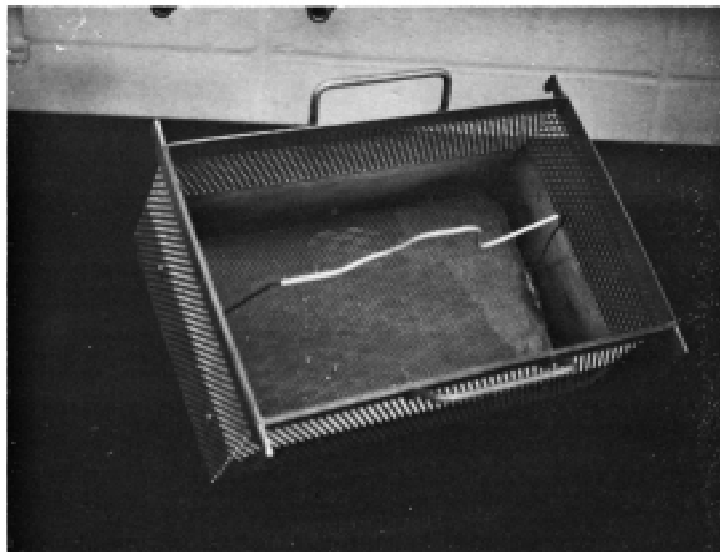

FIG. 3 Trough and Wire Basket

NOTE 6—Since the original dimension is exactly 100 mm, the shrinkage may be read directly from the rule by placing the 100-mm mark on one end of the line and reading millimetres opposite the other end of the line as the percent shrinkage.

9.2 *Sample Calculations:*

Initial length, $L_0 = 100$ mm (2)

Length after shrinkage, $L_f = 75$ mm (3)

Unrestrained linear shrinkage, % = $[(100 - 75)/100] \times 100 = 25$

(4)

10. Report

10.1 The report shall include the following:

- 10.1.1 Average percent linear free shrinkage in both directions, machine (longitudinal) and transverse,
- 10.1.2 Bath temperature,
- 10.1.3 Complete sample identification, and
- 10.1.4 Number of specimens tested.

11. Precision and Bias

11.1 *Precision*—Round-robin tests between five locations have shown good agreement by this procedure with reproducibility as shown in Fig. 4 and Fig. 5; however, the round-robin data is unavailable to calculate the parameters for a formal precision and bias statement.

11.2 *Bias*—There are no recognized standards by which to estimate the bias of this test method.

12. Keywords

- 12.1 free shrink; plastics; sheeting; unrestrained linear shrinkage

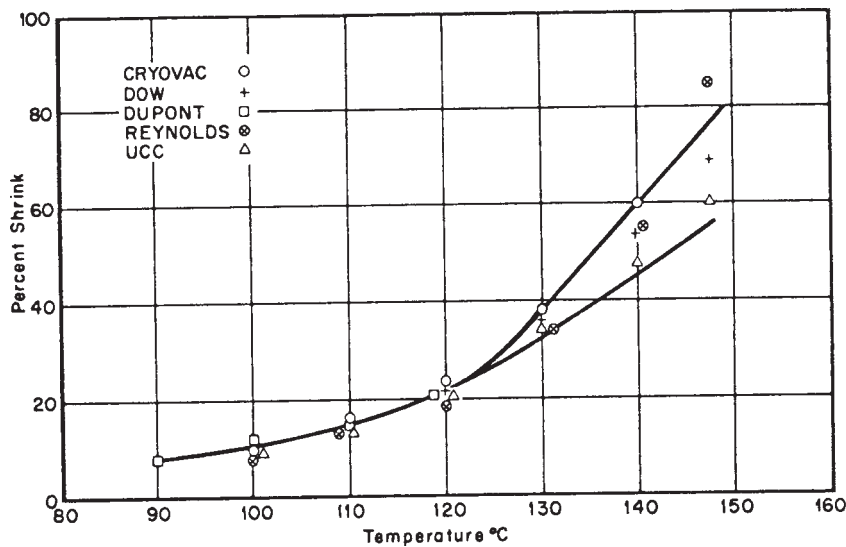

FIG. 4 Round-Robin Data for Machine-Direction Shrinkage of Biaxially-Oriented Polysulfone Sheetting

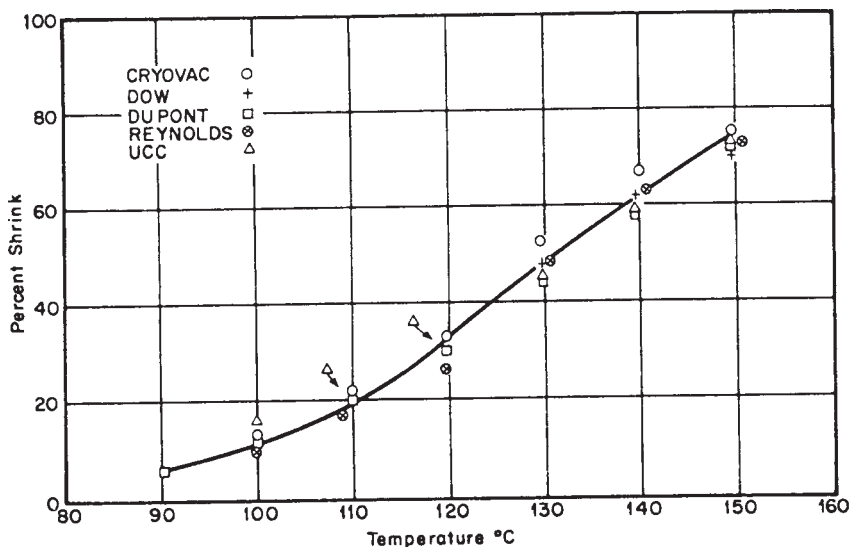

FIG. 5 Round Robin Data for Transverse-Direction Shrinkage of Biaxially-Oriented Polysulfone Sheetting

SUMMARY OF CHANGES

This section identifies the location of selected changes to this test method. For the convenience of the user, Committee D20 has highlighted those changes that may impact the use of this test method. This section may also include descriptions of the changes or reasons for the changes, or both.

D 2732 - 03:

- (1) Revised Note 1.
- (2) Added Terminology D 883.
- (3) Deleted Practice D 1898.
- (4) Added ISO 11501 to Referenced Documents section.
- (5) Deleted paragraph 6.3.

ASTM International takes no position respecting the validity of any patent rights asserted in connection with any item mentioned in this standard. Users of this standard are expressly advised that determination of the validity of any such patent rights, and the risk of infringement of such rights, are entirely their own responsibility.

This standard is subject to revision at any time by the responsible technical committee and must be reviewed every five years and if not revised, either reapproved or withdrawn. Your comments are invited either for revision of this standard or for additional standards and should be addressed to ASTM International Headquarters. Your comments will receive careful consideration at a meeting of the responsible technical committee, which you may attend. If you feel that your comments have not received a fair hearing you should make your views known to the ASTM Committee on Standards, at the address shown below.

This standard is copyrighted by ASTM International, 100 Barr Harbor Drive, PO Box C700, West Conshohocken, PA 19428-2959, United States. Individual reprints (single or multiple copies) of this standard may be obtained by contacting ASTM at the above address or at 610-832-9585 (phone), 610-832-9555 (fax), or service@astm.org (e-mail); or through the ASTM website (www.astm.org).