



Designation: **D 2765 – 9501**

## Standard Test Methods for Determination of Gel Content and Swell Ratio of Crosslinked Ethylene Plastics<sup>1</sup>

This standard is issued under the fixed designation D 2765; the number immediately following the designation indicates the year of original adoption or, in the case of revision, the year of last revision. A number in parentheses indicates the year of last reapproval. A superscript epsilon ( $\epsilon$ ) indicates an editorial change since the last revision or reapproval.

### 1. Scope\*

1.1 The gel content (insoluble fraction) produced in ethylene plastics by crosslinking can be determined by extracting with solvents such as decahydronaphthalene or xylenes. Such extraction test methods are described herein. They are applicable to crosslinked ethylene plastics of all densities, including those containing fillers, and all provide corrections for the inert fillers present in some of those compounds.

1.2 Test Method A, which permits most complete extraction in least time, is to be used for referee tests, but two alternative nonreferee Test Methods B and C are also described. The first of these differs from the referee test method only in sample preparation; that is, it requires use of shavings taken at selected points in cable insulation, for example, rather than the ground sample required by the referee test method. Because the shaved particles are larger, less total surface per sample is exposed to the extractant, so this test method ordinarily yields extraction values about 1 to 2 % lower than the referee method. The second of the alternative test methods requires that a specimen in one piece be extracted in xylene<sub>s</sub> at a constant temperature of 110°C. At this temperature and with a one-piece specimen, even less extraction occurs (from 3 to 9 % less than the referee test method) but swell ratio (a measure of the degree of crosslinking in the gel phase) can be determined.

1.3 Extraction tests can be made on articles of any shape. They have been particularly useful for electrical insulations since specimens may be selected from those portions of the insulation most susceptible to insufficient crosslinking.

1.4 The values stated in SI units are to be regarded as the standard. The inch-pound units in parentheses are for information only.

~~NOTE 1—There is no equivalent ISO Method similar to this test, but is not equivalent.~~

1.5 *This standard does not purport to address all of the safety concerns, if any, associated with its use. It is the responsibility of the user of this standard to establish appropriate safety and health practices and determine the applicability of regulatory limitations prior to use.* Specific precautionary statements are given in Sections 6, 10, and 25.

### 2. Referenced Documents

#### 2.1 ASTM Standards:

D 297 Test Methods for Rubber Products—Chemical Analysis<sup>2</sup>

<sup>1</sup> These test methods are under the jurisdiction of ASTM Committee D-20 on Plastics and are the direct responsibility of Subcommittee D20.125 on ~~Olefin Plastics; Thermoplastic Materials.~~

Current edition approved ~~Nov. 10, 1995; 2001.~~ Published ~~January 1996; August 2001.~~ Originally published as D 2765 – 68. Last previous edition D 2765 – 905.

\*A Summary of Changes section appears at the end of this standard.

- D 618 Practice for Conditioning Plastics and Electrical Insulating Materials for Testing<sup>3</sup>
- D 883 Terminology Relating to Plastics<sup>3</sup>
- D 1603 Test Method for Carbon Black in Olefin Plastics<sup>3</sup>
- D 1998 Specification for Polyethylene Upright Storage Tank<sup>3</sup>
- D 3351 Test Method for Gel Count of Plastic Film<sup>4</sup>
- E 691 Practice for Conducting an Interlaboratory Study to Determine the Precision of a Test Method<sup>5</sup>

### 3. Terminology

3.1 *Definitions of Terms Specific to This Standard:*

3.1.1 *gel content*—the percentage by mass of polymer insoluble in a specified solvent after extraction under the specified conditions.

3.1.2 *soluble*—capable of being loosened or dissolved, susceptible of being dissolved in or as if in a fluid. (See Webster's Ninth New Collegiate Dictionary, 1988.)

3.1.3 *swell ratio*—the ratio of the gel volume in the swollen state to its volume in the unswollen state.

3.2 Terms as shown in Terminology D 883 are applicable to this test method.

### 4. Summary of Test Methods

4.1 Specimens of the crosslinked ethylene plastic are weighed and then immersed in the extracting solvent at the temperature specified by the procedure selected and for the time designated by that procedure. After extraction, the specimens are removed, dried, and reweighed as directed. The amount of material extracted is calculated and, if desired, swell ratio also may be determined by the means described in alternative Test Method C.

### 5. Significance and Use

5.1 Many important properties of crosslinked ethylene plastics vary with the gel content. Hence, determination of the gel content provides a means of both controlling the process and rating the quality of finished products.

5.2 Extraction tests permit verification of the proper gel content of any given crosslinked ethylene plastic and they also permit comparison between different crosslinked ethylene plastics, including those containing fillers, provided that, for the latter, the following conditions are met:

5.2.1 The filler is not soluble in either decahydronaphthalene or xylenes at the extraction temperature.

5.2.2 The amount of filler present in the compound either is known or can be determined.

5.2.3 Sufficient crosslinking has been achieved to prevent migration of filler during the extraction. Usually it has been found that, at extraction levels up to 50 %, the extractant remains clear and free of filler.

5.3 Since some oxidative degradation of the material can occur at the reflux temperature of the extractants, a suitable antioxidant is added to the extractant to inhibit such degradation.

5.4 Before proceeding with this test method, reference should be made to the specification of the material being tested. Any test specimen preparation, conditioning, dimensions, or testing parameters, or a combination thereof, covered in the materials specification shall take precedence over those mentioned in this test method. If there are no material specifications, then the default conditions apply.

### 6. Precautions

6.1 This test method measures a much larger three-dimensional polymer network than that measured by Test Method D 3351 and should not be confused with it.

6.2 It has been reported that crosslinked ultra-high molecular weight polyethylene fails to completely dissolve in this procedure at times.

### 7. Conditioning

7.1 *Conditioning*—Condition the test specimens at  $23 \pm 2^\circ\text{C}$  ( $73.4 \pm 3.6^\circ\text{F}$ ) and  $50 \pm 5\%$  relative humidity for not less than 40 h prior to test in accordance with Procedure A of Practice D 618, for those tests where conditioning is required. In cases of disagreement, the tolerances shall be  $\pm 1^\circ\text{C}$  ( $\pm 1.8^\circ\text{F}$ ) and  $\pm 2\%$  relative humidity ( $\pm 1.8^\circ\text{F}$ ).

7.2 *Test Conditions*—Conduct tests—Prepare samples in the standard laboratory atmosphere of  $23 \pm 2^\circ\text{C}$  ( $73.4 \pm 3.6^\circ\text{F}$ ) and  $50 \pm 5\%$  relative humidity ( $3.6^\circ\text{F}$ ), unless otherwise specified in the test methods. In cases of disagreement, the tolerances shall be  $\pm 1^\circ\text{C}$  ( $\pm 1.8^\circ\text{F}$ ) and  $\pm 2\%$  relative humidity ( $\pm 1.8^\circ\text{F}$ ).

## TEST METHOD A (REFEREE TEST METHOD)

### 8. Apparatus

8.1 The extraction apparatus shall be of the following general type, as illustrated in Fig. 1:

<sup>2</sup> Annual Book of ASTM Standards, Vol 09.01.

<sup>3</sup> Annual Book of ASTM Standards, Vol 08.01.

<sup>4</sup> Annual Book of ASTM Standards, Vol 08.02.

<sup>5</sup> Annual Book of ASTM Standards, Vol 14.02.

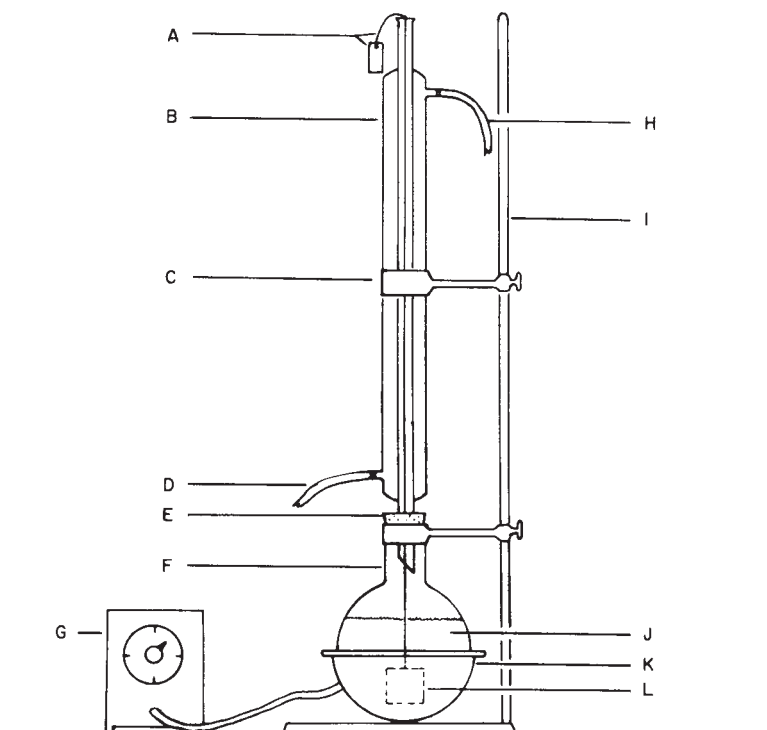

A—Identification tag and fine wire attached to cage.  
 B—Reflux condenser.  
 C—Ring stand clamp.  
 D—Water inlet.  
 E—Ground-glass or cork joint.  
 F—Large-mouth round-bottom flask.  
 G—Variable transformer.  
 H—Water outlet.  
 I—Ring stand.  
 J—Decahydronaphthalene or xylene.  
 K—Heating mantle.  
 L—120-mesh wire cage containing the specimen.

**FIG. 1 Extraction Apparatus**

8.1.1 *Round-Bottom Flask*, with large-mouth ground-glass or cork joint. For one or two determinations at one time, a 500-mL flask is appropriate. For several determinations at one time, but not exceeding six, a 2000-mL flask is suitable.

8.1.2 *Heating Mantle* to fit the flask and with sufficient heating capacity to boil decahydronaphthalene (boiling point 190 to 193°C) or xylenes (boiling point 138 to 141°C).

8.1.3 *Reflux Condenser* with ground-glass or cork joint to fit into flask.

8.1.4 *Ring Stand and Appropriate Clamps*.

8.1.5—

8.2 *Grinding Equipment*, suitable for reducing the sample to a fineness between 30 and 60 mesh. A bench-top laboratory mill<sup>6</sup> is satisfactory, although any procedure which will produce a sample of the required fineness without generating excessive heat may be used.

8.1.6—

8.2.1 *U.S. No. 30 and U.S. No. 60 Sieves*.

8.1.7—

8.2.2 *U.S. No. 120 Stainless Steel Wire Cloth*.

8.1.8—

8.3 *Vacuum Oven*, with vacuum source capable of creating a vacuum of at least 710 mm (28 in.) Hg and equipped with a thermometer capable of measuring 150°C.

8.4 *Analytical Balance*, capable of weighing to 0.001 g.

NOTE 2—If a slightly higher degree of accuracy is desired (about 1 to 2 %) a modified Soxhlet Extractor; Kontes Catalog No. 586100-0023, Size C, Kontes Glass Co., Vineland, NJ or equivalent may be employed wherein the specimen is held in an extraction thimble. The extraction thimble, with

<sup>6</sup> A Wiley Cutting Mill, Intermediate Model, or equivalent, Catalog No. 08-338, available from Fisher Scientific Co., 711 Forbes Ave., Pittsburgh, PA 15219, has been found satisfactory for this purpose.

extra-coarse fritted glass disk sealed in; ~~Corning Glass Catalog No. 33950, Kontes 586500-0023~~, 45-mm body diameter, 130-mm height or equivalent (height must subsequently be cut to 75 mm). The fritted disk is extra-coarse with fused edge; ~~Corning Glass Catalog No. 31000, Kontes 952000-4025~~, 40-mm diameter or equivalent. Glass wool 13 to 19 mm thick ( $\frac{1}{2}$  to  $\frac{3}{4}$  in.) placed on the bottom of the extraction thimble to support one gram 30–60 mesh ground sample which is covered with 13 to 19 mm thick layer of glass wool, a fritted glass disk and a small glass weight. The extraction thimble assembly rests upon the 55-mm portion of the thimble previously cut off, the latter inserted into the modified Soxhlet.

## 9. Reagents

- 9.1 *Decahydronaphthalene*, ~~practical, anhydrous~~, boiling point ~~190~~ 189 to 193°C.
- 9.2 *Xylenes*, ACS reagent grade, boiling point 138 to 141°C.
- 9.3 *2,2'-methylene-bis (4-methyl-6-tertiary butyl phenol)*.<sup>7</sup>

## 10. Safety Precautions

10.1 *Xylenes* and decahydronaphthalene are toxic and flammable solvents and as such should be handled carefully. Use only in a ventilated hood. Check the effectiveness of the hood before starting the tests. Do not inhale the vapors. Excessive inhalation of the vapors may cause dizziness or headache, or both. In the event of excessive inhalation, seek fresh clean air.

## 11. Test Specimens

- 11.1 At least two specimens each containing  $0.300 \pm 0.015$  g of ground polymer weighed to the nearest 0.001 g shall be tested.
- 11.2 The test samples shall be ground to a fineness that will pass through a 30-mesh sieve. Shake this sieved material over a 60-mesh sieve and reject any material that passes through.
- 11.3 Test specimens originating from insulation cut from wire should be homogeneous and consist of an equal mixture of samples representative of insulation nearest to the conductor and samples representative of insulation nearest the outer periphery of the construction unless specific portions of the insulation are being examined for insufficient crosslinking.

## 12. Procedure

12.1 Prepare a specimen holder by cutting a piece of 120-mesh stainless steel cloth measuring approximately 80 by 40 mm (3 by  $1\frac{1}{2}$  in.). Fold this to form a square measuring approximately 40 mm ( $1\frac{1}{2}$  in.). Fold two sides of this square closed by folding the cloth at the edges about 6 to 7 mm ( $\frac{1}{4}$  in.) and stapling those folds. In that manner, a pouch open at the top is obtained. Weigh this pouch (*W1*).

12.2 Place approximately 0.3 g of the ground and screened sample in the weighed pouch. Weigh the pouch and specimen (*W2*). Fold over the open side of the pouch and staple the edge to form a cage. Weigh the cage and sample (*W3*).

12.3 Fill a round-bottom flask as described in 8.1.1 with enough solvent to immerse the 120-mesh cage and sample completely. Three hundred fifty grams in a 500-mL flask or 1000 g in a 2000-mL flask is sufficient. Dissolve 1 % of antioxidant in the decahydronaphthalene or xylenes to inhibit further crosslinking of the specimen.

12.4 Boil the decahydronaphthalene or xylenes vigorously enough to ensure good agitation of the solution. Twenty to 40 drops/min from the condenser, while using 1000 g of solvent, is a satisfactory boiling rate. Suspend the cage and specimen in the solvent so that the bottom edge of the cage is almost touching the bottom of the flask. A small wire, attached to the cage and extending through the reflux condenser can be used for suspending the cage. Extract the specimen for 6 h in decahydronaphthalene or for 12 h in xylenes.

NOTE 3—Since most of the extraction occurs within less than the specified time, the period of extraction may be shortened for control tests on the basis of experience. If this is done, the time of extraction must be reported. For referee tests, extraction time is to be as specified by this test method.

12.5 After extraction, place the cage and specimen immediately in a vacuum oven preheated to 150°C. Dry the specimen to constant weight under at least 710 mm (28 in.) Hg vacuum. Cool and weigh (*W4*). If the compound absorbs moisture, cool the specimen in a desiccator before weighing.

NOTE 4—It has been reported that drying time sometimes can be materially shortened if the cage and sample are cooled for 15 min and then are placed either on a suspended screen or on lint-free absorbent material to remove excess solvent before being put into the vacuum drying oven.

12.6 If extraction tests are regularly made, the apparatus may be left assembled and the extracting solvent (containing inhibitor as directed) may be reused until it darkens. However, if there is any doubt about the values obtained with reused extractant, the test should be repeated with fresh extractant.

NOTE 5—If the modified Soxhlet apparatus is used, the complete thimble assembly containing 1 g of sample is weighed to the nearest  $\pm 0.0001$  g before extraction and after vacuum drying.

## 13. Calculation

- 13.1 Calculate the solvent extraction in percent as follows:

<sup>7</sup> Antioxidant, available from Cytec under the trade name Cyanox 2246, has been found satisfactory for this purpose. Cytec Industries, Polymer Additive Department, 5 Garret Mountain Plaza, West Paterson, NJ 07424.

$$\text{Extract, \%} = \frac{\text{(weight lost during extraction)}}{\text{(weight of original specimen - weight of filler)}} \tag{1}$$

$$\begin{aligned} &= \frac{[(W_3 - W_4) - F(W_2 - W_1)]}{(W_2 - W_1) - F(W_2 - W_1)} \times 100 \\ &= \frac{[(W_3 - W_4) - F(W_2 - W_1)]}{(1 - F)(W_2 - W_1)} \times 100 \\ &= \frac{[(W_3 - W_4) - F(W_2 - W_1)]}{(1 - F)(W_2 - W_1)} \times 100 \\ &= \frac{[(W_3 - W_4) - F(W_2 - W_1)]}{(1 - F)(W_2 - W_1)} \times 100 \end{aligned}$$

where:

- $W_1$  = weight of the pouch (sealed on three sides, one side open),
- $W_2$  = weight of the specimen and the pouch (sealed on three sides, one side open),
- $W_3$  = weight of the specimen and the cage, after being stapled shut,
- $W_4$  = weight of the specimen and the cage after extraction and drying,
- $F$  = fraction of filler (which must be insoluble in decahydronaphthalene or xylenes) in the polyethylene compound, and gel content = 100 - percent extract.

NOTE 6—If the fraction of filler in the material is not known, the test methods described in Test Method D 1603 or in Test Methods D 297, may be used to determine filler content.

**14. Report**

14.1 Report the following information:

- 14.1.1 Complete identification of the compound,
- 14.1.2 Density of the polyethylene in the compound (usually as identified by its supplier),
- 14.1.3 Weight percent of polyethylene in the compound (usually as identified by its supplier, although it may be determined by the test methods identified in Note 6),
- 14.1.4 Percent extract; the value for each specimen and the average for the sample,
- 14.1.5 Solvent used, time of extraction, and any pertinent sample preparation, and
- 14.1.6 Any unusual or abnormal behavior observed during the test.

**TEST METHOD B (NONREFEREE TEST METHOD)**

**15. Scope**

15.1 This modification of the referee test method was developed particularly for wire and cable insulations and differs from the referee test method only in specimen preparation.

15.2 In using this alternative test method, it should be recognized that the values obtained may be lower than those obtained by referee Test Method A for the reason given in 1.2.

**16. Test Specimens**

16.1 Using a wood plane, shave a strip approximately 0.4 mm (0.015 in.) thick parallel to the axis of the insulated conductor. The test strip used for extraction should be taken next to the conductor only when strand shielding tapes or compounds are not employed. In high-voltage cable employing strand shielding tapes or compounds, the strip should be shaved as closely as possible along the shielded surface, being careful not to include any of the semiconducting compound (see Fig. 2).

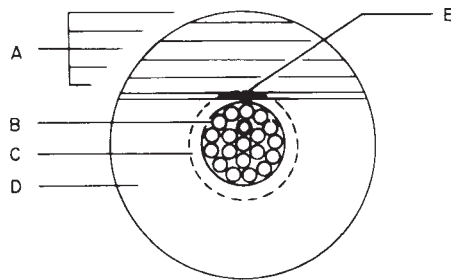

- A—Shaved strips to be discarded.
- B—Semiconducting strand shield.
- C—Area most susceptible to insufficient crosslinking.
- D—Crosslinked polyethylene insulation.
- E—Specimen for solvent extraction (shaded area).

**FIG. 2 Enlarged Cross-Sectional View of High-Voltage Cable Showing Sample Location**

16.2 A section approximately 6 mm (¼ in.) wide, depending on cable size, is cut longitudinally through the center portion of the strip obtained as described in 15.1. The outer sections of this strip are discarded, thus leaving only a sample of the material closest to the conductor or shielded surface. This sample then is cut or diced into pieces measuring approximately 6 by 6 mm (¼ by ¼ in.) for extraction.

16.3 The dimensions given in 15.2 are for cable sizes 1/0 AWG and larger. For Size 2 AWG and smaller, the dimensions should be proportionately less.

### 17. Procedure

17.1 Place approximately 0.3 g of the diced sample, prepared as described in Section 15, 16, in a previously weighed pouch ( $W_1$ ) and then reweigh ( $W_2$ ). Close the pouch by folding over the open side and stapling it to form a cage. Weigh this cage and the sample again ( $W_3$ ) (see Section 12 of Test Method A).

17.2 Conduct the extraction as described in Section 12, using decahydronaphthalene as the extractant.

17.3 After extraction, dry the specimen and reweigh also as described in Section 12.

### 18. Calculation

18.1 Calculate solvent extraction in percent as described in Section 13 of the referee test method.

### 19. Report

19.1 See Section 14 but include identification of the alternative test method used (Test Method B).

## TEST METHOD C (NONREFEREE TEST METHOD)

### 20. Scope

20.1 Degree of crosslinking is determined by measuring the swell and extraction occurring in a solvent that attacks that portion of the polymer which is not crosslinked. Both measurements are obtained in one test. The degree of crosslinking is not expressed as a percent of total crosslinkability or similar expression, but is judged from swell ratio and percent extract based on experience with the particular polymer-solvent system under consideration.

20.2 This test method is applicable to crosslinked ethylene plastics of any density and including those containing fillers, provided that the fillers are insoluble in the extractant.

20.3 In using this alternative test method, it should be recognized that the extraction values obtained will be lower than those obtained by either Test Method A or Test Method B for the reasons given in 1.2. However, this test method permits swell ratio to be determined.

### 21. Summary of Test Method

21.1 Specimens of the crosslinked polymer are weighed, immersed in hot xylene for 24 h, removed, weighed in the swollen state, and dried and reweighed. The swell ratio and percent extract are calculated from these weight measurements.

### 22. Significance and Use

22.1 This test method provides useful measurements when the temperature of the solvent in which the polymer is immersed is above the crystalline melting point of the polymer and below the temperature at which chemical degradation begins to occur. Xylene, which thermodynamically is a good solvent for polyethylene, depresses the melting point of polyethylene (in accordance with Flory's theory of diluent forces) about 30°C. In the presence of xylene, polyethylene in the density range from 0.910 to 0.925 g/cm<sup>3</sup> (low density) has a melting point less than 80°C, and polyethylene in the density range from 0.941 to 0.965 g/cm<sup>3</sup> (high density) has a melting point less than 110°C. Thus, tests on both types of polyethylene can be made at 110°C.

22.2 The percent extract is a measure of the amount of polymer that is soluble or is not entrapped in the main gel phase, or both, at the end of the immersion period. Provided that no chemical degradation occurs, the greater the degree of crosslinking the lower the amount of extract (lower percent extract).

22.3 Swell ratio is a relative measure of crosslinking in the main gel phase. Provided that no chemical degradation occurs, the lower the swell ratio the greater the crosslinking and the lower the molecular weight between crosslinks.

### 23. Apparatus

23.1 *Oil Bath* at 110°C, agitated to ensure temperature uniformity.

23.2 *Wide-Mouth Glass Jars*, 8-oz, with screw caps.

23.3 *Analytical Balance*, accurate to 0.001 g.

23.4 *Forceps*, long, 250-mm (10-in.)

23.5 *Cutting Devices* to cut specimens from sample.

23.6 *Vacuum Oven* at 100°C, with pump and cold trap.

23.7 *Flasks*, 100-mL, 24/40 joint.

23.8 *Desiccator*, containing drying agent.



23.9 *Weighing Bottles*, 30-mL and 60-mL.

23.10 *Automatic Pipet*, 100-mL, 24/40 joint. Pipet, 100 mL, or Bottle Top Dispenser capable of dispensing 100 mL of liquid.

## 24. Reagents and Materials

24.1 *Xylenes*, ACS reagent grade, boiling point 138 to 141°C.

24.2 *Oil*, stable at 110°C.

24.3 *Acetone*, ~~ACS reagent~~ technical grade.

24.4 *Dry Ice*.

## 25. Safety Precautions

25.1 Xylene is are toxic and flammable ~~solvent~~ and as such should be handled carefully. Use only in a ventilated hood. Check the effectiveness of the hood before starting the tests. Do not inhale the vapors. Excessive inhalation of the vapors may cause dizziness or headache, or both. In case of excessive inhalation, seek fresh clean air.

## 26. Test Specimens

26.1 At least two specimens each containing  $0.500 \pm 0.020$  g of polymer shall be weighed to the nearest 0.001 g.

26.2 The test specimens shall be cut with sharp tools from the sample and all edges shall be smooth and clean. The surface-to-volume ratio shall be kept as small as reasonably possible.

26.3 Test specimens consisting of insulation cut from wire shall be slit longitudinally. If necessary, they may be cut into two or three pieces crosswise so that they can be completely submerged in the solvent.

## 27. Procedure

27.1 Place the weighed test specimen in an 8-oz jar; add  $100 \pm 0.1$  mL of xylenes with the automatic pipet; make sure the test specimen is completely immersed in the xylene solvent (Note 7); screw the cap on the jar finger tight.

NOTE 7—The xylene solvent must cover the *swollen* test specimen at the conclusion of the immersion period to obtain reliable results. Tests ~~should~~ shall be discarded and repeated with a fresh test specimen if specimens are not covered with xylene solvent at the conclusion of the extraction step.

27.2 Place the jar in the oil bath so that the level of the oil is at or slightly above the level of the xylene solvent in the jar. The temperature of the oil bath must be 110°C and the bath must be at that temperature within  $\pm 0.5^\circ\text{C}$  no less than  $\frac{1}{2}$  h after the jar is placed therein. If necessary, place a weight on the jar or clamp it to hold it in place.

27.3 Maintain the oil bath at the proper temperature within  $\pm 0.5^\circ\text{C}$  for 24 h, with agitation.

NOTE 8—The immersion period specified seems to be adequate to reach an approximate equilibrium state for swell measurements. Increasing this period to 72 h had no significant effects on the results. However, a longer immersion period does slightly increase the values for percent extract.

27.4 Remove the jar after 24 h in the hot oil bath and transfer the swollen test specimen with the forceps without delay to a clean, dry tared weighing bottle (Note 9). Handle the swollen test specimen gently and carefully. Blow the surfaces (Note 10). Stopper the weighing bottle.

NOTE 9—The size of the swollen test specimen dictates the size of the weighing bottle to be used.

NOTE 10—Extreme care must be used in handling the swollen test specimen to obtain reliable results. The test specimen should not be squeezed with the forceps. The transfer of the test specimen should be made quickly. The surfaces should not be subjected to excess blowing (too long or more than once on each side); otherwise more than the surface xylene will be removed.

Test specimens that break up during the immersion period (usually very low degrees of crosslinking) can be caught on a 60-mesh or finer stainless steel screen, transferred to a weighing bottle, and treated in the specified manner. Results obtained from such specimens are of limited value. If the system is unfilled, the swell ratio will be in error because it is impossible to eliminate the surface xylene, but the percent extract will be correct if all the gel particles were collected. If the system is filled, both the swell ratio and the percent extract will be erroneous because of loss of filler.

27.5 Place the weighing bottle in the desiccator, allow to cool to room temperature, and weigh to the nearest 0.001 g.

27.6 Place the opened weighing bottle with the swollen test specimen in the vacuum oven at 100°C. Apply vacuum slowly. Cool cold trap with dry ice and acetone to catch and condense xylene vapor. Heat in vacuum until xylene is all removed, as determined by repeated weighing. Formulations containing low-density polyethylene usually require 24 h and those containing high-density polyethylene require 16 h to reach weight equilibrium.

## 28. Calculation (See Note 11 for Derivation)

28.1 Calculate the swell ratio as follows:

$$\text{Swell ratio} = K + 1 \quad (2)$$

$$\text{Swell ratio} = K + 1 \quad (2)$$

28.2 Calculate the percent extract as follows:

$$\text{Extract, \%} = [(W_s - W_d)/W_o] \times 100 \quad (3)$$

$$\text{Extract, \%} = [(W_s - W_d)/W_o] \times 100 \quad (3)$$

where:

- $f$  = polymer factor (the ratio of the weight of the polymer in the formulation to the total weight of the formulation)
- $W_o$  = original polymer weight (the amount of polymer in the specimen being tested)
- $W_s$  = weight of specimen being tested
- $W'_o$  =  $fW_s$
- $W_e$  = weight of extract (amount of polymer extracted from the specimen in the test)
- $W_g$  = weight of swollen gel after the immersion period
- $W_d$  = weight of dried gel
- $W_e$  =  $W_s - W_d$ , weight of xylene in swollen gel
- $W_p$  = weight of insoluble polymer in swollen gel
- $W'_p$  =  $W_o - W_e$
- $D_p$  = density of polymer at the immersion temperature
- $V_p$  = volume of polymer in gel
- $V'_p$  =  $(W_o - W_e)/D_p = W_p/D_p$
- $W_x$  = weight of solvent in gel
- $W'_x$  =  $W_g - W_d$
- $D_x$  = density of solvent at the immersion temperature
- $V_x$  = volume of solvent in gel
- $V'_x$  =  $(W_g - W_d)/D_x = W_x/D_x$
- $K$  = ratio of density of polymer to that of the solvent at the immersion temperature. This ratio is approximately 1.07 for low-density polyethylene at 80°C and 1.17 for high-density polyethylene at 110°C

28.3 High swell ratios indicate a low degree of crosslinking, that is, a high molecular weight between crosslinks. Low swell ratios indicate a more tightly bound structure. Low values of percent extract indicate a high degree of crosslinking.

NOTE 11—Derivation of calculations:

Swell ratio	=	(volume of polymer in gel + volume of absorbed xylene)/(volume of polymer in gel)
	=	$(V_p + V_x)/V_p = ((W_p/D_p) + (W_x/D_x))/(W_p/D_p)$
	=	$= 1 + (D_p/D_x)(W_x/W_p)$
	=	$1 + (D_p/D_x)(W_x/W_p) = 1 + K(W_x/W_p)$
	=	$1 + K((W_g - W_d)/(W_o - W_e))$
	=	$= 1 + K[(W_g - W_d)/(W_d - (1 - f)W_s)]$
Extract, %	=	(weight of extract/original polymer weight) × 100
	=	$(W_e/W_o) \times 100 = [(W_s - W_d)/W_d] \times 100$
	=	$[(W_s - W_d)/fW_s] \times 100$

## 29. Report

29.1 Report the following information:

- 29.1.1 Complete identification of the compound,
- 29.1.2 Density of the polyethylene polymer in the compound (usually as identified by its supplier),
- 29.1.3 Weight percent of polyethylene in the compound (usually as identified by its supplier, although it may be determined by the methods identified in Note 6),
- 29.1.4 Swell ratio; the value for each specimen and the average for the sample,
- 29.1.5 Percent extract; the value for each specimen and the average for the sample,
- 29.1.6 Identification of the method used, that is, Method C,
- 29.1.7 Any deviations from this test method and the reasons for such deviations, and
- 29.1.8 Any unusual or abnormal behavior observed during the test.

## 30. Precision and Bias <sup>8</sup>

30.1 *Test Method A*—Table 1 is based on a round robin conducted in 1967 involving six materials tested by three laboratories. For each material, all the samples were prepared at one source, but the individual specimens were prepared at the laboratories that tested them. Each test result was the result of one individual determination. Each laboratory obtained ~~two~~ three test results for each material.

30.2 *Test Method B*—Table 1 is based on a round robin conducted in 1967 involving six materials tested by one laboratory. For each material, all the samples were prepared at one source, but the individual specimens were prepared at the laboratory that tested them. Each test result was the result of one individual determination. Each laboratory obtained ~~two~~ three test results for each material.

30.3 *Test Method C*—Table 1 is based on a round robin conducted in 1967 involving six materials tested by three laboratories. For each material, all the samples were prepared at one source, but the individual specimens were prepared at the laboratory that tested them. Each test result was the result of one individual determination. Each laboratory obtained ~~two~~ three test results for each material.

<sup>8</sup> Supporting data are available from ASTM Headquarters. Request RR:D20-45.



**TABLE 1 Percent Extract and Swell Ratio**

NOTE 1— $S_r$  = within-laboratory standard deviation of the average.  
 $SR$  = between-laboratories standard deviation of the average.  
 $I_r = 2.80 S_r$ ;  
 $IR = 2.80 SR$ .

Test Method A (Percent Extract)					
Material	Average	$S_r$	$SR$	$I_r$	$IR$
1	19.57	0.635	1.57	1.78	4.40
2	20.57	0.743	1.38	2.08	3.86
3	18.59	0.529	1.60	1.48	4.48
4	18.97	1.89	1.56	5.29	4.37
5	10.71	0.687	2.37	1.92	6.64
6	14.09	1.35	1.34	3.78	3.75

Test Method B (Percent Extract)					
Material	Average	$S_r$	$SR$	$I_r$	$IR$
1	18.00	0.200	0.00	0.560	0.00
2	17.97	0.057	0.00	0.160	0.00
3	17.30	0.100	0.00	0.280	0.00
4	15.73	0.305	0.00	0.854	0.00
5	10.53	0.379	0.00	1.06	0.00
6	12.97	0.251	0.00	0.703	0.00

Test Method C (Percent Extract)					
Material	Average	$S_r$	$SR$	$I_r$	$IR$
1	14.63	1.04	0.741	2.91	02.07
2	16.51	1.26	0.205	3.53	0.570
3	14.17	0.160	0.180	0.448	0.500
4	11.74	0.402	1.01	1.12	2.83
5	7.044	0.734	1.39	2.06	3.89
6	10.05	0.786	1.86	2.20	5.21

Test Method C (Swell Ratio)					
Material	Average	$S_r$	$SR$	$I_r$	$IR$
1	6.500	0.187	2.54	0.524	7.11
2	7.583	0.216	2.71	0.605	7.59
3	5.917	0.191	2.43	0.535	6.80
4	6.367	0.258	2.64	0.722	7.39
5	4.417	0.153	1.20	0.428	3.36
6	3.833	0.082	0.894	0.230	2.50

NOTE 12—**Caution:** The following explanations of  $r$  and  $R$  (30.4-30.4.3) are only intended to present a meaningful way of considering the approximate precision of this test method. The test data in Table 1 should not be rigorously applied to acceptance or rejection of these materials, as those data are specific to the round robin and may not be representative of other lots, conditions, materials, or laboratories. Users of this test method should apply the principles outlined in Practice E 691 to generate data specific to their laboratory and materials, or between specific laboratories. The principles of 30.4-30.4.3 would then be valid for such data.

30.4 *Concept of  $r$  and  $R$* —If  $S_r$  and  $S_R$  have been calculated from a large enough body of data, and for test results that were averages (medians/other functions) from testing two specimens:

30.4.1 *Repeatability,  $r$* —(Comparing two test results for the same material, obtained by the same operator using the same equipment on the same day) the two test results should be judged not equivalent if they differ by more than the  $r$  value for that material.

30.4.2 *Reproducibility,  $R$* —(Comparing two test results for the same material, obtained by different operators using different equipment on different days) the two test results should be judged not equivalent if they differ by more than the  $R$  value for that material.

30.4.3 Any judgment in accordance with 30.4.1 or 30.4.2 would have an approximate 95 % (0.95) probability of being correct.

30.5 There are no recognized standards by which to estimate bias of this test method.

### 31. Keywords

31.1 crosslinked ethylene plastics; gel content; insoluble fraction; swell ratio.

**SUMMARY OF CHANGES**

Committee D20 has identified the location of selected changes to this test method since the last issue that may impact the use of this procedure.

D 2765 – 95:

- (1) ISO statement was changed.
- (2) Changed xylene to xylenes where appropriate.
- (3) Updated equipment catalog numbers in Note 2.
- (4) Removed humidity requirement as per D 4976.
- (5) Corrected an error in the Precision and Bias statement as per Research Report.
- (6) General editorial changes were made throughout the standard.

*ASTM International takes no position respecting the validity of any patent rights asserted in connection with any item mentioned in this standard. Users of this standard are expressly advised that determination of the validity of any such patent rights, and the risk of infringement of such rights, are entirely their own responsibility.*

*This standard is subject to revision at any time by the responsible technical committee and must be reviewed every five years and if not revised, either reapproved or withdrawn. Your comments are invited either for revision of this standard or for additional standards and should be addressed to ASTM International Headquarters. Your comments will receive careful consideration at a meeting of the responsible technical committee, which you may attend. If you feel that your comments have not received a fair hearing you should make your views known to the ASTM Committee on Standards, at the address shown below.*

*This standard is copyrighted by ASTM International, 100 Barr Harbor Drive, PO Box C700, West Conshohocken, PA 19428-2959, United States. Individual reprints (single or multiple copies) of this standard may be obtained by contacting ASTM at the above address or at 610-832-9585 (phone), 610-832-9555 (fax), or [service@astm.org](mailto:service@astm.org) (e-mail); or through the ASTM website ([www.astm.org](http://www.astm.org)).*