



Standard Test Method for Coefficient of Linear Thermal Expansion of Plastics Between –30°C and 30°C with a Vitreous Silica Dilatometer ¹

This standard is issued under the fixed designation D 696; the number immediately following the designation indicates the year of original adoption or, in the case of revision, the year of last revision. A number in parentheses indicates the year of last reapproval. A superscript epsilon (ε) indicates an editorial change since the last revision or reapproval.

1. Scope*

1.1 This test method covers determination of the coefficient of linear thermal expansion for plastic materials having coefficients of expansion greater than 1×10^{-6} 1°C by use of a vitreous silica dilatometer. At the test temperatures and under the stresses imposed, the plastic materials shall have a negligible creep or elastic strain rate or both, insofar as these properties would significantly affect the accuracy of the measurements.

NOTE 1—There is no similar or equivalent ISO standard.

1.1.1 Test Method E 228 shall be used for temperatures other than –30°C to 30°C.

1.1.2 This test method shall not be used for measurements on materials having a very low coefficient of expansion (less than 1×10^{-6} 1°C). For materials having very low coefficient of expansion, interferometer or capacitance techniques are recommended.

1.2 The thermal expansion of a plastic is composed of a reversible component on which are superimposed changes in length due to changes in moisture content, curing, loss of plasticizer or solvents, release of stresses, phase changes and other factors. This test method is intended for determining the coefficient of linear thermal expansion under the exclusion of these factors as far as possible. In general, it will not be possible to exclude the effect of these factors completely. For this reason, the test method can be expected to give only an approximation to the true thermal expansion.

1.3 The values stated in SI units are to be regarded as the standard. The values in parentheses are for information only.

1.4 *This standard does not purport to address all of the safety concerns, if any, associated with its use. It is the responsibility of the user of this standard to establish appropriate safety and health practices and determine the applicability of regulatory limitations prior to use.*

¹ This test method is under the jurisdiction of ASTM Committee D20 on Plastics and is the direct responsibility of Subcommittee D20.30 on Thermal Properties (Section D20.30.07).

Current edition approved April 10, 2003. Published June 2003. Originally approved in 1942. Last previous edition approved in 1998 as D 696 – 98.

2. Referenced Documents

2.1 ASTM Standards:

D 618 Practice for Conditioning Plastics for Testing²

D 883 Terminology Relating to Plastics²

D 4065 Practice for Determining and Reporting Dynamic Mechanical Properties of Plastics³

E 228 Test Method for Linear Thermal Expansion of Solid Materials with a Vitreous Silica Dilatometer⁴

E 691 Practice for Conducting an Interlaboratory Study to Determine the Precision of a Test Method⁴

E 831 Test Method for Linear Thermal Expansion of Solid Materials by Thermomechanical Analysis⁴

3. Terminology

3.1 *Definitions*—Definitions are in accordance with Terminology D 883 unless otherwise specified.

4. Summary of Test Method

4.1 This test method is intended to provide a means of determining the coefficient of linear thermal expansion of plastics which are not distorted or indented by the thrust of the dilatometer on the specimen. For materials that indent, see 8.4. The specimen is placed at the bottom of the outer dilatometer tube with the inner one resting on it. The measuring device which is firmly attached to the outer tube is in contact with the top of the inner tube and indicates variations in the length of the specimen with changes in temperature. Temperature changes are brought about by immersing the outer tube in a liquid bath or other controlled temperature environment maintained at the desired temperature.

5. Significance and Use

5.1 The coefficient of linear thermal expansion, α , between temperatures T_1 and T_2 for a specimen whose length is L_0 at the reference temperature, is given by the following equation:

$$\alpha = (L_2 - L_1) / [L_0(T_2 - T_1)] = \Delta L / L_0 \Delta T$$

² *Annual Book of ASTM Standards*, Vol 08.01.

³ *Annual Book of ASTM Standards*, Vol 08.02.

⁴ *Annual Book of ASTM Standards*, Vol 14.02.

*A Summary of Changes section appears at the end of this standard.

where L_1 and L_2 are the specimen lengths at temperatures T_1 and T_2 , respectively. α is, therefore, obtained by dividing the linear expansion per unit length by the change in temperature.

5.2 The nature of most plastics and the construction of the dilatometer make -30 to $+30^\circ\text{C}$ [-22°F to $+54^\circ\text{F}$] a convenient temperature range for linear thermal expansion measurements of plastics. This range covers the temperatures in which plastics are most commonly used. Where testing outside of this temperature range or when linear thermal expansion characteristics of a particular plastic are not known through this temperature range, particular attention shall be paid to the factors mentioned in 1.2 and special preliminary investigations by thermo-mechanical analysis, such as that prescribed in Practice D 4065 for the location of transition temperatures, may be required to avoid excessive error. Other ways of locating phase changes or transition temperatures using the dilatometer itself may be employed to cover the range of temperatures in question by using smaller steps than 30°C [54°F] or by observing the rate of expansion during a steady rise in temperature of the specimen. Once such a transition point has been located, a separate coefficient of expansion for a temperature range below and above the transition point shall

be determined. For specification and comparison purposes, the range from -30°C to $+30^\circ\text{C}$ [-22°F to $+86^\circ\text{F}$] (provided it is known that no transition exists in this range) shall be used.

6. Apparatus

6.1 *Fused-Quartz-Tube Dilatometer* suitable for this test method is illustrated in Fig. 1. A clearance of approximately 1 mm is allowed between the inner and outer tubes.

6.2 *Device* for measuring the changes in length (dial gage, LVDT, or the equivalent) is fixed on the mounting fixture so that its position may be adjusted to accommodate specimens of varying length (see 8.2). The accuracy shall be such that the error of indication will not exceed $\pm 1.0 \mu\text{m}$ [4×10^{-5} in.] for any length change. The weight of the inner silica tube plus the measuring device reaction shall not exert a stress of more than 70 kPa [10 psi] on the specimen so that the specimen is not distorted or appreciably indented.

6.3 *Scale or Caliper* capable of measuring the initial length of the specimen with an accuracy of $\pm 0.5\%$.

6.4 *Controlled Temperature Environment* to control the temperature of the specimen. Arrange the bath so a uniform temperature is assured over the length of the specimen. Means

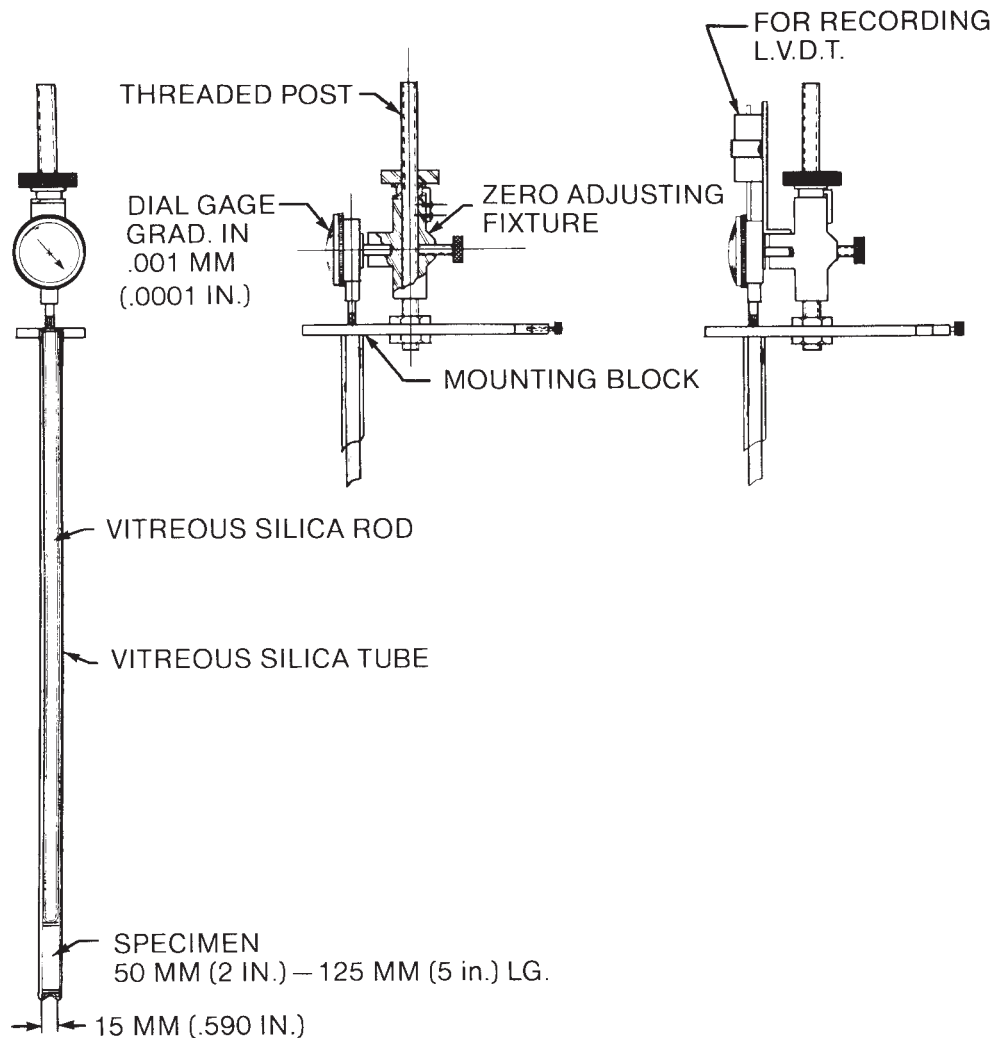

FIG. 1 Quartz-Tube Dilatometer

shall be provided for stirring the bath and for controlling its temperature within $\pm 0.2^{\circ}\text{C}$ [$\pm 0.4^{\circ}\text{F}$] at the time of the temperature and measuring device readings.

NOTE 2—If a fluid bath is used, it is preferable and not difficult to avoid contact between the bath liquid and the test specimen. If such contact is unavoidable, take care to select a fluid that will not affect the physical properties of the material under test.

6.5 Thermometer or Thermocouple—The bath temperature shall be measured by a thermometer or thermocouple capable of an accuracy of $\pm 0.1^{\circ}\text{C}$ [$\pm 0.2^{\circ}\text{F}$].

7. Sampling

7.1 Sampling shall be conducted in accordance with the material specification for the material in question.

8. Test Specimen

8.1 The test specimens shall be prepared under conditions that give a minimum of strain or anisotropy, such as machining, molding, or casting operations.

8.2 The specimen length shall be between 50 mm and 125 mm.

NOTE 3—If specimens shorter than 50 mm are used, a loss in sensitivity results. If specimens greatly longer than 125 mm are used, the temperature gradient along the specimen may become difficult to control within the prescribed limits. The length used will be governed by the sensitivity and range of the measuring device, the extension expected and the accuracy desired. Generally speaking, the longer the specimen and the more sensitive the measuring device, the more accurate will be the determination if the temperature is well controlled.

8.3 The cross section of the test specimen may be round, square, or rectangular and shall fit easily into the measurement system of the dilatometer without excessive play on the one hand or friction on the other. The cross section of the specimen shall be large enough so that no bending or twisting of the specimen occurs. Convenient specimen cross sections are: 12.5 by 6.3 mm [$\frac{1}{2}$ in. by $\frac{1}{4}$ in.], 12.5 by 3 mm [$\frac{1}{2}$ by $\frac{1}{8}$ in.], 12.5 mm [$\frac{1}{2}$ in.] in diameter or 6.3 mm [$\frac{1}{4}$ in.] in diameter. If excessive play is found with some of the thinner specimen, guide sections shall be cemented or otherwise attached to the sides of the specimen to fill out the space.

8.4 Cut the ends of the specimens flat and perpendicular to the length axis of the specimen. If a specimen indents from the use of the dilatometer, then flat, thin steel or aluminum plates shall be cemented or otherwise firmly attached to the specimen to aid in positioning it in the dilatometer. These plates shall be 0.3 to 0.5 mm [0.012 to 0.020 in.] in thickness.

9. Conditioning

9.1 **Conditioning**—Condition the test specimens at $23 \pm 2^{\circ}\text{C}$ [$73.4 \pm 3.6^{\circ}\text{F}$] and $50 \pm 5\%$ relative humidity for not less than 40 h prior to test in accordance with Procedure A of Practice D 618 unless otherwise specified by the contract or relevant material specification. In cases of disagreement, the tolerances shall be $\pm 1^{\circ}\text{C}$ [$\pm 1.8^{\circ}\text{F}$] and $\pm 2\%$ relative humidity.

9.2 **Test Conditions**—Conduct tests in the Standard Laboratory Atmosphere of $23 \pm 2^{\circ}\text{C}$ [$73.4 \pm 3.6^{\circ}\text{F}$] and $50 \pm 5\%$ relative humidity, unless otherwise specified by the contract or

relevant material specification. In cases of disagreement, the tolerances shall be $\pm 1^{\circ}\text{C}$ [$\pm 1.8^{\circ}\text{F}$] and $\pm 2\%$ relative humidity.

10. Procedure

10.1 Measure the length of two conditioned specimens at room temperature to the nearest 25 μm [0.001 in.] with the scale or caliper (see 6.3).

10.2 Cement or otherwise attach the steel plates to the ends of the specimen to prevent indentation (see 8.4). Measure the new lengths of the specimens.

10.3 Mount each specimen in a dilatometer. Carefully install the dilatometer in the -30°C [-22°F] controlled environment. If liquid bath is used, make sure the top of the specimen is at least 50 mm [2 in.] below the liquid level of the bath. Maintain the temperature of the bath in the range from -32°C to -28°C [-26 to -18°F] $\pm 0.2^{\circ}\text{C}$ [0.4°F] until the temperature of the specimen along the length is constant as denoted by no further movement indicated by the measuring device over a period of 5 to 10 min. Record the actual temperature and the measuring device reading.

10.4 Without disturbing or jarring the dilatometer, change to the $+30^{\circ}\text{C}$ [$+86^{\circ}\text{F}$] bath, so that the top of the specimen is at least 50 mm [2 in.] below the liquid level of the bath. Maintain the temperature of the bath in the range from $+28$ to 32°C [$+82$ to 90°F] $\pm 0.2^{\circ}\text{C}$ [$\pm 0.4^{\circ}\text{F}$] until the temperature of the specimen reaches that of the bath as denoted by no further changes in the measuring device reading over a period of 5 to 10 min. Record the actual temperature and the measuring device reading.

10.5 Without disturbing or jarring the dilatometer, change to -30°C [-22°F] and repeat the procedure in 10.3.

NOTE 4—It is convenient to use alternately two baths at the proper temperatures. Great care should be taken not to disturb the apparatus during the transfer of baths. Tall Thermos bottles have been successfully used. The use of two baths is preferred because this will reduce the time required to bring the specimen to the desired temperature. The test should be conducted in as short a time as possible to avoid changes in physical properties during long exposures to high and low temperatures that might possibly take place.

10.6 Measure the final length of the specimen at room temperature.

10.7 If the change in length per degree of temperature difference due to heating does not agree with the change in length per degree due to cooling within 10 % of their average, investigate the cause of the discrepancy and, if possible, eliminate. Repeat the test until agreement is reached.

11. Calculation

11.1 Calculate the coefficient of linear thermal expansion over the temperature range used as follows:

$$\alpha = \Delta L / L_0 \Delta T$$

- α = average coefficient of linear thermal expansion per degree Celsius,
 ΔL = change in length of test specimen due to heating or to cooling,

L_0 = length of test specimen at room temperature (ΔL and L_0 being measured in the same units), and
 ΔT = temperature differences, °C, over which the change in the length of the specimen is measured.

The values of α for heating and for cooling shall be averaged to give the value to be reported.

NOTE 5—Correction for thermal expansion of silica is 4.3×10^{-7} 1°C. If requested, this value should be added to the calculated value to compensate for the expansion of the apparatus equivalent to the length of the specimen. If thick metal plates are used, appropriate correction may also be desirable for their thermal expansions.

12. Report

12.1 The report shall include the following:

- 12.1.1 Designation of material, including name of manufacturer and information on composition when known.
- 12.1.2 Method of preparation of test specimen,
- 12.1.3 Form and dimensions of test specimen,
- 12.1.4 Type of apparatus used,
- 12.1.5 Temperatures between which the coefficient of linear thermal expansion has been determined,
- 12.1.6 Average coefficient of linear thermal expansion per degree Celsius, for the two specimens tested.
- 12.1.7 Location of phase change or transition point temperatures, if this is in the range of temperatures used,
- 12.1.8 Complete description of any unusual behavior of the specimen, for example, differences of more than 10 % in measured values of expansion and contraction.

13. Precision and Bias

13.1 Table 1 is based on a round robin conducted in 1989 in accordance with Practice E 691 involving nine materials and five laboratories. For each material, all samples are prepared at one source, but the individual specimens are prepared at the laboratory that tested them. Each test result is the average of two individual determinations. Each laboratory obtained one test result for each material. **Warning**—The explanations of “ r ” and “ R ” (13.2-13.2.3) only are intended to present a meaningful way of considering the approximate precision of this test method. The data presented in Table 1 should not be applied to the acceptance or rejection of materials, as these data apply only to the materials tested in the round robin and are unlikely to be rigorously representative of other lots, formulations, conditions, materials, or laboratories. In particular, with data from less than six laboratories, the between laboratories results are likely to have a very high degree of error. Users of this test method should apply the principles outlined in Practice E 691 to generate data specific to their materials and labora-

TABLE 1 Coefficient of Linear Expansion, 10^{-6}

Material	Average	S_r^A	S_R^B	r^C	R^D	No. of Participating Laboratories
Polyester-Glass	24.7	1.80	4.91	5.04	13.75	5
Phenolic-Glass	34.2	1.18	2.63	3.29	7.36	5
Epoxy-Glass	26.1	1.27	2.74	3.55	7.69	5
Polypropylene	158.2	3.38	12.20	9.47	34.20	5
Polyethylene	63.0	0.454	1.73	1.27	4.80	5
Polycarbonate	113.0	2.48	4.77	6.95	13.36	5
Nylon 66	130.7	2.83	7.63	7.92	21.4	5
PTFE	207.0	18.7	42.7	52.4	119.5	4
Expanded Polypropylene Beads, Density 4.40 PCF	117.2	16.7	25.9	46.8	72.5	4

^A S_r = within-laboratory standard deviation for the indicated material. It is obtained by pooling the within-laboratory standard deviations of the test result from all the participating laboratories:

$$S_r = \{[(S_1)^2 + (S_2)^2 + \dots + (S_n)^2]/n\}^{1/2}$$

^B S_R = between-laboratories reproducibility, expressed as standard deviation:
 $S_R = (S_1^2 + S_2^2)^{1/2}$

^C r = within-laboratory critical interval between two test results = $2.8 \times S_r$

^D R = between laboratories critical interval between two test results = $2.8 \times S_R$

tory, or between specific laboratories. The principles of 13.2-13.2.3 then would be valid for such data.

13.2 *Concept of “ r ” and “ R ” in Table 1*—If S_r and S_R have been calculated from a large enough body of data, and for test results that are averages from testing five specimens for each test result, then the following applies:

13.2.1 Repeatability “ r ” is the interval representing the critical difference between two test results for the same material, obtained by the same operator using the same equipment on the same day in the same laboratory. Two test results shall be judged not equivalent if they differ by more than the “ r ” value for that material.

13.2.2 Reproducibility “ R ” is the interval representing the critical difference between two test results for the same material, obtained by different operators using different equipment in different laboratories, not necessarily on the same day. Two tests results shall be judged to be judged not equivalent if they differ by more than the “ R ” value for that material.

13.2.3 Any judgement in accordance with 13.2.1 or 13.2.2 would have an approximate 95 % (0.95) probability of being correct.

13.3 There are no recognized plastic reference materials to estimate bias of this test method; however, there are recognized metal and ceramic reference materials.

14. Keywords

14.1 coefficient of expansion; linear expansion; plastics; thermal expansion

SUMMARY OF CHANGES

This section identifies the location of selected changes to this test method. For the convenience of the user, Committee D20 has highlighted those changes that may impact the use of this test method. This section may also include descriptions of the changes or reasons for the changes, or both.

D 696 – 03:

- (1) Removed permissive language throughout.
- (2) Revised paragraph 8.4.
- (3) Removed Practice D 1898 from Referenced Documents. There is no reference to it within the standard and it has been withdrawn.

D 696 – 98:

- (1) Change in title to add “With a Vitreous Silica Dilatometer.”
- (2) Addition of Note 1.
- (3) Updated Section 9.
- (4) Updated Section 13.
- (5) Added Summary of Changes section.

ASTM International takes no position respecting the validity of any patent rights asserted in connection with any item mentioned in this standard. Users of this standard are expressly advised that determination of the validity of any such patent rights, and the risk of infringement of such rights, are entirely their own responsibility.

This standard is subject to revision at any time by the responsible technical committee and must be reviewed every five years and if not revised, either reapproved or withdrawn. Your comments are invited either for revision of this standard or for additional standards and should be addressed to ASTM International Headquarters. Your comments will receive careful consideration at a meeting of the responsible technical committee, which you may attend. If you feel that your comments have not received a fair hearing you should make your views known to the ASTM Committee on Standards, at the address shown below.

This standard is copyrighted by ASTM International, 100 Barr Harbor Drive, PO Box C700, West Conshohocken, PA 19428-2959, United States. Individual reprints (single or multiple copies) of this standard may be obtained by contacting ASTM at the above address or at 610-832-9585 (phone), 610-832-9555 (fax), or service@astm.org (e-mail); or through the ASTM website (www.astm.org).