



Designation: D 3291 – 97

Standard Practice for Compatibility of Plasticizers in Poly(Vinyl Chloride) Plastics Under Compression¹

This standard is issued under the fixed designation D 3291; the number immediately following the designation indicates the year of original adoption or, in the case of revision, the year of last revision. A number in parentheses indicates the year of last reapproval. A superscript epsilon (ϵ) indicates an editorial change since the last revision or reapproval.

1. Scope *

1.1 This practice determines the compatibility of plasticizers in poly(vinyl chloride) plastics by rating the amount of plasticizer that spews due to compressional stress set up inside a 180° loop bend.

NOTE 1—Ingredients other than plasticizer can spew from a total formulation.

1.2 The text of this practice references notes and footnotes that provide explanatory material. These notes and footnotes (excluding those in tables and figures) shall not be considered as requirements of this practice.

1.3 The values as stated in SI units are to be regarded as the standard. The values in parentheses are given for information only.

1.4 *This standard does not purport to address all of the safety concerns, if any, associated with its use. It is the responsibility of the user of this standard to establish appropriate safety and health practices and determine the applicability of regulatory limitations prior to use.*

NOTE 2—There are no ISO standards covering the primary subject of this practice.

2. Referenced Documents

2.1 ASTM Standards:

D 883 Terminology Relating to Plastics²

D 1600 Terminology for Abbreviated Terms Relating to Plastics²

3. Terminology

3.1 *General*—Definitions are in accordance with Terminology D 883 and abbreviations with Terminology D 1600, unless otherwise indicated.

4. Summary of Practice

4.1 Test specimens of plasticized poly(vinyl chloride) sheet

are bent through an arc of approximately 180°. The inner radius of the bend is equal to the thickness of the specimen. These bent specimens are secured in a jig designed to hold them in the desired conformation. At specified intervals of time, a specimen is removed, bent 360° in the opposite direction, and the former inside of the loop (now the outside) is examined for evidence of plasticizer spew.

5. Significance and Use

5.1 Plasticizers may become less compatible in poly(vinyl chloride) resin when fused compound is subjected to compressive stress.

5.1.1 This test subjects a standard test specimen to a definite deformation and allows qualitative determination of the amount of spew which may occur over a period of time.

5.1.2 An apparent decrease in compatibility of plasticizers with subsequent exudation can cause excessive dirt pickup, marring of lacquered or varnished surfaces, sticky feel, and a number of other associated problems.

5.1.3 When a plasticized poly(vinyl chloride) sheet is stressed in compression by bending it through 180°, the stress may be relieved by migration of the plasticizer from the compressed area (inside of bend) to the area in tension (outside of bend). If these compressive stresses cannot be relieved rapidly by internal migration of plasticizer, then plasticizer will spew. The internal migration of plasticizer will continue and when a deficiency of plasticizer occurs at the compressed area spewed plasticizer will be reabsorbed. Certain plasticizers may spew and be reabsorbed quite rapidly. Less compatible plasticizers may spew early and continue to spew throughout the test. A test of one week's duration is used for screening, while an extended test of seven weeks' duration is used for a complete profile.

NOTE 3—Other test conditions of time, temperature, or relative humidity may be agreed upon between the seller and the purchaser.

6. Apparatus

6.1 *Bending Test Jig*, as shown in Fig. 1.

¹ This practice is under the jurisdiction of ASTM Committee D-20 on Plastics and is the direct responsibility of Subcommittee D20.15 on Thermoplastic Materials (Section D20.15.07).

Current edition approved July 10, 1997. Published April 1998. Originally published as D 3291 – 74. Last previous edition D 3291 – 92.

² *Annual Book of ASTM Standards*, Vols 08.01 and 08.04.

*A Summary of Changes section appears at the end of this standard.

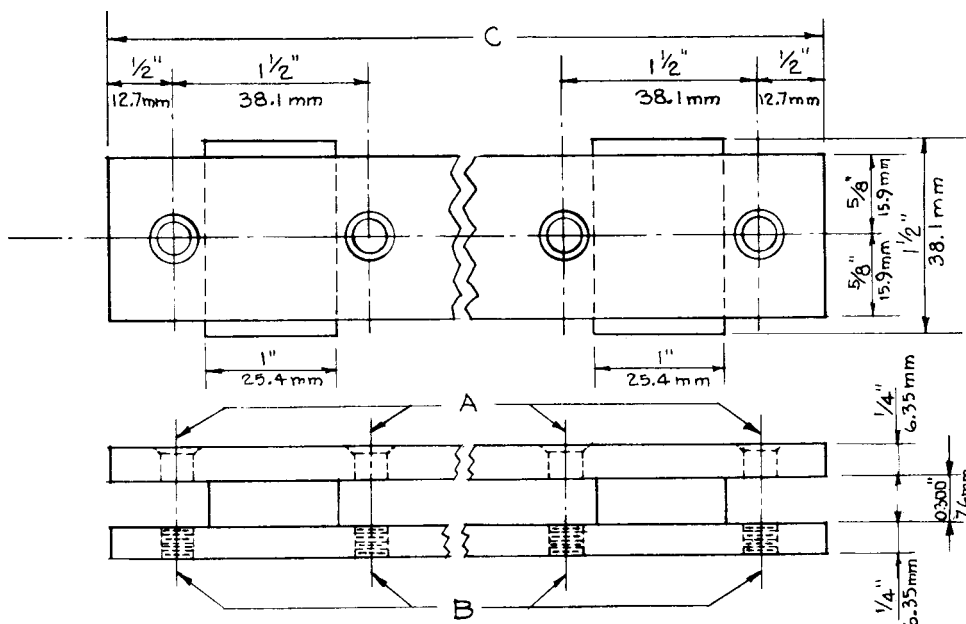

- A Drill and countersink for 6.35-mm (1/4-in.) flat head machine screw
 - B Drill and tap to receive 6.35-mm (1/4-in.) machine screw
 - C May be any convenient length up to 457 mm (18 in.)
- Material—Oil-hardening precision ground tool and die steel

FIG. 1 Bending Test Jig

6.2 *Cigarette Papers*, cut in half to be approximately square.³

7. Specimen Preparation

7.1 Cut test specimens 12.7 by 25.4 mm (1/2 by 1 in.) from a plasticized poly(vinyl chloride) sheet 1.9 ± 0.1 mm (0.075 ± 0.005 in.) thick, taking care to ensure the long edges are parallel.

NOTE 4—Optimum fusion conditions of temperature and time vary with plasticizer and resin type as well as other additives. The processing conditions must be agreed upon by the seller and the purchaser.

8. Conditioning

8.1 Test specimens shall be conditioned at $23 \pm 2^\circ\text{C}$ (73.4

$\pm 3.6^\circ\text{F}$) and $50 \pm 5\%$ relative humidity for 24 h prior to testing.

9. Procedure

9.1 Fold the conditioned specimens in half, short ends together and place the loop end in the jig with the spacer bar equal to four times the nominal specimen thickness—7.6 mm (0.300 in.)—as shown in Fig. 2. Leave about 4.75 mm ($3/16$ in.) of the ends outside jig. The loop inside the jig should be smooth and continuous and no evidence of cracking should be seen on the outside of the loop.

NOTE 5—Specimen must be thoroughly fused to give meaningful results. Collapse of the loop is one indication of incomplete fusion.

9.2 Mark the time of starting the test.

9.3 Place the loop jig containing the specimens in the

³ An example of a satisfactory brand is white OCB paper from Reynolds.

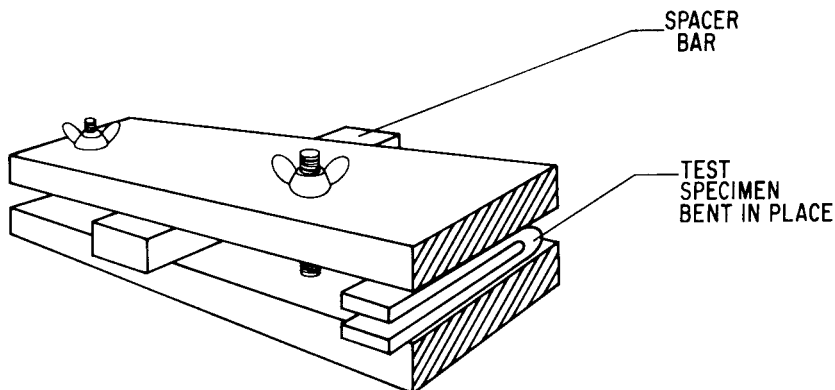

Not To Scale

FIG. 2 Perspective Drawing Showing Sample Mounted in Jig



chamber at $23 \pm 2^\circ\text{C}$ ($73.4 \pm 3.6^\circ\text{F}$) and $50 \pm 5\%$ relative humidity.

9.4 Test individual specimens for 4 h, 24 h, and 7 days.

9.5 At the end of the testing period, remove a specimen from the jig and fold the loop in the opposite direction around index finger, so that the inside of the loop in the jig is now outside. Examine the loop area for evidence of spew by wiping the loop area thoroughly with a cigarette paper held around a clean, *dry* finger.

9.6 Rate spew according to the appearance of the cigarette paper immediately after wiping.

9.7 Subject those specimens which show exudation after the 7-day test period to long-term testing by repeating 8.1-9.6. Start seven specimens together with examination of one specimen each week for 7 weeks.

10. Interpretation of Results

10.1 Assign a rating in accordance with the following:

Description of Cigarette Paper	Amount of Exudation	Grading
No mark on paper or visible evidence in loop.	none	0
Oily mark on paper very faint and discontinuous.	slight	1
Wetted area may appear saturated in small spots, although much of it is not saturated.	moderate	2

Total wetted area is saturated by continuous heavy/dripping 3
film. Large puddle of plasticizer over entire
wetted area.

11. Report

11.1 Report the following information:

11.1.1 Description of the sample, and

11.1.2 Ratings for each time period.

12. Precision and Bias ⁴

12.1 *Reproducibility*—Multilaboratory test results on specimens prepared in a single laboratory are reproducible to within ± 1.0 grading unit at two standard deviations when the specimens are actually 1 or 2. If specimens are actually 0 or 3, practically all tests agreed exactly.

12.2 *Bias*—The bias has not been determined.

13. Keywords

13.1 plasticizer compatibility; plasticizers; poly(vinyl chloride)

⁴ Round-robin data for this practice are available from ASTM Headquarters. Request RR: D20-1037.

SUMMARY OF CHANGES

Committee D-20 has identified the location of selected changes to this edition of this practice since the last issue that may impact the use of this practice.

D 3291 – 97:

(1) Section 1.2 added.

ASTM International takes no position respecting the validity of any patent rights asserted in connection with any item mentioned in this standard. Users of this standard are expressly advised that determination of the validity of any such patent rights, and the risk of infringement of such rights, are entirely their own responsibility.

This standard is subject to revision at any time by the responsible technical committee and must be reviewed every five years and if not revised, either reapproved or withdrawn. Your comments are invited either for revision of this standard or for additional standards and should be addressed to ASTM International Headquarters. Your comments will receive careful consideration at a meeting of the responsible technical committee, which you may attend. If you feel that your comments have not received a fair hearing you should make your views known to the ASTM Committee on Standards, at the address shown below.

This standard is copyrighted by ASTM International, 100 Barr Harbor Drive, PO Box C700, West Conshohocken, PA 19428-2959, United States. Individual reprints (single or multiple copies) of this standard may be obtained by contacting ASTM at the above address or at 610-832-9585 (phone), 610-832-9555 (fax), or service@astm.org (e-mail); or through the ASTM website (www.astm.org).