



Designation: D 3294 – 97

Standard Specification for Polytetrafluoroethylene (PTFE) Resin Molded Sheet and Molded Basic Shapes¹

This standard is issued under the fixed designation D 3294; the number immediately following the designation indicates the year of original adoption or, in the case of revision, the year of last revision. A number in parentheses indicates the year of last reapproval. A superscript epsilon (ϵ) indicates an editorial change since the last revision or reapproval.

1. Scope *

1.1 This specification establishes requirements and methods of test for the material, dimensions, and workmanship, and the physical and electrical properties of molded sheet in minimum thicknesses of 0.794 mm ($1/32$ in.) manufactured from PTFE resin molding materials.

1.2 This specification also establishes requirements for molded basic shapes made from resin molding and extrusion materials. This specification is for products 300 mm (12 in.) or less in a dimension parallel to and 12.7 mm (0.5 in.) or greater in the dimension perpendicular to the direction of the applied molding pressure.

1.3 The values stated in SI units are to be regarded as the standard.

1.4 The following precautionary caveat pertains only to the test method portion, Section 7, of this specification. *This standard does not purport to address all of the safety concerns, if any, associated with its use. It is the responsibility of the user of this standard to establish appropriate safety and health practices and determine the applicability of regulatory limitations prior to use.* Special attention is called to 13.2, 13.3, 13.6, 13.8, and A1.

NOTE 1—There is no similar or equivalent ISO standard.

2. Referenced Documents

2.1 ASTM Standards:

- D 149 Test Method for Dielectric Breakdown Voltage and Dielectric Strength of Solid Electrical Insulating Materials at Commercial Power Frequencies²
- D 618 Practice for Conditioning Plastics and Electrical Insulating Materials for Testing³
- D 638 Test Method for Tensile Properties of Plastics³
- D 792 Test Methods for Specific Gravity (Relative Density)

¹ This specification is under the jurisdiction of ASTM Committee D-20 on Plastics, and is the direct responsibility of Subcommittee D20.15 on Thermoplastic Materials (Section D20.15.12).

Current edition approved Sept. 10, 1997. Published April 1998. Originally published as D 3294 – 74. Last previous edition D 3294 – 91a.

This revision combines Specification D 3293 and Specification D 3294. Specification D 3293 has been withdrawn. A complete summary of changes is given at the end of the text.

² *Annual Book of ASTM Standards*, Vol 10.02.

³ *Annual Book of ASTM Standards*, Vol 08.01.

- and Density of Plastics by Displacement³
- D 883 Terminology Relating to Plastics³
- D 1505 Test Method for Density of Plastics by the Density-Gradient Technique³
- D 1600 Terminology for Abbreviated Terms Relating to Plastics³
- D 1708 Test Method for Tensile Properties of Plastics by Use of Microtensile Specimens³
- D 1898 Practice for Sampling of Plastics³
- D 3293 Specification for PTFE Resin Molded Sheet⁴
- D 3892 Practice for Packaging/Packing of Plastics⁴
- D 4591 Test Method for Determining Temperatures and Heats of Transitions of Fluoropolymers by Differential Scanning Calorimetry⁵
- E 94 Guide for Radiographic Testing⁶

3. Terminology

3.1 Definitions:

3.1.1 Definitions are in accordance with Terminology D 883 unless otherwise specified.

3.1.2 *lot, n*—one continuous production run or a uniform blend of two or more production runs of one size sheet or molded basic shape.

3.2 Abbreviations:

3.2.1 Abbreviations are in accordance with Terminology D 1600. PTFE is the abbreviation for polytetrafluoroethylene.

4. Classification

4.1 This specification covers the following three types of molded basic sheets and shapes:

4.1.1 *Type I*—Premium; normally used for exacting electrical, mechanical, or chemical applications.

4.1.2 *Type II*—General purpose; for electrical, mechanical, and chemical applications not requiring premium material.

4.1.3 *Type III*—Mechanical Grade; for noncritical chemical, electrical, and mechanical applications.

4.1.4 *Type IV*—Utility; having no electrical requirements and with mechanical properties at a lower level.

4.2 Types I, II, and III may be subdivided into two grades as follows:

⁴ *Annual Book of ASTM Standards*, Vol 08.02.

⁵ *Annual Book of ASTM Standards*, Vol 08.03.

⁶ *Annual Book of ASTM Standards*, Vol 03.03.

***A Summary of Changes section appears at the end of this standard.**



4.2.1 *Grade 1*—made only from virgin resin.
 4.2.2 *Grade 2*—may be made using reprocessed resin.
 4.3 The grades may be further subdivided into three classes as follows:

4.3.1 *Class A*—resistant to thermal dimensional change not exceeding 0.5 %.

4.3.2 *Class B*—thermal dimensional change not exceeding 5.0 %.

4.3.3 *Class C*—thermal dimensional change may exceed 5.0 %.

4.4 A one-line system may be used to specify materials covered by this specification. The system uses predefined cells to refer to specific aspects of this specification, as illustrated below.

Specification				
Standard Number Block	Type	Grade	Class	Special Notes
:	:	:	:	:

Example: Specification D 3294 – 97, I I A

For this example, the line callout would be Specification D 3294 – 97,11A and would specify premium virgin form of polytetrafluoroethylene that has all of the properties listed for that Type, Grade, and Class in the appropriate specified properties, tables, or both, in the specification identified. A comma is used as the separator between the standard Number and the Type. Separators are not needed between the Type, Grade, and Class.⁷ Provision for Special Notes is included so that other information can be provided when required. An example would be in Specification D 3295 where dimensions and tolerances are specified for each AWG size within Type and Class. When Special Notes are used, they should be preceded by a comma.

5. Ordering Information

5.1 The molded sheet or basic shapes covered in this specification shall be ordered stating the type, grade, and class and that they meet the requirements of this specification.

6. Materials

6.1 The sheet or molded basic shape from Types I, II, III, or IV shall be made from unpigmented PTFE as free of foreign matter as commercially practical.

7. Requirements

7.1 The sheet covered by this specification shall meet the physical and electrical requirements specified in Table 1 and paragraph 7.1.1 when tested by the methods given in Section 13.

7.2 The molded basic shapes covered by this specification shall meet the physical and electrical requirements specified in Table 2 and 7.1.1 when tested by the test methods given in Section 13.

7.2.1 *Melting Point*—the melting point of all types of sheet and molded basic shapes shall be $327 \pm 10^\circ\text{C}$ when tested in accordance with paragraph 13.8.

TABLE 1 Physical and Electrical Requirements for PTFE Sheets^A

Types	Tensile Strength ^A (min) psi	Elongation ^A (min) Percent	Dielectric Strength ^B (min) Volts Per Mill	Specific Gravity ^C	Porosity ^D
I	4500	300	600	2.15 to 2.18 ^E	Zero penetration
II	3000	225	500	2.14 to 2.19	Not required
III	2000	150	300	2.13 to 2.19	Not required
IV	1300	75	Not required	2.13 to 2.20	Not required

^A See 13.2.

^B See 13.3.

^C See 13.4.

^D See 13.6.

^E PTFE sheet used for tank lining shall be Type I but shall have a specific gravity of 2.19 to 2.22.

TABLE 2 Physical and Electrical Requirements for Basic Shapes

Types	Tensile Strength psi (min)	Elongation % (min)	Dielectric Strength Volts per mil (min)	Specific Gravity
I	4800	325	1200	2.14 to 2.18
II	3200	240	850	2.14 to 2.19
III	1500	75	250	2.13 to 2.20

8. Dimensions

8.1 The size, shape, dimensional tolerances, and dimensional stability shall be as specified in the contract or order.

8.2 The tolerance on length and width shall be plus 6.3 mm (¼ in.), minus 0 mm (in.).

9. Workmanship, Finish, and Appearance

9.1 *Color*—Type I shall be white to translucent, but may have occasional spots. Types II, III, and IV are typically white, but may vary to light gray or light brown. For Types II, III, and IV occasional small gray, brown, or black spots shall not be considered as cause for rejection.

9.2 *Finish*—The material shall be as free as is commercially practical from surface blisters, wrinkles, cracks and other surface defects that might affect its serviceability. It shall also be commercially free of macroscopic voids, cracks, and foreign inclusions.

9.3 *Internal Defects*—The moldings shall be as free as is commercially practical of microscopic voids, cracks, and foreign inclusions.

10. Sampling

10.1 For purposes of sampling, an inspection lot for examination and tests shall consist of all material of the same type, grade, and class and nominal size submitted for inspection at one time.

10.2 The total quantity of sheet or basic shapes to be taken from each lot shall be approximately twice that estimated to be required for the tests that are to be made, in order to permit repeat tests without resampling.

10.3 The sheet or basic shapes selected for sampling may be chosen at random from each lot. If the shipment consists of more than one lot or “run” of material, each lot shall be sampled separately. The average result of the specimens tested shall conform to the requirements specified in this specification.

⁷ See the ASTM *Form and Style Manual*. Available from ASTM Headquarters.

11. Number of Tests

11.1 Routine lot inspection tests shall consist of all the tests specified in Table 1, Table 2, or Table 3.

11.2 The tests listed in Table 1 and Table 2, as they apply, are sufficient to establish conformity of the PTFE sheet or basic shapes to this specification. When the number of test specimens is not stated in the test method, single determination may be made. If more than single determinations and separate portions of the same sample are made, the results shall be averaged. The single or average result shall conform to the requirements prescribed in this specification.

11.3 The properties listed in the Appendix X1 provide additional information. The data shown are informational only and should not be used for specification purposes.

12. Test Conditions

12.1 *Conditioning of Specimens*—Unless otherwise specified in this specification, the test specimens shall be conditioned in accordance with Procedure A of Practice D 618 for a period of at least four h prior to test.

12.2 *Standard Temperature*—Unless otherwise specified, the tests shall be conducted at the standard laboratory temperature of $23^{\circ}\text{C} \pm 1^{\circ}\text{C}$ ($73.4^{\circ}\text{C} \pm 1.8^{\circ}\text{F}$). Since the sheet or molded basic shape does not absorb water, the maintenance of constant humidity during testing is not important.

13. Test Methods

13.1 *Visual and Dimensional Inspection*—Each of the sample PTFE sheets or molded basic shapes selected in accordance with Section 10 shall be visually and dimensionally inspected to verify their compliance with the requirements of the standard. Occasional superficial flaws in PTFE sheet or molded basic shapes should be interpreted as neither affecting the porosity nor soundness of the molding. Such flaws are scratches, edge cracks, and the adherence of resin flakes. Such indications shall not be cause for rejection.

13.2 *Tensile Strength and Elongation*—Determine the ultimate tensile strength and elongation in accordance with Test Method D 638 except as follows:

13.2.1 Cut five microspecimens with the steel rule die and the dimensions shown in Fig. 1 using a hydraulic or mechanical press. When cutting a specimen, back it by a hard surface board such as masonite or equal with a piece of thin cardboard such as that used in a tabulating machine between said hard

surface and sample. Remove any tool marks resulting from sample preparation which are not essentially parallel to the long axis of the specimen by light sanding in a direction parallel to such long axis.

13.2.2 Testing shall be at a speed of 50.8 mm (2 in.)/min.

13.2.3 Determine elongation by using an initial jaw separation of 22.2 mm (0.875 in.) and expressed as a percentage of the initial jaw separation.

13.2.4 *Alternative Specimens*—When the shape of the sample does not permit making the dumbbell as specified in 13.2.1 prepare specimens by turning a 0.8-mm ($1/32$ -in.) thick-walled tube from the shape, and cutting dumbbells from the tube wall in a direction perpendicular to the applied molding pressure, that is, with the long axis of the dumbbell parallel to the circumference of the tube. Lathe-turn the tube in such a manner that the specimen is taken from the center of the original wall thickness. In the case of a rod, remove the outer 1.6 mm ($1/16$ in.) before finish turning the outer diameter of the tube. Turn both inside and outside surfaces with a fine lathe feed and sharp tools to permit the smoothest possible finish.

13.2.5 Cut sheets 1.6 mm ($1/16$ in.) or under in thickness, five micro-specimens with the steel rule die and the dimensions shown in Fig. 1 using a hydraulic or mechanical press. Machine sheets thicker than 1.6 mm ($1/16$ in. and thinner than 15.9 mm ($5/8$ in.) to a thickness of 1.6 ± 0.25 mm ($1/16 \pm 0.010$ in.) and five specimens from these reduced portions. From sheets 15.9 mm ($5/8$ in.) and over in thickness, a slice somewhat thicker than 1.6 mm ($1/16$ in.) shall be cut from one edge but not less than 12.7 mm ($1/2$ in.) distance from that edge and both faces machined to a thickness of 1.6 ± 0.25 mm ($1/16 \pm 0.010$ in.). In all cases of specimens reduced to 1.6 mm ($1/16$ in.) by machining, tool marks shall be removed by light sanding in a longitudinal direction.

13.3 *Dielectric Strength*—Determine the dielectric strength in accordance with Test Method D 149 using five specimens and the short-time test under oil, except as follows:

13.3.1 When 25.4 mm (1 in.) specimens are used, the electrodes shall be 63.5 mm ($1/4$ in.) in diameter, with edges rounded to a 0.8 mm ($1/32$ in.) radius.

13.3.2 If the size of the molding does not permit 25.4 mm (1 in.) wide specimens, 12.7 mm ($1/2$ -in.) discs or strips 0.5 ± 0.05 mm (0.020 ± 0.002 in.) thick may be used with 1.6-mm ($1/16$ -in.) diameter electrodes with rounded edges.

13.3.3 The specimen must extend sufficiently far beyond the electrode edge so that a flash-over does not occur.

13.4 *Specific Gravity*—Determine the specific gravity on two specimens in accordance with Method A of Test Methods D 792. Add two drops of a wetting agent (liquid detergent)⁸ to the water in order to reduce the surface tension and insure complete wetting of the sample.

13.4.1 Use the gradient tube method, Test Method D 1505, as an alternate on three specimens.

13.5 *Porosity*—Determine the porosity of Type I sheet or molded shape by the penetrant test.

13.5.1 *Scope*—The test for porosity is to determine that the

TABLE 3 Nominal Thickness and Tolerances for PTFE Sheets

Thickness Inch	Tolerance Inch	Thickness Inch	Tolerance Inch	Thickness Inch	Tolerance Inch
$1/32$	+0.015 -0.005	$1/4$	+0.030 -0.015	$1/4$	+0.102 -0.051
$1/16$	+0.015 -0.005	$3/8$	+0.038 -0.019	$1/2$	+0.118 -0.059
$3/32$	+0.020 -0.005	$1/2$	+0.046 -0.022	$3/4$	+0.134 -0.067
$1/8$	+0.016 -0.008	$5/8$	+0.054 -0.027	2	+0.150 -0.075
$5/32$	+0.018 -0.009	$3/4$	+0.070 -0.035	Over 2	+10 % -10 %
$3/16$	+0.022 -0.011	1	+0.087 -0.043		

⁸ Examples of suitable wetting agents are “Glim” detergent, B. J. Babitt, Inc.; “Joy” detergent, Proctor and Gamble, Inc.; and “Triton” X-100, Rohm and Haas Co.

ASTM D 3294

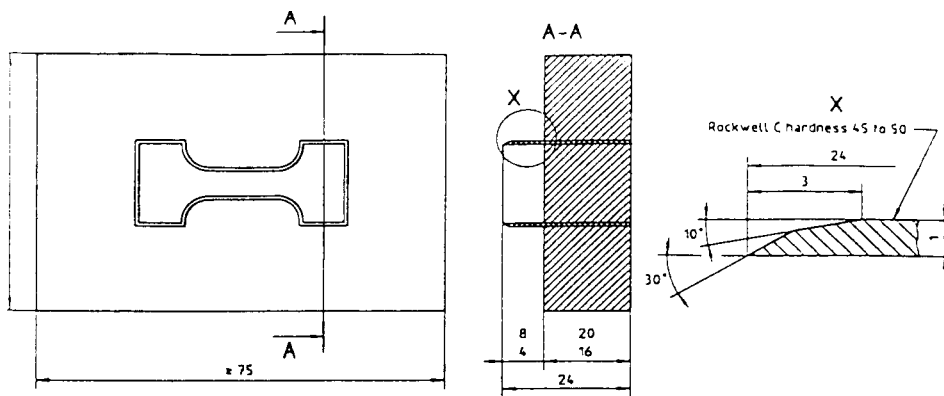

Steel-rule die
(inside dimensions for die are the same as test specimen)
Die to be sharpened on outside edge only (as shown in A-A)

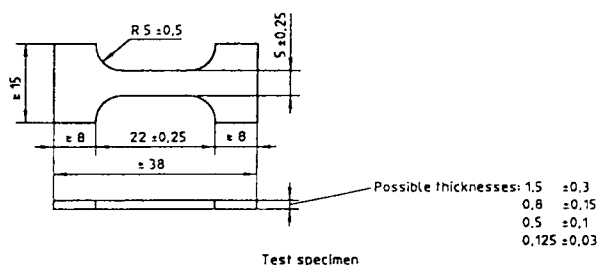

Test specimen

NOTE 1—Dimensions in millimetres.

FIG. 1 Microtensile Die—ISO

molding has received adequate pressure and temperature throughout.

13.5.2 *Significance and Use*—The significance of this test for porosity is to indicate if the molding has been properly manufactured.

13.5.3 Use one full size sheet or molding for the porosity test. Degrease the entire surface on the molding with folded paper wiping tissues wet with a suitable cleaner.⁹ Remove the excess cleaner and permit the surface to dry for at least 5 min.

13.5.4 Deposit a film of penetrant⁹ on the entire surface of the molding and allow to stand for 5 min. If the penetrant appears to dry prematurely, rewet the surface with penetrant and allow to dry for 1 min longer. Then, remove the penetrant by wiping with a tissue and scrub the entire surface thoroughly with tissues wet with cleaner.

13.5.5 When dry, inspect entire surface for indication of discoloration caused by the penetrant. Retained areas of penetrant that appear cloudy or hazy indicate porosity. Occasional superficial flaws in PTFE sheet or moldings shall not be interpreted as porosity.

13.5.6 *Precision and Bias*—The precision and bias for this penetrant-die test will be determined.

13.6 *Dimensional Stability*—Determine the thermal dimensional change of each lot of material using the method in 13.6.1-13.6.10.

13.6.1 *Scope*—The test for dimensional stability is specific to determine the amount of change of dimension when the molding is heated.

13.6.2 *Significance and Use*—The significance of this test is to indicate if the molding has been adequately stress relieved.

13.6.3 Measure the entire molding to the nearest 0.025 mm (0.001 in.) in directions of length, width, and depth of sheets and blocks, length and diameter of cylinders, and length, diameter, and wall thickness of tubes.

13.6.4 Mark the points of original measurement so that measurement after heating and cooling is made at the same points.

13.6.5 Place the molded shape or sheet in a heating chamber at a temperature of 290 ± 3°C (554 ± 5.4°F). The heating medium may be either oil or air.

13.6.6 Hold the specimen at this temperature for a time period equivalent to 2 h/6.350 mm (0.25 in.), but not less than 2 h, then lower the temperature at a rate not exceeding 30°C (54°F)/h until room temperature is reached.

13.6.7 Again measure the specimen at the same points to the nearest 0.025 mm (0.001 in.).

13.6.8 Alternatively, mark portions of the molding and measure the distances between the marks to the nearest 0.025 mm (0.001 in.) in the respective directions.

13.6.9 Calculate the change in dimensions by the following equation and average the results separately for the changes made in each direction.

$$D = (L_h - L_i)/L_i \times 100$$

⁹ Spotcheck cleaner and penetrant, available from Magnaflux Corp., 7300 W. Lawrence Ave., Chicago, IL 60656 has been found satisfactory for this purpose. Spotcheck developer is not required.



where:

D = dimensional change, % .

L_i = initial dimension of sample, and

L_h = dimension of sample after heating.

13.6.10 *Precision and Bias*—The precision and bias for this test for dimensional stability will be determined.

13.7 *Examination for Internal Defect*:

13.7.1 The general procedure of Guide E 94 shall be followed for examination for internal defects.

13.7.2 X-ray the shape in as many views as necessary to give complete coverage of the pieces. Identify all x-ray film to correspond with the shape sections, or view, so that any defects may be located afterwards.

13.7.3 View films for defects such as microscopic cracks, voids and inclusions. Check films showing apparent defects against the corresponding sample and position to make sure that these apparent defects are not due to surface contamination.

13.8 *Melting Point*—The melting point shall be determined on one specimen in accordance with Specification D 1457.

13.8.1 As an alternate, the melting point may be determined by the procedure given in Test Method D 4591.

14. Retest and Rejection

14.1 If any failure occurs, the materials may be retested to establish conformity.

14.2 The purchaser must notify the seller within three weeks of receipt of the lot, that a failure was observed.

14.3 The number of specimens used for retest shall be twice that for the original test.

15. Certification

15.1 For all Type I, Grade 1 molded basic shapes or sheet, the purchaser shall be furnished a certification that this lot is made from only virgin PTFE and that the sample representing each lot has been either tested or inspected as directed in this specification and the requirements have been met. When specified in the purchase order or contract, a report of the test results shall be furnished.

16. Identification and Marking

16.1 *Identification*—Marking of the molded sheet or basic shapes shall show the name of the material, type, grade, and class and shall give the quantity.

16.2 *Shipping Containers*—Boxes or crates shall be marked with the name of the material, type, grade, class, and lot number as well as the name and address of the supplier.

16.3 All packing, packaging, and marking provisions of Practice D 3892 shall apply to this specification.

17. Keywords

17.1 fluorocarbon polymer; fluoropolymers; granular PTFE; polytetrafluoroethylene; PTFE; PTFE basic shapes

APPENDIX

(Nonmandatory Information)

X1.

X1.1 *Dimensional Stability*—Basic shapes molded from PTFE as normally processed will contain internal stresses. The magnitude of these stresses will vary with the thickness. These stresses may result in dimensional changes when parts cut therefrom are heated or machined. Annealing the shapes may relieve some of the stresses and may distort the surface and flatness of the shapes. However, this stress-relief treatment is only partially effective. The magnitude of the residual stresses

is not uniform throughout and varies with the size. No amount of annealing will insure complete stability in the final product. The best dimensional stability in a finished product can only be accomplished by carrying out a stress-relief procedure on a finished part after all cutting operations are complete. For close tolerances on a finished part, the best procedure is to fabricate to approximate dimensions, stress relieve and then finish to specified dimensions.



TABLE X1.1 Mechanical, Physical and Chemical Properties

Property	Value	ASTM Designation	Test Methods
Dissipation Factor 1000 cycles	0.0005 max	D 150	Test for A-C Capacitance, Dielectric Constant and Loss Characteristics of Electric Insulating Materials.
Dielectric Constant 100 cycles	2.0 to 2.1	D 150	
Volume Resistivity	Over 10^{15} ohm cm.	D 257	Electrical Resistance of Insulating Materials
Surface Resistivity 100 % R.M.	3.6×10^6 megohms	D 257	
Stiffness, 73°F	50 000 to 90 000 psi	D 747	Stiffness of Plastics by Means of a Cantilever Beam.
Compressibility	16 to 22 %	D 1147	Compressibility and Recovery of Gasket Materials.
Hardness, Durometer D	50 to 65	D 676	Indentation of Rubber by Means of a Durometer.
Impact Strength, 70°F	2.0 ft. lbs/in. of notch	D 256	
73°F	3.0 ft. lbs/in. of notch		
170°F	6.0 ft. lbs/in. of notch		
Coefficient of Linear Thermal Expansion		D 696	Coefficient of Linear Thermal Expansion of Plastics.
77 to 148°F	6.20×10^{-5}		
77 to 58°F	7.50×10^{-5}		
77 to 32°F	11.10×10^{-5}		
77 to 212°F	6.90×10^{-5}		
77 to 482°F	9.70×10^{-5}		
77 to 572°F	12.10×10^{-5}		
Deformation Under Load		D 621	Deformation of Plastics Under Load.
73°F/1000 psi/24 h	2 to 3 %		
122°F/1200 psi/24 h	4 to 8 %		
Thermal Conductivity 0.18 in. thick specimen	1.7 BTU/hr/sq ft/°F/in.	Cenco-Fitch	
Water Absorption	0.01	D 570	Water Absorption of Plastics.
Flammability	Non-flammable	D 635	Test for Flammability of Rigid Plastics over 0.050 in. in Thickness
Chemical Resistance	Inert to almost all chemicals and solvents		

SUMMARY OF CHANGES

Committee D-20 has identified the location of selected changes to this specification since the last issue D3294 – 91a that may impact the use of this specification.

- D 3294 – 97:*
- (1) Deleted first line up to the first comma of 11.1. Changed 1 or 2, to 1, 2 or 3.
 - (2) Deleted and replaced the first sentence in 13.6.
 - (3) Deleted “in accordance with agreement between the purchaser and seller” from 14.1.

ASTM International takes no position respecting the validity of any patent rights asserted in connection with any item mentioned in this standard. Users of this standard are expressly advised that determination of the validity of any such patent rights, and the risk of infringement of such rights, are entirely their own responsibility.

This standard is subject to revision at any time by the responsible technical committee and must be reviewed every five years and if not revised, either reapproved or withdrawn. Your comments are invited either for revision of this standard or for additional standards and should be addressed to ASTM International Headquarters. Your comments will receive careful consideration at a meeting of the responsible technical committee, which you may attend. If you feel that your comments have not received a fair hearing you should make your views known to the ASTM Committee on Standards, at the address shown below.

This standard is copyrighted by ASTM International, 100 Barr Harbor Drive, PO Box C700, West Conshohocken, PA 19428-2959, United States. Individual reprints (single or multiple copies) of this standard may be obtained by contacting ASTM at the above address or at 610-832-9585 (phone), 610-832-9555 (fax), or service@astm.org (e-mail); or through the ASTM website (www.astm.org).