



Designation: D 3307 – 01

## Standard Specification for Perfluoroalkoxy (PFA)-Fluorocarbon Resin Molding and Extrusion Materials<sup>1</sup>

This standard is issued under the fixed designation D 3307; the number immediately following the designation indicates the year of original adoption or, in the case of revision, the year of last revision. A number in parentheses indicates the year of last reapproval. A superscript epsilon ( $\epsilon$ ) indicates an editorial change since the last revision or reapproval.

*This standard has been approved for use by agencies of the Department of Defense.*

### 1. Scope

1.1 This specification covers melt processable molding and extrusion materials of PFA-perfluoro(alkoxy alkane) fluorocarbon resin. The materials are copolymers of TFE-fluorocarbon resins containing perfluoroalkoxy side chains. These materials were formerly the subject of this specification and Specification D 6314.

1.2 This specification is intended to provide a means for calling out plastic materials used in the fabrication of end items or parts. It is not intended for the selection of materials. Material selection should be made by those having expertise in the plastics field after careful consideration of the design and the performance required of the part, the environment to which it will be exposed, the fabrication process to be employed, the costs involved, and the inherent properties of the material other than those covered by this specification.

1.3 This specification does not cover recycled plastics.<sup>2</sup>

1.4 The tests involved are intended to provide information for identifying the materials covered. It is not the function of this specification to provide engineering data for design purposes. Specimens prepared by injection molding or extrusion could yield test results that may vary from the values in this specification.

1.5 The values stated in SI units<sup>3</sup> are to be regarded as the standard. The values given in parentheses are for information only.

1.6 The following precautionary caveat pertains only to the test methods portions, Sections 8 and 9 of this specification: *This standard does not purport to address all of the safety concerns, if any, associated with its use. It is the responsibility of the user of this standard to establish appropriate safety and health practices and determine the applicability of regulatory limitations prior to use.*

<sup>1</sup> This specification is under the jurisdiction of ASTM Committee D20 on Plastics and is the direct responsibility of Subcommittee D20.15 on Thermoplastic Materials (Section D20.15.12).

Current edition approved December 10, 2001. Published February 2002. Originally published as D 3307 – 74. Last previous edition D 3307 – 00.

<sup>2</sup> As defined in Guide D 5033.

<sup>3</sup> As defined in IEEE/ASTM SI 10.

NOTE 1—This specification, ISO 12086–1(1995), and ISO 12086–2(1995) differ in approach or detail. Data obtained using either may not be technically equivalent.

### 2. Referenced Documents

#### 2.1 ASTM Standards:

D 150 Test Methods for A-C Loss Characteristics and Permittivity (Dielectric Constant) of Solid Electrical Insulating Materials<sup>4</sup>

D 618 Practice for Conditioning Plastics for Testing<sup>5</sup>

D 638 Test Method for Tensile Properties of Plastics<sup>5</sup>

D 792 Test Methods for Density and Specific Gravity (Relative Density) of Plastics by Displacement<sup>5</sup>

D 883 Terminology Relating to Plastics<sup>5</sup>

D 1238 Test Method for Melt Flow Rates of Thermoplastics by Extrusion Plastometer<sup>5</sup>

D 1600 Terminology for Abbreviated Terms Relating to Plastics<sup>5</sup>

D 2116 Specification for FEP-Fluorocarbon Molding and Extrusion Materials<sup>5</sup>

D 3892 Practice for Packaging/Packing of Plastics<sup>6</sup>

D 4591 Test Method for Determining Temperatures and Heats of Transitions of Fluoropolymers by Differential Scanning Calorimetry<sup>7</sup>

D 4895 Specification for Polytetrafluoroethylene (PTFE) Resins Produced from Dispersion<sup>7</sup>

D 5033 Guide for the Development of ASTM Standards Relating to Recycling and Use of Recycled Plastics<sup>7</sup>

D 6314 Specification for Fluorocarbon Perfluoromethoxy MFA Resin Molding and Extrusion Materials<sup>7</sup>

E 177 Practice for Use of the Terms Precision and Bias in ASTM Test Methods<sup>8</sup>

IEEE/ASTM SI 10 Standard for Use of the International System of Units (SI): The Modern Metric System<sup>8</sup>

#### 2.2 ISO Standards:

<sup>4</sup> Annual Book of ASTM Standards, Vol 10.01.

<sup>5</sup> Annual Book of ASTM Standards, Vol 08.01.

<sup>6</sup> Annual Book of ASTM Standards, Vol 08.02.

<sup>7</sup> Annual Book of ASTM Standards, Vol 08.03.

<sup>8</sup> Annual Book of ASTM Standards, Vol 14.02.



ISO 12086-1 Plastics-Fluoropolymer Dispersions and Moulding and Extrusion Materials-Part 1<sup>9</sup>  
 ISO 12086-2 Plastics-Fluoropolymer Dispersions and Moulding and Extrusion Materials-Part 2<sup>9</sup>

### 3. Terminology

3.1 *Definitions*—Definitions are in accordance with Terminology D 883.

3.1.1 *lot, n*—one production run or a uniform blend of two or more productions runs.

### 4. Classification

4.1 This specification covers eight types of PFA-fluorocarbon resins supplied in pellet form for molding and extrusion.

4.2 A one-line system may be used to specify materials covered by this specification. The system uses predefined cells to refer to specific aspects of this specification, illustrated as follows:

Specification							
Standard Number Block	:	Type	:	Grade	:	Class	Special Notes
_____	:	_____	:	_____	:	_____	_____

Example: Specification D 3307 – 01, \_\_\_\_\_

In this standard, the only specifications are type; no grade or class is required. A comma is used as the separator between the standard number and the type.<sup>10</sup>

### 5. General Requirements

5.1 The materials shall be of uniform composition and so prepared as to conform to the requirements of this specification.

5.2 The materials described in this specification shall be free of foreign matter to such a contamination level as may be required in 10.4.

### 6. Detail Requirements

6.1 The materials covered by this specification shall conform to the requirements prescribed in Table 1 and Table 2 when tested by the procedures specified herein. Table 2 lists those tests requiring a specimen molded as described in 9.1.

<sup>9</sup> Available from the American National Standards Institute, 25 W. 43rd St., 4th Floor, New York, NY 10036.

<sup>10</sup> See *ASTM Form and Style Manual*.

### 7. Sampling

7.1 Sampling shall be statistically adequate to satisfy the requirements of 10.4.

### 8. Number of Tests

8.1 One set of test specimens as prescribed in Section 9 shall be considered sufficient for testing each sample. The average result of the specimens tested shall conform to the requirements of this specification.

### 9. Test Methods

#### 9.1 Test Specimens:

9.1.1 Prepare a molded sheet  $1.50 \pm 0.25$ -mm ( $0.060 \pm 0.010$ -in.) thick. Use a picture-frame-type chase having a suitable blanked-out section and thickness to produce the desired sheet. Use clean aluminum foil, 0.13 to 0.18 mm (0.005 to 0.007 in.) thick, in contact with the resin. A high temperature mold release agent may be sprayed on the aluminum foil to help prevent the foil from sticking to the sheet. Use steel molding plates at least 1.0 mm (0.040 in.) thick and of an area adequate to cover the chase.

9.1.2 Lay down and smoothly cover one plate with a sheet of aluminum foil. Place the mold chase on top of this assembly. Place within the mold chase sufficient molding material to produce the required sheet in such manner that the polymer charge is a mound in the middle of the chase. Place a second sheet of aluminum foil on top of the granules and add the top mold plate. Place the assembly in a compression molding press having platens that have been heated to  $380 \pm 5^\circ\text{C}$  ( $716 \pm 10^\circ\text{F}$ ).

9.1.3 Bring the press platens to incipient contact with the mold assembly. Hold for 2 to 4 min without pressure. Apply approximately 1 MPa (145 psi) and hold for 1 to 1.5 min. Then apply 2 to 4 MPa (290 to 580 psi) and hold for 1 to 1.5 min. Maintain the press at  $380 \pm 5^\circ\text{C}$  ( $716 \pm 10^\circ\text{F}$ ) during these steps. Remove the assembly from the press and place between two  $20 \pm 7$ -mm ( $0.75 \pm 0.25$ -in.) steel plates whose temperature is less than  $40^\circ\text{C}$  ( $104^\circ\text{F}$ ).

9.1.4 When the sheet is cool enough to touch (about 50 to  $60^\circ\text{C}$  ( $122$  to  $140^\circ\text{F}$ )), remove the aluminum foil from the sheet. (If the sheet is allowed to cool to room temperature, the aluminum foil cannot be pulled free.)

#### 9.2 Conditioning:

9.2.1 For tests of specific gravity, tensile properties, and electrical properties, condition the molded test specimens in accordance with Procedure A of Practice D 618 for a period of at least 4 h prior to test. The other tests require no conditioning.

**TABLE 1 Detail Requirements for Test on Molding and Extrusion Materials**

	Type I	Type II	Type III	Type IV	Type V	Type VI	Type VII	Type VIII
Melt flow, <sup>A</sup> g/10min:								
min	>7	1	>3	>10	1	>3	10	2
max	18	3	7	30	3	10	17	5
Melting endotherm peak temperature, <sup>B</sup> min, °C	300	300	300	285	285	285	280	280

<sup>A</sup>See 9.3 of this specification.

<sup>B</sup>See 9.4 of this specification.



**TABLE 2 Detailed Requirements for Molded Specimens**

	Type I	Type II	Type III	Type IV	Type V	Type VI	Type VII	Type VIII
Specific gravity, 23°C (73.4°F): <sup>A</sup>								
min	2.12	2.12	2.12	2.12	2.12	2.12	2.12	2.12
max	2.17	2.17	2.17	2.17	2.17	2.17	2.17	2.17
Tensile strength, min, 23°C (73.4°F): <sup>B</sup>								
MPa	20.68	25	20.68	22.75	25.51	22.75	20.68	26.20
psi	3000	3625	3000	3300	3700	3300	3000	3800
Elongation, 23°C (73.4°F), min, %: <sup>B</sup>	275	300	275	275	260	275	275	300
Dielectric constant, max: <sup>C</sup>								
10 <sup>2</sup> Hz	2.2	2.2	2.2	2.2	2.2	2.2	2.2	2.2
10 <sup>6</sup> Hz	2.2	2.2	2.2	2.2	2.2	2.2	2.2	2.2
Dissipation factor, max: <sup>C</sup>								
10 <sup>2</sup>	0.0003	0.0003	0.0003	0.0003	0.0003	0.0003	0.0003	0.0003
10 <sup>6</sup>	0.0005	0.0005	0.0005	0.0005	0.0005	0.0005	0.0003	0.0005

<sup>A</sup>See 9.5 of this specification.

<sup>B</sup>See 9.6 of this specification.

<sup>C</sup>See 9.7 of this specification.

9.2.2 Conduct tests at the Standard Laboratory Temperature of 23 ± 2°C (73.4 ± 3.6°F) for determination of specific gravity, tensile properties, and electrical properties only. Since the resin does not absorb water, the maintenance of constant humidity during testing is not necessary. Conduct tests for melt flow rate and melting endotherm under ordinary laboratory conditions.

9.3 *Melt Flow Rate*—Determine the melt flow rate in accordance with Test Method D 1238, Test Method A or B, with a temperature of 372 ± 1°C and using a total load, including piston, of 5000 g. The same requirements apply for the use of corrosion-resistant alloy for the barrel lining, orifice, and piston tip.

9.4 *Melting Endotherm Peak Temperature:*

9.4.1 Determine the melting endotherm peak temperature using techniques in Test Method D 4591 and Specification D 4895. Place a 20-mg specimen in a 4-mm tube with a thermocouple. Premelt the specimen at 325°C, and push the thermocouple into intimate contact with the melt. Cool the sample in air. Run the differential thermal analysis at 10°C/min with glass beads as a reference to a maximum temperature of 350°C. Extend straight lines down tangent to both sides of the melting endotherm, and take the temperature at which the lines intersect (peak minimum) as the melting endotherm peak temperature.

9.4.2 *Precision*—The single instrument precision of the differential thermal analysis applied to this material is ±1.2°C (2S) as defined in Practice E 177.

9.5 *Specific Gravity*—Cut two specimens from the compression molded sheet and test in accordance with Test Method D 792.

9.6 *Tensile Properties*—Cut five specimens with the micro-tensile die shown in Fig. 1, which is exactly the same as Fig. 1 of Test Method D 1708. The die shall be of the steel-rule type of curvature of 5 ± 0.5-mm (0.20 ± 0.02-in.) type. Determine the tensile properties in accordance with the procedures described in Test Method D 638, except that the specimens used shall be as detailed above, the initial jaw separation shall be 22 ± 0.13 mm (0.866 ± 0.005 in.), and the speed of testing shall

be 50 mm/min (2 in./min). Clamp the specimens with essentially equal lengths in each jaw. Determine the elongation from the chart, expressing it as a percentage of the initial jaw separation. Details appear in the Tensile Properties section of Specification D 2116.

9.7 *Dielectric Constant and Dissipation Factor*—Determine dielectric constant and dissipation factor on three specimens, each 101.6 mm (4 in.) in diameter in accordance with Test Methods D 150. Testing shall be at 10<sup>2</sup> Hz and 10<sup>6</sup> Hz.

**10. Inspection and Certification**

10.1 Inspection and certification of the material supplied with reference to a specification based on this classification system shall be for conformance to the requirements specified herein.

10.2 Lot-acceptance shall be the basis on which acceptance or rejection of the lot is made. The lot acceptance inspection shall consist of melting endotherm peak temperature and melt flow rate.

10.3 Periodic check inspection with reference to a specification based on this classification system shall consist of the test for all requirements of the material in accordance with this specification.

10.4 Certification shall be that the material was manufactured by a process in statistical control, sampled, tested, and inspected in accordance with this classification system, and that the average values for the lot meet the requirements of this specification.

10.5 A report of test results shall be furnished when requested. The report shall consist of results of the lot-acceptance inspection for the shipment and the results of the most recent periodic-check inspection.

**11. Packaging and Package Marking**

11.1 All packing, packaging, and marking provisions of Practice D 3892 shall apply to this specification.

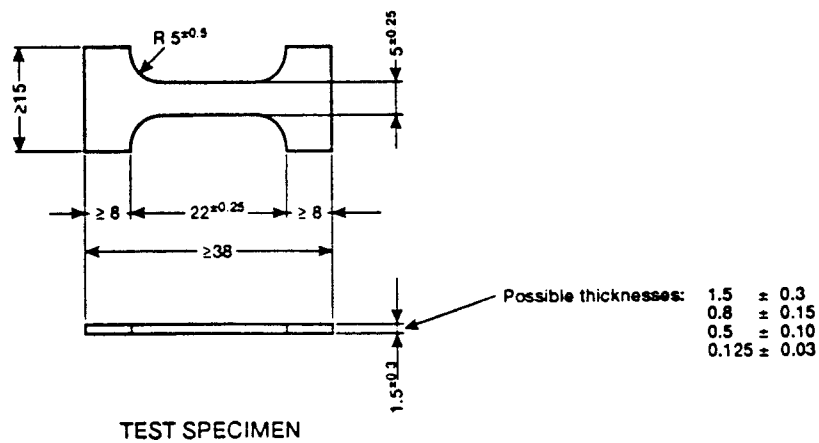
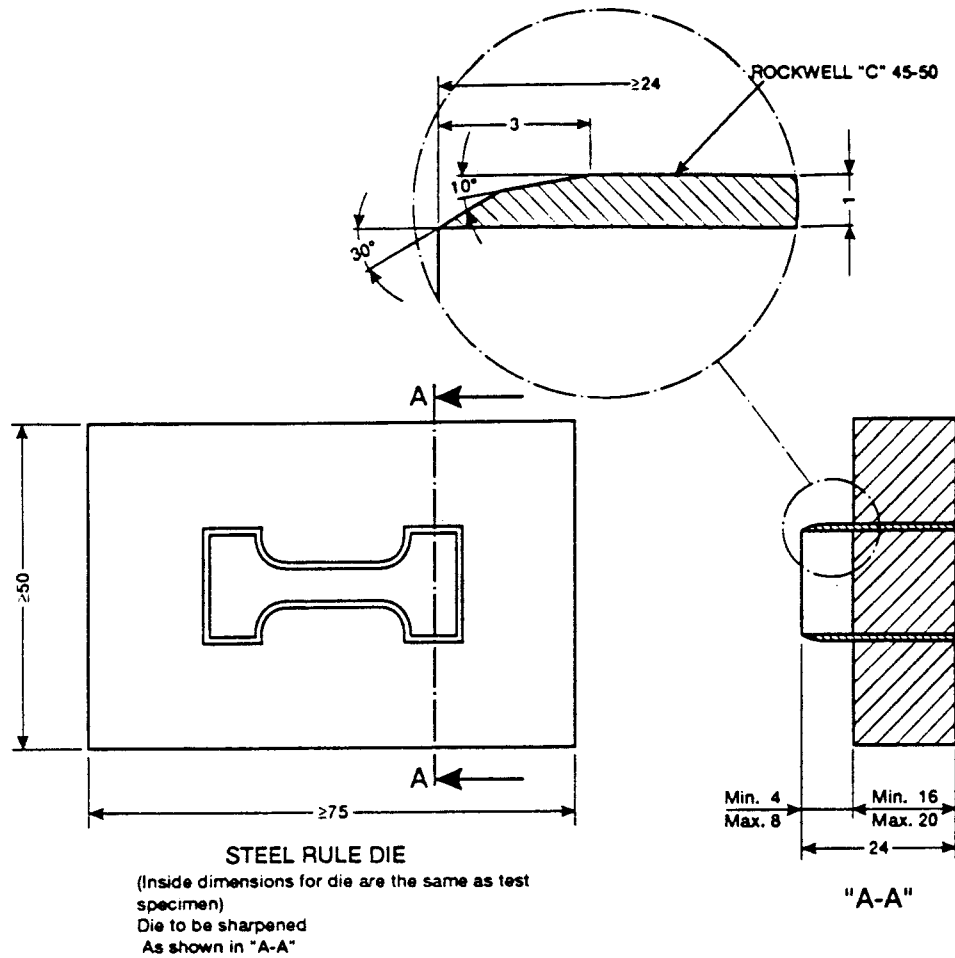

NOTE 1—All dimensions are in millimetres.  
**FIG. 1** Microtensile Die and Test Specimen

## 12. Keywords

12.1 extrusion; injection molding; fluoropolymer, perfluoroalkoxy; PFA-fluorocarbon resin; tetrafluoroethylene copolymer; TFE-fluorocarbon



## SUMMARY OF CHANGES

This section identifies the location of selected changes to this specification. For the convenience of the user, Committee D20 has highlighted those changes that may impact the use of this specification. This section may also include descriptions of the changes or reasons for the changes, or both.

### *D 3307–98:*

- (1) Added perfluoro(alkoxy alkane) to Section 1 and to the title.
- (2) Inserted in 1.4: This section does not cover recycled plastics.
- (3) Inserted Note 1 to include ISO equivalency statement.
- (4) Renumbered Section 1 and added Footnotes 2 and 3.
- (5) Inserted in 2.1: Test Methods D 1238, D 1708, and D 4591; Guide D 5033; IEEE/ASTM SI 10; and ISO 12086–1 and 2.
- (6) In 2.1, updated footnote information.
- (7) In 4.2, upgraded callout section to reflect this specification.
- (8) In 9.3, added reference to Test Method D 1238 and eliminated reference to Specification D 2116.
- (9) In 9.4, added reference to Test Method D 4591.
- (10) In 9.6, upgraded dimensions to reflect ISO tensile strength die and replaced Fig. 1 with ISO equivalent.
- (11) In 12.1, at the end of first sentence added reference to Table 3.
- (12) In 7.1, removed incorrect wording.
- (13) In 9.1, added qualification statement.
- (14) Added Section 12, Keywords.
- (15) Added Summary of Changes.
- (16) In Section 2, changed Tensile Strength, Type II, from 3800 psi to 3625 psi and changed 26.20 MPa to 25.0 MPa.

### *D 3307 – 00:*

- (1) Added Terminologies D 883 and D 1600 to Section 2.
- (2) Deleted Test Method D 1708, Practice D 1898, and Specification D 2116 from Section 2.
- (3) Added Section 3 on Terminology, including a definition for *lot*.
- (4) Renumbered all following sections accordingly.
- (5) Deleted 6.1 and replaced with upgraded sampling process (now 7.1).
- (6) Added three additional types to Table 1.
- (7) Added three additional types to Table 2.
- (8) Changed Section 9, Retest and Rejection, to Section 10, Inspection and Certification, with appropriate subheadings.
- (9) Added footnotes to Tables 1 and 2 referencing sections within this specification.

### *D 3307 – 01:*

- (1) The materials from Specification D 6314 (Type VII and Type VIII) were added since they are all PFA materials.
- (2) The scope was changed to reflect the need for proper selection of any of these materials based on performance desired and properties.
- (3) Precision and Bias section has been removed.

*ASTM International takes no position respecting the validity of any patent rights asserted in connection with any item mentioned in this standard. Users of this standard are expressly advised that determination of the validity of any such patent rights, and the risk of infringement of such rights, are entirely their own responsibility.*

*This standard is subject to revision at any time by the responsible technical committee and must be reviewed every five years and if not revised, either reapproved or withdrawn. Your comments are invited either for revision of this standard or for additional standards and should be addressed to ASTM International Headquarters. Your comments will receive careful consideration at a meeting of the responsible technical committee, which you may attend. If you feel that your comments have not received a fair hearing you should make your views known to the ASTM Committee on Standards, at the address shown below.*

*This standard is copyrighted by ASTM International, 100 Barr Harbor Drive, PO Box C700, West Conshohocken, PA 19428-2959, United States. Individual reprints (single or multiple copies) of this standard may be obtained by contacting ASTM at the above address or at 610-832-9585 (phone), 610-832-9555 (fax), or service@astm.org (e-mail); or through the ASTM website (www.astm.org).*