



# Standard Practice for Plastics: Dynamic Mechanical Properties: Determination and Report of Procedures<sup>1</sup>

This standard is issued under the fixed designation D 4065; the number immediately following the designation indicates the year of original adoption or, in the case of revision, the year of last revision. A number in parentheses indicates the year of last reapproval. A superscript epsilon ( $\epsilon$ ) indicates an editorial change since the last revision or reapproval.

*This standard has been approved for use by agencies of the Department of Defense.*

## 1. Scope\*

1.1 This practice is for general use in gathering and reporting dynamic mechanical data. It incorporates laboratory practice for determining dynamic mechanical properties of specimens subjected to various oscillatory deformations on a variety of instruments of the type commonly called dynamic mechanical analyzers or dynamic thermomechanical analyzers.

1.2 This practice is intended to provide means of determining the transition temperatures, elastic, and loss moduli of plastics over a range of temperatures, frequencies, or time, by free vibration and resonant or nonresonant forced vibration techniques. Plots of elastic and loss moduli are indicative of the viscoelastic characteristics of a plastic. These moduli are functions of temperature or frequency in plastics, and change rapidly at particular temperatures or frequencies. The regions of rapid moduli change are normally referred to as transition regions.

1.3 The practice is primarily useful when conducted over a range of temperatures from  $-160^{\circ}\text{C}$  to polymer degradation and is valid for frequencies from 0.01 to 1000 Hz.

1.4 This practice is intended for materials that have an elastic modulus in the range from 0.5 MPa to 100 GPa (73 psi to  $1.5 \times 10^7$  psi).

1.5 Apparent discrepancies may arise in results obtained under differing experimental conditions. Without changing the observed data, reporting in full (as described in this practice) the conditions under which the data were obtained will enable apparent differences observed in another study to be reconciled.

1.6 Test data obtained by this practice are relevant and appropriate for use in engineering design.

1.7 The values stated in SI units are to be regarded as the standard. The values given in parentheses are for information only.

1.8 *This standard does not purport to address all of the safety concerns, if any, associated with its use. It is the*

*responsibility of the user of this practice to establish appropriate safety and health practices and determine the applicability of regulatory limitations prior to use. Specific hazards statements are given in Section 8.*

NOTE 1—This practice is technically equivalent to ISO 6721, Part 1.

## 2. Referenced Documents

### 2.1 ASTM Standards:

D 618 Practice for Conditioning Plastics and Electrical Insulating Materials for Testing<sup>2</sup>

D 4000 Classification System for Specifying Plastic Materials<sup>3</sup>

D 4092 Terminology Relating to Dynamic Mechanical Measurements on Plastics<sup>3</sup>

### 2.2 ISO Standard:

ISO 6721, Part 1 Plastics— Determination of Dynamic Mechanical Properties, Part 1, General Principles<sup>4</sup>

## 3. Terminology

3.1 *Definitions*—For definitions of terms relating to this practice, see Terminology D 4092.

## 4. Summary of Practice

4.1 A specimen of known geometry is placed in mechanical oscillation either at fixed or natural resonant frequencies. Elastic or loss moduli, or both of the specimen are measured while varying time, temperature of the specimen or frequency, or both, of the oscillation. Plots of the elastic or loss moduli, or both, are indicative of viscoelastic characteristics of the specimen. Rapid changes in viscoelastic properties at particular temperatures, times, or frequency are normally referred to as transition regions.

NOTE 2—The particular method for measurement of elastic and loss moduli depends upon the operating principle of the instrument used.

<sup>1</sup> This practice is under the jurisdiction of ASTM Committee D20 on Plastics and is the direct responsibility of Subcommittee D20.10 on Mechanical Properties.

Current edition approved September 10, 2001. Published November 2001. Originally published as D 4065 – 82. Last previous edition D 4065 – 95.

<sup>2</sup> *Annual Book of ASTM Standards*, Vol 08.01.

<sup>3</sup> *Annual Book of ASTM Standards*, Vol 08.02.

<sup>4</sup> Available from American National Standards Institute, 25 W. 43rd St., New York, NY 10036.

\*A Summary of Changes section appears at the end of this standard.

## 5. Significance and Use

5.1 Dynamic mechanical testing provides a method for determining elastic and loss moduli as a function of temperature, frequency or time, or both. A plot of the elastic modulus and loss modulus of material versus temperature provides a graphical representation of elasticity and damping as a function of temperature or frequency.

5.2 This procedure can be used to locate transition temperatures of plastics, that is, changes in the molecular motions of a polymer. In the temperature ranges where significant changes occur, elastic modulus decreases rapidly with increasing temperature (at constant or near constant frequency) or increases with increasing frequency (at constant temperature). A maximum is observed for the loss modulus.

5.3 This procedure can be used, for example, to evaluate by comparison to known reference materials:

5.3.1 Degree of phase separation in multicomponent systems,

5.3.2 Filler type, amount, pretreatment, and dispersion, and

5.3.3 Effects of certain processing treatment.

5.4 This procedure can be used to determine the following:

5.4.1 Stiffness of polymer composites, especially as a function of temperature,

5.4.2 Degree of polymer crystallinity, and

5.4.3 Magnitude of triaxial stress state in the rubber phase of rubber modified polymers.

5.4.4 This procedure is useful for quality control, specification acceptance, and research.

5.5 For many materials, there may be a specification that requires the use of this practice, but with some procedural modifications that take precedence when adhering to the specification. Therefore, it is advisable to refer to that material specification before using this practice. Table 1 of Classification System D 4000 lists the ASTM materials standards that currently exist.

## 6. Interferences

6.1 Since small quantities of specimen are used, it is essential that the specimens be homogeneous or representative, or both.

## 7. Apparatus

7.1 The function of the apparatus is to hold a plastic specimen of uniform cross section, so that the specimen acts as the elastic and dissipative element in a mechanically oscillated system. Instruments of this type are commonly called dynamic mechanical or dynamic thermomechanical analyzers. They typically operate in one of seven oscillatory modes: (1) freely decaying torsional oscillation, (2) forced constant amplitude, resonant, flexural oscillation, (3) forced constant amplitude, fixed frequency, compressive oscillation, (4) forced constant amplitude, fixed frequency, flexural oscillation, (5) forced, constant amplitude, fixed frequency, tensile oscillation, (6) forced constant amplitude, fixed frequency, torsional oscillation and (7) forced constant amplitude, fixed frequency, or variable frequency dual cantilever.

7.2 The apparatus shall consist of the following:

7.2.1 *Clamps*—A clamping arrangement that permits gripping of the sample.

7.2.2 *Oscillatory Deformation (Strain)*—A device for applying an oscillatory deformation (strain) to the specimen. The deformation (strain) may be applied and then released, as in free-vibration devices, or continuously applied, as in forced-vibration devices (see Table 1).

7.2.3 *Detectors*—A device or devices for determining dependent and independent experimental parameters, such as force (stress or strain), frequency, and temperature. Temperature should be measurable with an accuracy of  $\pm 1^\circ\text{C}$ , frequency to  $\pm 1\%$ , and force to  $\pm 1\%$ .

7.2.4 *Temperature Controller and Oven*—A device for controlling the specimen temperature, either by heating (in steps or ramps), cooling (in steps or ramps), or maintaining a constant specimen environment. Any temperature programmer should be sufficiently stable to permit measurement of sample temperature to  $\pm 0.5^\circ\text{C}$ .

7.3 Nitrogen or other gas supply for purging purposes.

7.4 Calipers or other length-measuring device capable of measuring to an accuracy of 0.01 mm.

## 8. Hazards

8.1 *Precautions:*

8.1.1 Toxic or corrosive effluents, or both, may be released when heating the specimen near its decomposition point and can be harmful to personnel or to the apparatus.

8.1.2 Take care to prevent buckling of the clamped specimen due to thermal expansion during the test.

## 9. Test Specimens

9.1 Specimens may be any uniform size or shape but are ordinarily analyzed in rectangular form. If some heat treatment is applied to the specimen to obtain this preferred analytical form, this treatment should be noted in the report.

9.2 Due to the numerous types of dynamic mechanical instruments, specimen size is not fixed by this practice. In many cases, a specimen of 0.75 by 9.4 by 50 mm (0.03 by 0.38 by 2.0 in.) is found to be usable and convenient.

NOTE 3—It is important to select a specimen size consistent with the modulus of the material under test and capabilities of the measuring apparatus. For example, thick specimens of low modulus materials may be suitable for measurement, while thin specimens of high modulus materials may be required.

9.3 Condition the specimen at  $23 \pm 2^\circ\text{C}$  ( $73 \pm 4^\circ\text{F}$ ) and  $50 \pm 5\%$  relative humidity for not less than 40 h prior to test in accordance to Procedure A of Practice D 618, for those tests where conditioning is required. If other specimen conditioning is used, it should be noted in the report.

## 10. Calibration

10.1 Using the same heating rate or schedule to be used for specimens, calibrate the instrument temperature axis, using the instrument manufacturer's procedures with either or both of the following substances.

Standard	Transition Temperature, $^\circ\text{C}$	Type of Transition
Water	0.0	fusion
Indium	156.6	fusion

10.2 Calibrate the instrument using procedures recommended by the manufacturer.

11. Procedure

11.1 Measure the length, width, and thickness of the specimen to an accuracy of ±1 %.

11.2 Maximum strain amplitude should be within the linear viscoelastic range of the material. Strains of less than 1 % are recommended.

11.3 If temperature is to be the independent variable:

11.3.1 The test frequency may be from 0.01 to 500 Hz, fixed or changing as the dependent variable.

TABLE 1 Summary of Techniques and Calculations Used to Determine Dynamic Mechanical Properties

Technique	Input Excitation	Mode of Oscillation	Frequency Range, Hz	Specimen Size, mm	Calculations		
					Oscillating Strain	Elastic Component	Damping Component
Dynamic mechanical analyzer	Sinusoidal/ fixed or resonance frequency	Forced constant amplitude-fixed or resonance frequency flexural oscillation	0.001 to 60 Hz	$t = 0.01-1.6$ $b = 0.02-13$ $L = 18, 25, \text{ or } 33$	$\pm 3tA(2D + L)/L^2R$	Rectangular: $E' = \frac{4\pi^2 f^2 I-H}{2b(L/2 + D)^2} [L/t]^3$  Circular: $E' = 4\pi^2 f^2 I-H/3r^4 (2D + L)^2 [2L^3]$	$\text{Tan } \delta = JV/f^2$
Visco-elastometer <sup>A</sup>	Sinusoidal fixed frequency	Forced constant amplitude-fixed frequency-tensile oscillation (see Fig. 4)	3.5, 11, 35, 110	$L = 7 \text{ cm}$ $T = 0.05 \text{ cm}$ $B = 0.4 \text{ cm}$	$\Delta L/L$	Rectangular cross section: $E' = NL/bt\Delta L \cos \delta$	$E'' = NL/tb\Delta L \sin \delta$ Tan $\delta$ directly read
					$\Delta L/L$	Circular cross section: $E' = NL \cos \delta / \pi r^2 \Delta L$	$E'' = NL \sin \delta / \pi r^2 \Delta L$ Tan $\delta$ directly read
Mechanical spectrometer <sup>B,C</sup>	Sinusoidal fixed or variable frequency	Forced constant amplitude; fixed or variable frequency-tensile oscillation (see Fig. 5)	0.0016 to 80	$t = 0.025-1.0$ $b = 12.7$ $L = 63.5$	$\Delta L/L$	Rectangular cross section: $E' = NL \cos \delta / bt \Delta L$	$E'' = NL \sin \delta / tb\Delta L$ Tan $\delta$ directly read
				$r = 1.6, 2.35, 3.15$ $L = 63.5$	$\Delta L/L$	Circular cross section: $E' = NL \cos \delta / \pi r^2 \Delta L$	$E'' = NL \sin \delta / \pi r^2 \Delta L$ Tan $\delta$ directly read
Mechanical spectrometer <sup>B,C</sup>	Sinusoidal fixed or variable frequency	Forced constant amplitude; fixed or variable frequency-compressive oscillation (see Fig. 6)	0.0016-80	$t = 38$ $b = 38$ $L = 1-10$ $r = 8-50$ $t = 1-10$	$\Delta L/L$	Rectangular cross section: $E' = NL \cos \delta / tb \Delta L$	$E'' = NL \sin \delta / tb\Delta L$ Tan $\delta$ directly read
				$t = 1-10$	$\Delta L/L$	Circular cross section: $E' = NL \cos \delta / \pi r^2 \Delta L$	$E'' = NL \cos \delta / \pi r^2 \Delta L$ Tan $\delta$ directly read
Mechanical spectrometer <sup>B,C</sup>	Sinusoidal fixed or variable frequency	Forced constant amplitude; fixed or variable frequency-flexural oscillation (see Fig. 7)	0.0016-80	$t = 0.5-6.4$ $b = 12.7$ $L = 63.5$	$3 ta/L^2$	Rectangular cross section:	

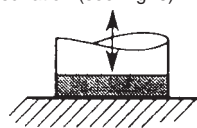
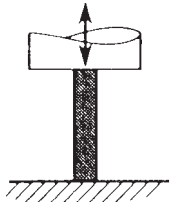
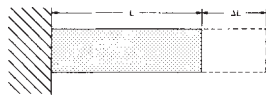
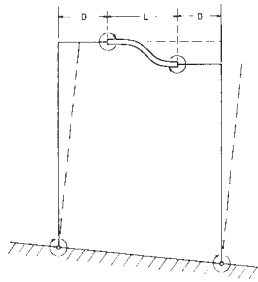

TABLE 1 Continued

Technique	Input Excitation	Mode of Oscillation	Frequency Range, Hz	Specimen Size, mm	Calculations		
					Oscillating Strain	Elastic Component	Damping Component
						$E' = NL^3 \cos \delta / 2bt^3a$	$E'' = NL^3 \sin \delta / 2bt^3a$ Tan $\delta$ directly read
				$r = 0.25-3.2$ $L = 63.5$	$3 ra/L^2$	Circular cross section: $E' = 4NL^3 \cos \delta / 3r^4a$	$E'' = 4NL^3 \sin \delta / 3r^4a$ Tan $\delta$ directly read
Dynamic Mechanical Analyzer <sup>B,D</sup>	Sinusoidal fixed or variable frequency	Constant force amplitude; fixed or variable frequency-tensile oscillation (see Fig. 5)	0.01-50	$t = \text{up to } 2.0$ $b = \text{up to } 10$ $L = \text{up to } 24$	$\Delta L/L$	Rectangular cross section: $E' = NL \cos \delta / bt \Delta L$	$E'' = NL \sin \delta / tb \Delta L$ Tan $\delta$ directly read
				$r = \text{up to } 2.0$ $L = \text{up to } 24$	$\Delta L/L$	Circular cross section: $E' = NL \cos \delta / \pi r^2 \Delta L$	$E'' = NL \sin \delta / \pi r^2 \Delta L$ Tan $\delta$ directly read
Dynamic Mechanical Analyzer <sup>B,D</sup>	Sinusoidal fixed or variable frequency	Constant force amplitude; fixed or variable frequency-compression oscillation (see Fig. 6)	0.01-50	Up to $3 \times 20$ $t = \text{up to } 20$ $b = \text{up to } 20$ $L = 0.001-24$ $r = 1-20$ $t = \text{up to } 20$	$\Delta L/L$	Rectangular cross section: $E' = NL \cos \delta / tb \Delta L$	$E'' = NL \sin \delta / tb \Delta L$ Tan $\delta$ directly read
					$\Delta L/L$	Circular cross section: $E' = NL \cos \delta / \pi r^2 \Delta L$	$E'' = NL \sin \delta / \pi r^2 \Delta L$ Tan $\delta$ directly read
Dynamic Mechanical Analyzer <sup>B,D</sup>	Sinusoidal fixed or variable frequency	Constant force amplitude; fixed or variable frequency-flexural oscillation (see Fig. 7)	0.01-50	$t = \text{up to } 24$ $b = \text{up to } 10$ $L = \text{up to } 20$	$3 ta/L^2$	Rectangular cross section: $E' = NL^3 \cos \delta / 2bt^3a$	$E'' = NL^3 \sin \delta / 2bt^3a$ Tan $\delta$ directly read
				$r = \text{up to } 5$ $L = \text{up to } 20$	$3 ra/L^2$	Circular cross section: $E' = 4NL^3 \cos \delta / 3r^4a$	$E'' = 4NL^3 \sin \delta / 3r^4a$ Tan $\delta$ directly read
Mechanical spectrometer <sup>B,C</sup>	Sinusoidal fixed or variable frequency	Forced constant amplitude; fixed or variable frequency-torsional oscillation (see Fig. 8)	0.0016-80	0.5 to 6.4t 12.7b 63.5L	Rectangular cross section: $K\theta$ $(3a + 1.8b) / 8b^2L t^2$	Rectangular cross section: $G' = \frac{TL \cos \delta}{K\theta}$ where:	$G'' = TL \sin \delta / \theta K$

TABLE 1 Continued

Technique	Input Excitation	Mode of Oscillation	Frequency Range, Hz	Specimen Size, mm	Calculations		
					Oscillating Strain	Elastic Component	Damping Component
						$K = bt^3 \left[ 16/3 - 3.36 \frac{t}{b} (1 - t^4/12b^4) \right]$	
				3.2, 4.7, 6.4 dia, 63.5L	Circular cross section: $t\theta/L$	Circular cross section: $G' = 2TL \cos \delta / \pi r^4 \theta$	Tan $\delta$ directly read
Mechanical spectrometer <sup>B,C</sup>	Sinusoidal fixed frequency	Forced constant amplitude fixed frequency flexural oscillation (single or dual cantilever)	.01–200	$L = 1-46$ $t = .1-5$ $b = .1-18$	$3 ta/L^2$	$E' = \frac{S'10^D}{2b(tL)^3}$	Tan $\delta$ directly read
							
Mechanical spectrometer <sup>B,C</sup>	Sinusoidal fixed frequency	Forced constant amplitude fixed frequency shear oscillation	.01–200	$t = .1-3$	$a/t$	$G' = \frac{S'10^D t}{2A}$	Tan $d$ directly read
							
Mechanical spectrometer <sup>B,C</sup>	Sinusoidal fixed frequency	Forced constant amplitude fixed frequency tensile oscillation	.01–100	$t = .005-1$ $b = .01-18$ $L = 1-20$	$a/L$	$E' = \frac{S'10^D L}{wt}$	Tan $d$ directly read
							
Mechanical spectrometer <sup>B,C</sup>	Sinusoidal, fixed or variable frequency	Forced constant amplitude fixed or variable frequency in dual cantilever geometry	0.00016–16.0	$t = \text{up to } 1.59$ $b = \text{up to } 6.4$ $L = \text{up to } 44.5$	$12 tA/L$	$E' = (NL^3/Bt^3A)\cos\delta$	$E' = (NL^3/Bt^3A)\sin\delta$
							

<sup>A</sup> Instruments of this type are available from IMASS, Inc., Box 134, Accord, MA 02018.

<sup>B</sup> Instruments of this type are available from TA Instruments, 109 Lukens Drive, New Castle, DE 19720.

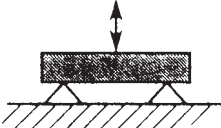
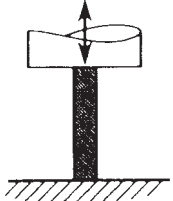
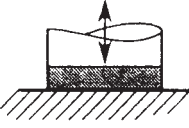
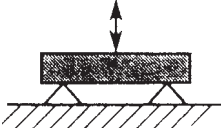
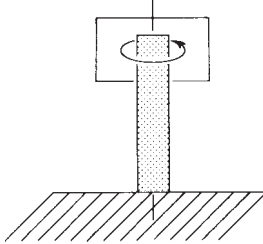
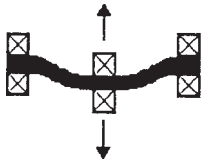
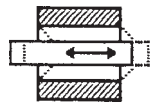
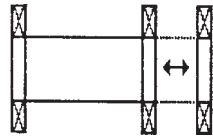
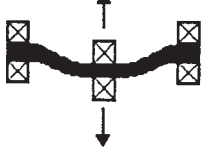
<sup>C</sup> Instruments of this type are available from Rheometric-Scientific, Inc., One Possumtown Road, Piscataway, NJ 08854.

<sup>D</sup> Instruments of this type are available from The Perkin-Elmer Corp., 761 Main Avenue, Norwalk, CT 06859-0256.

Symbols:

$I$  = moment of inertia of the inertial member  
 $f$  = frequency of oscillation  
 $L$  = specimen length between clamp  
 $b$  = specimen width

$D$  = clamping distance  
 $H$  = instrument constant  
 $J$  = instrument constant  
 $V$  = instrument provided dependent variable

$t$  = specimen thickness  
 $r$  = specimen radius

$G'$  = elastic modulus in shear  
 $\Delta$  = logarithmic decrement  
 $G''$  = loss modulus in shear  
 $\Delta L$  = change in length  
 $E'$  = elastic modulus  
 $E''$  = loss modulus

$A$  = oscillation amplitude  
 $\theta$  = angular displacement  
 $k$  = constant  
 $a$  = parallel axes displacement

$T$  = torque,  
 $RR$  = relative rigidity  
 $n$  = number of cycles for oscillation to decay a specific amount  
 $P$  = period of oscillation  
 $\delta$  = phase angle  
 $N$  = axial force  
 $Z$  = elapsed time  
 $R$  = instrument arm length

11.3.2 Vary the temperature of the test specimen from the lowest to the highest temperature of interest while measuring its elastic and viscous properties.

NOTE 4—Preferably, tests conducted over a temperature range should be performed in incremental steps or at a rate slow enough to allow temperature equilibrium throughout the entire specimen. The time to reach equilibrium will depend upon the mass of the particular specimen and the gripping arrangement. Temperature program rates of 1 to 2°C/min or 2 to 5°C step intervals held for 3 to 5 min have been found suitable. The effect of heating rate may be observed by running specimens at two or more rates and comparing the elastic and viscous property results obtained.

NOTE 5—The accuracy required of the temperature measurement will depend upon the rate of change of moduli with temperature of the plastic being investigated. In transition regions, experience has indicated that the specimen temperature should be read to  $\pm 0.5^\circ\text{C}$ .

11.3.3 Duplicate specimens should be examined, and the mean results reported.

11.4 If frequency is to be the independent variable:

11.4.1 The test temperature should be fixed at the desired value.

11.4.2 Vary the frequency applied to the test specimen while measuring its elastic and viscous properties.

11.4.3 Duplicate specimens should be examined and the mean results reported.

## 12. Calculation

12.1 Calculate the dynamic mechanical properties using the equations given in Table 1 or in the manufacturer's operating manual.

12.1.1 Use the average measured values of specimen length, width, and thickness.

## 13. Report

13.1 Report the following information:

13.1.1 Complete identification and description of the material tested including name, stock or code number, date made, form, source, etc.

13.1.2 Description of the instrument used for test.

13.1.3 Dimensions of the test specimen.

13.1.4 Description of the calibration procedure.

13.1.5 Identification of the sample atmosphere by gas composition, purity, and rate used.

13.1.6 Details of conditioning the specimen prior to test.

13.1.7 The temperature program including initial and final temperatures as well as rate of linear temperature change or size and duration of temperature steps.

13.1.8 Table of data and results.

13.1.9 Number of specimens tested.

13.1.10 A plot of the elastic moduli and loss moduli versus temperature (or frequency) where tests are conducted at more than one temperature (or frequency).

13.1.10.1 Moduli should be plotted on the ordinate with upward deflections as increase in elasticity and damping. The ordinate should be clearly labeled with title and units of measurement.

13.1.10.2 Temperature, frequency, or time should be plotted on the abscissa, increasing from left to right. The abscissa should be clearly labeled with title and units of measurement.

13.1.10.3 Transition temperatures are taken from the peak values in the loss modulus profile.

13.1.10.4 Wherever possible, each thermal effect should be identified and supplementary supporting evidence reported.

13.1.11 Average values and standard deviations of elastic (or relative rigidity) and loss modulus (or damping) reported to two significant figures.

13.1.12 Date of test.

13.1.13 Maximum strain amplitude and frequency.

13.1.14 Equations used to calculate values.

## 14. Keywords

14.1 dynamic mechanical; modulus; rheological; tan delta; viscoelastic

**SUMMARY OF CHANGES**

This section identifies the location of selected changes to this practice. For the convenience of the user, Committee D20 has highlighted those changes that may impact the use of this practice. This section may also include descriptions of the changes or reasons for the changes, or both.

*D 4065 – 01:*

(1) Title has been changed.

(2) ISO statement has been added.

(3) Footnote C in Table 1 has been changed. Company name change.

(4) Summary of Changes section added.

*ASTM International takes no position respecting the validity of any patent rights asserted in connection with any item mentioned in this standard. Users of this standard are expressly advised that determination of the validity of any such patent rights, and the risk of infringement of such rights, are entirely their own responsibility.*

*This standard is subject to revision at any time by the responsible technical committee and must be reviewed every five years and if not revised, either reapproved or withdrawn. Your comments are invited either for revision of this standard or for additional standards and should be addressed to ASTM International Headquarters. Your comments will receive careful consideration at a meeting of the responsible technical committee, which you may attend. If you feel that your comments have not received a fair hearing you should make your views known to the ASTM Committee on Standards, at the address shown below.*

*This standard is copyrighted by ASTM International, 100 Barr Harbor Drive, PO Box C700, West Conshohocken, PA 19428-2959, United States. Individual reprints (single or multiple copies) of this standard may be obtained by contacting ASTM at the above address or at 610-832-9585 (phone), 610-832-9555 (fax), or [service@astm.org](mailto:service@astm.org) (e-mail); or through the ASTM website ([www.astm.org](http://www.astm.org)).*