



Standard Practice for Performing Outdoor Accelerated Weathering Tests of Plastics Using Concentrated Sunlight¹

This standard is issued under the fixed designation D 4364; the number immediately following the designation indicates the year of original adoption or, in the case of revision, the year of last revision. A number in parentheses indicates the year of last reapproval. A superscript epsilon (ε) indicates an editorial change since the last revision or reapproval.

1. Scope

1.1 This practice covers the use of Fresnel-reflecting concentrators that use the sun as a source of ultraviolet (UV) and longer-wavelength radiation. Such devices are used in the outdoor-accelerated-exposure testing of plastics.

1.2 This practice provides a procedure for performing outdoor-accelerated-exposure testing of plastics using a Fresnel-reflector outdoor-accelerated weathering test machine. The apparatus is described herein and in Practice G 90 more completely.

1.3 This practice is applicable to a range of plastic materials including, but not limited to, plastic films, sheets, laminates, and extruded and molded products in a variety of shapes and sizes, as specified in 8.2 and 8.3.

1.4 This practice describes test conditions that attempt to simulate plastics exposures in desert and subtropical climates. Specimen preparation, property testing procedures, and the evaluation of results are covered in existing test methods or specifications for specific materials.

1.5 *This standard does not purport to address all of the safety concerns, if any, associated with its use. It is the responsibility of the user of this standard to establish appropriate safety and health practices and determine the applicability of regulatory limitations prior to use.* Specific precautionary statements are given in Section 7.

NOTE 1—This standard and ISO 877.2-1991, Method C, are technically equivalent.

2. Referenced Documents

2.1 ASTM Standards:

D 859 Test Method for Silica in Water²

D 883 Terminology Relating to Plastics³

D 1293 Test Methods for pH of Water²

D 1435 Practice for Outdoor Weathering of Plastics³

¹ This practice is under the jurisdiction of ASTM Committee D20 on Plastics and is the direct responsibility of Subcommittee D20.50 on Durability of Plastics.

Current edition approved December 10, 2002. Published February 2003. Originally approved in 1984. Last previous edition approved in 1994 as D 4364 – 94.

² *Annual Book of ASTM Standards*, Vol 11.01.

³ *Annual Book of ASTM Standards*, Vol 08.01.

D 1600 Terminology for Abbreviated Terms Relating to Plastics³

D 1898 Practice for Sampling of Plastics⁴

D 4141 Practice for Conducting Accelerated Outdoor Exposure Tests of Coatings⁵

D 4517 Test Method for Low-Level Total Silica in High-Purity Water by Flameless Atomic Absorption Spectroscopy⁶

E 772 Terminology Relating to Solar Energy Conversion⁷

E 824 Method for Transfer of Calibration from Reference to Field Pyranometers⁷

G 7 Practice for Atmospheric Environmental Exposure Testing of Nonmetallic Materials⁸

G 24 Practice for Conducting Natural Light Exposures Under Glass⁸

G 90 Practice for Performing Accelerated Outdoor Weathering of Nonmetallic Materials Using Concentrated Natural Sunlight⁸

G 113 Terminology Relating to Natural and Artificial Weathering Tests of Nonmetallic Materials⁸

2.2 ISO Standard:⁹

ISO 877.2-1991, Method C, Methods of Exposure to Direct Weathering, to Weathering Using Glass-Filtered Daylight, and to Intensified Weathering Using Fresnel Mirrors

3. Terminology

3.1 *Definitions*—For definitions of technical terms pertaining to plastics used in this practice, see Terminologies D 883, D 1600, G 113, and E 772.

4. Significance and Use

4.1 This practice involves the concentration of sunlight by a system of plane mirrors, arranged to simulate a parabolic trough focused on an air-cooled target board on which the test

⁴ Discontinued; see 1997 *Annual Book of ASTM Standards*, Vol 08.01.

⁵ *Annual Book of ASTM Standards*, Vol 06.01.

⁶ *Annual Book of ASTM Standards*, Vol 11.02.

⁷ *Annual Book of ASTM Standards*, Vol 12.02.

⁸ *Annual Book of ASTM Standards*, Vol 14.04.

⁹ Available from American National Standards Institute (ANSI), 25 W. 43rd St., 4th Floor, New York, NY 10036.

specimens are mounted. Exposure methods with and without water spray that are commonly used for this method are described in Table 1. Other exposure cycles not listed in Table 1 can be used, upon consensual agreement between interested parties.

4.1.1 Accelerated-outdoor exposure tests performed using this practice in an absence of a programmed moisture cycle are intended to simulate conventional exposure testing on racks facing the equator in desert and arid regions.

4.1.2 Accelerated-outdoor exposure tests performed using this practice with a programmed moisture shall possess the feature of spraying high-purity water on the specimens in a regular, periodic fashion that is intended to simulate the results of conventional exposure testing on fixed racks facing the equator in subtropical, semi-humid, and temperate regions. Water-spray cycles that are recommended by this practice are given in Table 1.

4.2 The effectiveness of the Fresnel-reflector accelerated-outdoor-weathering test machines depends primarily on the amount and character of the UV in the direct-beam component of sunlight.

NOTE 2—Use of the apparatus in regions of moderate- to high-diffuse irradiance will reduce the test machine’s effectiveness substantially for providing concentrated UV in the target (specimen) area.

4.3 Testing to specific levels (quantities) of solar-ultraviolet-radiant exposure is recommended. Elapsed-time-exposure-level determinations shall not be used for testing with this practice. Testing to specific levels of UV irradiation, whether to total UV or within selected wavebands, is an effective method for improving agreement between wintertime and summertime testing on the Fresnel-reflector weathering-test machines. Other seasonal factors such as temperature and time of wetness can affect the weathering of test specimens significantly.

4.4 The weathering machines described provide for specimen cooling that reduces thermal problems in most materials. It is recommended that monthly temperature measurements be performed on heat-sensitive plastics to record the typical monthly test specimen temperatures.

NOTE 3—It is possible for heat-sensitive plastic materials and thick specimens that are self-insulating to exhibit thermal-induced degradation that is unrealistic compared to natural weathering. Clear, thin-film photodegradable plastics are not recommended for testing with this practice for this reason.

4.5 Since the natural environment varies with respect to time, geography, and topography, it may be expected that the effects of natural exposure will vary accordingly. Furthermore,

all materials are not affected equally by increased irradiance and temperature. The quantitative correlation between exposures conducted in accordance with this practice and those conducted under specified natural exposure conditions will therefore vary with the type and composition of the material.

4.6 While reference materials tested in accordance with Practices G 7 and D 1435 may be useful for providing information on the relationship between accelerated and real-time tests, the acceleration factor found for the reference material cannot be used to extrapolate results of the accelerated test to predict lifetimes under natural exposure except for the specific material for which the relationship has been established.

5. Apparatus

5.1 The testing apparatus shall be a Fresnel-reflecting device possessing ten flat mirrors that focus direct sunlight onto an air-cooled specimen area. A more complete description of the apparatus may be found in Practice G 90. See Fig. 1.

NOTE 4—The apparatus should be operated in dry, sunny climates receiving 3500 to 4000 h or more of sunshine per year and an average annual relative humidity of approximately 30 % or less.

5.2 Water Quality:

5.2.1 The purity of water used for specimen spray is very important. Without proper treatment to remove cations, anions, organics, and particularly silica, exposed panels will develop spots or stains that do not occur in exterior exposures.

5.2.2 Water used for specimen spray shall leave no objectionable deposits or stains on the exposed specimens. It is strongly recommended that the water contain below 1 ppm solids and below 0.2 ppm silica. Silica levels should be determined in accordance with the procedures in Test Methods D 859 or D 4517. Prepackaged analysis kits are commercially available that are capable of detecting silica levels of below 200 ppb. A combination of deionization and reverse-osmosis treatment can produce water with the desired purity effectively. The solids and silica levels must be reported if the spray water used is above 1 ppm solids.

5.2.3 If specimens are found to have deposits or stains after exposure in the apparatus, the water purity must be checked to determine if it meets the requirements above. On some occasions, exposed specimens can be contaminated by deposits from bacteria that can grow in the purified water used for specimen spray. If bacterial contamination is detected, the entire system used for specimen spray must be flushed with chlorine and thoroughly rinsed before resuming exposures. Although it does not always correlate with silica content, it is

TABLE 1 Fresnel-Reflector Test Machine Standard Spray Cycles

Cycle	Daytime			Nighttime		
	Spray Duration	Dry-Time Duration	Cycles, h	Spray Duration	Dry-Time Duration	Cycles, h
1	8 min	52 min	1	8 min	172 min	water is sprayed on the test specimens at: 9:00 p.m. 12:00 midnight 3:00 a.m.
2	no water spray used			no water spray used		
3 ^A	no water spray used			3 min	12 min	4 cycles per hour (from 7PM to 5 AM)

^A This is the cycle specified in Procedure C of Practice D 4141.

- | | |
|--------------------------|-----------------------------|
| A - AIR PLENUM | H - MAST, AZIMUTH ADJUST |
| B - AIR BLOWER | I - AIR FLOW SWITCH |
| C - ROTOR ASSEMBLY | J - WATER SPRAY NOZZLE |
| D - AIR DEFLECTOR | K - CLUTCH DISC, ELEV DRIVE |
| E - A-FRAME ASSEMBLY | L - SOLAR CELLS/SHADOW HAT |
| F - MIRROR | M - SAMPLE PROTECTION DOOR |
| G - GEAR BOX, ELEV DRIVE | N - DOOR RELEASE MECHANISM |

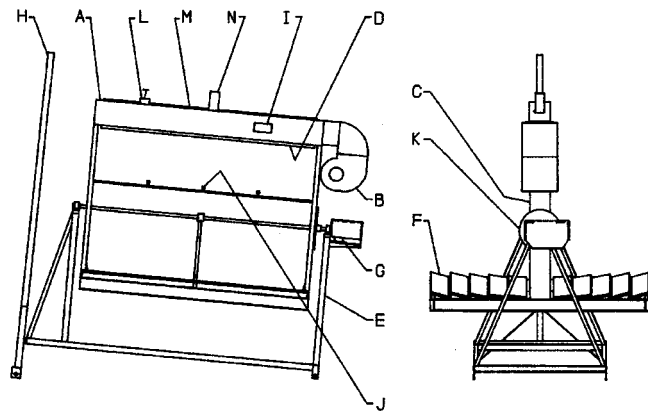

- | | |
|-----------------------------|-------------------------------|
| A—Fresnel-Reflecting Mirror | H—Center of Rotation |
| B—Water Spray Nozzle | J—Reversible Motor/Gear Drive |
| C—Air Tunnel | K—Clutch |
| D—Squirrel Cage Blower | L—Altitude-Adjustment Mast |
| E—Air Switch | M—Mirror Bed/Frame |
| F—Solar Cell Tracker | N—Anchors |
| G—Specimens on Target Board | P—A-Frame |

FIG. 1 Schematic of a Fresnel-Reflecting Concentrator-Accelerated Weathering Machine

recommended that resistivity of water used for specimen spray be continuously monitored and that exposures be discontinued whenever the resistivity falls below 1 MΩ.

6. Reagents and Materials

6.1 Water shall conform to the specifications presented in 5.2.1-5.2.3.

6.2 The mirrors used on Fresnel-reflector test machines shall be flat and have a specular UV reflectance of 65 % or greater at 310 nm wavelength.

7. Safety Precautions

7.1 Suitable eye protection shall be required when working with Fresnel-reflector test machines to prevent UV and infrared damage. Manipulation of the reflectors for daily maintenance, or for the purpose of specimen mounting, dismounting, and inspection, can reflect the concentrated sunlight on the face accidentally. The use of sunglasses that absorb most of the UV radiation below 360-nm wavelength is essential; aluminized glasses will prevent accidental burning of the retina by infrared.

7.2 Suitable clothing or sunscreen ointments having an SPF of 15 or higher, or both, should be used to cover exposed skin for persons working with the test machines described in this practice.

7.3 The squirrel-cage blower shall be covered with a heavy-duty protective screen to prevent accidental injury and to keep loose clothing from the fan during startup, shutdown, maintenance, inspection, or specimen exchange.

8. Test Specimens

8.1 Users of this accelerated outdoor exposure practice should follow the statistical procedures for sampling presented in Practice D 1898.

8.2 The target dimensions presently used for most Fresnel-reflector accelerated-weathering machines are 130 by 1400 mm. The target dimensions shall dictate the test specimen dimensions.

8.3 The air cooling process and mechanism dictates that the thickness of test specimens should be limited to 13 mm. The adequacy of cooling may be questionable for test specimens thicker than 13 mm.

8.4 Test specimens smaller than the maximum size may be arranged as shown in Practice G 90.

9. Procedures

9.1 Mounting:

9.1.1 Mount the test specimens in a suitable frame such that a minimum of the test specimen is covered by the clamping fixture used.

NOTE 5—A masked area or specimen overlapping should not be used in an attempt to estimate the effects of a dark exposure at the same temperature since a masked area or specimen overlapping is not unexpected and the temperature may actually be higher than the unmasked areas.

9.1.2 Mount the framed test specimens approximately 5 mm off the target board. Position the specimen such that adequate clearance is maintained between the air delivery slot and the frame. Adjust the machine's air deflector to provide a clearance from 6 to 13 mm between the exposed surface of the test specimen and the air deflector lip. Plastic test specimens with widely disparate thicknesses should not be mounted on the same test machine in order to provide for uniform cooling.

9.1.3 When mounting plastic specimens under glass to simulate the types of exposures under glass covered in Practice G 24, ensure that the solar spectral transmittance (particularly in the UV region from 295 to 385-nm wavelength) of the glass used is essentially identical to that used in natural weathering with which it is being compared, or that its spectral transmittance is that required for the application. Mount the glass covers, or plastic transparencies (if the application calls for a transparency other than glass), such that they cover the entire specimen with respect to the reflected light from all of the mirrors. Mount the transparent covers at a distance of 25 to 32 mm from the specimen surface. Common practice is to mount the transparent cover at a distance of 25 mm from flat, plastic specimens, and to use a greater distance for non-flat specimens (see Fig. 2). This distance is close enough to the specimen to block all reflected solar irradiance and still allows for adequate cooling.

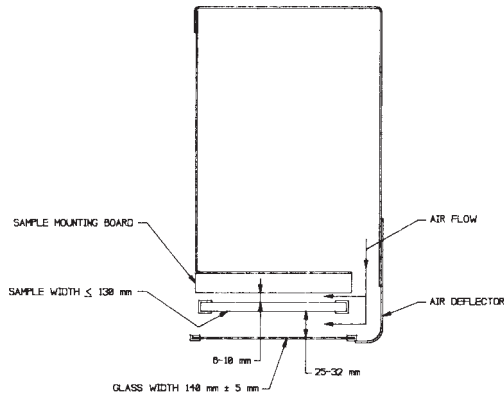

FIG. 2 Schematic Cross Section of Underglass Specimen Mounting

NOTE 6—Under-glass (or under-plastic) exposure tests in accordance with 4.1.1 require careful adjustment of the cooling vanes (etc.) to achieve adequate specimen cooling. Specimen temperature and air velocity measurements can be used to verify whether the specimens have adequate cooling.

9.2 Operation:

9.2.1 Begin the test by moving the Fresnel device to solar acquisition. Actuate the water-spray system as required. See Table 1 for selection of spray schedule. Record the solar irradiance data while the device is operated.

9.2.2 Perform the testing in accordance with the daily schedule described in Practice G 90.

9.2.3 Measure the direct beam solar radiation using a solar tracking 6° pyrhelimeter. This solar radiometer shall be calibrated at least annually in accordance with Test Method E 824.

9.3 Expose the specimens for a predetermined amount of UV radiant exposure measured in joules per square metre. Determine the solar-radiant exposure of the test specimens in accordance with the following formulae:

$$H_s = M\rho_s \sum_{i=1}^N H_d \tag{1}$$

$$\rho_s = \frac{\rho}{M} \sum_{i=1}^M \cos \theta_i \tag{2}$$

where:

- H_s = solar radiant exposure, J/m²,
- M = number of mirrors,
- ρ_s = cosine-corrected specular reflectance,
- ρ = average energy weighted specular reflectance of the mirrors,
- N = number of days of exposure,
- θ_i = angle of incidence of the irradiance from each mirror at the specimen target area, and
- H_d = direct-normal daily solar-radiant exposure measured in a 6°-field of view.

Refer to Practice G 90 to determine the UV (295 to 385 nm) solar radiant exposure, H_d in (Eq 1).

9.4 Caution should be exercised in permitting long unexposed periods to elapse prior to re-exposing many polymeric and pigmented plastic materials that may exhibit dark reactions, dark reversals, etc.

10. Report

10.1 Include the following as a minimum in the report:

- 10.1.1 Laboratory;
- 10.1.2 Site latitude;
- 10.1.3 Specimen description;
- 10.1.4 Test method and sequence of test events;
- 10.1.5 Operating-spray cycle;
- 10.1.6 Specimen mounting;
- 10.1.7 Total solar-radiant exposure, MJ/m² (295 to 3000 nm);
- 10.1.8 Solar-ultraviolet-radiant exposure, MJ/m² (295 to 385 nm);
- 10.1.9 Instrumentation used for measuring ultraviolet-radiant exposure;
- 10.1.10 Black-panel temperature, if recorded, °C;
- 10.1.11 Elapsed exposure time, days;
- 10.1.12 Inclusive days of exposure; and
- 10.1.13 Observations, deviations, and waivers pertinent to the testing.

11. Keywords

- 11.1 Fresnel-reflector system; natural weathering; plastic; pyrhelimeter

ASTM International takes no position respecting the validity of any patent rights asserted in connection with any item mentioned in this standard. Users of this standard are expressly advised that determination of the validity of any such patent rights, and the risk of infringement of such rights, are entirely their own responsibility.

This standard is subject to revision at any time by the responsible technical committee and must be reviewed every five years and if not revised, either reapproved or withdrawn. Your comments are invited either for revision of this standard or for additional standards and should be addressed to ASTM International Headquarters. Your comments will receive careful consideration at a meeting of the responsible technical committee, which you may attend. If you feel that your comments have not received a fair hearing you should make your views known to the ASTM Committee on Standards, at the address shown below.

This standard is copyrighted by ASTM International, 100 Barr Harbor Drive, PO Box C700, West Conshohocken, PA 19428-2959, United States. Individual reprints (single or multiple copies) of this standard may be obtained by contacting ASTM at the above address or at 610-832-9585 (phone), 610-832-9555 (fax), or service@astm.org (e-mail); or through the ASTM website (www.astm.org).