



Designation: ~~D 4894—98a~~ 4894 – 04

## Standard Specification for Polytetrafluoroethylene (PTFE) Granular Molding and Ram Extrusion Materials <sup>1</sup>

This standard is issued under the fixed designation D 4894; the number immediately following the designation indicates the year of original adoption or, in the case of revision, the year of last revision. A number in parentheses indicates the year of last reapproval. A superscript epsilon ( $\epsilon$ ) indicates an editorial change since the last revision or reapproval.

### 1. Scope\*

1.1 This specification covers granular resins and test methods for polytetrafluoroethylene (PTFE) that have never been preformed or molded and are normally processed by methods similar to those used in powder metallurgy or ceramics, or by special extrusion processes. These PTFE resins are homopolymers of tetrafluoroethylene, or, in some cases, modified homopolymers containing not more than one percent by weight of other fluoromonomers. The usual methods of processing thermoplastics generally are not applicable to these materials because of their viscoelastic properties at processing temperatures. The materials included herein do not include mixtures of PTFE resin with additives such as colorants, fillers or plasticizers; nor do they include reprocessed or reground resin or any fabricated articles. The methods and properties included are those required to identify the various types of resins. Additional procedures are provided in the Appendix for further characterization of the resins.

1.2 The values stated in SI units as detailed in IEEE/ASTM SI-10 are to be regarded as the standard, and the practices of IEEE/ASTM SI-10 are incorporated herein.

1.3 The following precautionary caveat pertains only to the Specimen Preparation section, Section 9, and the Test Methods section, Section 10, of this specification: *This specification does not purport to address all of the safety concerns, if any, associated with its use. It is the responsibility of the user of this standard to establish appropriate safety and health practices and determine the applicability of regulatory limitations prior to use.* See Notes 3 and 9 for specific cautionary statements.

NOTE 1—Information in this specification is technically equivalent to related information in ISO 12086-1 and ISO 12086-2.

<sup>1</sup> This specification is under the jurisdiction of ASTM Committee D-20 on Plastics and is the direct responsibility of Subcommittee D20.15 on Thermoplastic Materials

Current edition approved ~~Nov. 10, 1998~~; February 1, 2004. Published ~~March 1999~~; 2004. Originally ~~published as D 4894—89~~; approved in 1989. Last previous edition approved in 1998 as D 4894 – 98a.

\*A Summary of Changes section appears at the end of this standard.

## 2. Referenced Documents

### 2.1 ASTM Standards:<sup>2</sup>

- D 618 Practice for Conditioning Plastics and Electrical Insulating Materials for Testing
- D 638M Test Method for Tensile Properties of Plastics [Metric]<sup>2</sup> Plastics
- D 792 Test Methods for Density Specific Gravity (Relative Density) and Density of Plastics by Displacement
- D 883 Terminology Relating to Plastics
- D 189505 Test Methods for Density by the Density-Gradient Technique<sup>2</sup> Apparent Density, Bulk Factor, and Pourability of Plastic Materials
- D 1895 Test Methods 3295 Specification for Apparent Density, Bulk Factor, and Pourability of Plastic Materials<sup>2</sup>
- ~~D 3295 Specification for PTFE Tubing~~
- D 3892 Practice for Packaging/Packing of Plastics
- D 4441 Specification for Aqueous Dispersions of Polytetrafluoroethylene,<sup>3</sup>
- D 4591 Test Method for Determining Temperatures and Heats of Transitions of Fluoropolymers by Differential Scanning Calorimetry
- D 489745 Specification for Filled Compounds of Polytetrafluoroethylene (PTFE) Molding and Extrusion Materials
- D 4895 Specification for Polytetrafluoroethylene (PTFE) Resins Produced From Dispersion<sup>4,5</sup> Dispersion
- E 11 Specification for Wire-Cloth Sieves for Testing Purposes
- E 177 Practice for Use of the Terms Precision and Bias in ASTM Test Methods
- IEEE/ASTM SI-10-1997 Standard for Use of the International System of Units (SI): The Modern Metric System

### 2.2 ISO Standards:

- ISO 12086-1 Plastics—Fluoropolymer Dispersions and Moulding and Extrusion Materials—Part 1: Designation System and Basis for Specification<sup>4</sup>
- ISO 12086-2 Test Methods for Fluoropolymers<sup>3</sup>

## 3. Terminology

### 3.1 Definitions:

3.1.1 The terminology given in Terminology D 883 is applicable to this specification.

### 3.2 Descriptions of Terms Specific to This Standard:

- 3.2.1 *bulk density*—the mass (in grams) per litre of resin measured under the conditions of the test.
- 3.2.2 *extended specific gravity (ESG)*—the specific gravity of a specimen of PTFE material molded as described in this specification and sintered (g.v.) for an extended period of time, compared to the sintering time for the measurement of standard specific gravity (SSG), using the appropriate sintering schedule given in this specification.
- 3.2.3 *lot, n*—one production run or a uniform blend of two or more production runs.
- 3.2.4 *preforming*—compacting powdered PTFE material under pressure in a mold to produce a solid object, called a preform, that is capable of being handled. Molding and compaction are terms used interchangeably with preforming for PTFE.
- 3.2.5 *reground resin*—that produced by grinding PTFE material that has been preformed but has never been sintered.
- 3.2.6 *reprocessed resin*—that produced by grinding PTFE material that has been both preformed and sintered.
- 3.2.7 *sintering*—as it applies to PTFE, a thermal treatment during which the PTFE is melted and recrystallized by cooling with coalescence occurring during the treatment.
- 3.2.8 *skiving*—a machining operation during which a continuous film of PTFE material is peeled from the lateral surface of a cylindrical sintered molding.
- 3.2.9 *standard specific gravity (SSG)*—the specific gravity of a specimen of PTFE material molded as described in this specification and sintered using the appropriate sintering schedule given in this specification.
- 3.2.10 *thermal instability index (TII)*—a measure of the decrease in molecular weight of PTFE material which has been heated for a prolonged period of time.

## 4. Classification

- 4.1 This specification covers the following six types of PTFE generally used for compression molding or ram extrusion, or both:
  - 4.1.1 *Type I*—Resin used for general-purpose molding and ram extrusion.
  - 4.1.2 *Type II*—Finely divided resin with an average particle size less than 100 micrometers.
  - 4.1.3 *Type III*—Modified resins, either finely divided or free-flowing, typically used in applications requiring improved resistance to creep and stress-relaxation in end-use.

<sup>2</sup> For referenced ASTM standards, visit the ASTM website, [www.astm.org](http://www.astm.org), or contact ASTM Customer Service at [service@astm.org](mailto:service@astm.org). For *Annual Book of ASTM Standards*, Vol 08.01, volume information, refer to the standard's Document Summary page on the ASTM website.

<sup>3</sup> Specifications for other forms of polytetrafluoroethylene may be

<sup>3</sup> A "Vibra-Flow" Feeder, Type FT01A, Available from FMC Corporation, Material Handling Division, FMC Building, Homer City, PA 15748, has been found in Specifications D 4441 and D 4895, satisfactory for this purpose.

*Annual Book of ASTM Standards*, Vol 08.02.

<sup>4</sup> Available from American National Standards Institute (ANSI), 25 W. 43rd St., 4th Floor, New York, NY 10036.

4.1.4 *Type IV*—Free-flowing resins. Generally made by treatment of finely divided resin to produce free-flowing agglomerates.

4.1.5 *Type V*—Presintered. Resin that has been treated thermally at or above the melting point of the resin at atmospheric pressure without having been previously preformed.

4.1.6 *Type VI*—Resin, not presintered, but for ram extrusion only.

NOTE 2—See Tables 1 and 2 for division of Types by Grades, and footnotes to Tables 1 and 2 (and Table X2.1 in Appendix X2.) for former classifications.

4.2 A ~~one-line~~ line callout system ~~may be~~ is used to specify materials covered by in this specification standard. The system uses predefined cells to refer to specific aspects of this specification, illustrated as follows:

Specification							
Standard Number Block	:	Type	:	Grade	:	Class	Special notes
:		:		:		:	:
Example: ASTM D 4894 – 97		##		2			
Example: ASTM D 4894 – 04		III		2			

For this example, the line callout would be ASTM D 4894 – 9704, III2, and would specify a granular polytetrafluoroethylene that has all of the properties listed for that Type and Grade in the appropriate specified properties, Tables, or both, in this specification. In this case there is no Class item so the cell position for class is left blank. A comma is used as the separator between Standard Number and Type. Separators are not needed between Type, Grade, and Class.<sup>5</sup> Provision for Special Notes is included so that other information can will be provided when required. An example would be in Specification D 3295 where dimensions and tolerances are specified for each AWG size within Type and Class. When Special Notes are used, they should shall be preceded by a comma.

## 5. Mechanical Properties

5.1 The resins covered by this specification shall conform to the requirements prescribed in Tables 1 and 2 when tested by the procedures specified herein. Table 1 lists tests to be carried out on resins. Table 2 lists tests requiring specimens molded as described in Section 3.1.1.

## 6. Other Requirements

6.1 The resin shall be uniform and shall contain no additives or foreign material.

6.2 The color of the material as shipped by the seller shall be white.

## 7. Sampling

7.1 The resin

7.1 Sampling shall be sampled in accordance with an statistically adequate statistical sampling program. Adequate statistical sampling prior to packaging shall be considered an acceptable alternative.

7.2 The producer shall take (and test) sufficient within-lot samples to assure adequate in-process quality control and continuing conformance to satisfy the property requirements of this specification. 11.4

## 8. Number of Tests

8.1 Lot inspection shall include tests for bulk density, particle size and standard specific gravity. Periodic tests shall consist of

## Annual Book of

<sup>5</sup> See the ASTM Standards, *Form and Style Manual*, Vol 08.05, available from ASTM Headquarters.

**TABLE 1 Detail Requirements for Tests on Resins<sup>A</sup>**

Type	Grade	Bulk Density, g/L	Particle Size, Average Diameter, µm	Water Content, max, %	Melting Peak Temperature	
					Initial °C	Second °C
I	1	700 ± 100	500 ± 150	0.04	A	327 ± 10
	2	675 ± 50	375 ± 75	0.04	A	327 ± 10
II	...	...	<100	0.04	A	327 ± 10
	1	400 ± 125	<100	0.04	A	327 ± 10
III	2	850 ± 50	500 ± 100	0.04	335	327 ± 5
	1	650 ± 150	550 ± 225	0.04	A	327 ± 10
IV	2	>800	...	0.04	A	327 ± 10
	3	580 ± 80	200 ± 75	0.04	A	327 ± 10
	...	635 ± 100	500 ± 250	0.04	327 ± 10	327 ± 10
VI	...	650 ± 150	800 ± 250	0.04	335	327 ± 5

<sup>A</sup> >5°C above the second melting peak temperature.

TABLE 2 Detail Requirements for Tests on Molded Specimens

Type	Grade	Thermal Instability Index, max	Standard Specific Gravity		Tensile Strength min		Elongation at break min %
			min	max	MPa	psi	
I	1	50	2.13	2.18	13.8	2000	140
	2	50	2.13	2.18	17.2	2500	200
II	...	50	2.13	2.19	27.6	4000	300
III	4	50	2.14	2.22	28.0	4060	500
IV	1	50	2.14	2.22	28.0	4060	450
	2	50	2.14	2.18	20.7	3000	300
V	1	50	2.13	2.19	25.5	3700	275
	2	50	2.13	2.19	27.6	4000	300
	3	50	2.15	2.18	27.6	4000	200
VI <sup>A</sup>	...	NA <sup>A</sup>	NA <sup>A</sup>	NA <sup>A</sup>	NA <sup>A</sup>	NA <sup>A</sup>	NA <sup>A</sup>
VI <sup>B</sup>	...	NA <sup>A</sup>	NA <sup>A</sup>	NA <sup>A</sup>	NA <sup>A</sup>	NA <sup>A</sup>	NA <sup>A</sup>

<sup>A</sup> NA: Not Applicable by molding techniques included in this specification.  
<sup>B</sup> Extrusions of this resin may show an increased degree of clarity.

all the tests specified in Tables 1 and 2 and shall be made at least one per year.

8.2 The tests listed in Tables 1 and 2, as they apply, are sufficient to establish conformity of a material to this specification. One set of tests specimens as prescribed in Section 3 shall be considered sufficient for testing each sample. The average of the results for the specimens tested shall conform to the requirements of this specification.

### 9. Specimen Preparation

#### 9.1 Test Disks:

9.1.1 Use the die shown in Fig. 1 for the molding of test disks (Note 3). disks. The test resin should shall be near ambient temperature prior to molding (Note 6)-5). **Warning**—PTFE can evolve small quantities of gaseous products when heated above 204°C [400°F]. Some of these gases are harmful. Consequently, exhaust ventilation must be used whenever the resins are heated above this temperature, as they are during the sintering operations that are a part of this specification. Since the temperature of burning tobacco exceeds 204°C [400°F], those working with PTFE resins should ensure that tobacco is not contaminated.

9.1.2 Screen 14.5 g (for tensile properties) or 7.25 g (for electrical properties discussed in Appendix X1.7) of PTFE resin through a No. 10 hand sieve into the die. Adjust the lower plug height to allow the resin in the die can be leveled by drawing a straightedge in contact with the top of the die across the top of the die cavity. Insert the die in a suitable hydraulic press and apply pressure gradually (Note 3) until a total of 34.5 MPa [5000 psi] is attained. Hold this pressure for 3 min. Remove the disk identification on the disk at this time.

**NOTE 3—Caution:** PTFE can evolve small quantities of gaseous products when heated above 204°C (400°F). Some of these gases are harmful. Consequently, exhaust ventilation must be used whenever the resins are heated above this temperature, as they are during the sintering operations that are 3—As a part of this specification. Since the temperature of burning tobacco exceeds 204°C (400°F), those working with PTFE resins should ensure that tobacco is not contaminated.

9.1.2 Screen 14.5 g (for tensile properties) or 7.25 g (for electrical properties discussed in Appendix X1.7) of PTFE resin through a No. 10 hand sieve into the die. Adjust the lower plug height so that the resin in the die can be leveled by drawing a

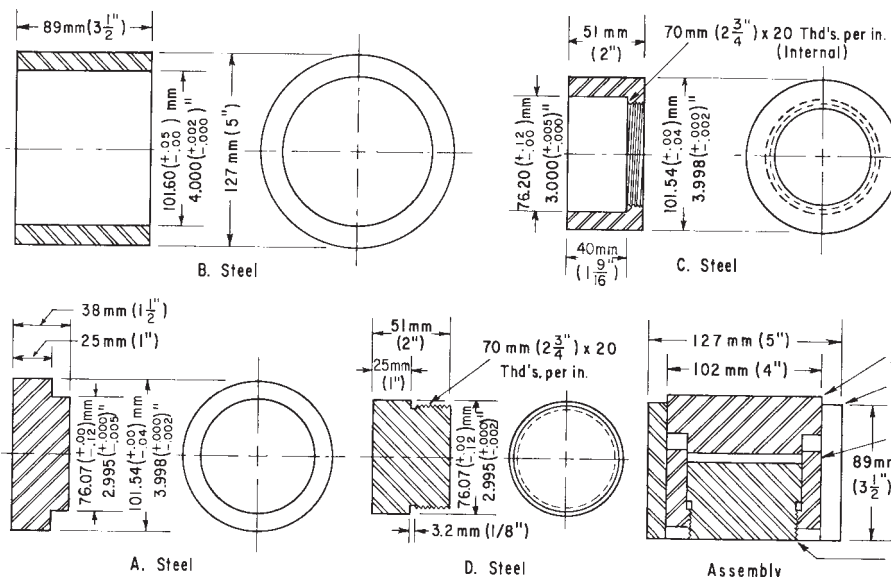

FIG. 1 Assembly and Details of Die for Molding Test Specimens

straightedge in contact with the top of the die across the top of the die cavity. Insert the die in a suitable hydraulic press and apply pressure gradually (Note 4) until a total of 34.5 MPa (5000 psi) is attained. Hold this pressure for 3 min. Remove the disk identification on the disk at this time.

NOTE 4—As a guide, increasing the pressure at a rate of 3.45 MPa (500 psi)/min is suggested until the desired maximum pressure is attained.

9.1.3 Sinter the preforms according to in accordance with Table 3 (Note 5.4).

9.1.3.1 Use Procedure B for Types I, II and IV and Procedure C for Type III.

NOTE 54—Although the rate of heating application is not critical, the cooling cycle is most important and the conditions cited in these procedures must be followed very closely. If they are not followed, the crystallinity of the disks and the resulting physical properties may will be markedly changed. Therefore, the use of a programmed oven is recommended for the most precise sintering cycle control so that the hood window may will be left down during the entire sintering procedure, the latter being an important safety consideration.

9.2 Test Specimens for Standard Specific Gravity (SSG) and Extended Specific Gravity (ESG):

9.2.1 A cylindrical preforming die, 28.6 mm (1 1/8 in.) internal diameter by at least 76.2 mm (3 in.) [3 in.] deep, is used to prepare the preforms. End plug clearances should shall be sufficient to ensure escape of air during pressing. The test resin should shall be near ambient temperature prior to molding (Note 6). 5).

NOTE 65—For maximum precision, the weighing and preforming operations should shall be carried out at 23 ± 2°C (73.4 ± 3.6°F) (the “near ambient” temperature referred to herein). These operations should shall not be performed at temperatures below about 21°C (70°F) [70°F] due to the crystalline transition that occurs in PTFE in this temperature region which leads to possible cracks in sintered specimens and differences in specimen density (as well as changes in other physical properties). Problems caused by the effects of temperature on the specific gravity or density of PTFE can will be minimized when the measurement is made using immersion procedures if a sensitive thermometer (for example, one reading ±0.1°C) is used in the liquid and the temperature is adjusted to be at least 22°C.

9.2.2 Weigh out 12.0 ± 0.1 g of resin and place it in the die. Screen non-free-flowing resins through a No. 10 sieve. ~~Compacted resins can be broken~~ Break up compacted resins by hand-shaking cold resin in a half-filled sealed glass container. Condition the resin in the sealed glass container in a freezer or dry-ice chest. After breaking up resin lumps, allow the sealed container to equilibrate to near ambient temperature. Then screen and weigh the 12.0 ± 0.1-g sample. Insert the die in a suitable hydraulic press and apply pressure gradually (Note 4) 3) until a pressure of 34.5 MPa (5000 psi) is attained. Hold this pressure for 2 min. Remove the preform from the die. A wax pencil may be used to write Write the sample identification number using an appropriate marker that will not effect the PTFE during sintering on the preform at this time.

9.2.3 Sinter the preforms according to in accordance with Table 3 (Note 5). 4).

9.2.3.1 For SSG specimens use Procedure B for Types I, II and IV and Procedure C for Type III.

9.2.3.2 For ESG specimens use Procedure F for Types I, II and IV and Procedure G for Type III.

NOTE 76—Improved precision in SSG and ESG test results has been obtained with the use of an upright, cylindrical oven and an aluminum sintering rack. The cylindrical oven has an inside diameter of 140 mm (5.5 in.) and an inside depth of 203 mm (8 in.) [8 in.] plus additional depth to accommodate a 50.8-mm (2 in.) [2 in.] thick cover, and is equipped with suitable heaters and controllers to sinter specimens according to in accordance with the Procedures in Table 3. The rack, as shown in Fig. 2, allows preforms to be placed symmetrically in the center region of the oven. Place six preforms on each of the middle oven rack shelves (if six or fewer preforms are to be sintered, place them on the middle rack, filling in with “dummies” as needed). Place “dummies” on the top and bottom shelves. Specimens must be spaced evenly in a circle on each shelf, with none of them touching. An oven load

**TABLE 3 Sintering Procedures**

	B	C	D	E	F	G	H	I
Initial temperature, °C (°F)	290 (554)	290 (554)	238 (460)	238 (460)	290 (554)	238 (460)	238 (460)	238 (460)
Initial temperature, °C [°F]	290 [554]	290 [554]	238 [460]	238 [460]	290 [554]	238 [460]	238 [460]	238 [460]
Rate of heating, °C/h (°F/h)	120 ± 10	120 ± 10	60 ± 5	60 ± 5	120 ± 10	60 ± 5	60 ± 5	60 ± 5
Rate of heating, °C/h [°F/h]	120 ± 10 (216 ± 18)	120 ± 10 (216 ± 18)	60 ± 5 (108 ± 9)	60 ± 5 (108 ± 9)	120 ± 10 (216 ± 18)	60 ± 5 (108 ± 9)	60 ± 5 (108 ± 9)	60 ± 5 (108 ± 9)
Hold temperature, °C (°F)	380 ± 6	357 ± 8	371 ± 6	360 ± 6	380 ± 6	357 ± 8	380 ± 6	371 ± 6
Hold temperature, °C [°F]	380 ± 6 (716 ± 10)	357 ± 8 (675 ± 15)	371 ± 6 (700 ± 10)	360 ± 6 (685 ± 10)	380 ± 6 (716 ± 10)	357 ± 8 (675 ± 5)	380 ± 6 (716 ± 10)	371 ± 6 (700 ± 10)
Hold time, min	30 + 2, -0	30 + 2, -0	240 ± 15	240 ± 15	360 ± 5	240 ± 15	960 ± 15	120 ± 5
Cooling rate, °C/h (°F/h)	60 ± 5	60 ± 5	60 ± 5	60 ± 5	60 ± 5	60 ± 5	60 ± 5	60 ± 5
Cooling rate, °C/h [°F/h]	60 ± 5 (108 ± 9)	60 ± 5 (108 ± 9)	60 ± 5 (108 ± 9)	60 ± 5 (108 ± 9)	60 ± 5 (108 ± 9)	60 ± 5 (108 ± 9)	60 ± 5 (108 ± 9)	60 ± 5 (108 ± 9)
Final or second hold temperature, °C (°F)	294 ± 6	294 ± 6	238 ± 6	238 ± 6	294 ± 6	238 ± 6	238 ± 6	238 ± 6
Final or second hold temperature, °C [°F]	294 ± 6 (561 ± 10)	294 ± 6 (561 ± 10)	238 ± 6 (460 ± 10)	238 ± 6 (460 ± 10)	294 ± 6 (561 ± 10)	238 ± 6 (460 ± 10)	238 ± 6 (460 ± 10)	238 ± 6 (460 ± 10)
Second hold time, min	24 + 0.5, -0	24 + 0.5, -0	NA <sup>A</sup>	NA <sup>A</sup>	24 + 0.5, -0	NA <sup>A</sup>	NA <sup>A</sup>	NA <sup>A</sup>
Period to room temperature, min, h	1/2	1/2	6	6	1/2	6	6	6

<sup>A</sup> NA, Not applicable.



9.3.2.1 Adjust the lower plug position using a support ring to position the mold shell so that the resin level will not come within 13 mm (0.5 in.) of the top of the mold cavity. Add the resin to the mold, insert the top plug, and apply hand pressure. Remove the support ring, and place the mold in a hydraulic press.

9.3.2.2 Apply an initial pressure of 3.45 MPa (500 psi) ± 10 % and hold for 1 to 2 min. Increase the pressure smoothly to the final preforming pressure in 3 to 5 min. Do not allow the mold shell to contact either press platen at any time during this preforming step. The final pressure attained should be that attained, if not recommended by the manufacturer for of the particular material, otherwise use shall be 34.5 MPa (5000 psi) for Type I and 17.2 MPa (2500 psi) for Types II, III and IV. Hold under maximum pressure for 2 to 5 min. Release the pressure by gradually “cracking” the pressure release valve without an apparent movement of the press platens. Remove the top pusher and force the preform vertically out of the mold shell using a continuous, smooth movement.

NOTE 8—The preform must be removed carefully from 7—Remove the die. If mold in a continuous careful smooth movement of from the preform is not maintained, cracking of the preform may occur. die to prevent cracking.

9.3.3 Sinter the preform according to in accordance with Table 3 (Note 5)–4).

9.3.3.1 Use Procedure D for Types I, II and IV and Procedure E for Type III—except for ESG specimens.

9.3.3.2 For ESG specimens use Procedure H for Types I, II, and IV and Procedure I for Type III.

9.3.4 Divide the test billet into sections by making transverse cuts by machining, or by a suitable alternate procedure, according to in accordance with Fig. 4. The Use a saw for the rough cuts between Sections I and II and between sections III and IV may be made with a saw, IV, but Faces C and D must be prepared by machining. Prepare five test specimens for the determination of tensile properties from 0.8-mm (1/32-in.) [1/32-in.] thick slices machined from Section II, Face C, and machine a slice of suitable thickness for standard specific gravity measurements as described in 10.5. Care should shall be taken to avoid wedge-shaped cuts. Use the remainder of Section II to prepare tape specimens by skiving 0.13 mm (5 mils) thick. Discard the initial five revolutions of skived tape before taking the test sample. The Use the tape may be used for the determination of tensile properties, as an alternative to machined disks. If electrical properties, discussed in the Appendix, are to be determined on tape, Sections II and III must be left together in order that a tape of sufficient width is obtained to allow the cutting of a 50.8-mm (2-in.) [2-in.] diameter electrical test specimen.

9.4 Conditioning Test Specimens :

9.4.1 For tests of tensile properties and all tests requiring the measurement of specific gravities gravity condition the test specimens in general accordance with Procedure A of Practice D 618, with the following deviations therefrom: a) the aging period shall be a minimum of 4 h immediately prior to testing, b) the laboratory temperature shall be 23 ± 2°C (73.4 ± 3.6°F), and c) there shall be no requirement respecting humidity. The other tests require no conditioning of the molded test specimens.

9.5 Test Conditions:

9.5.1 Tests shall be conducted at the standard laboratory temperature of 23 ± 2°C (73.4 ± 3.6°F). See Note 6 5 for additional details. Since these resins do not absorb water, the maintenance of constant humidity during testing is not required.

**10. Test Methods**

10.1 Melting Characteristics by Thermal Analysis:

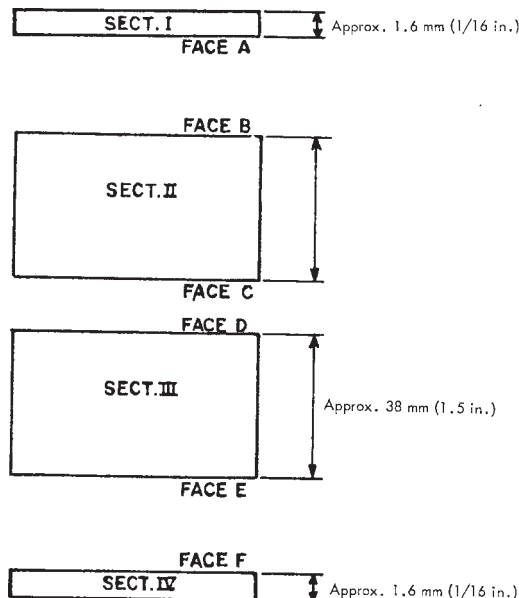

FIG. 4 Sectioned PTFE Test Billet

10.1.1 *Significance and Use*—Most of the PTFE resins that fall within the scope of this specification have never been melted (the only exception is Type V resin). These resins have higher melting peak temperatures on initial melting than on second or subsequent meltings. Since PTFE resins that have been melted prior to use behave differently from those that have not, the melting characteristics of resins provide important distinctions among them. Melting peak temperatures (see Fig. 5) are used to make these distinctions, and determine conformance of a resin to the melting peak temperature requirements given in Table 1 of this specification. A resin that has been melted is not compatible with this specification, except for Type V.

10.1.2 *Apparatus*—Use apparatus described in Test Method D 4591.

10.1.3 *Procedure*:

10.1.3.1 Measure melting peak temperatures ~~according to~~ in accordance with the procedures given in Method D 4591. An initial melting peak temperature above the melting peak temperature obtained on the second and subsequent melting (defined as the second melting peak temperature) indicates that the resin was not melted before the test. The second melting peak temperature occurs at about 327°C (621°F). Usually the difference between the initial and second melting peak temperatures is greater than 5°C (9°F), ~~but may be slightly less,~~ [9°F], ~~as can be seen in Table 1.~~ If peak temperatures are difficult to discern from the curves, that is, if the peaks are rounded rather than pointed, straight lines ~~should~~ shall be drawn tangent to the sides of the peak. Where these lines intersect beyond the peak ~~should~~ shall be taken as the peak temperature. ~~Multiple peaks during the initial melting test may occur.~~ Where more than one peak occurs during the initial melting test, the presence of any peak corresponding to the second melting peak temperature ~~may indicate~~ indicates the presence of some previously melted material.

10.2 *Bulk Density*:

10.2.1 *Significance and Use*—Bulk density gives some indication of how a resin ~~may~~ will perform during feeding of molding and ram extrusion equipment. PTFE resins have a tendency to compact during shipment and storage, and even though the material is broken up by screening or some other means, original “as produced” results ~~may be not be duplicated,~~ guaranteed. Because of this tendency to pack under small amounts of compression or shear, Test Method D 1895 is not applicable to these resins. The procedure given in the following paragraphs must be used to measure this property.

10.2.2 *Apparatus*:

10.2.2.1 *Funnel*—A funnel arrangement as shown in Fig. 6.

10.2.2.2 *Feeder*<sup>3</sup> —A feeder with a No. 8 wire screen placed over approximately the top two-thirds of the trough. The funnel shall be mounted permanently in the feeder outlet.

10.2.2.3 *Controller*<sup>6</sup>

10.2.2.4 *Volumetric Cup and Cup Stand* (Fig. 7)—The volumetric cup shall be calibrated initially to 250 mL by filling it with distilled water, placing a planar glass plate on top, drying the outside of the cup, and weighing. The net weight shall be 250 ± 0.5 g. The top and bottom faces of the volumetric cup and the cup stand shall be machined plane and parallel.

10.2.2.5 *Leveling Device*— The leveler (Fig. 8) shall be affixed permanently to the table and adjusted so that the sawtooth edge of the leveler blade passes within 0.8 mm (1/32 in.) of the top of the volumetric cup.

10.2.2.6 *Work Surface*— The work surface for holding the volumetric cup and leveler shall be essentially free from vibration. The feeder, therefore, must be mounted on an adjoining table or wall bracket.

*Annual Book of ASTM Standards, Vol 14.02.*

<sup>6</sup> A “Syntron” controller, Type SCR1B, available from FMC Corporation, address as shown in footnote 12, has been found satisfactory for this purpose.

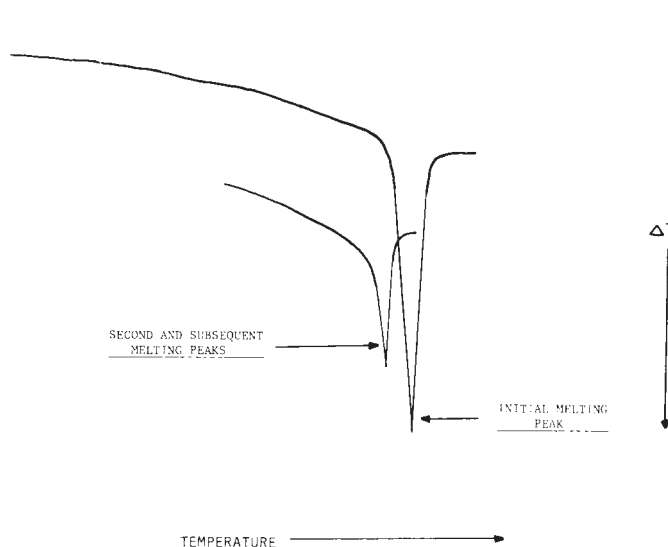
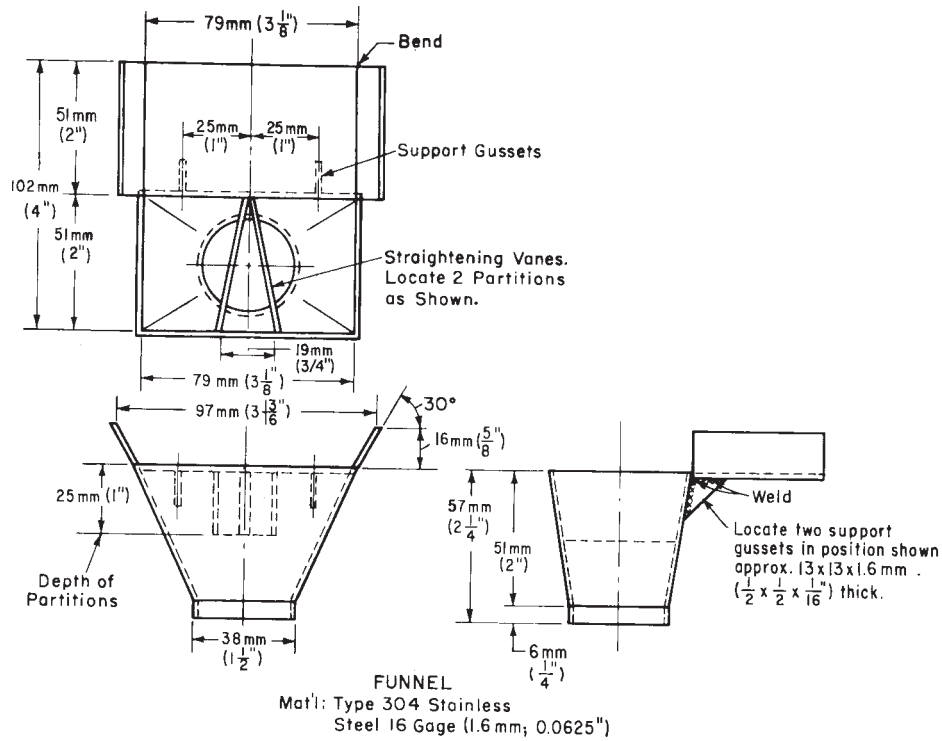
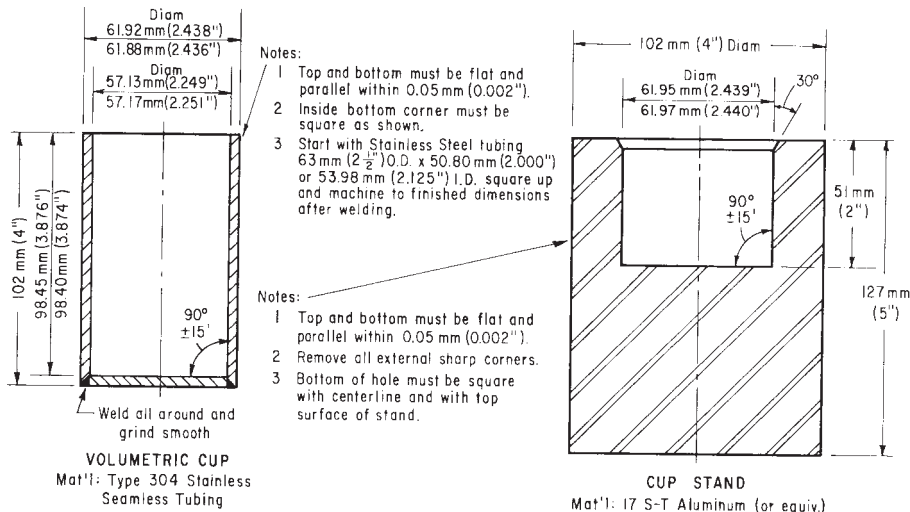

FIG. 5 Melting Characteristics by Thermal Analysis





**FIG. 6 Details of Funnel for Bulk Density Test**



**FIG. 7 Volumetric Cap and Cap Stand for Bulk Density Test**

10.2.2.7 *Balance*—The balance having an extended beam shall have a capacity of 500 g and a sensitivity of 0.1 g or equivalent.

10.2.3 *Procedure:*

10.2.3.1 Place the clean, dry volumetric cup on the extended beam of the balance and adjust the tare to zero. Select about 500 mL of the resin to be tested, place it on the feeder screen and vibrate all of the resin through the screen and back into the sample container twice to break up any lumps. Put the cup in the cup stand and place the assembly such that the distance of free polymer fall from the feeder outlet to the top rim of the cup shall be  $38.1 \pm 3.2$  mm ( $\pm [1\frac{1}{2} \pm \frac{1}{8}$  in.]). Increased fall causes packing in the cup and higher Bulk Density values. Set the controller so that the cup is filled in 20 to 30 s. Pour the sample on the vibrating screen and fill the cup so that the resin forms a mound and overflows. Let the resin settle for about 15 s and then gently push the cup and its stand beneath the leveler. Exercise care to avoid agitation of the resin and cup before leveling. Weigh the resin to the nearest 0.1 g.

10.2.4 *Calculation*— Calculate the bulk density as follows:

$$\text{Grams of resin} \times 4 = \text{bulk density (grams per litre)}$$

10.2.5 *Precision and Bias*—A precision statement for use with this procedure is under development. The procedure in this test

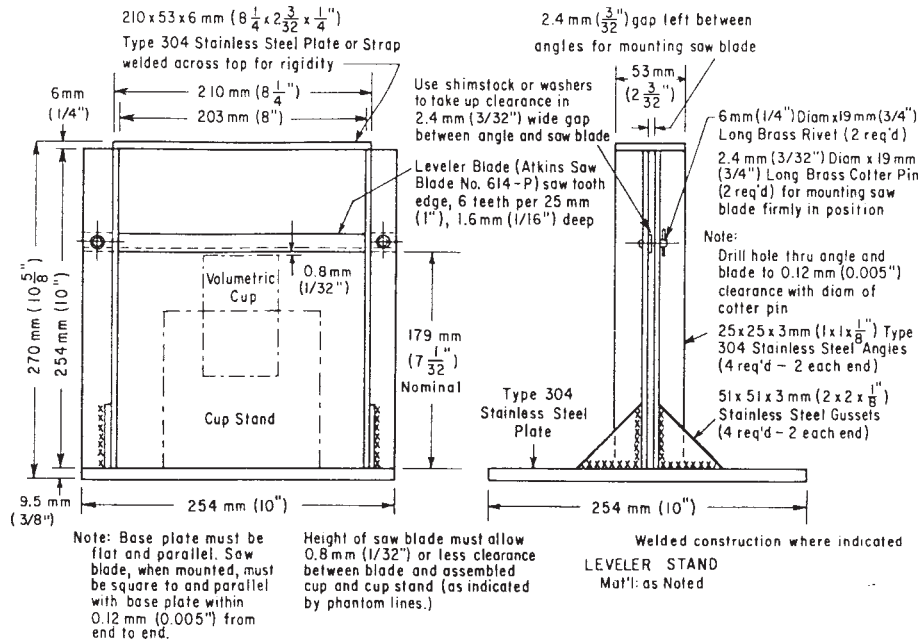

FIG. 8 Leveler Stand for Bulk Density Test

method has no bias because the value of bulk density can be defined only in terms of a test method.

10.3 Particle Size:

10.3.1 Significance and Use—The fabrication of PTFE resins either by molding or extrusion is affected significantly by particle (or agglomerate) size and size distribution. (See Appendix X1. for further details on particle characteristics.) The average particle size of PTFE resins is determined by fractionation of the material with a series of sieves. Fractionation is facilitated by spraying with perchloroethylene (Note 9) which breaks up lumps and prevents clogging of the sieve openings. **Warning**—Perchloroethylene is under investigation by government agencies and industry for its carcinogenic effects. Protective nitrile or butyl gloves shall be worn to prevent skin contact and adequate ventilation provided to remove the vapors.

NOTE 9—8—**Caution:** Perchloroethylene is under investigation by government agencies and industry for its carcinogenic effects. Protective nitrile or butyl gloves should be worn to prevent skin contact and adequate ventilation provided to remove the vapors.

10.3.2 Apparatus:

10.3.2.1 Balance—capable of weighing to  $\pm 0.1$  g.

10.3.2.2 Sieves—U.S. Standard Sieve Series, 203-mm (8-in.) [8-in.] diameter conforming to Specification E 11. Sieve Numbers shall be selected from Table 4.

10.3.2.3 Ventilated Hood.

10.3.2.4 Beakers—Six tared, 150-mL beakers.

NOTE 10—As 9—As an alternative, sieves may be tared, dried, and weighed on a balance to avoid transferring of fractionated samples to the tared beakers.

10.3.2.5 Apparatus for Sieving and Spraying —A suggested arrangement of an apparatus for recirculating perchloroethylene is shown in Fig. 9 (a). This must be located in a ventilated hood or adequately ventilated area.

10.3.3 Reagents—Perchloroethylene, 20 L (5 gal). Other liquids may be used; however, [5 gal]. The use of other liquids, their applicability and hazards associated with their use must be thoroughly investigated.

10.3.4 Procedure:

10.3.4.1 Select the appropriate sample size and combination of sieves from Table 4 for the type of resin under test. Adjust the flow rate of the perchloroethylene to  $6 \pm 0.5$  L/min.

10.3.4.2 Place the weighed resin on the top sieve and spray it with perchloroethylene for  $1 \pm 0.2$  min. The shower-head shall be about level with the top of the sieve and be moved in a circular fashion. Take care to break up all of the lumps and to wash the material from the sides of the sieve.

10.3.4.3 Remove the top sieve and place it in the hood to dry.

10.3.4.4 Repeat the procedure specified in 10.3.4.2 and 10.3.4.3 until all the sieves have been sprayed. Air-dry the sieves in the hood for 30 min or longer, or oven-dry at  $90^\circ\text{C}$  ( $194^\circ\text{F}$ ) [ $194^\circ\text{F}$ ] for 15 min and then cool to room temperature. Remove the resin from each sieve by tapping on a piece of paper as shown in Fig. 9 (b). Pour each fraction into a tared beaker and weigh to  $\pm 0.1$  g (See Note 10-9).

10.3.4.5 Record the weight of resin on each sieve.

**TABLE 4 Sieving Requirements<sup>A</sup>**

Sieve Number (opening)	Type				
	I	II <sup>B</sup>	III <sup>B</sup>	IV	V
14 (1.40 mm)	X			X	
18 (1.00 mm)	X			X	X
25 (710 μm)	X	X	X	X	X
35 (500 μm)	X			X	X
45 (355 μm)	X			X	X
60 (250 μm)	X			X	
80 (180 μm)	X			X	X
120 (125 μm)					X
170 (90 μm)		X	X		
200 (75 μm)		X	X		
230 (63 μm)		X	X		
270 (53 μm)		X	X		
325 (45 μm)		X	X		
400 (38 μm)		X	X		X
Sample size, g					
10 ± 0.1		X	X		
50 ± 0.1	X			X	X

<sup>A</sup> It is suggested that the sieves and sample size checked in a "Type" column be used when performing the sieve analysis on that particular type. However, other configurations of sieves may be used to obtain equivalent results.

<sup>B</sup> A discussion of the particular characteristics of finely divided resins is found in Appendix X1.

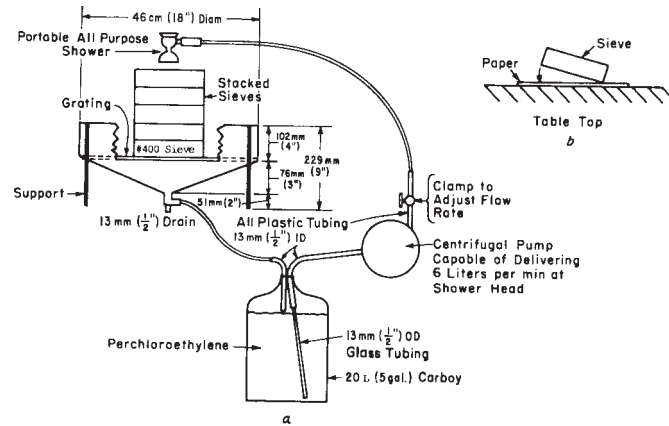

**FIG. 9 Apparatus for Particle Size Test**

10.3.4.6 Clean the sieve by inverting it over filter paper and spraying with perchloroethylene. Take care to prevent the resin from getting into the perchloroethylene.

10.3.5 Calculation— Calculate the net percentage of resin on each sieve as follows:

$$\begin{aligned} \text{Net percentage on sieve } Y & \\ &= F \times \text{weight of resin in grams on sieve } Y. \end{aligned}$$

where:

$F = 2$  for 50-g sample, and

$F = 10$  for 10-g sample.

10.3.5.1 Calculate the cumulative percentage of resin on each sieve as follows:

$$\begin{aligned} \text{Cumulative percentage on sieve } Y &= \text{sum of net percentages on sieve } Y \\ &\text{and sieves having numbers smaller than } Y. \end{aligned}$$

NOTE 140—Example—Cumulative percentage on 500 μm (No. 35) sieve for a Type V resin = net percentage on 1.00 mm (No. 18) plus net percentage on 710 μm (No. 25) plus net percentage on 500 μm (No. 35) sieves.

10.3.5.2 Plot the cumulative percentage versus the sieve opening size (or sieve number) on log-probability paper as shown in the sample plot (Fig. 10). The sieve numbers and sieve opening sizes in micrometers are indicated below the figure. Draw the best straight line through the points and read the Particle Size at the 50 % cumulative percentage point ( $d_{50}$ ).

10.3.5.3 Calculate the Particle Size, Average Diameter,  $\bar{d}$  as follows:

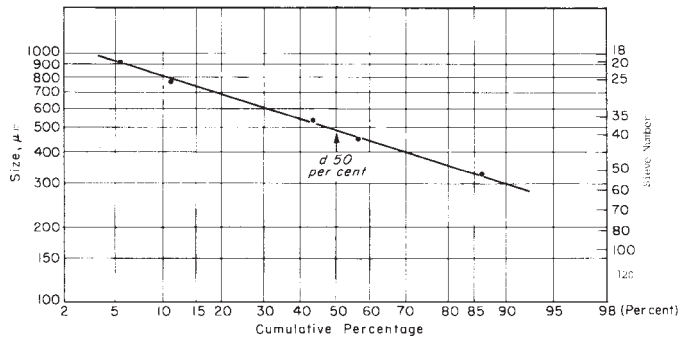

Sieve No.	Sieve Opening, $\mu\text{m}$	Sieve No.	Sieve Opening, $\mu\text{m}$
14	1400	80	180
18	1000	120	125
25	710	170	90
35	500	200	75
45	355	230	63
60	250	270	53
		325	45
		400	38

FIG. 10 Sample Plot of Cumulative Percent Versus Sieve Opening Size for Determination of Particle Size

$$\bar{d} = d_{50} \text{ (micrometers)}$$

10.3.6 Precision and Bias:

10.3.6.1 Because the resin particles have complex shapes, and because on each sieve there is a distribution of particle sizes, the values for particle size and particle size distribution obtained will be only relative numbers. The 95 % confidence limits based on a limited series of tests are  $\pm 2.8\%$  for the average particle size. Since there is no accepted reference material suitable for determination of the bias for this test procedure, no statement on bias is being made.

10.3.7 Alternative methods for particle size are available. *Light Scattering Instruments/Light Defraction Instruments* (see ISO 12086-2, 8.6.4) and *Electron Zone Sensing Instruments*, which is a resistance-variation tester, (see ISO 12086-2, 8.6.3) may be used as long as there is a direct correlation to the Particle Size Analysis in 10.3 of this specification.

10.3.7.1 This alternative method is very dependent on particle shape and is only recommended for processes that are stable and that have regular spherical type shape particles. Also, it is recommended that each manufacturing processor do an analysis to determine their own correlation.

10.4 Water Content:

10.4.1 Significance and Use—The presence of an excessive amount of water in PTFE resin has a significant adverse effect upon the processing characteristics of the resin and the quality of products made using the resin. A sample of PTFE resin of known weight is dried in a vacuum oven in a tared aluminum weighing dish. When the resin is dry, it is removed from the oven, placed in a desiccator, allowed to cool, and then reweighed. Water content is calculated from the weight lost during drying. Note 12—If volatiles other than water are suspected, use the alternative method described in 10.4.6.

10.4.2 Apparatus:

10.4.2.1 Balance, capable of weighing to the nearest 0.0001 g.

10.4.2.2 Vacuum Oven.

10.4.2.3 Aluminum Weighing Dishes, with lids.

10.4.3 Procedure (Note 131):

10.4.3.1 Wash the aluminum weighing dishes with water and rinse with acetone. When the acetone has evaporated from the dishes, dry them thoroughly in an oven at 50 to 80°C ([122 to 176°F]), then store in a desiccator until ready for use. Obtain the tare weight, B, of an aluminum weighing dish, plus lid, to the nearest 0.0001 g. Place 35 to 40 g of PTFE resin in the tared aluminum weighing dish and record the weight (including lid), A, to the nearest 0.0001 g (Note 131). Dry to constant weight in a vacuum oven—(635 mm (25 in.) Hg) [25 in. Hg] at 150°C ([302°F]), with the dish lid removed. Remove the dish from the oven, replace the lid on the weighing dish, and allow to cool in the desiccator for at least 30 min. Reweigh the dish (plus the resin and lid), C, and calculate the weight loss.

NOTE 131—Select one sample from each group of samples and run duplicate water content determinations on it. If the difference between the duplicate results exceeds 0.01 %, the entire group of samples must be run over.

NOTE 142—When a group of samples is run at the same time, it is good practice to place the lids from the weighing dishes directly under their corresponding dishes while the samples are drying in the oven. This eliminates the possibility of introducing errors in the tare weights. Also, overnight drying in a circulating air oven may be used if the data can be shown to be equivalent to those obtained with the above procedure.

10.4.4 *Calculation:*

10.4.4.1 Calculate the water content as follows:

$$\text{water content, \%} = (A - C)/(A - B) \times 100$$

where:

*A* = weight of resin, dish, and lid, g, before drying

*B* = weight of dish and lid, g and,

*C* = weight of resin, dish, and lid after drying, g.

10.4.5 *Precision and Bias:*

10.4.5.1 The precision of this test is  $\pm 0.0063\%$  (two sigma limits). Since there is no accepted reference material for determining the bias in this test procedure, no statement on bias is being made.

~~10.4.6 *Alternative Method For Determination of Water Content by Karl Fischer Reagent:*~~

~~7~~

~~10.4.6.1 Weigh  $35 \pm 1$  g of resin into a glass-stoppered flask containing about 50 mL of pretitrated methanol. Shake to mix with a swirling motion for a few minutes. Titrate with standardized Karl Fischer reagent<sup>7</sup> to a visual or electrometric end point.~~

10.5 *Standard Specific Gravity (SSG) :*

10.5.1 *Significance and Use*—The specific gravity of an article made from a PTFE resin is affected both by the particular resin used and by the way the resin is processed. Therefore, a test method that measures the specific gravity of an article prepared in a precisely defined way provides valuable resin characterization data. The specific gravity of a specimen of PTFE resin prepared according to in accordance with all of the requirements of 9.2.3.1 or 9.3.3.1 defines the SSG for that resin specimen.

10.5.2 *Procedure:*

10.5.2.1 Determine, ~~according to 10.5.2.4 or 10.5.2.5,~~ in accordance with 10.5.2.4, the specific gravity of specimens prepared in 9.2.3.1 or 9.3.3.1.

10.5.2.2 If specimens from 9.2.3.1 are to be tested, use them as is.

10.5.2.3 If specimens from 9.3.3.1 are to be tested, use the center portion of the sintered billet (Section II of Fig. 4). From it, cut an approximately cubical shape which weighs at least 10 g [for example, a cube about 17 mm-( $[0.67$  in.)] on a side].

10.5.2.4 Make specific gravity determinations in accordance with the procedures described in Test Methods D 792, Method A-1. Add two drops of a wetting agent<sup>7</sup> to the water in order to reduce the surface tension and ensure complete wetting of the specimen.

~~10.5.2.5 *Specific Gravity by Density Gradient Technique*—When the better precision of 10.5.2.4 is not required, the density gradient test described in Test Method D 1505 may be used.~~

10.6 *Thermal Instability Index (TII) :*

10.6.1 *Significance and Use*—This test method compares the SSG of a resin (determined in 10.5) to its Extended Specific Gravity (ESG) (determined here). Specimens used to determine ESG are identical to those used to determine SSG, except for the differences in thermal history described in 9.2.3 and 9.3.3. The specific gravity of a specimen prepared according to in accordance with all of the requirements of 9.2.3.2 or 9.3.3.2 defines the ESG for that resin specimen.

10.6.2 *Procedure:*

10.6.2.1 Determine, ~~according to 10.5.2.4 or 10.5.2.5,~~ in accordance with 10.5.2.4, the specific gravity of specimens prepared in 9.2.3.2 or 9.3.3.2.

10.6.2.2 If specimens from 9.2.3.2 are to be tested, use them as is.

10.6.2.3 If specimens from 9.3.3.2 are to be tested, use the center portion of the billet (Section III of Fig. 4).

10.6.3 *Calculation*— Calculate the thermal instability index (TII) as

$$\text{TII} = (\text{ESG} - \text{SSG}) \times 1000$$

10.7 *Tensile Properties:*

10.7.1 *Procedure:*

10.7.1.1 Cut five tensile specimens from a disk prepared ~~according to in accordance with~~ all of the requirements of 9.1.3.1 (or from a billet prepared according to in accordance with all of the requirements of 9.3.3.1 and cut or skived as in 9.3.4), with the microtensile die described in Fig. 11. Determine the tensile strength in accordance with the procedures described in Test Method D 638, except that the initial jaw separation shall be  $22.2 \pm 0.13$  mm-( $[0.875 \pm 0.005$  in.)], and the speed of testing shall be 50 mm-( $[2$  in.)/min. Clamp the specimen with essentially equal lengths in each jaw. Determine elongation at break from the chart, expressed as a percentage of the initial jaw separation.

10.7.2 *Precision and Bias:*

10.7.2.1 A precision and bias statement for use with this procedure is under development and will be included when it has been approved by the balloting process.

<sup>7</sup> Available from American National Standards Institute, 11 W. 42nd St., 13th Floor, New York, NY 10036.

<sup>7</sup> Examples of suitable wetting agents are “Glim” detergent, B. J. Babbitt, Inc.; “Joy” detergent, Proctor and Gamble, Inc.; and “Triton” X-100, Rohm and Haas Co.

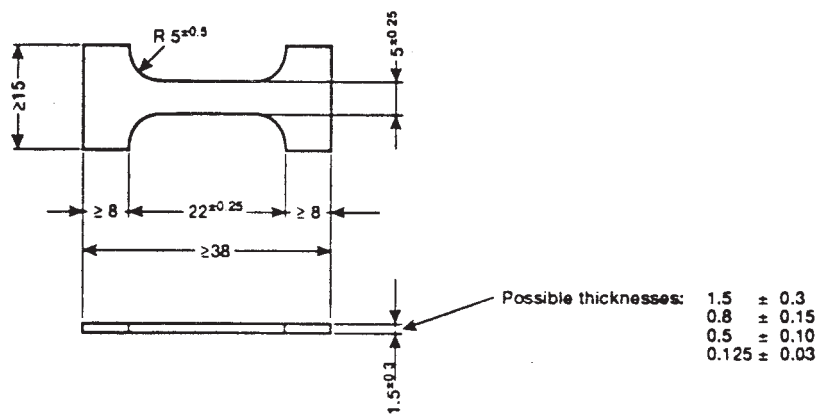
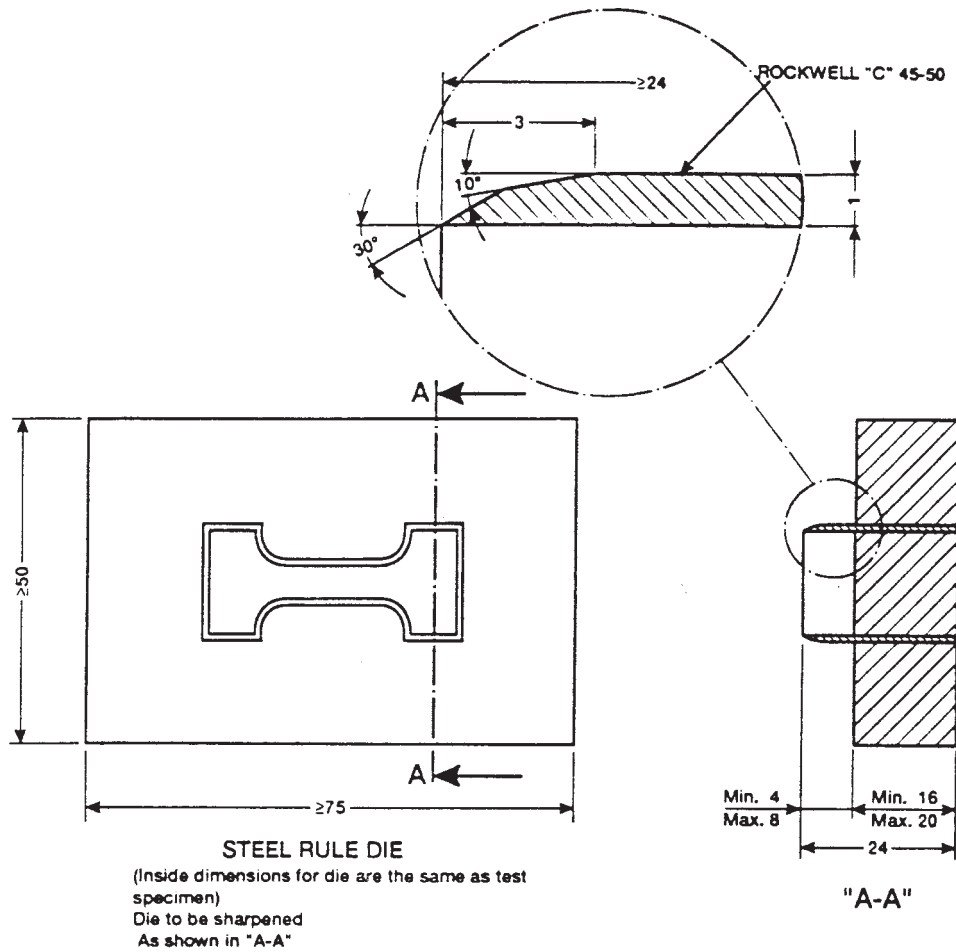

FIG. 11 Microtensile Die

**11. Inspection and Certification**

11.1 Inspection and certification of the material supplied with reference to this specification shall be for conformance to the requirements specified herein.

11.2 Lot-acceptance inspection shall be the basis on which acceptance or rejection of the lot is made. The lot-acceptance inspection shall consist of the following:

- 11.2.1 Bulk density,
- 11.2.2 Particle size,
- 11.2.3 Water content, and
- 11.2.4 Melting point.

**11.2.4 Standard Specific Gravity.**

11.3 Periodic check inspection with reference to a specification shall consist of the tests for all requirements of the material under the specification. Inspection frequency shall be adequate to ensure the material is certifiable in accordance with 11.4.

11.4 Certification shall be that the material was manufactured by a process in statistical control, sampled, tested, and inspected in accordance with this classification system, and that the average values for the lot meet the requirements of the specification (line callout).

11.5 A report of test results shall be furnished when requested. The report shall consist of results of the lot-acceptance inspection for the shipment and the results of the most recent periodic-check inspection.

**12. Packaging and Package Marking**

12.1 *Packaging*—The resin shall be packaged in standard commercial containers so constructed as to ensure acceptance by common or other carriers for safe transportation to the point of delivery, unless otherwise specified in the contract or order.

12.2 *Package Marking*— Shipping containers shall be marked with the name of the resin, type, and quantity contained therein.

12.3 All packing, packaging, and marking provisions of Practice D 3892 shall apply to this specification.

**13. Keywords**

13.1 fluoropolymers; granular polytetrafluoroethylene; polytetrafluoroethylene; PTFE

**SUPPLEMENTARY REQUIREMENTS**

The following supplementary requirements shall apply only when specified by the purchaser in the contract or order.

S1. *Ordering Information*—The purchase order ~~should~~ shall state this ASTM designation and year of issue, and which type and grade is desired.

**APPENDIX**

(Nonmandatory Information)

**X1. ADDITIONAL USEFUL TESTS**

**X1.1 Scope**

X1.1.1 In addition to their use for specification purposes, the tests described in this specification have utility for characterizing PTFE resins. Other useful properties of PTFE can be measured by adding a few details to the specification tests. The purpose of this Appendix is to provide the details needed to determine these additional characteristics. The scope is summarized in Table X1.1.

**TABLE X1.1**

Specification Test Reference	Specification Property Measured	Additional Information Available
10.5	Standard Specific Gravity	Dimensional change during molding (shrinkage and growth)
10.1	Melting Characteristics by Thermal Analysis	Heats of fusion and crystallization
10.3	Particle Size	(a) Average Particle Size for resins smaller than those covered by the standard specification (b) Percent coarse particles (percent >63 μm) in small particle size resins
10.7	Tensile Properties	Yield stress and tangent modulus at rupture Electrical Properties: Dielectric constant Dissipation factor Dielectric breakdown voltage Dielectric strength Tensile creep strain

## X1.2 Referenced Documents

### X1.2.1 ASTM Standards:

- X1.2.1.1 The following standards are referenced herein, in addition to those already listed in Section 1.1 of the Standard:
- D 150 Test Methods for A-C Loss Characteristics and Permittivity (Dielectric Constant) of Solid Electrical Insulating Materials
  - D 2990 Test Methods for Tensile, Compressive, and Flexural Creep and Creep-Rupture of Plastics
  - D 3293 Specification for PTFE Resin Molded Sheet<sup>8</sup>
  - D 3294 Specification for PTFE Resin Molded Basic Shapes<sup>8</sup>
  - D 3308 Specification for PTFE Resin Skived Tape<sup>8</sup>
  - D 3369 Specification for TFE-Fluorocarbon Resin Cast Film<sup>8</sup>

## X1.3 Dimensional Changes During Molding (Shrinkage and Growth)

X1.3.1 Measure the inside diameter (ID) to  $\pm 0.00254$  mm ( $\pm [0.0001$  in.]) of the die used to make the preform in 9.1, 9.2, or 9.3. Measure the diameter and height at the preform. After the piece has been sintered and cooled to ambient temperature, measure the diameter and height of the sintered piece.

### X1.3.2 Calculation:

X1.3.2.1 Percent mold shrinkage =  $[(\text{diameter of sintered piece}/\text{ID}) - 1] \times 100$

X1.3.2.2 Percent preform shrinkage =  $[(\text{diameter of sintered piece}/\text{diameter of preform}) - 1] \times 100$

X1.3.2.3 Percent growth =  $[(\text{height of sintered piece}/\text{height of preform}) - 1] \times 100$

X1.3.2.4 Positive values reflect an increase in the dimension during sintering. Negative values reflect a decrease in the dimension during sintering.

## X1.4 Size and Distribution of Size of Particles or Agglomerates in PTFE Resins

X1.4.1 *Average Size of Fine-Particle Size PTFE*—Wet-sieve analysis, while having disadvantages, can be used to measure the average size of Type II and Type III PTFE resins. The procedure of 10.3 ~~should~~ shall be followed using the set of sieves listed in Table 4 and a sample size of 10.0 g.

### X1.4.2 Material Retained on 63- $\mu\text{m}$ (No. 230) Sieve:

X1.4.2.1 *Scope*—A wet sieving is performed with the apparatus used for the determination of particle size, except that only three sieves are employed. This method is applicable to ultrafine resins such as Type II resins. The resin is sieved on a 63  $\mu\text{m}$  (No. 230) sieve by spraying with perchloroethylene which breaks up agglomerates and prevents clogging of the sieve openings (See Note 8) ~~7~~).

X1.4.2.2 *Apparatus*—Same as in 10.3.2, except that the following sieves are used: U.S. Standard Sieves, 850  $\mu\text{m}$  (No. 20), 63  $\mu\text{m}$  (No. 230), and 45  $\mu\text{m}$  (No. 325).

### X1.4.2.3 Procedure:

X1.4.2.4 Weigh  $10 \pm 0.01$  g of resin. Assemble the sieves as shown in Fig. 10 (a). Adjust the flow rate of the perchloroethylene to  $6 \pm 0.5$  L/min.

X1.4.2.5 Place the weighed sample on the 850  $\mu\text{m}$  (No. 20) sieve and spray with perchloroethylene for exactly 1 min using a timer. This step assists in breaking up agglomerates. Move the shower-head in a circular fashion, taking care to break up all the agglomerates and to wash the material from the sides of the sieve.

X1.4.2.6 Remove the 850  $\mu\text{m}$  (No. 20) sieve and spray the 63  $\mu\text{m}$  (No. 230) sieve for exactly 6 min, using a timer. Wash the material to the side of the sieve during the last minute.

X1.4.2.7 Dry the sieve and retained resin in an oven for 20 min or longer at 80 to 120°C ( $\pm [176$  to 248°F]). The No. 20 sieve does not require drying.

X1.4.2.8 Remove the material from the 63  $\mu\text{m}$  (No. 230) sieve by inverting on a piece of filter paper and tapping to free dry polymer. ~~A Use a stiff brush may be used~~ to help free all the material from the sieve. Pour the dried resin into a tared weighing dish and weigh to  $\pm 0.01$  g. Alternatively, determine the tare weight of the resin retained on the sieve from the difference between the gross weight after sieving and the tare weight of the sieve before sieving. A balance with a sensitivity of about 0.01 g is required for good precision.

X1.4.2.9 *Calculation*—the percentage of resin retained on the No. 230 sieve is calculated as follows:

$$\text{Amount retained, \%} = (\text{weight retained}/\text{sample weight}) \times 100$$

### X1.4.3 Distribution of Particle or Agglomerate Sizes in PTFE Resin:

X1.4.3.1 *Procedure*—Using the graph plotted in accordance with 10.3.5.2 or 10.3.5.3, draw the best smooth curve through the data points and read the values for the sizes at cumulative percentages of 16 and 84. These values, identified as  $d_{16}$  and  $d_{84}$ , are, respectively, the size of the resin at the average diameter ( $\bar{d}$ ) plus 1 sigma and ( $\bar{d}$ ) minus 1 sigma. Calculate a distribution factor (DF) and skewness (SKEW) as follows:

<sup>8</sup> See the ASTM Form

<sup>8</sup> Specifications for other forms of polytetrafluoroethylene may be found in Specifications D 4441 and Style Manual, available from ASTM Headquarters. D 4895.





$$DF = d_{16}/d_{50}$$

$$SKEW = DF/(d_{50}/d_{84})$$

X1.4.3.2 *Precision and Bias*—Because the resin particles have complex shapes, and because on each sieve there is a distribution of particle sizes, the values for particle size and particle size distribution obtained will be only relative numbers. The 95 % confidence limits based on a limited series of tests are ±2.8 % for the average particle size and ±6 % for the particle size distribution function. Since there is no accepted reference material suitable for determination of the bias for this test procedure, no statement on bias is being made.

### X1.5 Yield Behavior and Tangent Modulus at Rupture

X1.5.1 Most of the PTFE resins covered in this standard do not show a yield stress as defined in Test Method D 638. Rather than the stress-strain curve having a zero slope, the rate of increase of stress with strain decreases and then increases again. An approximate yield stress ~~can~~ shall be reported as the stress at the intersection of the two lines that best represent the initial “linear” part of the stress strain curve and the second “linear” part of the curve.

X1.5.2 *Tangent Modulus at Rupture*—The shapes of tensile stress-strain curves for PTFE resins are highly dependent on the crystallinity of the test specimen. Values for tensile strength and elongation at break do not reflect these shapes clearly. The value of the tangent to the recorded stress-strain curve measured as the best straight line from the point of rupture back along the curve is a convenient measure of the relative crystallinity of the test specimen. High values for the tangent modulus at rupture ~~( >7.6 MPa) ( >1200 psi)~~ indicate relatively low crystalline contents. As the crystallinity increases, the tangent modulus at rupture decreases until it approaches zero at high levels of crystallinity.

### X1.6 Heats of Fusion and Crystallization

X1.6.1 If the melting characteristics of the PTFE resin, as determined by Section 10.1, are determined by differential scanning calorimetry (DSC) rather than in DTA mode, additional quantitative information ~~can~~ will be obtained on the nature of the resin.

X1.6.2 Following the procedures given in Test Method D 4591 for determining heats of fusion (delta Hf) and heat of crystallization (delta Hc), measure and report delta Hf for the initial and second endotherms and delta Hc for the exotherm that is observed during controlled cooling between the two heating steps. These heats of transition, especially delta Hc, provide additional characterization of crystalline content and relative molecular weight of PTFE resins.

### X1.7 Electrical Properties

X1.7.1 Determine dielectric constant and dissipation factor in accordance with Test Method D 150. Determine dielectric breakdown voltage and dielectric strength in accordance with Test Method D 150. Typical property values for dielectric constant and dissipation factor are listed in Table X1.2. Standards for dielectric strength of sheet, basic shapes, skived tape, and film are described in Specifications D 3293, D 3294, D 3308, and D 3369, respectively.

### X1.8 Tensile Creep

X1.8.1 Determine the tensile creep of Type III materials on Test Method D 638 Type II tensile bars die cut or machined from the sheets produced in X1.8.2. Make measurements in accordance with Test Method D 2990. Conditions of test shall be 5.52 MPa ~~( <800 psi)~~ stress at the Standard Laboratory Temperature of 23 ± 2°C ~~( <73.4 ± 3°F)~~ for a test duration of a minimum of 100 h. Typical values for moldings of Type III resins would be a maximum of 4.0 % tensile creep strain after 100 h.

X1.8.2 Mold test sheets for Type III resins for tensile creep measurements in a picture frame mold having inside dimensions of 203 mm ~~( <8.0 in.)~~ square and of sufficient height to contain the sample. A frame 102 mm ~~( <4 in.)~~ [4 in.] in height has been found adequate when using 25-mm ~~( <1 in.)~~ [1-in.] thick pusher plugs to produce a sheet approximately 3 mm ~~( <1/8 in.)~~ in thickness from a resin charge of 300 g. Take care to level the resin charge in the mold. The molded sheet thickness shall be 3 mm ~~( <1/8 in.)~~.

X1.8.3 Sinter the preform ~~according to~~ in accordance with procedure E of Table 3.

TABLE X1.2 Typical Electrical Properties from Tests on Molded Specimens

	Type II	Type III
Dielectric constant, max, 1 kHz	2.1	2.1
Dissipation factor, max, 1 kHz	0.0003	0.0003

SUMMARY OF CHANGES

This section identifies the location of selected changes to this specification. For the convenience of the user, Committee D-20 has highlighted those changes that may impact the use of this specification. This section may also include descriptions of the changes or reasons for the changes, or both. ~~D 4894 – 97:~~

- (~~1~~) ~~D 4894 – 04:~~
- ~~(1)~~ Added “and test methods for” to the first sentence in 1.1.
  - ~~(2)~~ Deleted Test Method D 1505.
  - ~~(2)~~ Added “standard specific gravity (SSG)” to 3.2.2 for clarity.
  - ~~(3)~~ Added Specification D 4745.
  - ~~(3)~~ Revised wording in Note 1.
  - ~~(4)~~ Changed “Sampling” section to new definition.
  - ~~(4)~~ Table 1, Type V—changed particle size to  $500 \pm 250$ ; Type VI—changed bulk density to  $650 \pm 150$ ; Type IV—changed particle size to  $550 \pm 225$ .
  - ~~(5)~~ Removed footnote 12 and 14, and re-numbered remaining footnotes.
  - ~~(5)~~ Eliminated Section 3.2.2, Rejection and Rehearing.

~~D 4894 – 98:~~

- ~~(6)~~ Updated paragraph 11.4 with new wording.
- ~~(6)~~ Non-mandatory language removed throughout the document.
- ~~(7)~~ Changed elongation Type III, Grade I in Table 2.

~~D 4894 – 98a:~~

~~(1)~~ Added 10.3.7 and 10.3.7.1. Alternative procedures for determining particle size and distribution for particulate materials have advanced a great deal in recent years and are increasingly being used with fluoropolymers. Safety issues continue to rise with the use of perchloroethylene (see Note 9 of this specification).

~~D 4894 – 98a:~~

- ~~(1)~~ Replaced ASTM E 380 with IEEE/ASTM SI 10-1997.
- ~~(2)~~ Replaced obsolete lot definition with the new one.
- ~~(3)~~ Table 1—changed bulk density Type III, Grade 1; changed particle size Type VI.
- ~~(4)~~ Table 2—changed specific gravity Type III, Grade 1.
- ~~(5)~~ The following editorial changes were made to conform to Guide D 5740: Section 7.1, deleted reference to Practice D 1898 and replaced with appropriate wording.

Section 3.2.1, deleted current 11.1 and added wording in 11.1 through 11.4.

~~D 4894 – 98:~~

~~(1)~~ Added 10.3.7 and 10.3.7.1. Alternative procedures for determining particle size and distribution for particulate materials have advanced a great deal in recent years and are increasingly being used with fluoropolymers. Safety issues continue to rise with the use of perchloroethylene (see Warning in 10.3.1 of this specification).

~~D 4894 – 97:~~

- ~~(1)~~ Added “and test methods for” to the first sentence in 1.1.
- ~~(2)~~ Added “standard specific gravity (SSG)” to 3.2.2 for clarity.
- ~~(3)~~ Revised wording in Note 1.
- ~~(4)~~ Table 1, Type V—changed particle size to  $500 \pm 250$ ; Type VI—changed bulk density to  $650 \pm 150$ ; Type IV—changed particle size to  $550 \pm 225$ .
- ~~(5)~~ Eliminated Section 3.2.2, Rejection and Rehearing.



**D-4894 – 98a 4894 – 04**

*ASTM International takes no position respecting the validity of any patent rights asserted in connection with any item mentioned in this standard. Users of this standard are expressly advised that determination of the validity of any such patent rights, and the risk of infringement of such rights, are entirely their own responsibility.*

*This standard is subject to revision at any time by the responsible technical committee and must be reviewed every five years and if not revised, either reapproved or withdrawn. Your comments are invited either for revision of this standard or for additional standards and should be addressed to ASTM International Headquarters. Your comments will receive careful consideration at a meeting of the responsible technical committee, which you may attend. If you feel that your comments have not received a fair hearing you should make your views known to the ASTM Committee on Standards, at the address shown below.*

*This standard is copyrighted by ASTM International, 100 Barr Harbor Drive, PO Box C700, West Conshohocken, PA 19428-2959, United States. Individual reprints (single or multiple copies) of this standard may be obtained by contacting ASTM at the above address or at 610-832-9585 (phone), 610-832-9555 (fax), or [service@astm.org](mailto:service@astm.org) (e-mail); or through the ASTM website ([www.astm.org](http://www.astm.org)).*