

This document is not an ASTM standard and is intended only to provide the user of an ASTM standard an indication of what changes have been made to the previous version. Because it may not be technically possible to adequately depict all changes accurately, ASTM recommends that users consult prior editions as appropriate. In all cases only the current version of the standard as published by ASTM is to be considered the official document.



Designation: D 4895 – 9804

Standard Specification for Polytetrafluoroethylene (PTFE) Resin Produced From Dispersion ¹

This standard is issued under the fixed designation D 4895; the number immediately following the designation indicates the year of original adoption or, in the case of revision, the year of last revision. A number in parentheses indicates the year of last reapproval. A superscript epsilon (ε) indicates an editorial change since the last revision or reapproval.

¹ This specification is under the jurisdiction of ASTM Committee D-20 on Plastics and is the direct responsibility of Subcommittee D20.15 on Thermoplastic Materials

Current edition approved ~~Nov. 10, 1998~~, February 1, 2004. Published March ~~1999~~, 2004. Originally published as D 4895 – 89, approved in 1989. Last previous edition approved in 1998 as D 4895 – 978.

1. Scope*

1.1 This specification² covers dry-powder resins of polytetrafluoroethylene (PTFE) that have been prepared from dispersions of PTFE by manufacturing techniques that involve controlled coagulation of the dispersion. These resins are generally known as “fine-powder” resins or “coagulated-dispersion powder” resins. The conversion of these resins to finished products normally involves a process called “paste extrusion,” and sometimes involves formative processes such as calendaring. A volatile liquid is present as a processing aid during these formative stages of conversion, and is subsequently removed during the finishing stages of conversion. These PTFE resins are homopolymers of tetrafluoroethylene, or, in some cases, modified homopolymers containing not more than 1 % by weight of other fluoromonomers. The usual methods of processing thermoplastics generally are not applicable to these materials because of their viscoelastic properties. The materials covered herein do not include mixtures of PTFE with additives such as colors, fillers, or plasticizers; nor do they include reprocessed or reground resin or any fabricated articles because the properties of such materials have been irreversibly changed when they were fibrillated or sintered. The methods and properties included are those required to identify the various resins. An additional procedure is provided in the appendix for further characterization of the resins.

1.2 The values stated in SI units as detailed in ~~Practice E 380~~ IEEE/ASTM SI 10 are to be regarded as ~~the standard and the practices of E 380 standard. The values given in brackets are incorporated herein for information only.~~

1.3 The following safety hazards caveat pertains only to the Specimen Preparation Section, Section 9, and the Test Methods Section, Section 10, of this specification: *This standard does not purport to address all of the safety concerns, if any, associated with its use. It is the responsibility of the user of this standard to establish appropriate safety and health practices and determine the applicability of regulatory limitations prior to use.* See ~~Note 3~~ Warning note in 9.1.1 for a specific hazards statement.

NOTE 1—Information in this specification is technically equivalent to related information in ISO 12086-1 and ISO 12086-2.

2. Referenced Documents

2.1 ASTM Standards:³

D 618 Practice for Conditioning Plastics and Electrical Insulating Materials for Testing

D 638M Test Method for Tensile Properties of ~~Plastics [Metric]~~³ Plastics

D 792 Test Methods for Specific Gravity (Relative Density) of Plastics by Displacement

D 883 Terminology Relating to Plastics

D ~~189505~~ Test Methods for Apparent Density, Bulk Factor, and Pourability of Plastics by the Density-Gradient Technique³
Plastic Materials

D ~~1895~~ Test Methods 3892 Practice for Apparent Density, Bulk Factor, and Pourability of Plastic Materials³

~~D 3892 Practice for Packaging/Packing of Plastics~~

D 4052 Test Method for Density and Relative Density of Liquids by Digital Density Meter

D 4441 Specification for Aqueous Dispersions of Polytetrafluoroethylene

D 4591 Test Method for Determining Temperatures and Heats of Transitions of Fluoropolymers by Differential Scanning Calorimetry

D 4894 Specification for Polytetrafluoroethylene (PTFE) Granular Molding and Ram Extrusion Materials

E 11 Specification for Wire-Cloth Sieves for Testing Purposes

E 29 Practice for Using Significant Digits in Test Data to Determine Conformance with Specifications

E 177 Practice for Use of the Terms Precision and Bias in ASTM Test Methods⁷

~~E 380 Practice for Methods~~

IEEE/ASTM SI 10 Use of the International System of Units (SI) (The Modernized (SI): The Modern Metric System)⁷

2.2 ISO Standards:⁴

ISO 12086-1 Plastics Fluoropolymer Dispersions and Molding and Extrusion Materials—Part 1: Designation and Specification

ISO 12086-2 Plastics Fluoropolymer Dispersions and Molding and Extrusion Materials—Part 2: Preparation of Test Specimens and Determination of Properties

3. Terminology

3.1 *Definitions*—The definitions given in Terminology D 883 are applicable to this specification.

3.2 *Descriptions of Terms Specific to This Standard:*

3.2.1 *bulk density, n*—the mass in grams per litre of resin measured under the conditions of the test.

3.2.2 *extended specific gravity (ESG), n*— the specific gravity of a specimen of PTFE material molded as described in this specification and sintered (see 3.2.7) for an extended period of time, compared to the sintering time for the measurement of SSG (see 3.2.8), using the appropriate sintering schedule given in this specification.

² Specifications for other forms of polytetrafluoroethylene may be found in Specifications D 4441 and D 4894.

³ For referenced ASTM standards, visit the ASTM website, www.astm.org, or contact ASTM Customer Service at service@astm.org. For *Annual Book of ASTM Standards*, Vol 08.01, volume information, refer to the standard's Document Summary page on the ASTM website.

Annual Book of ASTM Standards, Vol 08.02.

⁴ Available from American National Standards Institute (ANSI), 25 W. 43rd St., 4th Floor, New York, NY 10036.

- 3.2.3 *lot, n*—one production run or a uniform blend of two or more production runs.
- 3.2.4 *preforming, vb*—compacting powdered PTFE material under pressure in a mold to produce a solid object, called a preform, that is capable of being handled. Molding and compaction are terms used interchangeably with preforming for PTFE.
- 3.2.5 *reground resin, n*—resin produced by grinding PTFE material that has been preformed but has never been sintered.
- 3.2.6 *reprocessed resin, n*—resin produced by grinding PTFE material that has been preformed and sintered.
- 3.2.7 *sintering, n—as it applies to PTFE*, a thermal treatment during which the PTFE is melted and recrystallized by cooling with coalescence occurring during the treatment.
- 3.2.8 *standard specific gravity (SSG), n*— the specific gravity of a specimen of PTFE material molded as described in this specification and sintered using the appropriate sintering schedule given in this specification.
- 3.2.9 *strained specific gravity (strained SG), n*—the specific gravity of a specimen of PTFE material molded, sintered, and strained as described in this specification.
- 3.2.10 *stretching void index (SVI), n*—a measure of the change in specific gravity of PTFE material which has been subjected to tensile strain as described in this specification.
- 3.2.11 *thermal instability index (TII), n*— a measure of the decrease in molecular weight of PTFE material which has been heated for a prolonged period of time.
- 3.2.12 *unstrained specific gravity (USG), n*— the specific gravity, prior to straining, of a specimen of PTFE material used in the Stretching Void Index Test (see 10.9) of this specification.

4. Classification

- 4.1 This specification covers the following types of PTFE:
 - 4.1.1 *Type I and Type II*—Resin produced from dispersion and normally used with a volatile processing aid. These resins all have the same requirements for bulk density, particle size, water content, melting peak temperature, tensile, and elongation. These resins are divided into four grades ~~according to~~ in accordance with standard specific gravity (SSG), Thermal Stability Index (TII), and Stretching Void Index (SVI). Grades are divided into classes according to extrusion pressure.

NOTE 2—See Tables 1 and 2 for details about grades and classes.

- 4.2 A ~~one-line line callout system may be~~ is used to specify materials ~~covered by~~ in this specification. The system uses predefined cells to refer to specific aspects of this specification, as illustrated as follows:

Specification				
Standard Number Block	Type	Grade	Class	Special Notes
Example: Specification D 4895 <u>D 4895 - XX</u>	I	2	C	—

For this example, the line callout would be Specification D 4895 - ~~—XX~~, I2C, and would specify a coagulated dispersion form of polytetrafluoroethylene that has all of the properties listed for that type, grade, and class in the appropriate specified properties or tables, or both, in the specification identified. A comma is used as the separator between the standard number and the type. Separators are not needed between the type, grade, and class.⁵ Provision for Special Notes is included ~~so that~~ to allow other information ~~can~~ to be provided when required. An example would be in Specification D 3295 where dimensions and tolerances are specified for each American Wire Gage (AWG) size within type and class. When special notes are used, they ~~should~~ shall be preceded by a comma.

Annual Book of

⁵ See the ASTM Standards, *Form and Style Manual*, Vol 05.02, available from ASTM Headquarters.

TABLE 1 Detail Requirements for all Types,^A Grades and Classes

Type	Bulk Density, g/L	Particle Size Average Diameter, μm	Water Content, max, %	Melting Peak Temperature, °C		Tensile Strength, min, MPa	Elongation at Break, min, %
				Initial	Second		
I	550 ± 150	500 ± 200	0.04	^B	327 ± 10	19	200
II	550 ± 150	1050 ± 350	0.04	^B	327 ± 10	19	200

^A The types, grades, and classes are not the same as those in previous editions of Specification D 4895.

^B Greater than 5.0°C above the second melting peak temperature.

TABLE 2 Detail Requirements for All Types,^A Grades and Classes

Type	Grade	Class	Standard Specific Gravity		Extrusion Pressure, MPa	Thermal Instability Index, max	Stretching Void Index, max	
			min	max				
I	1	A	2.14	2.18	5 to <15 ^B	50	NA ^C	
		B	2.14	2.18	15 to <55 ^D	50	NA ^C	
		C	2.14	2.18	15 to <75 ^E	50	NA ^C	
	2	A	2.17	2.25	5 to <15 ^B	50	NA ^C	
		B	2.17	2.25	15 to <55 ^D	50	NA ^C	
		C	2.17	2.25	15 to <75 ^E	50	NA ^C	
	3	C		2.15	2.19	15 to <75 ^E	15	200
				2.15	2.19	15 to <65 ^E	15	100
		E		2.15	2.19	15 to <65 ^E	50	200
				2.14	2.16	15 to <55 ^D	15	50
II	1	A	2.14	2.25	5 to <15 ^B	50	NA ^C	

^A The types, grades, and classes are not the same as those in previous editions of Specification D 4895.

^B Tested at a reduction ratio of 100:1 (reduction ratio is the ratio of the cross-sectional area of the preform to the cross-sectional area of the die).

^C Not applicable.

^D Tested at a reduction ratio of 400:1.

^E Tested at a reduction ratio of 1600:1.

5. Mechanical Properties

5.1 The resins covered by this specification shall be in accordance with the requirements prescribed in Tables 1 and 2, when tested by the procedures specified herein.

6. Other Requirements

6.1 The resin shall be uniform and shall contain no additives or foreign material.

6.2 The color of the material as shipped by the supplier shall be natural white.

6.3 For purposes of determining conformance, all specified limits for this classification system are absolute limits, as defined in Practice E 29.

6.3.1 With the absolute method, an observed value is not rounded, but is to be compared directly with the limiting value. Example: In Table 1 Type 4, Class B, under Specific Gravity, 2.14 ~~should~~ shall be considered as 2.140000 and 2.16 ~~should~~ shall be considered 2.160000.

7. Sampling

~~7.1 The resin~~

~~7.1 Sampling shall be sampled in accordance with an statistically adequate statistical sampling program. Adequate statistical sampling prior to packaging shall be considered an acceptable alternative.~~

~~7.2 The producer shall take (and test) sufficient within-lot samples to ensure adequate in-process quality control and continuing conformance to satisfy the property requirements of this specification in Section 11.~~

8. Number of Tests

8.1 Lot inspection shall include tests for bulk density, particle size, and extrusion pressure. Periodic tests shall consist of all the tests specified in Tables 1 and 2 and shall be made at least once per year.

8.2 The tests listed in Tables 1 and 2, as they apply, are sufficient to establish conformity of a material to this specification. One set of test specimens as prescribed in Section 3 shall be considered sufficient for testing each sample. The average of the results for the specimens tested shall conform to the requirements of this specification.

9. Specimen Preparation

9.1 *Test Disks for Tensile Properties* :

9.1.1 Use the die shown in Fig. 1 for the molding of test disks (see Note 2). Place flat aluminum disks, 0.1 to 0.4 mm ~~(0.004 in. to 0.016 in.)~~ thick and 76 mm ~~(3 in.)~~ [3 in.] in diameter, on both sides of the resin. The test resin ~~should~~ shall be near ambient temperature prior to molding (see Note 4) ~~(3)~~. **Warning**—PTFE resins can evolve small quantities of gaseous products when heated above 204°C [400°F]. Some of these gases are harmful. Consequently, exhaust ventilation must be used whenever these resins are heated above this temperature, as they are during the sintering operations that are a part of this specification. Since the temperature of burning tobacco exceeds 204°C [400°F], those working with PTFE resins shall ensure that tobacco is not contaminated.

~~NOTE 3—Caution: PTFE resins can evolve small quantities of gaseous products when heated above 204°C (400°F). Some of~~ 3—For maximum precision, these gases are harmful. Consequently, exhaust ventilation must weighing and preforming operations shall be used whenever these resins are heated above carried out at 23 ± 2°C [73.4 ± 3.6°F] (the “near ambient” temperature referred to herein). These operations shall not be performed at temperatures below 21°C [70°F] due to the crystalline transition that occurs in PTFE in this temperature region which leads to possible cracks in sintered specimens and differences in specimen density (as well as they are during changes in other physical properties). Problems caused by the sintering

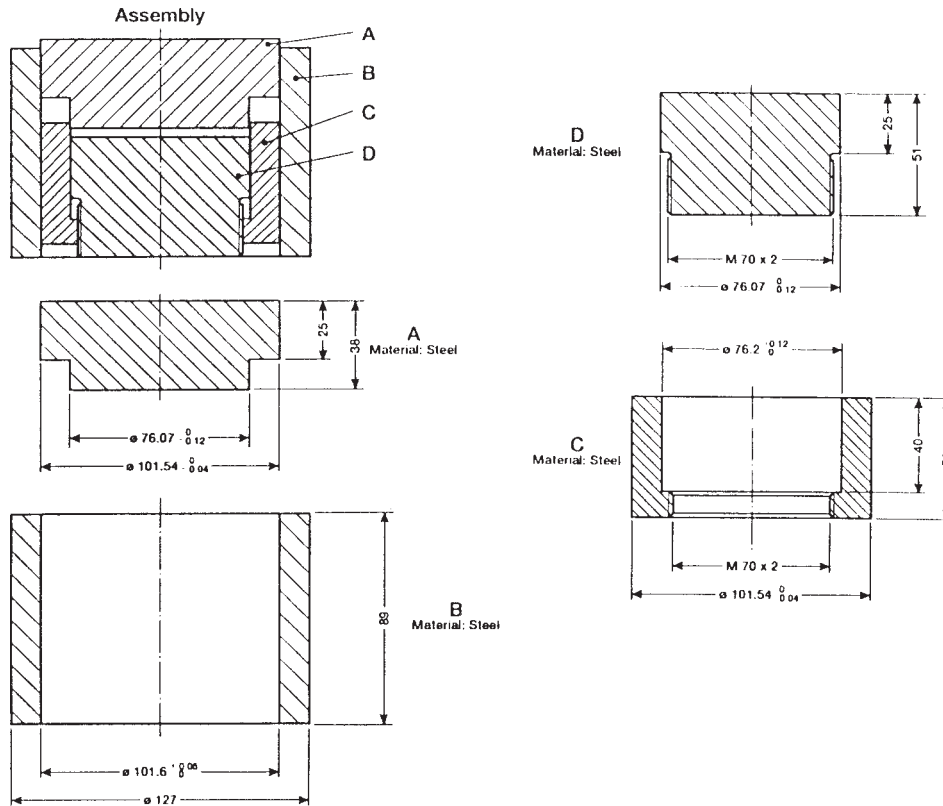

NOTE—All dimensions are in millimetres.

FIG. 1 Mold Assembly for the Preparation of Specimens for the Determination of Tensile Properties

operations that are a part effect of this specification. Since temperature on the specific gravity or density of PTFE shall be minimized when the measurement is made using immersion procedures if a sensitive thermometer (for example, one reading $\pm 0.1^\circ\text{C}$) is used in the liquid and the temperature is adjusted to be at least 22°C .

9.1.2 Screen 14.5 g of burning tobacco exceeds 204°C (400°F), those working with PTFE resin through a No. 10 sieve into the die. Adjust the lower plug height to allow the resin in the die can be leveled by drawing a straightedge in contact with the top of the die across the top of the die cavity. Insert the die in a suitable hydraulic press and apply pressure gradually (see Note 4) until a pressure of 14 MPa [2030 psi] is attained. Hold this pressure for 3 min. Remove the disk from the die. Write the sample identification number on the preform using an appropriate marker that will not contaminated. effect the PTFE during sintering.

NOTE 4—For maximum precision, these weighing and preforming operations should be carried out at $23 \pm 2^\circ\text{C}$ ($73.4 \pm 3.6^\circ\text{F}$) (the “near ambient” temperature referred to herein). These operations should not be performed at temperatures below about 21°C (70°F) due to the crystalline transition that occurs in PTFE in this temperature region which leads to possible cracks in sintered specimens and differences in specimen density (as well as changes in other physical properties). Problems caused by the effect of temperature on the specific gravity or density of PTFE can be minimized when the measurement is made using immersion procedures if 4—As a sensitive thermometer (for example, one reading $\pm 0.1^\circ\text{C}$) is used in the liquid and the temperature is adjusted to be at least 22°C .

9.1.2 Screen 14.5 g of PTFE resin through a No. 10 sieve into the die. Adjust the lower plug height so that the resin in the die can be leveled by drawing a straightedge in contact with the top of the die across the top of the die cavity. Insert the die in a suitable hydraulic press and apply pressure gradually (see Note 5) until a pressure of 14 MPa (2030 psi) is attained. Hold this pressure for 3 min. Remove the disk from the die. A wax pencil may be used to write the sample identification on the disk at this time.

NOTE 5—As a guide, increasing the pressure at a rate of 3.5 MPa ([500 psi])/min is suggested until the desired maximum pressure is attained.

9.1.3 Place the sintering oven in a laboratory hood (or equip it with an adequate exhaust system) and sinter the preforms in accordance with Table 3, Procedure A (see Note 6–5).

NOTE 65—Although the rate of heat application is not critical, the cooling cycle is most important and the conditions cited in this procedure must be followed very closely. If they are not followed, the crystallinity of the disks and the resulting physical properties may will be markedly changed. Therefore, the use of a programmed oven is recommended for the most precise sintering cycle control so that and the hood window may shall be left down during the entire sintering procedure, the latter being an important safety consideration.

9.2 Test Specimens for Standard Specific Gravity and Thermal Instability Index:

9.2.1 A cylindrical preforming mold, 29-mm ([1.14-in.]) internal diameter by at least 76 mm (3 in.) [3 in.] deep, is used to prepare the preforms. Clearance should shall be sufficient to ensure escape of air during pressing. Place flat aluminum foil disks,

TABLE 3 Sintering Procedures

	A	B
Initial temperature, °C (°F)	290 (554)	290 (554)
Initial temperature, °C [°F]	290 [554]	290 [554]
Rate of heating, °C/h (°F/h)	120 ± 10	120 ± 10
Rate of heating, °C/h [°F/h]	120 ± 10 (216 ± 18) [216 ± 18]	120 ± 10 (216 ± 18) [216 ± 18]
Hold temperature, °C (°F)	380 ± 6	380 ± 6
Hold temperature, °C [°F]	380 ± 6 (716 ± 10) [716 ± 10]	380 ± 6 (716 ± 10) [716 ± 10]
Hold time, min	30 + 2, -0	360 ± 5
Cooling rate, °C/h (°F/h)	60 ± 5	60 ± 5
Cooling rate, °C/h [°F/h]	60 ± 5 (408 ± 9) [108 ± 9]	60 ± 5 (408 ± 9) [108 ± 9]
Second hold temperature, °C (°F)	294 ± 6	294 ± 6
Second hold temperature, °C [°F]	294 ± 6 (561 ± 10) [561 ± 10]	294 ± 6 (561 ± 10) [561 ± 10]
Second hold time, min	24 + 0.5, -0	24 + 0.5, -0
Period to room temperature, min	≥30	≥30

normally 0.13 mm (0.005 in.) thick and 29 mm (1.14 in.) in diameter on both sides of the resin. The test resin ~~should~~ shall be near ambient temperature prior to molding (see Note 4-3).

9.2.2 Weigh out 12.0 ± 0.1 g of resin and place it in the die. Screen non-freeflowing resins through a No. 10 sieve. Compacted resins ~~can~~ shall be broken up by hand-shaking cold resin in a half-filled sealed glass container. Condition the resin in the sealed glass container in a freezer or dry-ice chest. After breaking up resin lumps, allow the sealed container to equilibrate to near ambient temperature. Then screen and weigh the 12.0 ± 0.1 -g sample. Insert the die in a suitable hydraulic press and apply pressure gradually (see Note 5-4) until a pressure of 14 MPa (2030 psi) is attained. Hold this pressure for 2 min. Remove the preform from the die. ~~A wax pencil may be used to write~~ Write the sample identification number on the preform using an appropriate marker that will not effect the PTFE during sintering.

9.2.3 Sinter the preforms in accordance with Table 3 (see Note 6-5).

9.2.3.1 For SSG specimens use Procedure A.

9.2.3.2 For ESG specimens use Procedure B.

NOTE 7-6—Improved precision in SSG and ESG test results has been obtained with the use of an upright, cylindrical oven and an aluminum sintering rack. The cylindrical oven has an inside diameter of 140 mm (5.5 in.) and an inside depth of 203 mm (8 in.) [8 in.] plus additional depth to accommodate a 51-mm (2 in.) [2 in.] thick cover, and is equipped with suitable heaters and controllers to sinter specimens in accordance with the procedures in Table 3. The rack, as shown in Fig. 2, allows preforms to be placed symmetrically in the center region of the oven. Place six preforms on each of the middle oven rack shelves (if six or fewer preforms are to be sintered, place them on the middle rack, filling in with “dummies” as needed). Place “dummies” on the top and bottom shelves. Specimens must be spaced evenly in a circle on each shelf, with none of them touching. An oven load must be no less than 18 pieces including “dummies.” “Dummies” are defined as normal 12-g specimens that have previously been through the sintering cycle. “Dummies” must only be used for an additional two or three thermal cycles, due to eventual loss of thermal stability and physical form.

9.2.4 Remove all flash from each specimen so that no air bubbles will cling to the edges when the specimen is immersed in the solution for weighing during the standard specific gravity and thermal instability index tests. It is recommended for this section and during testing that cotton gloves be worn while handling test specimens.

9.3 *Test Disks for Stretching Void Index (SVI):*

9.3.1 Mold the disk as in 9.1.1.

9.3.2 Screen 29 g of PTFE resin through a 2.00-mm (No. 10) sieve into the die. Adjust the lower plug ~~so that to allow~~ the resin can to be leveled by drawing a straightedge in contact with the top of the die across the top of the die cavity. Insert the die in a suitable hydraulic press and apply pressure gradually (see Note 5-4) until a pressure of 7 MPa (1015 psi) is attained. Hold this pressure for 2 min, then increase the pressure to 14 MPa (2030 psi) and hold for an additional 2 min. Remove the disk from the die. ~~A wax pencil may be used to write~~ Write the sample identification number on the ~~disk at this time. preform using an appropriate marker that will not effect the PTFE during sintering.~~

9.3.3 Sinter the preforms in accordance with Table 3, Procedure A (see Note 6-5).

9.3.4 Remove all flash from those portions of these specimens that will be used for determination of specific gravities so that no air bubbles will cling to their edges when the specimens are immersed in liquid during these tests. It is recommended that cotton gloves be worn while handling test specimens.

9.4 *Conditioning Test Specimens :*

9.4.1 For tests of tensile properties and all tests requiring the measurement of specific gravities, condition the test specimens in general accordance with Procedure A of Practice D 618, with the following deviations therefrom: (1) the aging period shall be a minimum of 4 h immediately prior to testing, (2) the laboratory temperature shall be $23 \pm 2^\circ\text{C}$ (73.4 ± 3.6°F), and (3) there shall be no requirement respecting humidity. The other tests require no conditioning of the molded test specimens.

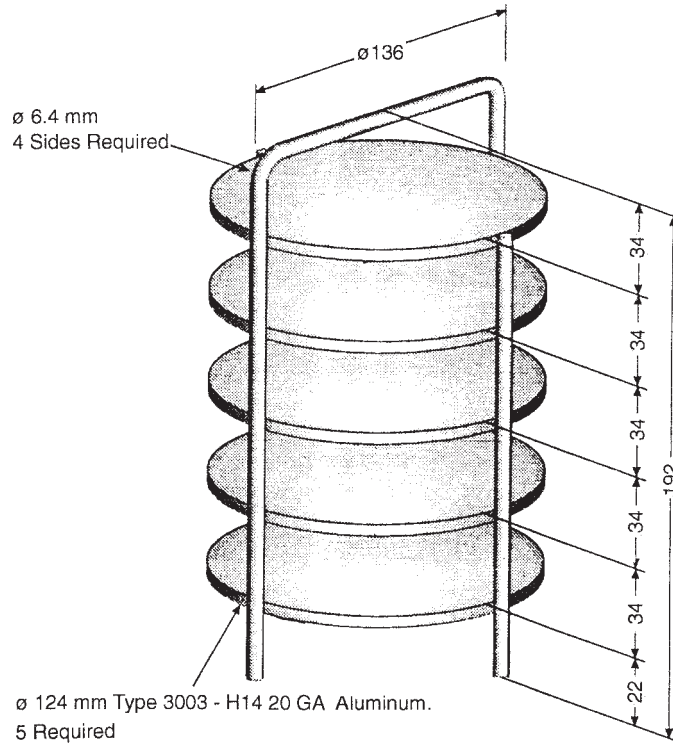

NOTE 1—Aluminum plates tack welded to rods.

NOTE 2—All dimensions are in millimetres.

FIG. 2 Sintering Rack for SSG Specimens

9.5 Test Conditions:

9.5.1 Tests shall be conducted at the standard laboratory temperature of $23 \pm 2^\circ\text{C}$ ($[73.4 \pm 3.6^\circ\text{F}]$), unless otherwise specified in the test methods or in this specification. This deviation from the standard laboratory temperature is made because of the necessity for maintaining test temperatures above approximately 21°C (70°F); $[70^\circ\text{F}]$. See Note 4.3 for additional details. Since these resins do not absorb water, the maintenance of constant humidity during testing is not required.

10. Test Methods

10.1 Melting Characteristics by Thermal Analysis:

10.1.1 Significance and Use—For PTFE resins that have been melted prior to use, the melting peak temperature characteristics of a resin provide important information about the thermal history of the material. Melting peak temperatures (see Fig. 3) are used

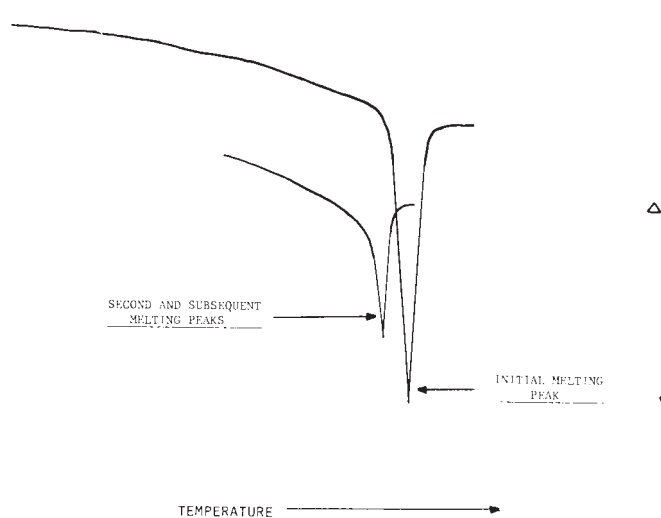

FIG. 3 Melting Characteristics by Thermal Analysis

to determine conformance of a resin to the melting peak temperature requirements in Table 1 of this specification.

10.1.2 *Apparatus*—Use apparatus described in Test Method D 4591.

10.1.3 *Procedure*—Measure melting peak temperatures in accordance with procedures given in Test Method D 4591. An initial melting peak temperature above the melting peak temperature obtained on the second and subsequent melting (defined as the second melting peak temperature) indicates that the resin was not melted before the test. The second melting peak temperature occurs at about 327°C (621°F). The difference between the initial and second melting peak temperatures is greater than 5°C (9°F). If peak temperatures are difficult to discern from the curves (that is, because the peaks are rounded rather than pointed) straight lines should be drawn tangent to the sides of the peak. ~~Where these~~ These lines intersect ~~should be taken as~~ at the peak temperature. ~~Multiple peaks during the initial melting test may occur.~~ Where more than one peak occurs during the initial melting test, the presence of any peak corresponding to the second melting peak temperature ~~may indicate~~ indicates the presence of some previously melted material.

10.2 *Bulk Density*:

10.2.1 *Significance and Use*—Bulk density gives an indication of how a resin may perform during the filling of processing equipment. PTFE resins tend to compact during shipment and storage, and even though the material may be broken up by screening or some other means, original “as produced” results may not be duplicated. Because of this tendency to pack under small amounts of compression or shear, Test Method D 1895 is not applicable to these resins. The procedure given in 10.2.2 through 10.2.5 must be used to measure this property.

10.2.2 *Apparatus*:

10.2.2.1 *Funnel*—A funnel arrangement as shown in Fig. 4.

10.2.2.2 *Feeder*⁶—A feeder with a No. 8 wire screen placed over approximately the top two thirds of the trough. The funnel shall be mounted permanently in the feeder outlet.

Annual Book of ASTM Standards, Vol 08.03.

⁶ A “Vibra-Flow” Feeder, Type FT01A, available from FMC Corp., Material Handling Division, FMC Building, Homer City, PA 15748, has been found satisfactory for this purpose.

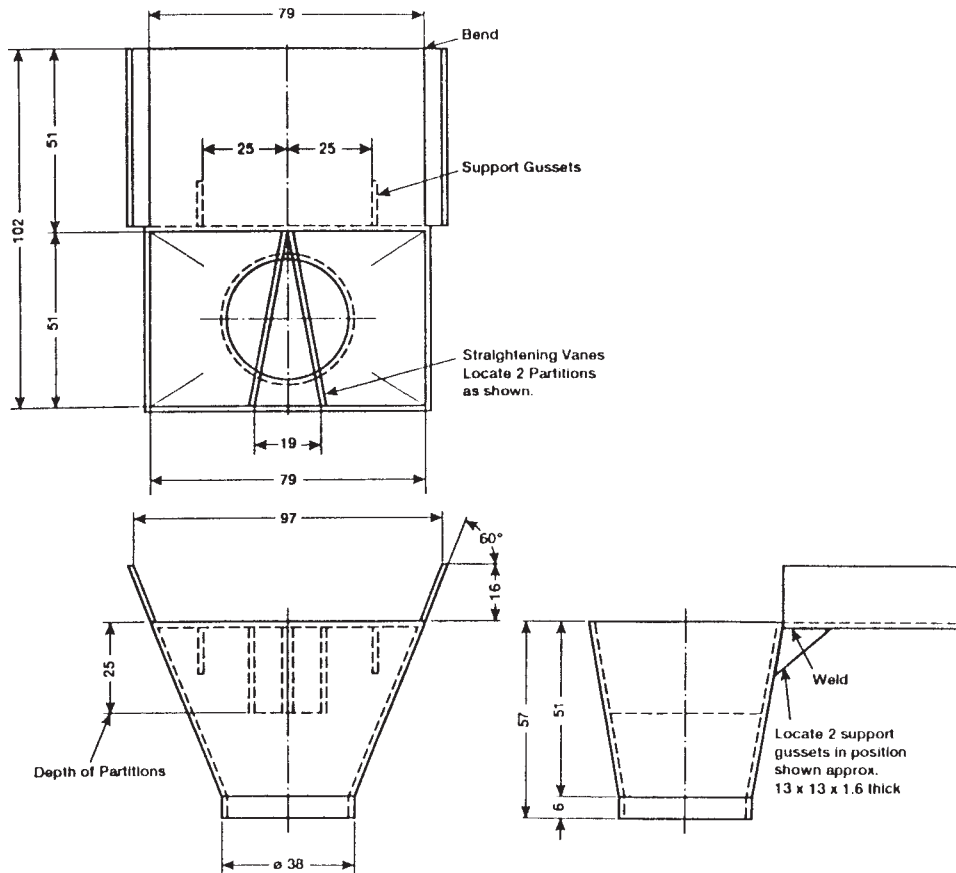

NOTE 1—Funnel Material: type 304 Stainless Steel 16 Gage (1.6-mm thickness).

NOTE 2—All dimensions are in millimetres.

FIG. 4 Details of the Funnel Used for the Determination of Bulk Density

10.2.2.3 *Controller*.⁷

10.2.2.4 *Volumetric Cup and Cup Stand* (see Fig. 5)—The volumetric cup shall be calibrated initially to 250 mL by filling it with distilled water, placing a planar glass plate on top, drying the outside of the cup, and weighing. The net weight shall be 250 ± 0.5 g. The top and bottom faces of the volumetric cup and the cup stand shall be machined plane and parallel.

10.2.2.5 *Leveling Device*— The leveler (see Fig. 6) shall be affixed permanently to the table and adjusted so that the sawtooth edge of the leveler blade passes within 0.8 mm (0.031 in.) of the top of the volumetric cup.

10.2.2.6 *Work Surface*— The work surface for holding the volumetric cup and leveler shall be essentially free from vibration. The feeder, therefore, must be mounted on an adjoining table or wall bracket.

10.2.2.7 *Balance*—Balance, having an extended beam, with a capacity of 500 g and a sensitivity of 0.1 g, or equivalent.

10.2.3 *Procedure*—Place the clean, dry volumetric cup on the extended beam of the balance and adjust the tare to zero. Select about 500 mL of the resin to be tested and place it on the feeder screen. Put the cup in the cup stand and place the assembly such that the distance of free-polymer fall from the feeder outlet to the top rim of the cup shall be 39 ± 3 mm (1.5 ± 0.012 in.). Increased fall causes packing in the cup and higher bulk density values. Set the controller so that the cup is filled in 20 to 30 s. Pour the sample on the vibrating screen and fill the cup so that the resin forms a mound and overflows. Let the resin settle for about 15 s and then gently push the cup and its stand beneath the leveler. Exercise care to avoid agitation of the resin and cup before leveling. Weigh the resin to the nearest 0.1 g.

10.2.4 *Calculation*— Calculate the bulk density as follows:

$$\text{grams of resin} \times 4 = \text{bulk density(grams per litre)}$$

10.2.5 *Precision and Bias*—A precision statement for use with this procedure is under development. The procedure in this test method has no bias because the value of bulk density can shall be defined only in terms of a test method.

10.3 *Particle Size:*

10.3.1 *Significance and Use*—The fabrication of PTFE resins ~~may be~~ is affected significantly by particle (or agglomerate) size and size distribution. The average particle size of PTFE resins is determined by fractionation of the material with a series of sieves. Fractionation is accomplished by mechanically shaking the material in the assembly of sieves for a specified period.

10.3.2 *Apparatus:*

Annual Book of ASTM Standards, Vol 14.02.

⁷ A "Syntron" controller, Type SCR1B, available from FMC Corp., address as shown in Footnote 10, has been found satisfactory for this purpose.

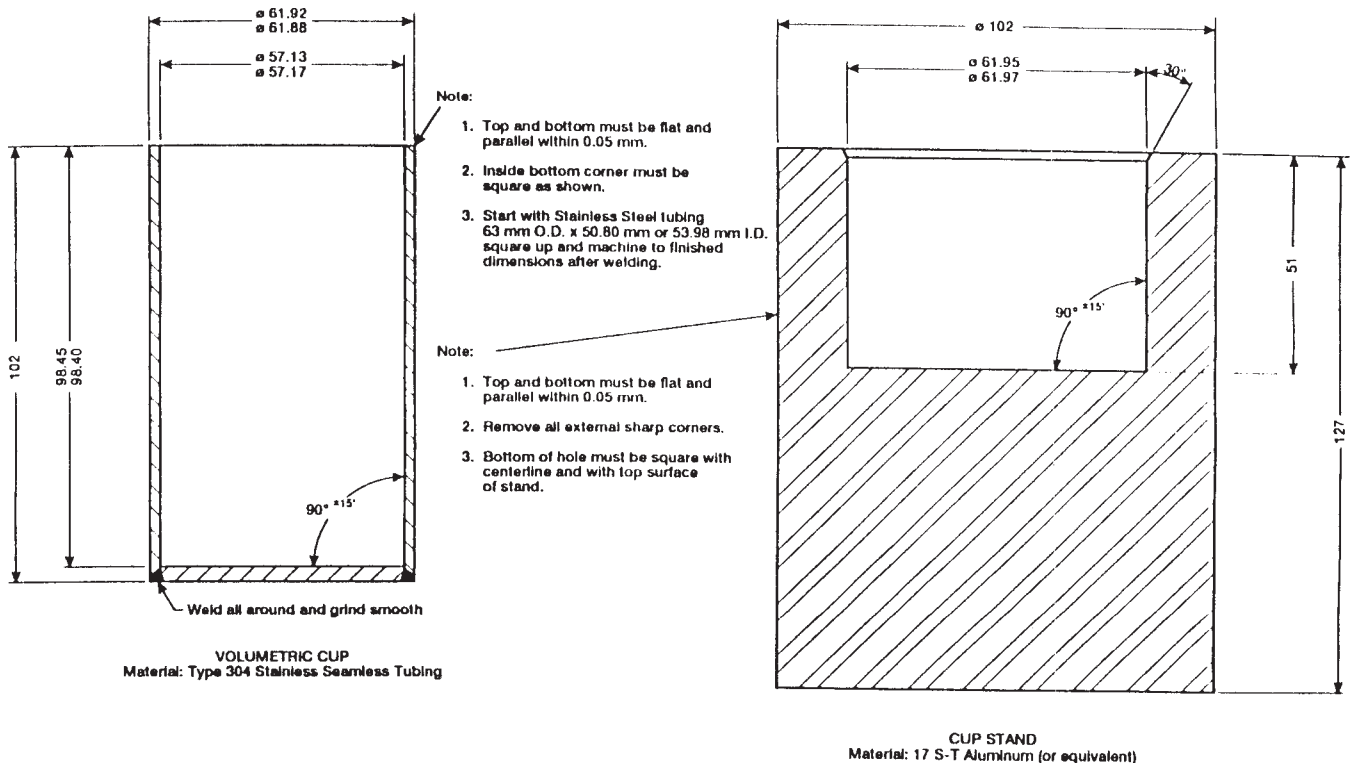

NOTE—All dimensions are in millimetres.

FIG. 5 Volumetric Cup and Cup Stand for the Determination of Bulk Density

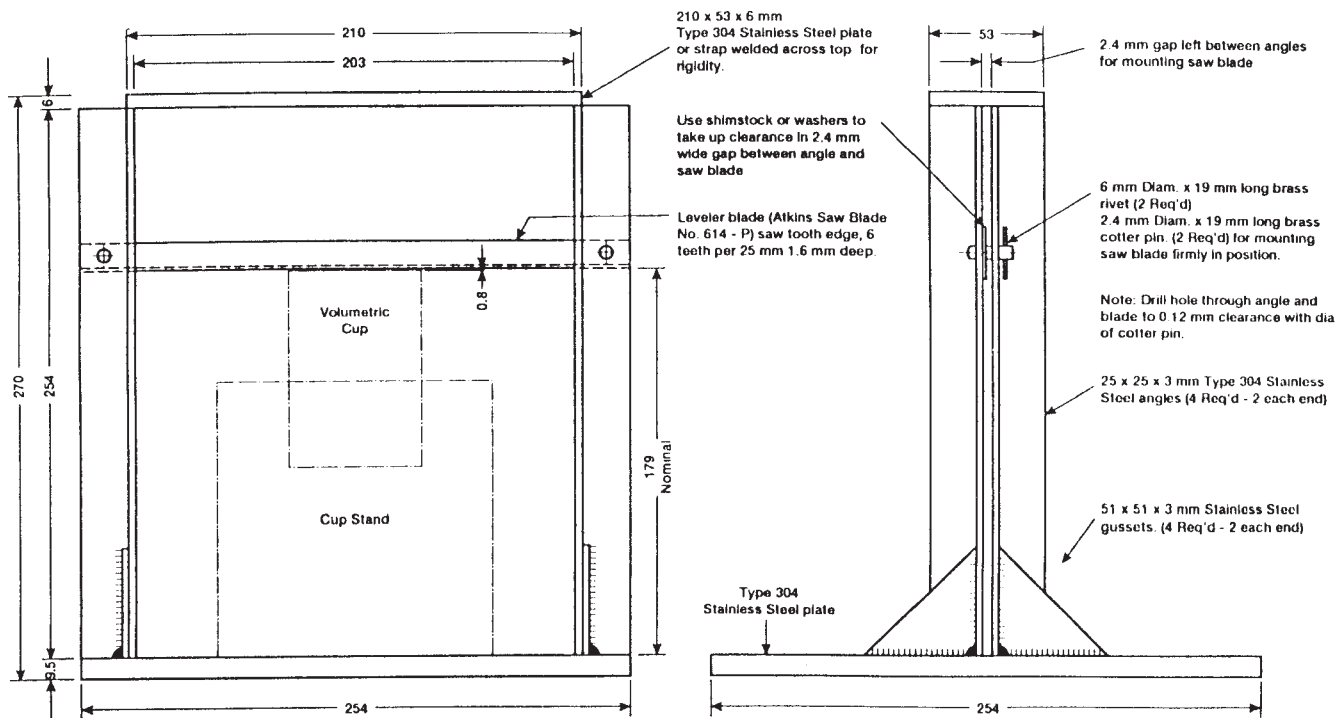

NOTE 1—Base plate must be flat and parallel. Saw blade, when mounted, must be square to and parallel with base plate within 0.13 mm from end to end. Height of saw blade must have 0.8 mm or less clearance between blade and assembled cup and cup stand (as indicated by phantom lines). Welded construction where indicated. Material: as noted.

NOTE 2—All dimensions are in millimetres.

FIG. 6 Leveler Stand for the Determination of Bulk Density

10.3.2.1 *Balance*, capable of weighing to ± 0.1 g.

10.3.2.2 *Sieves*, U.S. Standard Sieve Series, 203-mm-(8-in.) [8-in.] diameter conforming to Specification E 11. It is suggested that the following sieve numbers (openings) be used: 1.40 mm (14), 1.00 mm (18), 710 μm (25), 500 μm (35), 355 μm (45), 250 μm (60), and 180 μm (80). However, other configurations of sieves may be used to give equivalent results.

10.3.2.3 *Sieve Shaker*—A mechanical sieve shaking device capable of imparting uniform rotary and tapping action.

10.3.2.4 *Freezer*—Any commercial ice freezer. (A dry-ice chest may be used.)

10.3.3 *Procedure*:

10.3.3.1 Place 50 ± 0.1 g of the sample in an aluminum pan, and cool the pan and contents to less than 10°C (50°F), [50°F].

10.3.3.2 Measure the tare weight of each of the sieves listed in 10.3.2.2. Place the conditioned sample on the top sieve of the assembly and shake in the sieve shaker for 10 ± 0.5 min. The dewpoint temperature of the sieving room must be less than the temperature of the conditioned sample so that water will not condense on the sample during this test. Determine the weight of resin retained on each sieve.

10.3.4 *Calculation*:

10.3.4.1 Calculate the net percentage of resin on each sieve as follows:

$$\text{net percentage on sieve } Y = 2 \times \text{weight of resin in grams on sieve } Y.$$

10.3.4.2 Calculate the cumulative percentage of resin on each sieve as follows:

$$\text{cumulative percentage on sieve } Y = \text{sum of net percentages on sieve } Y \text{ and sieves having numbers smaller than } Y.$$

NOTE 87—Cumulative percentage on 500- μm (No. 35) sieve = net percentage on 1.40-mm (No. 14) + net percentage on 1.00-mm (No. 18) + net percentage on 710- μm (No. 25) + net percentage on 500- μm (No. 35) sieves.

10.3.4.3 Plot the cumulative percentage versus the sieve opening size (or sieve number) on log-probability paper as shown in the sample plot (see Fig. 7). The sieve numbers and sieve opening sizes in micrometres are indicated below the figure. Draw the best straight line through the points and read the particle size at the 50 % cumulative percentage point (D_{50}).

10.3.4.4 Calculate the particle size, average diameter, d_{50} , as follows:

$$d = d_{50}(\text{micrometres})$$

10.3.5 *Precision and Bias*—The test precision is ± 3.2 % (two sigma limits) for the combination of 710 + 500 + 355- μm (25 + 35 + 45) sieve fractions for a resin where this combination of sieves retains, on the average, 78 % of the sample. Since there

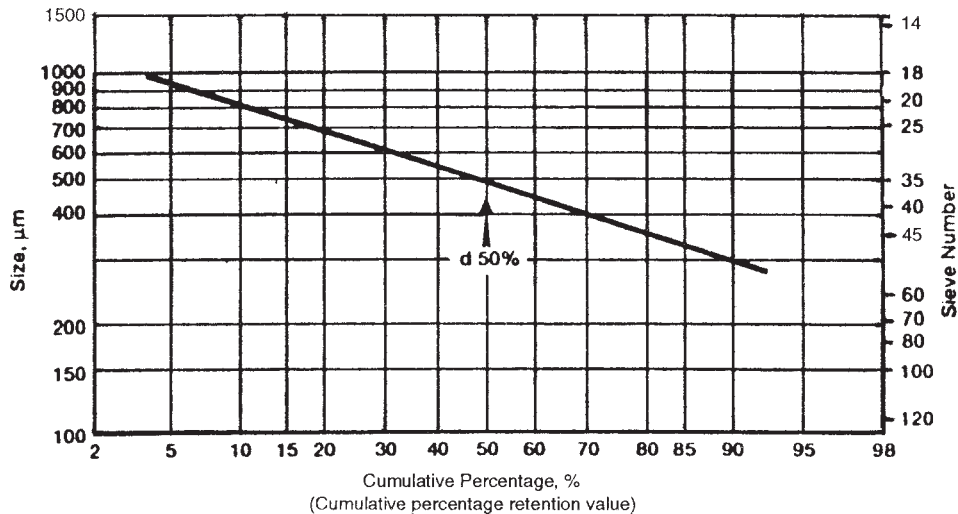

Sieve No.	Sieve Opening, µm
14	1400
18	1000
25	710
35	500
45	355
60	250
80	180

FIG. 7 Log Probability Plot for Sieve Analysis

is no accepted reference material suitable for determining the bias for this test procedure, no statement on bias is being made.

10.3.6 Alternative methods for particle size are available. Light Scattering Instruments/Light Defraction Instruments (see ISO 12086-2, 8.6.4) and Electron Zone Sensing Instruments, which is a resistance-variation tester, (see ISO 12086-2, 8.6.3) are used as long as there is a direct correlation to the Particle Size Analysis in 10.3 of this specification.

10.3.6.1 This alternative method is very dependent on particle shape and is only recommended for processes that are stable and that have regular spherical type shape particles. Also, it is recommended that each manufacturing processor do an analysis to determine their own correlation.

10.4 Water Content:

10.4.1 Significance and Use—The presence of an excessive amount of water in PTFE resin has a significant adverse effect upon the processing characteristics of the resin and the quality of products made using the resin. A sample of PTFE resin of known weight is dried in a vacuum oven in a tared aluminum weighing dish. When the resin is dry, it is removed from the oven, placed in a desiccator, allowed to cool, and then reweighed. Water content is calculated from the weight lost during drying.

NOTE 98—If volatiles other than water are suspected, use the alternative method described in 10.4.6.

10.4.2 Apparatus:

10.4.2.1 Balance, capable of weighing to the nearest 0.0001 g.

10.4.2.2 Vacuum Oven.

10.4.2.3 Aluminum Weighing Dishes, with lids.

10.4.3 Procedure (see Note 9 8)—Wash the aluminum weighing dishes with water and rinse with acetone. When the acetone has evaporated from the dishes, dry them thoroughly in an oven at 50 to 80°C ([122 to 176°F]), then store in a desiccator until ready for use. Obtain the tare weight, B, of an aluminum weighing dish, plus lid, to the nearest 0.0001 g. Place 35 to 40 g of PTFE resin in the tared aluminum weighing dish and record the weight (including lid), A, to the nearest 0.0001 g (see Note 10 9). Dry to constant weight in a vacuum oven ([635 mm (25 in.) Hg] [25 in.] Hg) at 150°C ([302°F]), with the dish lid removed. Remove the dish from the oven, replace the lid on the weighing dish, and allow to cool in the desiccator for at least 30 min. Reweigh the dish (plus the resin and lid), C, and calculate the weight loss.

NOTE 10 9—Select one sample from each group of samples and run duplicate moisture determinations on it. If the difference between the duplicate results exceeds 0.01 percentage points, the entire group of samples must be run over.

NOTE 11 0—When a group of samples is run at the same time, it is good practice to place the lids from the weighing dishes directly under their corresponding dishes while the samples are drying in the oven. This eliminates the possibility of introducing errors in the tare weights. Also, overnight drying in a circulating air oven may be used if the data can be shown to be equivalent to those obtained with the above procedure.

10.4.4 Calculation— Calculate the water content as follows:

$$\text{water content, \%} = (A - C) / (A - B) \times 100$$

where:

A = weight of resin, dish, and lid, g

B = weight of dish and lid, g, and

C = weight of resin, dish, and lid after drying, g.

10.4.5 *Precision and Bias*—The precision of this test is ± 0.0063 percentage points (two sigma limits). Since there is no accepted reference material suitable for determining the bias for this test, no statement on bias is being made.

10.4.6 *Alternative Method for Determination of Water Content by Karl Fischer Reagent:*

8

10.4.6.1 Weigh 35 ± 1 g of resin into a glass-stoppered flask containing about 50 mL of pretitrated methanol. Shake to mix with a swirling motion for a few minutes. Titrate with standardized Karl Fischer Reagent⁹ to a visual or electrometric end point.

10.5 *Standard Specific Gravity (SSG) :*

10.5.1 *Significance and Use*—The specific gravity of an article made from a PTFE resin is affected both by the particular resin used and by the way the resin is processed. Therefore, a test method that measures the specific gravity of an article prepared in a precisely defined way provides valuable resin characterization data. The specific gravity of a specimen of PTFE resin prepared in accordance with all of the requirements of 9.2.3.1 defines the SSG for that resin specimen.

10.5.2 *Procedure:*

10.5.2.1 Determine, in accordance with ~~10.5.2.2 or 10.5.2.3~~, 10.5.2.2, the specific gravity of specimens prepared in 9.2.3.1.

10.5.2.2 Make specific gravity determinations in accordance with the procedures described in Test Methods D 792, Method A. Add two drops of a wetting agent¹⁰ to the water in order to reduce the surface tension and ensure complete wetting of the specimen.

~~10.5.2.3 *Specific Gravity by Density-Gradient Technique*—When the better precision of 10.5.2.2 is not required, the density-gradient test described in Test Method D 1505 may be used.~~

10.6 *Thermal Instability Index (TII) :*

10.6.1 *Significance and Use*—The TII gives an indication of how a resin resists degradation during extended periods of heating at sintering temperatures. This test method compares the SSG of a resin (determined in 10.5) to its extended specific gravity (determined here). Specimens used to determine ESG are identical to those used to determine SSG, except for the differences in thermal history described in 9.2.3. The specific gravity of a specimen of PTFE resin prepared in accordance with all of the requirements of 9.2.3.2 defines the ESG for that resin specimen.

10.6.2 *Procedure*—Determine, in accordance with ~~10.5.2.2 or 10.5.2.3~~, 10.5.2.2, the specific gravity of specimens prepared in 9.2.3.2.

10.6.3 *Calculation*— Calculate the thermal instability index (TII) as follows:

$$TII = (ESG - SSG) \times 1000$$

10.7 *Tensile Properties:*

10.7.1 *Procedure*—Cut five tensile specimens from the disk prepared in accordance with all of the requirements of 9.1.3, using the microtensile die described in Fig. 8.¹¹ Determine the tensile strength in accordance with the procedures described in Test Method D 638, except that the initial jaw separation shall be 22.0 ± 0.13 mm ($[0.875 \pm 0.005$ in.]), and the speed of testing shall be 50 mm ($[2$ in.])/min. Clamp the specimen with essentially equal lengths in each jaw. Determine elongation at break from the chart, expressed as a percentage of the initial jaw separation.

10.7.2 *Precision and Bias*—A precision and bias statement for use with this procedure is under development and will be included when it has been approved by the balloting process.

10.8 *Extrusion Pressure:*

10.8.1 *Significance and Use*—Processing of the PTFE resins covered by this specification normally involves “paste extrusion” of a blend of the resin with a volatile liquid, as indicated in 1.1. The pressure that must be applied to such a blend to extrude it is affected by several processing conditions which include the nature and amount of deformation imparted to the blend during extrusion (usually characterized by the reduction ratio), the type and amount of liquid used, and the extrusion temperature. When such a blend is extruded under well-defined processing conditions, the pressure required to affect extrusion (extrusion pressure) provides significant characteristic information about the resin itself.

10.8.2 *Apparatus* (~~equivalent apparatus may be substituted~~): Recommended apparatus:

10.8.2.1 *Paste Extruder* (Fig. 9) —One paste extruder that ~~may be~~ is used is a vertically disposed, breech-loading extruder with a 32-mm ($[1.26$ in.]) inside diameter extrusion cylinder. The barrel length is approximately 305 mm ($[12$ in.]), which is not critical

⁸ Available from American National Standards Institute, 11 W. 42nd St., 13th Floor,

⁸ Details of this method are found in Mitchell, J., Jr. and Smith, D. M. “Aquametry,” 2nd Ed., published by Interscience Publishers, Inc., New York, NY 40036: 1977.

⁹ See the ASTM *Form and Style Manual*, available

⁹ Karl Fischer Reagent (Catalog No. So-K-3) is available from ASTM Headquarters; the Fischer Scientific Co., Pittsburgh, PA.

¹⁰ A “Vibra-Flow” Feeder, Type FT01A, available from FMC Corp., Material Handling Division, FMC Building, Homer City, PA 15748, has been found satisfactory for this purpose.

¹⁰ Examples of suitable wetting agents are “Glim” detergent, B. J. Babbitt, Inc., “Joy” detergent, Proctor and Gamble, Inc; and “Triton” X-100, Rohm and Hass Co.

¹¹ A “Syntron” controller, Type SCR1B, steel rule type of die, available from FMC Corp., address as shown in Footnote 10; Admiral Steel Rule Die, 133 Railroad Ave., Garden City Park, NY 11040, has been found satisfactory for this purpose. An international source is Stansvormenfabriek Veryloet B. V., Postbus 220, Gantelweg 15, 3350 AE Papendrecht, Holland.

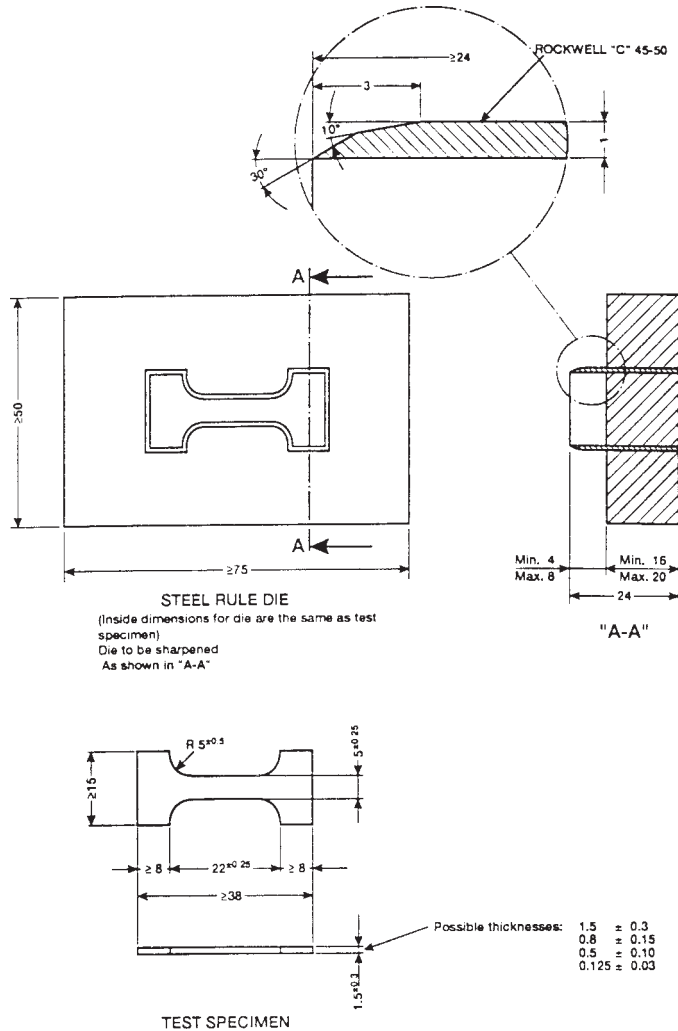

NOTE—All dimensions are in millimetres.

FIG. 8 Microtensile Die

so long as it will hold enough lubricated resin to extrude for about 5 min. The ram is 32 mm ([1.26 in.]) outside diameter, with a ring groove near its free end to hold an O-ring that makes a tight seal between the ram and extruder cylinder. The extruder is equipped with devices for sensing and recording pressure on the face of the ram. The range of the pressure sensing device shall be greater than 70 MPa ([10 000 psi]). Temperature-controlling equipment maintains the extruder at $30 \pm 1^\circ\text{C}$. A system (hydraulic or screw) drives the ram at a speed of about 18 mm/min ([0.7 in./min]) to give an output rate of 19 g/min on a dry-resin basis (about 23.5 g/min of lubricated resin) during the extrusion pressure test. The extruder also has a fast-speed drive (speed not precisely controlled) to run the ram rapidly into the cylinder cavity prior to the extrusion pressure test. The extruder-die assembly slides on tracks from under the ram to allow easy access for loading and cleaning the cylinder. An alternative muzzle-loaded paste extruder ~~may~~ shall be used which has a detachable die assembly. The die assembly is detached, a preformed charge of resin is inserted up into the cylinder and the die assembly is reattached.

10.8.2.2 *Extrusion Dies* (Fig. 10)—Interchangeable extrusion dies, each having 30° included angles, give the desired reduction ratios when dimensioned as follows:

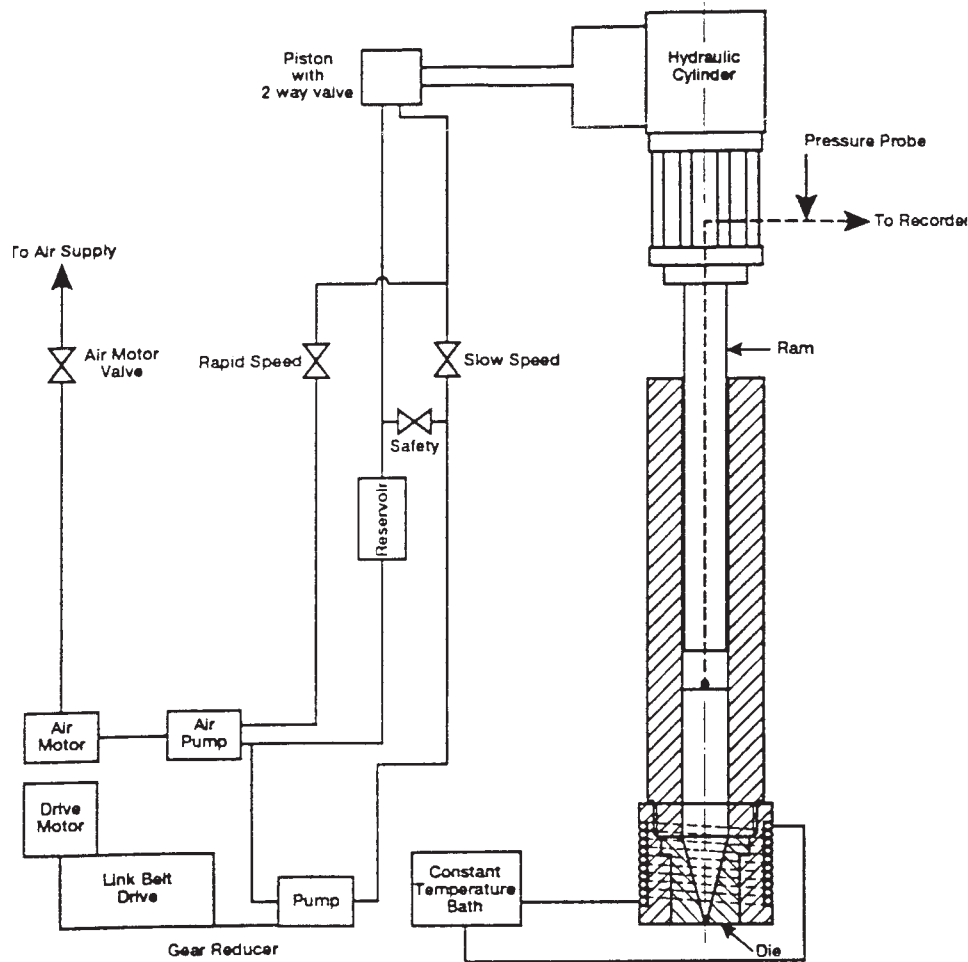

FIG. 9 Paste Extruder for Determining Extrusion Pressure

Reduction Ratio	Die Orifice (Inside Diameter), mm (in.)	Land Length, mm (in.)	Die Length, mm (in.)
400 to 1	3.18 [0.125]	25.35 [0.998]	78.66 [3.0]
400 to 1	3.18 [0.125]	25.35 [0.998]	78.66 [3.0]
400 to 1	4.78 [0.188]	4.78 [0.188]	61.06 [2.3]
400 to 1	1.59 [0.0625]	4.78 [0.188]	61.06 [2.3]
1600 to 1	0.79 [0.0312]	0.38 [0.015]	58.15 [2.2]
1600 to 1	0.79 [0.0312]	0.38 [0.015]	58.15 [2.2]

NOTE 121—Reduction ratio in this specification is the ratio of the cross-sectional area of the extruder cylinder to the cross-sectional area of the die. This must not be confused with another definition wherein reduction ratio is the ratio of the cross-sectional area of the extruder cylinder to the cross-sectional area of the sintered extrudate.

10.8.2.3 *Miscellaneous Apparatus*—Equipment is needed for weighing, blending, conditioning (at 30°C) and preforming, as well as extruded cleaning.

10.8.3 *Procedure:*

10.8.3.1 Screen the dry resin through a 4.75-mm (No. 4) sieve onto a clean, dry, lint-free sheet of paper.

10.8.3.2 Transfer 200 ± 0.5 g of the screened resin to a clean, dry glass jar about 92 mm (3.625 in.) in diameter (approximately 1-L capacity) having an airtight closure, or into a V-blender of laboratory size.

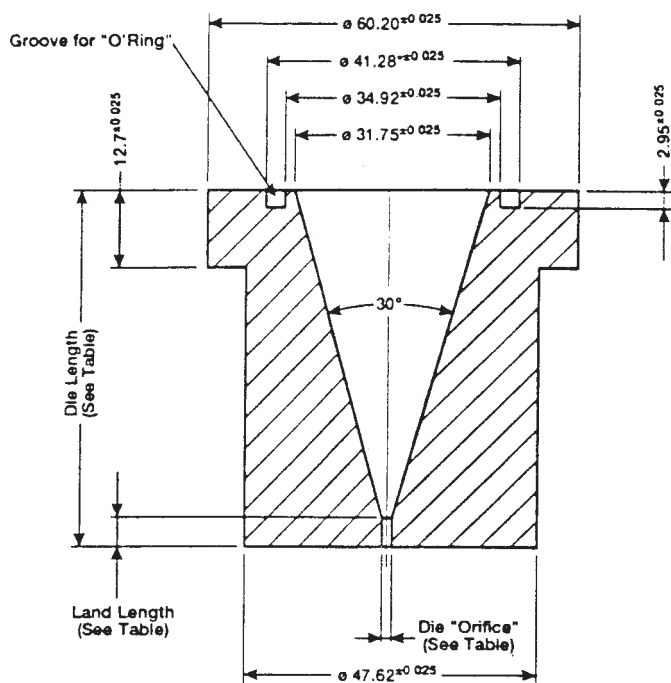
Cross sectional view
of cylindrical die.

*Depending on "O-Ring" Dimensions

Reduction Ratio	Die Orifice (Diameter)	Land Length	Die Length
100 to 1	3.18	25.35	78.66
400 to 1	1.59	4.78	61.06
1600 to 1	0.79	0.38	58.15

NOTE—All dimensions are in millimetres.

FIG. 10 Extruder Die Assembly for Extrusion Pressure Apparatus

10.8.3.3 Determine the density of the lubricant, a kerosene-type hydrocarbon liquid.¹² Determine the density at 25°C using Test Method D 4052, a commercial density meter that will give four significant figures for the density,¹³ or a technically equivalent procedure. Calculate the mass of lubricant required by multiplying the density by 60.00 mL. Add the calculated mass ± 0.01 g of the lubricant to the resin in the jar or blender. It is convenient to make this addition while the jar containing the powder is on a balance that has a sensitivity at least as good as the ± 0.01 g required for the test. Avoid wetting the walls of the blending vessel with the liquid as this impairs mixing. When a jar is used the lid ~~should~~ shall be taped in place to prevent loss of lubricant. Shake the jar briefly to minimize the wetting of the jar wall with liquid.

10.8.3.4 Blend the mixture by placing the jar on rubber-coated mill rolls and rolling it at 30 r/min for 25 ± 5 min, by fastening the jar to a windmill type blender¹⁴ and blending for 20 ± 1 min, or by blending the mixture in the V-blender for 15 ± 5 min. If a V-blender has been used, drop the resin from it into a jar of approximately 1-L capacity and seal the jar.

10.8.3.5 After blending, store the jar with its contents at $30 \pm 1^\circ\text{C}$ for a minimum of 2 h. A water bath has been found to be satisfactory. This enables the lubricant to diffuse to the interior of individual particles and surfaces not reached during the blending process.

10.8.3.6 Place the proper extrusion die for the desired reduction ratio (given in 10.8.2.2) in the paste extruder.

10.8.3.7 *Resin Preform*—To preform the resin for the breech-loading paste extruder of 10.8.2.1, slide the extruder-die assembly forward, mount a 32-mm-(1.26-in.) inside diameter extension tube about 610 mm-(24 in.) [24 in.] in length at the breech end

¹² Details of this method can be

¹² Isopar K, available from Exxon Co., has been found in Mitchell, J., Jr. and Smith, D. M. "Aquametry," 2nd Ed., published by Interscience Publishers, Inc., New York, NY 1977; satisfactory for this purpose.

¹³ Karl Fischer Reagent (Catalog No. So-K-3) is available from

¹³ A Mettler/Par DMA 40 density meter has been found suitable for determining density to the Fischer Scientific Co., Pittsburgh, PA; required precision.

¹⁴ Examples of

¹⁴ A Gilson spinning wheel mixer has been found suitable wetting agents are "Glim" detergent, B. J. Babbitt, Inc., "Joy" detergent, Proctor and Gamble, Inc; and "Triton" X-100, Rohm and Hass Co. for this purpose.

of the extruder cylinder. Quickly pour the lubricated resin through a funnel into the extension and force the resin into the extruder cylinder with a tamping rod. Apply the force with hand pressure and a very slow, even stroke. To preform the resin for the muzzle-loading paste extruder of 10.8.2.1, mount a 32-mm-([1.26-in.]) inside diameter preforming tube about 610 mm-(24 in.) in length with its cross section resting against a flat, smooth surface. Quickly pour the lubricated resin through a funnel into the tube and force the resin down in the tube. The force may be applied with a hydraulically controlled tamping device to compact the resin with a slow, even stroke to a minimum of 690 kPa-([100 psi]) on the resin. Remove the preform from the preforming tube, insert the preform up into the cylinder of the extruder, and attach the die assembly.

10.8.3.8 Use the fast-speed drive to run the ram down into the cylinder cavity. When the first bit of beading emerges from the orifice, stop the descent of the ram.

10.8.3.9 Immediately change to slow-speed drive, start the pressure-recording system, and extrude the lubricated resin at a rate of 19.0 ± 1.0 g/min (dry-resin basis).

10.8.3.10 Record the pressure developed at the face of the ram in contact with the resin in the cylinder as a function of time. The extrusion pressure is the average pressure required to extrude the sample as measured between the third and fourth minutes of the extrusion.

10.8.4 *Precision and Bias*—The test precision and bias are to be determined by round-robin testing.

10.9 *Stretching Void Index:*

10.9.1 *Significance and Use*—This test method compares the unstrained specific gravity (USG) of a resin to its strained specific gravity (strained SG). The specific gravity of a specimen of PTFE resin prepared in accordance with all of the requirements of 9.3 defines the USG for that resin specimen. The SVI gives one indication of the potential for induced void content of a solid fabricated resin product in use. Such void content may contribute to a susceptibility to the formation of cracks and failures under conditions of extreme stretching and stress or in some environments when stressed. Similar failures have also been associated, at times, with improper processing techniques.

10.9.2 *Procedure:*

10.9.2.1 Determine, in accordance with ~~10.5.2.2 or 10.5.2.3~~, 10.5.2.2, the specific gravity of specimens prepared in 9.3. This is the USG for the specimen.

10.9.2.2 Cut tensile specimens from the disk prepared in 9.3 using the microtensile die shown in Fig. 10. Clamp the specimen in a tensile testing machine with essentially equal lengths in each jaw. The initial jaw separation shall be 12.5 ± 0.1 mm-([0.5 ± 0.005 in.]). Strain the specimen at a constant rate of 5.0 mm-([0.2 in.])/min until it breaks. This strain rate and initial jaw separation yield a strain rate of 40 %/min, based on the original gage length of the specimen. If elongation at break is less than 200 %, discard the result and repeat 10.9.2.2.

10.9.2.3 Cut off a portion of the stretched part of the specimen. Determine, in accordance with ~~10.5.2.2 or 10.5.2.3~~, 10.5.2.2, the specific gravity of this strained specimen (strained SG).

10.9.3 *Calculation*— Calculate the stretching void index (SVI) as follows:

$$SVI = (USG - \text{strained SG}) \times 1000$$

11. Inspection

11.1 Inspection and certification of the material supplied with reference to this specification shall be for conformance to the requirements specified herein.

11.2 Lot-acceptance inspection shall be the basis on which acceptance or rejection of the lot is made. The lot-acceptance inspection shall consist of the following:

11.2.1 Bulk density,

11.2.2 Particle size;

~~11.2.3 Water content, size, and~~

11.2.4 3 Melting point.

11.3 Periodic check inspection with reference to a specification shall consist of the tests for all requirements of the material under the specification. Inspection frequency shall be adequate to ensure the material is certifiable in accordance with 11.4.

11.4 Certification shall be that the material was manufactured by a process in statistical control, sampled, tested and inspected in accordance with this classification system, and that the average values for the lot meet the requirements of the specification (line callout).

11.5 A report of test results shall be furnished when requested. The report shall consist of results of the lot-acceptance inspection for the shipment and the results of the most recent periodic-check inspection.

12. Rejection and Rehearing

~~12.1 Material that fails to conform to the requirements of this specification may be rejected. Rejection should be reported to the producer or supplier promptly and in writing. In case of dissatisfaction with the results of the test, the producer or supplier may make claim for a rehearing.~~

13. Packaging and Package Marking

~~13.1 Packaging~~—The resin shall be packaged in standard commercial containers so constructed as to ensure acceptance by

common or other carriers for safe transportation to the point of delivery, unless otherwise specified in the contract or order.

132.2 *Package Marking*— Shipping containers shall be marked with the name of the resin, type, and quantity contained therein.

132.3 All packing, packaging, and marking provisions of Practice D 3892 shall apply to this specification.

143. Keywords

143.1 coagulated dispersion polytetrafluoroethylene; fluoropolymers; polytetrafluoroethylene; PTFE

SUPPLEMENTARY REQUIREMENTS

The following supplementary requirements shall apply only when specified by the purchaser in the contract or order.

S1. *Ordering Information*—The purchase order should state this ASTM designation and year of issue, and which type, grade, and class is desired.

APPENDIX

(Nonmandatory Information)

X1. EXPANSION TEST FOR EXTRUDED TUBING

X1.1 Significance and Use

X1.1.1 Processing of the PTFE resins covered by this specification almost always includes extrusion of a blend of the resin with a volatile liquid. The quality of the extrudate is affected by several processing conditions which include the nature and amount of deformation imparted during extrusion, the type of resin, the type and amount of liquid used, and the extrusion temperature. When the blend is extruded into a tube under well-defined processing conditions, characterization of the resultant tube using suitable test procedures provides significant characteristic information about the resin.

X1.2 Apparatus

X1.2.1 Use the extruder shown in Fig. 8 and described in 10.8.2.1 (or equivalent apparatus), except that a guide tube which extends through the center of the ram and into the die is attached to the hydraulic cylinder and a mandrel tip is screwed onto this guide tube. The guide tube has an outside diameter of 15 mm (0.59 in.), and the mandrel tip has an outside diameter of 0.4 mm (0.016 in.) over a land length of 0.4 mm. When used in combination with the 0.8-mm (0.031-in.) orifice given in 10.8.2.2, a reduction ratio of 1600 to 1 is produced. This setup will yield a sintered tube with an outside diameter of about 0.76 mm (0.03 in.), and an inside diameter of about 0.4 mm.

X1.2.2 Use the miscellaneous apparatus described in 10.8.2.3.

X1.3 Procedure

X1.3.1 The procedure is as given in 10.8.3, except that preforming is done in a separate mold shell having a 31.6-mm (1.245-in.) inside diameter, and fitted with a central die rod having the same diameter as the extruder guide tube and suitable end plugs. Pour the lubricated resin into one end of the vertical preform mold, and tap the side of the mold shell to level the resin. Place the top mold plug in the mold, and apply a minimum pressure of 690 kPa (100 psi) to the resin.

X1.3.2 Remove the preform from the mold and wrap in aluminum foil for 4 h. This is to provide uniform distribution of lubricant within the preform.

X1.3.3 When the extruder is ready for extrusion, unwrap the preform and quickly insert it into the extruder cylinder over the guide tube. Attach the mandrel tip to the guide tube, then close the extruder cylinder and attach the die assembly.

X1.3.4 Proceed in accordance with 10.8.3.8 and 10.8.3.9. Pass the extruded tubing vertically downward through an electrically heated air oven designed to produce a higher temperature in the lower half of the oven than in the upper half. The lubricant should be is vaporized in the upper half of the oven at about 120 to 150°C (248 to 302°F). Adjust the temperature in the lower half of the oven so that the tubing passing through it is in the gel (completely transparent) for about 100 mm (4 in.) [4 in.]. As the tubing emerges from the oven it is allowed to cool in air, and is then coiled on a suitable spool.

X1.3.5 Connect one end of the extruded tubing to a source of nitrogen that can shall apply at least 345-kPa (50-psi) internal pressure to the tubing. Make sure that there is at least 15 m (50-ft) [50 ft] of tubing. Clamp the free end of the tubing and push it through a heated glass tube having an inside diameter of 1.65 mm (0.065 in.). Apply 345-kPa pressure to the PTFE tubing, and move the PTFE tubing through the heated glass tube at a rate that allows the PTFE tubing to reach 340°C (644°F) [644°F] in the last 75 to 100 mm (3 to 4 in.) of the glass tube (that is, the PTFE tubing becomes transparent). As the PTFE tubing

becomes transparent it ~~should expand~~ expands against the inner surface of the glass tube. If this does not occur, increase the nitrogen pressure slowly until expansion occurs.

X1.3.6 As the expanded tubing emerges from the glass tube allow it to cool in air and coil it up on a suitable spool. If a flaw appears and the expanded tubing loses nitrogen pressure, clamp off the tubing downstream of the flaw and continue.

X1.3.7 The expanded tubing is inspected visually for flaws and stretch marks.

NOTE X1.1—This test is not appropriate for all resins.

SUMMARY OF CHANGES

Since

This section identifies the last issue, Committee D-20 has identified the location of selected changes to this specification. For the convenience of the user, Committee D20 has highlighted those changes that may impact the use of this specification. This section also includes descriptions of the changes or reasons for the changes, or both.

D 4895 – 04:

(1) Changed the text of 1.2.

(2) Deleted D 638M, E 380 and D 1505.

(3) Added D 638 and IEEE/ASTM SI 10 to 2.1

(4) Changed “may” to “shall” in 4.2, 9.1.2, Note 6, 9.2.2, 9.3.2, 10.1.3, 10.8.2, 10.8.2.1.

(5) Changed “can” to “shall” in 4.2, Note 4, 9.2.2, 9.3.2, 10.2.5, Footnote 12, X1.3.5.

(6) Changed “should” to “shall” in 4.2, 9.1.1, Note 3, Note 4, 9.2.1, 10.1.3, 10.8.3.3, X1.3.4.

(7) Changed “may be” to “is” in 10.3.1.

(8) Deleted text in 7.1 and replaced with: “Sampling shall be statistically adequate to satisfy the requirements in Section 11.”

(9) Deleted 7.2.

(10) Added 10.3.6 and 10.3.6.1.

(11) Deleted 10.5.2.3.

(12) Deleted 11.2.3: “Water Content.”

(13) Deleted second sentence in 11.3: “Inspection frequency shall be...”

(14) Deleted 11.4.

(15) Deleted “Rejection and Rehearing” section.

D 4895 – 98:

(1) Added reference to Practice E 29 to 2.1.

(2) Changed the definition of *lot* in 3.2.3.

(3) Added 6.3 and 6.3.1 to clarify the use of test data and specification data in this test method.

(4) Deleted reference to Practice D 1898 in 7.1 and replaced with appropriate wording to conform to Guide D 5740.

(5) Added new Sections 11.1 through 11.4 to conform to Guide D 5740.

ASTM International takes no position respecting the validity of any patent rights asserted in connection with any item mentioned in this standard. Users of this standard are expressly advised that determination of the validity of any such patent rights, and the risk of infringement of such rights, are entirely their own responsibility.

This standard is subject to revision at any time by the responsible technical committee and must be reviewed every five years and if not revised, either reapproved or withdrawn. Your comments are invited either for revision of this standard or for additional standards and should be addressed to ASTM International Headquarters. Your comments will receive careful consideration at a meeting of the responsible technical committee, which you may attend. If you feel that your comments have not received a fair hearing you should make your views known to the ASTM Committee on Standards, at the address shown below.

This standard is copyrighted by ASTM International, 100 Barr Harbor Drive, PO Box C700, West Conshohocken, PA 19428-2959, United States. Individual reprints (single or multiple copies) of this standard may be obtained by contacting ASTM at the above address or at 610-832-9585 (phone), 610-832-9555 (fax), or service@astm.org (e-mail); or through the ASTM website (www.astm.org).