



# Standard Test Method for Horizontal Burning Characteristics of Cellular Polymeric Materials<sup>1</sup>

This standard is issued under the fixed designation D 4986; the number immediately following the designation indicates the year of original adoption or, in the case of revision, the year of last revision. A number in parentheses indicates the year of last reapproval. A superscript epsilon ( $\epsilon$ ) indicates an editorial change since the last revision or reapproval.

## 1. Scope\*

1.1 This fire-test-response test method describes a small-scale horizontally oriented burning test procedure for comparing the relative rate of burning and the extent and time of burning of cellular polymeric materials having a density less than 250 kg/m<sup>3</sup>.

1.2 The classification system described in the Appendix X1 is intended for quality assurance and the preselection of component materials for products.

1.3 *This standard measures and describes the response of materials, products, or assemblies to heat and flame under controlled conditions, but does not by itself incorporate all factors required for fire hazard or fire risk assessment of the materials, products, or assemblies under actual fire conditions.*

1.4 *This standard does not purport to address all of the safety concerns, if any, associated with its use. It is the responsibility of the user of this standard to establish appropriate safety and health practices and determine the applicability of regulatory limitations prior to use. For a specific hazard statement, see Note 3.*

NOTE 1—This test method and ISO 9772 are technically equivalent.

## 2. Referenced Documents

### 2.1 ASTM Standards:

D 4483 Practice for Determining Precision for Test Method Standards in the Rubber and Carbon Black Industries<sup>2</sup>

D 5025 Specification for Laboratory Burner Used for Small-Scale Burning Tests on Plastic Materials<sup>3</sup>

E 176 Terminology to Fire Standards<sup>4</sup>

E 437 Specification for Industrial Wire Cloth and Screens (Square Opening Series)<sup>5</sup>

### 2.2 ISO Standard:

ISO 9772 Cellular Plastics—Determination of Horizontal

Burning Characteristics of Small Specimens Subjected to a Small Flame<sup>6</sup>

## 3. Terminology

3.1 Definitions—For definitions of fire-related terms used in this test method, refer to Terminology E 176.

3.2 afterflame time,  $n$ —the length of time for which a material continues to flame, under specified conditions, after the ignition source has been removed.

3.3 afterglow time,  $n$ —the length of time for which a material continues to glow under specified test conditions, after the ignition source has been removed or cessation of flaming, or both.

3.4 flame,  $vb$ —to undergo combustion in the gaseous phase with emission of light.

3.5 glow,  $n$ —visible light, other than from flaming, emitted by a solid undergoing combustion.

## 4. Summary of Test Method

4.1 This test method for measuring the burning characteristics of cellular polymeric materials employs a small standard test specimen 50 by 150 mm. The specimen is supported horizontally. One end is exposed to a specified gas flame for 60 s and the extent of burning is measured.

## 5. Significance and Use

5.1 This test method provides a means of measuring the time and extent of burning for cellular polymeric materials. It also provides a means of measuring burning rates for materials that continue to burn past the specified gage marks.

5.2 This test method provides a means of comparing the burning characteristics of materials of like thickness density, cell size, and skin irregularities, including the effect of falling particles of cellular polymeric materials. It may be used for quality control, specification acceptance, and for research and development. Such materials may be filled or reinforced, rigid or flexible, cut or formed.

5.3 In this test method, the specimens are subjected to one or more specific sets of laboratory fire test exposure conditions.

<sup>1</sup> This test method is under the jurisdiction of ASTM Committee D20 on Plastics and is the direct responsibility of Subcommittee D20.30 on Thermal Properties.

Current edition approved May 10, 2003. Published July 2003. Originally approved in 1989. Last previous edition approved in 1998 as D 4986 – 98.

<sup>2</sup> *Annual Book of ASTM Standards*, Vol 09.01.

<sup>3</sup> *Annual Book of ASTM Standards*, Vol 08.03.

<sup>4</sup> *Annual Book of ASTM Standards*, Vol 04.07.

<sup>5</sup> *Annual Book of ASTM Standards*, Vol 14.02.

<sup>6</sup> Available from American National Standards Institute (ANSI), 25 W. 43rd St., 4th Floor, New York, NY 10036.

\*A Summary of Changes section appears at the end of this standard.

If different test conditions are substituted or if the anticipated end-use conditions are changed, it may not be possible from this test method to predict changes in the performance characteristics measured. Therefore, the results are strictly valid only for the fire test exposure conditions described in this procedure.

5.4 This test method is not intended to be a criterion for fire hazard. The fire hazard created by materials depends upon the form and end use of the material. Assessment of fire hazard includes, but is not limited to, many factors such as flame spread, burning rate, ease of ignition, fuel contribution, heat evolution, products of combustion, and others.

**6. Apparatus**

6.1 *Test Chamber*—A laboratory hood free of induced or forced draft during test. The hood shall be totally enclosed, with a heat-resistant transparent window for observing the test. Alternatively, the test may be conducted in a cabinet placed inside the hood. The cabinet should be constructed of noncombustible materials and should have a transparent window for observing the test. The cabinet must provide adequate ventilation for characteristic burning, but must not allow drafts across the burning specimen; therefore, a suitable damper may be necessary.

6.2 *Laboratory Burner*—Burner shall be constructed in accordance with Specification D 5025.

6.3 *Wing Top*—Wing top, having an opening  $48 \pm 1$  mm in length by  $1.3 \pm 0.05$  mm in width fitted to the burner. (See Fig. 1.)

6.4 *Gas Supply*—Methane gas, technical grade or natural gas having a heat content of  $37 \pm 1$  MJ/m<sup>3</sup> with suitable regulator and meter for uniform gas flow.

6.5 *Wire Cloth*—Low-carbon, plain, steel wire, 6.4-mm mesh of  $0.90 \pm 0.05$ -mm wire diameter. The cloth mesh and wire diameter shall be determined in accordance with Specification E 437, Appendix X3. The wire cloth shall be cut to approximately 215 by 75 mm and shall be formed to provide a 90° bend at one end, 13 mm high. (See Fig. 1.)

6.6 *Support Fixture*—Any fixture that will support the wire cloth horizontally,  $13 \pm 1$  mm above the burner wing top and  $175 \pm 25$  mm above the base of the test chamber. Fig. 2 shows one acceptable arrangement.

6.7 *Timing Device(s)*—Accurate to  $\pm 1$  s.

6.8 *Linear Measuring Device*—Graduated in millimeters.

6.9 *Cotton*—A supply of dry, absorbent 100 % cotton.

6.10 *Desiccator*—Containing a suitable drying agent, capable of maintaining a relative humidity not exceeding 20 % at  $23 \pm 2^\circ\text{C}$ .

6.11 *Conditioning Room or Chamber*—Capable of being maintained at  $23 \pm 2^\circ\text{C}$  and a relative humidity of  $50 \pm 5$  %.

6.12 *Conditioning Oven*—A full-draft circulating air oven capable of being maintained at  $70 \pm 2^\circ\text{C}$ .

6.13 *Dial Gage Micrometer*—For measuring thicknesses with a 650-mm<sup>2</sup> pressure ft exerting a pressure of  $0.175 \pm 0.035$  kPa.

**7. Test Specimen**

7.1 Test specimens, for materials being considered in a range of colors, thicknesses and densities, shall have representative ranges of these colors, thicknesses and densities tested.

7.1.1 Test specimens in the minimum and maximum densities shall be considered representative of the range, if the test results yield the same flame test classification. If the burning characteristics are not essentially the same for all specimens representing the range, evaluation is to be limited only to the materials in the densities tested or additional test specimens in intermediate densities are to be tested to determine the range.

7.1.2 Uncolored test specimens and test specimens with the highest level of organic and inorganic pigment loading by weight are considered representative of the color range, if the test results yield the same flame test classification. When certain pigments are known to affect flammability characteristics, they are also to be tested. Test specimens to be tested are those that:

- (a) contain no coloring

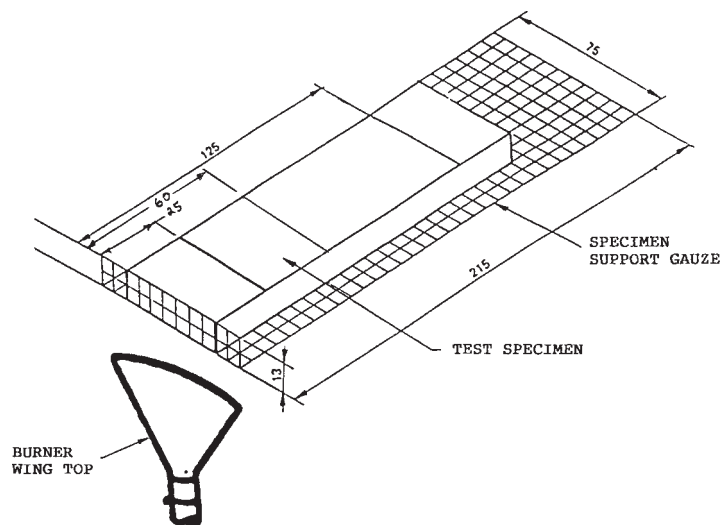

NOTE—Dimensions in millimetres.

FIG. 1 Test Specimen and Specimen Support Gauze

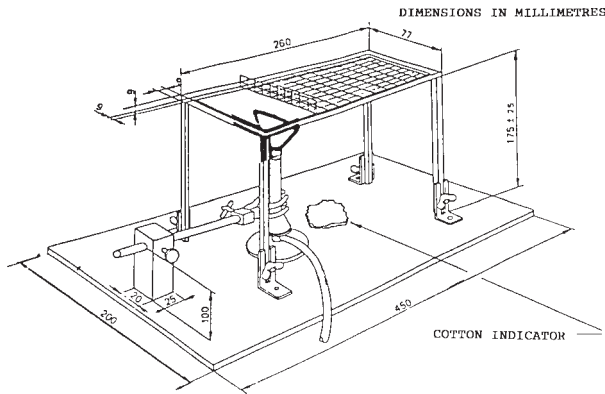

FIG. 2 Support Gauze Holder

(b) contain the highest level of organic pigments being considered for the respective application

(c) contain the highest level of inorganic pigments being considered for the respective application

(d) contain pigments which are known to adversely affect flammability characteristics

7.2 All specimens shall be cut from a representative sample of the material. Care shall be taken to remove all dust and any particles from the surface.

7.3 The standard test specimen shall be 150 mm ± 10 mm long by 50 mm ± 1 mm wide. Materials supplied in thicknesses over 13 mm shall be cut to 13 mm ± 1 mm thickness with any skin on one side. Materials supplied in thicknesses of 13 mm or less shall be tested at the thickness supplied, without removing any skin. (See 7.6.) If materials with adhesive applied are to be tested, specimens having adhesive on one side only shall be used. (See 7.6.)

NOTE 2—Tests made on test specimens of different thicknesses, or directions of anisotropy are not comparable.

7.4 Prepare a minimum of 20 specimens for the test. This includes 10 additional specimens in the event that the situation described in X1.3 or X1.5 is encountered.

7.5 Mark each specimen across its width with lines at 25 mm, 60 mm and 125 mm from one end, referred to hereafter as gauge marks (see Fig. 1).

7.6 Test specimens with a high density exterior (skin) on one side shall be tested with this side facing down. Test specimens with adhesive on one side shall be tested with this side facing up.

## 8. Conditioning

8.1 Condition specimen sets as follows:

8.1.1 Condition one set of five specimens for at least 48 h at a temperature of 23 ± 2°C and a relative humidity of 50 ± 5 % prior to testing.

8.1.2 Condition a second set of five specimens in a circulating air oven for 168 ± 2 h at 70 ± 2°C, and then cool in a desiccator for at least 4 h at room temperature prior to testing.

8.2 All specimens shall be tested in a laboratory atmosphere of 15 to 35°C and 45 to 75 % relative humidity.

## 9. Procedure

NOTE 3—**Warning:** Conduct the burning test in an enclosed laboratory hood or cabinet free of induced or forced draft. An exhaust fan is required

for removing the products of combustion which may be toxic, immediately after the test.

NOTE 4—To maintain a draft-free environment during the test, it may be necessary to install a damper in the exhaust duct which can be closed during the test.

9.1 Position the formed wire cloth in the support fixture so that the major section is horizontal and the upturned edge is nearest the burner. The bottom of the cloth shall be 13 ± 1 mm above the burner wing top and 175 mm above the base of the test chamber. Place 0.05 to 0.08 g of cotton thinned to an area approximately 75 × 75 mm and a maximum thickness of 6 mm, on the base of the test chamber under the front portion of the wire cloth having the upturned ends.

9.2 Place the test specimen flat on the wire cloth with the 150 by 50-mm surface horizontal. The end of the specimen closer to the 60-mm mark is to be placed in contact with the upturned end of the wire cloth. (See Fig. 1.)

9.3 Place the burner, with wing top, remote from the specimen, ignite, and adjust it to produce a blue flame 38 mm high. Adjust the gas supply and the air ports of the burner until a yellow-tipped blue flame is produced, and then increase the air supply until the yellow tip just disappears. Measure the height of the flame, and, if necessary, readjust to obtain a flame 38 ± 2 mm high.

9.4 Place the burner under the upturned end of the wire cloth so that one edge of the flame is in line with the upturned end and the other edge of the flame extends into the front end of the specimen. (See Fig. 3.) The center of the wing top is to be in line with the longitudinal axis of the specimen.

9.5 Start the timing device(s) when the test flame is applied. Remove the flame after 60 s. Record the times when the flame reaches the 25-mm, 60-mm, or 125-mm mark, when the specimen extinguishes.

9.6 If the specimen burns past the 125-mm mark, the time for the specimen to burn from the 25-mm mark to the 125-mm

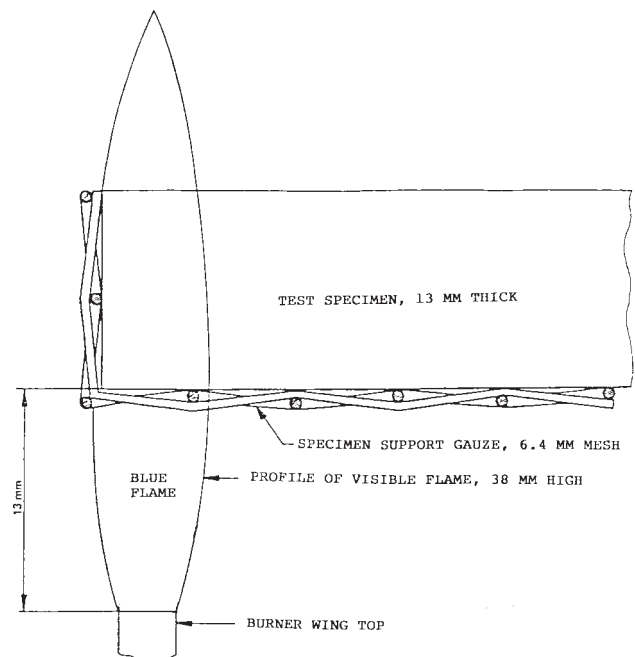

FIG. 3 Details of Flame and Relative Positions of Burner Wing Top, Test Specimen, and Specimen Support Gauze

mark is to be determined. Record the time, in seconds, as the burning time,  $t$ . Calculate the burning rate as  $600/t$  cm/min.

9.7 If the specimen ceases to burn, the duration of the total afterflame plus afterglow time after removal of the test flame is to be recorded. The furthest distance affected by burning (flaming plus glowing) is to be measured and recorded. Also, it is to be noted whether or not the cotton placed 175 mm below the test specimen was ignited by flaming particles.

9.8 If the specimen does not burn after removal of the test flame, record the duration of afterflame time as zero. The furthest distance affected by burning is to be measured and recorded. Note whether or not the cotton was ignited.

9.9 Repeat the procedure in 9.1 through 9.8 on the four remaining specimens for each set. If a new wire cloth is not used for each test, any material remaining on the wire cloth from previous tests is to be burned off and the wire cloth allowed to cool to room temperature before conducting the test.

NOTE 5—When the test chamber is in continuous use, heating of the chamber may affect test results.

## 10. Report

10.1 The complete report shall include the following:

10.1.1 *Material Identification*—The generic description, manufacturer, commercial designation, lot number, color, conditioning, density, thickness, and the presence or absence of skin.

10.1.2 The burning rate of each specimen that has burned to the 125-mm mark.

10.1.3 The duration of afterflame and afterglow time and the distance affected for each specimen.

10.1.4 Whether or not any of the specimens drip flaming particles that ignite cotton.

10.1.5 Note any unusual burning phenomena, such as warpage, shrinkage, melting, or other atypical responses.

10.1.6 The statement: These data describe the response of materials to heat and flame under controlled laboratory conditions and should not be used for the appraisal or regulation of the fire hazards associated with them under actual fire conditions.

10.1.7 If the material will be classified, indicate the category designation from the classification system in Appendix X1.

## 11. Precision and Bias

11.1 An interlaboratory test program was conducted to obtain precision data for this test method. Both precision and bias sections were prepared in accordance with Practice D 4483.

### 11.2 Test Method:

11.2.1 The interlaboratory program was a Type 1 precision conducted in 1990. Both repeatability and reproducibility were short term. A test result is the average value obtained from five determinations. A single test result was obtained for two fire test responses for all materials on each of two separate days.

11.2.2 Nine different materials were used in this study and nine laboratories participated in the interlaboratory program.

11.2.2.1 The precision results in this precision and bias section give an estimate of the precision of this test method with the materials used in this particular interlaboratory program. These precision parameters should not be used for acceptance or rejection testing of any group of materials without documentation that they are applicable.

11.2.3 All materials were prescreened for properties by one laboratory and then forwarded to a second laboratory. The second laboratory prepared all samples for testing and distributed them to the other participating laboratories. The test specimens only had to be conditioned in accordance with this test method prior to actual testing.

11.2.4 Material testing order was randomized.

11.2.5 The results of the precision calculations for repeatability and reproducibility are given in Table 1.

11.2.6 *Repeatability*—The repeatability,  $r$ , of this test method has been established in Table 1. Two single test results obtained within one laboratory that differ by more than this tabulated  $r$  (for any given material) must be considered to have come from different or nonidentical sample populations.

11.2.7 *Reproducibility*—The reproducibility,  $R$ , of this test method has been established in Table 1. Two single test results obtained in different laboratories that differ by more than this tabulated  $R$  (for any given material) must be considered to have come from different or nonidentical sample populations.

11.2.8 *Bias*—In test method terminology, bias is the difference between an average test value and the reference (true) test property value. Reference values do not exist for this test method since the value or level of the test property is exclusively defined by this test method. Bias, therefore, cannot exist.

## 12. Keywords

12.1 burning characteristics; burning rate; cellular materials; horizontal

**TABLE 1 Type 1 (Test) Horizontal Burning Characteristics**

Part 1 Burn Times, s						
Material	Mean	Within Laboratories		Between Laboratories		
		Sr	r	SR	R	
A	60.8	8.0	22.6	22.7	64.3	
B	77.1	12.5	35.4	15.4	43.5	
C	109.4	23.3	66.0	30.2	85.3	
D	185.9	62.5	177.0	86.6	245.2	
E	6.5	6.7	18.8	8.8	24.8	
F	10.3	12.4	35.1	18.8	53.1	
G	2.3	5.7	16.3	7.4	21.0	
H	4.1	2.1	6.0	8.5	24.1	
I	0.6	0.7	1.9	1.8	5.1	
Average Pooled Values	50.8	23.4	66.1	32.9	93.0	

Part 2 Burn Lengths, mm						
Material	Mean	Within Laboratories		Between Laboratories		
		Sr	r	SR	R	
A	99.4	5.3	14.9	5.3	14.9	
B	100.0	0.0	0.0	0.0	0.0	
C	98.9	10.5	29.6	10.5	29.6	
D	80.2	19.3	54.7	24.6	69.9	
E	18.9	3.3	9.3	8.3	23.5	
F	52.3	18.5	35.2	23.8	67.3	
G	26.7	9.4	90.5	14.5	41.1	
H	24.6	8.7	19.1	11.0	31.0	
I	6.0	2.1	16.6	8.4	23.9	
Average Pooled Values	56.3	10.7	30.3	14.1	39.8	

Sr = Within-laboratory standard deviation.  
r = Repeatability.  
SR = Between-laboratory standard deviation.  
R = Reproducibility.

## APPENDIX

### (Nonmandatory Information)

#### X1. CLASSIFICATION SYSTEM FOR DETERMINING THE COMPARATIVE HORIZONTAL BURNING CHARACTERISTICS OF CELLULAR POLYMERIC MATERIALS

X1.1 This appendix describes a classification system that can be used to characterize the burning behavior of cellular materials, supported in a horizontal position, in response to a small flame ignition source. The use of a category designation code is optional and is determined by examining the test results of materials tested by this test method. Each category code represents a preferred range of performance levels that simplifies description in material designations or specifications and may assist certification bodies to determine compliance with applicable requirements.

#### X1.2 Materials Classified HBF—Materials classified HBF shall perform as follows:

X1.2.1 HBF materials shall not have any specimens with a burning rate exceeding 40 mm/min over a 100 mm span, or

X1.2.2 HBF materials shall have each specimen cease to burn before flaming or glowing reaches the 125 mm gage mark.

X1.3 If only one specimen from a set of five specimens does not comply with the requirements in X1.2, another set of five specimens, subjected to the same conditioning, shall be tested. All specimens from this second set of specimens shall

comply with the requirements in X1.2 for the material in that thickness and density to be classed HBF.

X1.4 *Materials Classified HF1 and HF2*—Materials classified HF1 and HF2 shall be in compliance with Table X1.1.

X1.5 If a set of five specimens does not comply with the requirements in X1.4, because of one of the following situations, another set of five specimens subjected to the same conditioning shall be tested as follows:

X1.5.1 A single specimen flames for more than 10 s; or,

X1.5.2 Two specimens flame for more than 2 s but less than 10 s; or,

**TABLE X1.1 Material Classifications**

Criteria Conditions	HF1	HF2
Afterflame time	4/5 is $\leq 2$ s <sup>A</sup> 1/5 is $\leq 10$ s <sup>B</sup>	4/5 is $\leq 2$ s <sup>A</sup> 1/5 is $\leq 10$ s <sup>B</sup>
Afterglow time for each individual specimen	$\leq 30$ s	$\leq 30$ s
Cotton indicator ignited by flaming particles or drops	No	Yes
Damaged length for each individual specimen	$< 60$ mm	$< 60$ mm

<sup>A</sup> 4/5—Four out of a set of five specimens.

<sup>B</sup> 1/5—One out of a set of five specimens.

X1.5.3 One specimen flames for more than 2 s but less than 10 s, and a second specimen flames for more than 10 s; or,

X1.5.4 One specimen does not comply with the additional criteria in X1.4.

X1.6 All specimens from this second set shall comply with the requirements in X1.4 in order for the foamed plastic material in that thickness and density to be classed HF1 or HF2.

## SUMMARY OF CHANGES

This section identifies the location of selected changes to this test method. For the convenience of the user, Committee D20 has highlighted those changes that may impact the use of this test method. This section may also include descriptions of the changes or reasons for the changes, or both.

### *D 4986 – 03:*

(1) Revised Section 7 to incorporate more extensive specimen selection criteria.

### *D 4986 – 98:*

(1) Specified the density of a cellular material covered by this test method (1.1).

(2) Added an ISO equivalency statement (Note 1).

(3) Added an option to use a classification system to categorize materials (1.2, 10.1.7 and Appendix X1).

(4) Added a reference to ISO 9772 and removed the reference to ISO 3582 (2.2).

(5) Provided terminology for *afterflame time* and *afterglow time* (3.2 and 3.3).

(6) Deleted reference to joint task group with D 11.17 (5.4).

(7) Removed references to inch-pound units and added tolerances to critical dimensions for harmonization with ISO 9772.

(8) Added a Dial Gage Micrometer with a pressure foot to the Apparatus Section (6.13).

(9) Added requirements for the amount of cotton to be used (9.1).

(10) Added a marker line on the specimen at 60 mm from the upturned end of the wire cloth so that the material can be classified HF1 or HF2 (9.2, 9.5 and Appendix X1).

*ASTM International takes no position respecting the validity of any patent rights asserted in connection with any item mentioned in this standard. Users of this standard are expressly advised that determination of the validity of any such patent rights, and the risk of infringement of such rights, are entirely their own responsibility.*

*This standard is subject to revision at any time by the responsible technical committee and must be reviewed every five years and if not revised, either reapproved or withdrawn. Your comments are invited either for revision of this standard or for additional standards and should be addressed to ASTM International Headquarters. Your comments will receive careful consideration at a meeting of the responsible technical committee, which you may attend. If you feel that your comments have not received a fair hearing you should make your views known to the ASTM Committee on Standards, at the address shown below.*

*This standard is copyrighted by ASTM International, 100 Barr Harbor Drive, PO Box C700, West Conshohocken, PA 19428-2959, United States. Individual reprints (single or multiple copies) of this standard may be obtained by contacting ASTM at the above address or at 610-832-9585 (phone), 610-832-9555 (fax), or service@astm.org (e-mail); or through the ASTM website (www.astm.org).*