



Standard Test Method for Measuring the Comparative Burning Characteristics and Resistance to Burn-Through of Solid Plastics Using a 125-mm Flame¹

This standard is issued under the fixed designation D 5048; the number immediately following the designation indicates the year of original adoption or, in the case of revision, the year of last revision. A number in parentheses indicates the year of last reapproval. A superscript epsilon (ϵ) indicates an editorial change since the last revision or reapproval.

1. Scope*

1.1 This fire-test-response test method covers a small-scale laboratory procedure for determining the relative burning characteristics and the resistance to burn-through of plastics using small bar and plaque specimens exposed to a 125-mm (500-W nominal) flame.

NOTE 1—This test method and IEC 60695-11-20 are technically equivalent.

NOTE 2—For additional information on comparative burning characteristics of solid plastics in a vertical position, see Test Method D 3801.

1.2 This test method was developed for polymeric materials used for parts in devices and appliances. The results are intended to serve as a preliminary indication of their acceptability with respect to flammability for a particular application. The final acceptance of the material is dependent upon its use in complete equipment that conforms with the standards applicable to such equipment.

1.3 The classification system described in Appendix X1 is intended for quality assurance and the preselection of component materials for products.

1.4 This test method may be applied to other nonmetallic materials if found to be appropriate.

1.5 This test method is not intended to cover plastics when used as materials for building construction or finishing.

1.6 *This standard is used to measure and describe the response of materials, products, or assemblies to heat and flame under controlled conditions, but does not by itself incorporate all factors required for fire hazards or fire risk assessment of materials, products, or assemblies under actual fire conditions.*

1.7 *This standard does not purport to address all of the safety concerns, if any, associated with its use. It is the responsibility of the user of this standard to establish appropriate safety and health practices and determine the applica-*

bility of regulatory limitations prior to use. See 6.1 for a specific hazard statement.

2. Referenced Documents

2.1 ASTM Standards:

D 883 Terminology Relating to Plastics²

D 3801 Test Method for Measuring the Comparative Burning Characteristics of Solid Plastics in a Vertical Position³

D 5025 Specification for a Laboratory Burner Used for Small-Scale Burning Tests on Plastic Materials⁴

D 5207 Practice for Calibration of 20 and 125-mm Test Flames for Small-Scale Burning Tests on Plastic Materials⁴

E 176 Terminology of Fire Standards⁵

E 691 Practice for Conducting an Interlaboratory Study to Determine the Precision of a Test Method⁶

2.2 IEC Standard:⁷

IEC 60695-11-20 Fire Hazard Testing-Part 11-20: Test Flames - 500 W Flame Test Methods

3. Terminology

3.1 *Definitions*—For terms relating to plastics, the definitions in this test method are in accordance with Terminology D 883. For terms relating to fire, the definitions used in this test method are in accordance with Terminology E 176.

3.2 Definitions of Terms Specific to This Standard:

3.2.1 *afterflame*—persistence of flaming of a material, after the ignition source has been removed.

3.2.2 *afterflame time*—the length of time for which a material continues to flame, under specified conditions, after the ignition source has been removed.

¹ This test method is under the jurisdiction of ASTM Committee D20 on Plastics and is the direct responsibility of Subcommittee D20.30 on Thermal Properties.

Current edition approved March 10, 2003. Published April 2003. Originally approved in 1990. Last previous edition approved in 1997 as D 5048 – 97.

² *Annual Book of ASTM Standards*, Vol 08.01.

³ *Annual Book of ASTM Standards*, Vol 08.02.

⁴ *Annual Book of ASTM Standards*, Vol 08.03.

⁵ *Annual Book of ASTM Standards*, Vol 04.07.

⁶ *Annual Book of ASTM Standards*, Vol 14.02.

⁷ Publications of the International Electrotechnical Commission (IEC) are available from American National Standards Institute (ANSI), 25 W. 43rd St., 4th Floor, New York, NY 10036.

*A Summary of Changes section appears at the end of this standard.

3.2.3 *afterglow*—persistence of glowing of a material, after cessation of flaming or, if no flaming occurs, after removal of the ignition source.

3.2.4 *afterglow time*—the length of time for which a material continues to glow under specified test conditions, after the ignition source has been removed or cessation of flaming, or both.

3.2.5 *burn-through*—a hole produced in the plaque specimen.

4. Summary of Test Method

4.1 Sets of 13 by 125-mm bar specimens and 150 by 150-mm plaque specimens are subjected to a 125-mm flame with a 40-mm inner blue cone, for five 5-s flame applications. The afterflame plus afterglow time for the bar specimen is recorded after removal of the fifth flame application. Information is recorded on whether or not flaming material drips from the specimens, and whether or not the plaque specimens exhibit burn-through.

5. Significance and Use

5.1 The test results represent afterflame plus afterglow time, in seconds, for a material under the conditions of the test. The test results for plaques also indicate whether or not the specified flame will burn through a material.

5.2 The effect of material thickness, colors, additives, deterioration, and possible loss of volatile components is measurable.

5.3 The burning characteristics may vary with thickness. Test data should only be compared with data for materials of comparable thickness.

5.4 The results serve as a reference for comparing the relative performance of materials and can be an aid in material selection.

5.5 In this test method, the specimens are subjected to specific laboratory test conditions. If different test conditions are substituted or the end-use conditions are changed, it will not always be possible by or from this test method to predict changes in the fire-test-response characteristics measured. Therefore, the results are valid only for the fire-test-exposure conditions described in this test method.

6. Apparatus

6.1 *Test Chamber*, enclosure or laboratory hood with a minimum capacity of approximately 0.5 m³, free of induced or force draft during test. An enclosed laboratory hood with a heat-resistant glass window and an exhaust fan for removing the products of combustion after the tests are recommended. Laboratory hoods may have induced drafts, even with the exhaust fan off. A positive closing damper may be needed.
Warning—Products of combustion may be toxic. An exhaust fan is recommended for removing the products of combustion immediately after the test.

NOTE 3—It has been suggested that for samples which display extended afterflame times, a hood of 1.0 m³ or greater may be necessary to ensure an adequate supply of oxygen to the burning sample. If the oxygen supply to the sample is less than adequate during testing, incorrect results may be obtained.

6.2 *Burner*, tirrill type, as described in Specification D 5025.

6.3 *Ring Stand*, with a clamp or the equivalent, adjustable for vertical positioning of bar specimens and horizontal positioning of plaque specimens.

6.4 *Gas Supply*, a supply of technical-grade methane gas with suitable regulator and meter for uniform gas flow. Natural gas having an energy density of approximately 37 mJ/m³ [1000 Btu/ft³] has been found to provide similar results. However, technical-grade methane gas shall be used as the referee gas in cases of dispute.

6.5 *Burning Mounting Fixture*, a fixture capable of positioning the burner at an angle of 20 ± 2° from the vertical.

6.6 *Timing Device*, accurate to 0.5 s.

6.7 *Cotton*, a supply of absorbent 100 % cotton.

6.8 *Desiccator*, containing anhydrous calcium chloride.

6.9 *Conditioning Room or Chamber*, capable of being maintained at 23 ± 2°C and a relative humidity of 50 ± 5 %.

6.10 *Conditioning Oven*, a full-draft circulating air oven capable of being maintained at 70 ± 1°C.

7. Sampling

7.1 Unless otherwise agreed upon, material shall be sampled in accordance with good statistical practice.

8. Test Specimens

8.1 The standard bar specimen shall be 13 ± 0.5 by 125 ± 5 mm. The standard plaque specimen shall be 150 ± 5 by 150 ± 5 mm. Bar and plaque specimens shall be in the thickness appropriate to the objectives of the determination. Materials thicker than 13 mm should not be tested by this test method.

8.2 Surfaces must be smooth and unbroken. Corner radius must not exceed 1.3 mm. Edges must be fine-sanded to remove burrs, saw marks, and residual filaments.

8.3 The results of tests carried out on test specimens of different, colors, thicknesses, densities, molecular masses, directions of anisotropy and types, or with different additives, fillers/reinforcements can be different.

8.3.1 Test specimens in the extremes of the densities, melt flows and fillers/reinforcements contents may be provided and considered representative of the range, if the results yield the same flame test classification. If the burning characteristics are not essentially the same for all specimens representing the range, the evaluation is to be limited only to the materials in the densities, melt flows, and fillers/reinforcements contents tested. Additional test specimens in the intermediate densities, melt flows, and fillers/reinforcements contents are to be tested.

8.3.2 Uncolored test specimens and test specimens with the highest level of organic and inorganic pigment loading by weight are considered representative of the color range, if the test results are essentially the same. When certain pigments are known to affect flammability characteristics, they are also to be tested. Test specimens to be tested are those that:

- (a) contain no coloring
- (b) contain the highest level of organic pigments
- (c) contain the highest level of inorganic pigments
- (d) contain pigments which are known to adversely affect flammability characteristics

9. Conditioning

9.1 Condition one set of five bar specimens and three plaque specimens for at least 48 h at a temperature of $23 \pm 2^\circ\text{C}$ and a relative humidity of $50 \pm 5\%$ prior to testing.

9.2 Condition a second set of five bar specimens and three plaque specimens in a circulating air oven for a duration of 168 h at $70 \pm 1^\circ\text{C}$, and then cool in a desiccator over anhydrous calcium chloride for at least 4 h at room temperature prior to testing.

9.3 All specimens shall be tested in a laboratory atmosphere of 15 to 35°C and 45 to 75 % relative humidity.

10. Procedure

10.1 *Procedure A—Test of Bar Specimens:*

10.1.1 Conduct the burning test in a chamber, enclosure, or laboratory hood free of induced or forced draft.

10.1.2 Support a specimen from the upper 6 mm of the specimen, with the longitudinal axis vertical, by the clamp on the ring stand so that the lower end of the specimen is 300 ± 10 mm above a horizontal layer of cotton, approximately 50 by 50 mm, thinned to a maximum uncompressed thickness of 6 mm, maximum weight of 0.08 g.

NOTE 4—To form the horizontal layer, a small portion (approximately 13 by 25 mm of cotton may be pulled from the supply with the fingers and then thinned and spread into a 50 by 50-mm square having a free-standing thickness of 6 mm.

10.1.3 Place the burner remote from the specimen, ignite, and adjust it so that when the burner is in a vertical position, the overall height of the flame is 125 mm, and the height of the inner blue cone is 40 mm. Support the burner on the inclined plane of the mounting fixture so that the burner tube is positioned at $20 \pm 5^\circ$ from the vertical.

NOTE 5—See Practice D 5207 for recommended back pressure and flow rate for the gas supply and calibration procedure for the 125-mm flame.

10.1.4 Apply the flame to one of the lower corners of the

specimen at an angle of $20 \pm 5^\circ$ from the vertical, so that the tip of the blue cone touches the specimen (see Fig. 2). Apply the flame for 5 ± 0.5 s and then remove the flame for 5 ± 0.5 s. Repeat this operation until the specimen has been subjected to five applications of the test flame. If the specimen drips particles, shrinks, or elongates during the test, move the burner so that the tip of the inner blue cone maintains contact with the major portion of the specimen at the corner. It may be necessary to hand-hold the burner and fixture to accomplish this. After the fifth removal of the test flame, record, in seconds, the total afterflame time and afterflame plus afterglow times. Note whether or not the specimen dripped flaming particles that ignited the cotton.

NOTE 6—If necessary, conduct the test in subdued lighting to observe glowing.

10.1.5 Repeat the procedure in 10.1.2-10.1.4 on the remaining specimens for each set, one set conditioned as described in 9.1 and one set conditioned as described in 9.2.

10.1.6 Calculate the arithmetic mean of the afterflame time and afterflame plus afterglow times for each set of five specimens.

10.2 *Procedure B—Test of Plaque Specimens:*

10.2.1 Proceed as in 10.1.1.

10.2.2 Support a plaque specimen at its edges so that it is horizontal, using a clamp and ring stand or other equivalent means.

10.2.3 Proceed as in 10.1.3.

10.2.4 Apply the flame to the center of the plaque at an angle of $20 \pm 5^\circ$ from the vertical so that the tip of the inner blue cone touches the approximate center of the bottom surface (see Fig. 3). Apply the flame for 5 ± 0.5 s and then remove the flame for 5 ± 0.5 s. Repeat this operation until the plaque has been subjected to five applications of the test flame. It may be necessary to hand-hold the burner and fixture so that the tip of the inner blue cone maintains contact with the surface of the

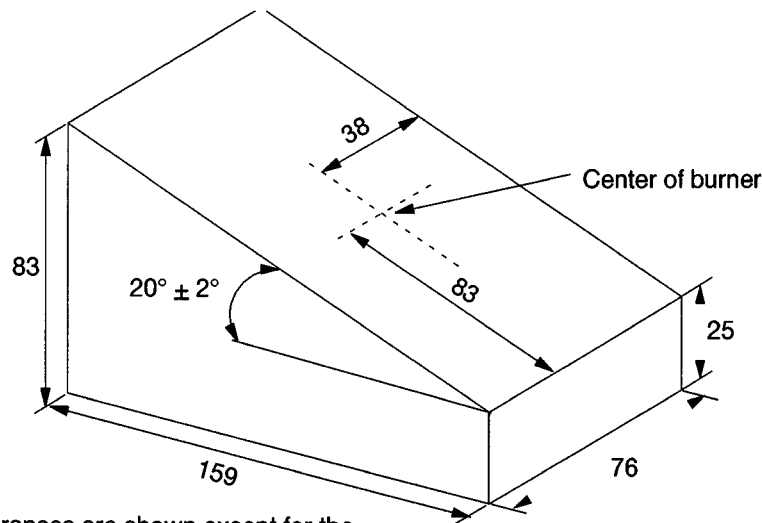

No tolerances are shown except for the angle because it is an example only.

Dimensions in millimeters

FIG. 1 Burner Mounting Block—Example

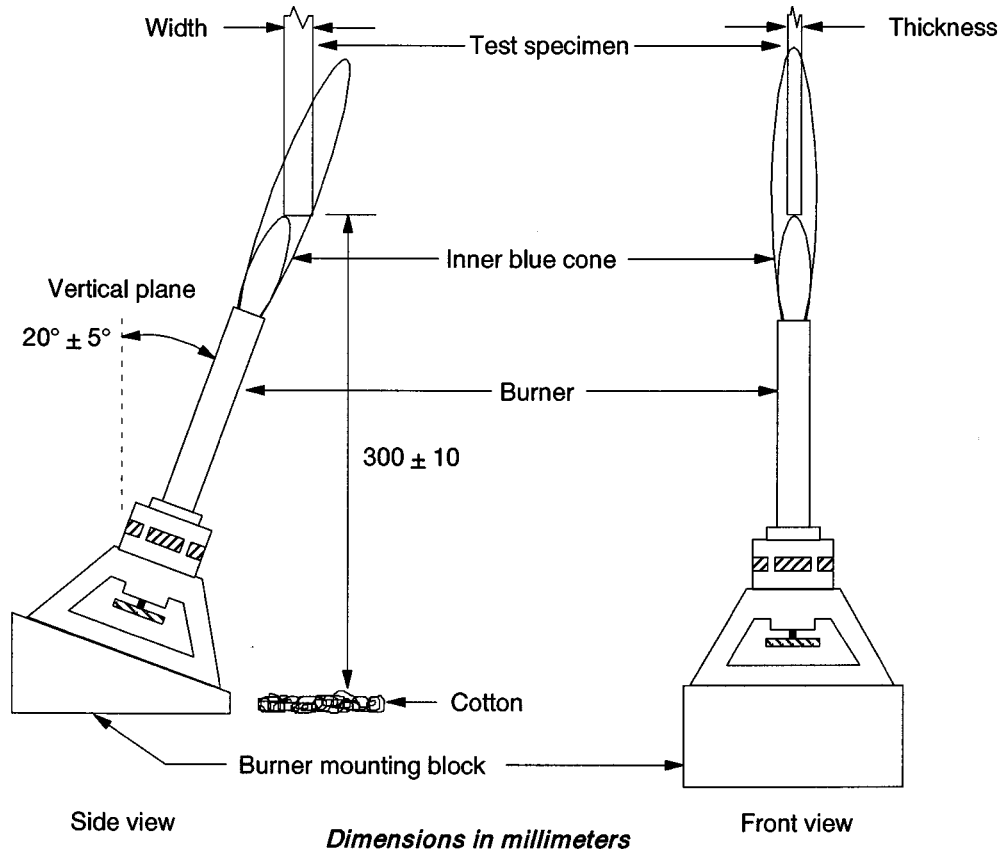

FIG. 2 Procedure A—Test of Bar Specimens

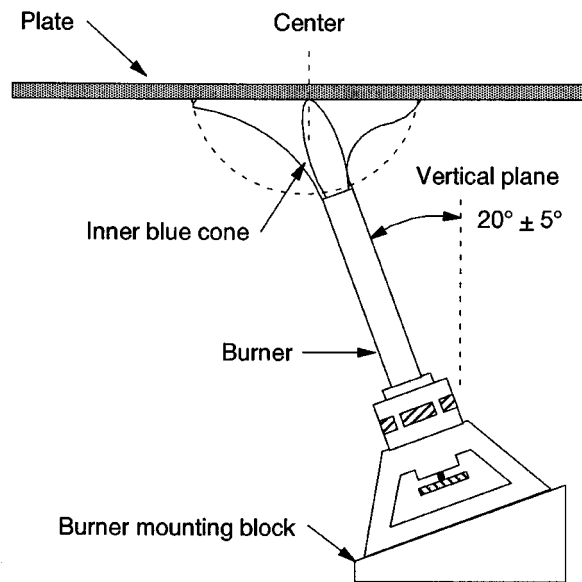

FIG. 3 Procedure B—Test of Plaque Specimens

plaque. After the fifth removal of the test flame, note whether or not the flame burned through the plaque.

10.2.5 Repeat the procedure in 10.2.2-10.2.4 on the remaining plaques for each set, one set conditioned as described in 9.1 and one set conditioned as described in 9.2.

11. Report

11.1 The complete report shall include the following information:

11.1.1 Generic description, manufacturer, commercial designation, lot number, and color,

11.1.2 Conditioning time at $23 \pm 2^\circ\text{C}$, in hours, for specimens conditioned in accordance with 9.1,

11.1.3 Cooling time in desiccator, in hours, for specimens conditioned in accordance with 9.2,

11.1.4 Average thickness for each set,

11.1.5 Total afterflame time and afterflame plus afterglow times after the fifth flame application for each specimen,

11.1.6 Arithmetic means of afterflame time and afterflame plus afterglow times for each specimen set,

11.1.7 Whether or not any of the specimens drip flaming particles which ignite the cotton swatch, and

11.1.8 Whether or not any of the plaques burn through after the fifth flame application.

are specific to the round robin and may not be representative of other lots, conditions, materials, or laboratories. Users of this test method should apply the principles outlined in Practice E 691 to generate data specific to their laboratory and materials, or between specific laboratories. The principles of 12.2-12.2.3 would then be valid for such data.

12.2 *Concept of r and R* —If S_r and S_R have been calculated from a large enough body of data, and for test results that were averages from testing five specimens:

12.2.1 *Repeatability*—In comparing two test results for the same material, obtained by the same operator using the same equipment on the same day, the two test results should be judged not equivalent if they differ by more than the r value for that material.

TABLE 1 Average Afterflame Time

Material ^A	Average Specimen Thickness, mm	Average Afterflame Time, s				
		Average	S_r^B	S_R^C	r^D	R^E
Polybutylene Terephthalate I	3.2	0.91	0.35	0.63	0.98	1.76
Polybutylene Terephthalate II	3.1	1.25	0.53	1.09	1.48	3.05
Polyamide	3.2	1.48	0.28	0.85	0.78	2.38
Polycarbonate	3.2	2.17	0.49	1.05	1.37	2.94
Unsaturated Polyester I	1.6	6.37	2.42	5.35	6.78	14.98
Modified Polyphenylene Ether	3.2	10.97	3.75	5.84	10.50	16.35
Unsaturated Polyester II	2.7	110.4	31.0	70.5	86.8	197.3

^A Specimens conditioned in accordance with 9.1.

^B S_r = Within-laboratory standard deviation of the average.

^C S_R = Between-laboratory standard deviation of the average.

^D $r = 2.8 S_r$.

^E $R = 2.8 S_R$.

TABLE 2 Average Afterflame Plus Afterglow

Material ^A	Average Specimen Thickness, mm	Average Afterflame Plus Afterglow				
		Average	S_r^B	S_R^C	r^D	R^E
Polyamide	3.2	1.57	0.36	0.93	1.01	2.60
Polycarbonate	3.2	2.23	0.47	1.01	1.32	2.83
Unsaturated Polyester I	1.6	8.18	1.99	5.43	5.57	15.20
Modified Polyphenylene Ether	3.2	11.04	3.75	5.80	10.50	16.24
Polybutylene Terephthalate I	3.2	12.13	1.97	3.54	5.52	9.91
Polybutylene Terephthalate II	3.1	12.52	1.02	3.16	2.86	8.85
Unsaturated Polyester II	2.7	110.5	30.9	70.3	86.5	196.8

^A Specimens conditioned in accordance with 9.1.

^B S_r = Within-laboratory standard deviation of the average.

^C S_R = Between-laboratory standard deviation of the average.

^D $r = 2.8 S_r$.

^E $R = 2.8 S_R$.

12. Precision and Bias

12.1 Table 1 and Table 2 are based on a round robin completed in 1988 in accordance with Practice E 691, involving seven materials tested by thirteen laboratories. The tests were conducted in accordance with Procedure A, with conditioning described in 9.1. Each test result was the average of five individual determinations. Each laboratory obtained three test results for each material.

12.1.1 Since Procedure B results in go or no-go data, there is no recognized standard for developing a precision statement.

NOTE 7—The explanations of r and R given in 12.2-12.2.3 are only intended to present a meaningful way of considering the approximate precision of this test method. The data in Table 1 and Table 2 should not be rigorously applied to acceptance or rejection of material, as those data

12.2.2 *Reproducibility*—In comparing two test results for the same material, obtained by different operators using different equipment on different days, the two test results should be judged not equivalent if they differ by more than the R value for that material.

12.2.3 Any judgment in accordance with 12.2.1 and 12.2.2 would have an approximate 95 % probability of being correct.

12.3 *Bias*—There are no recognized standards on which to base an estimate of bias for this test method.

13. Keywords

13.1 burning characteristics; flammability; plastics; solid; resistance to burn-through; small-scale burning tests; vertical burning tests

APPENDIX
(Nonmandatory Information)
X1. CLASSIFICATION SYSTEM FOR THE COMPARATIVE BURNING CHARACTERISTICS AND RESISTANCE TO BURN-THROUGH OF SOLID PLASTICS USING A125-mm FLAME
TABLE X1.1 Materials Classifications^A

Criteria	Conditions	5VA	5VB
Individual bar specimen afterflame plus afterglow time after the fifth flame application, s		<60	<60
Was the cotton indicator ignited by flaming particles or drops from any bar specimen?		no	no
Did the flame penetrate through (burn-through) any of the individual plaques?		no	yes

^A If only one specimen from a set of five bar specimens or one plaque from a set of three plaques for a given preconditioning treatment does not comply with all criteria for a category, another set of five bar specimens or three plaques subjected to the same preconditioning shall be tested. All specimens or plaques from the second set shall comply with all specified criteria for the category.

X1.1 This appendix describes a classification system that may be used to characterize the burning behavior of solid

plastics in response to a 125-mm flame ignition source. The use of a category designation code is optional and is determined by examining the test results of materials tested by this test method. Each category code represents a preferred range of performance levels that simplifies description in material designations or specifications and may assist certification bodies to determine compliance with applicable requirements.

X1.2 The material may be classified in one of the categories shown in Table X1.1 by selecting the appropriate column using test results to answer the conditional questions posed.

X1.3 Recording the category designation in the test report is optional.

SUMMARY OF CHANGES

This section identifies the location of selected changes to this test method. For the convenience of the user, Committee D20 has highlighted those changes that may impact the use of this test method. This section may also include descriptions of the changes or reasons for the changes, or both.

D 5048 – 03:

- (1) Revised paragraph 1.4 for Committee E05 reference boilerplate.
- (2) Removed reference to Practice D 1898.
- (3) Added test specimen selection criteria in 8.3.
- (4) Added Figure 1 and updated and renumbered the other two existing figures.

D 5048 – 97:

- (1) Revised scope to provide additional background information.
- (2) Added IEC/ISO equivalency statement (Note 1).
- (3) Added cross reference to Test Method D 3801 (Note 2).
- (4) Deleted Practice D 618, Terminology D 1600, and UL94 throughout.
- (5) Added *Definitions of Terms Specific to This Standard* to

align with international methods.

- (6) Added 5.4 applicable to fire-test-response standards.
- (7) Added tolerances to burner mounting fixture (6.5), plaque dimensions (8.1), height above cotton (10.1.2), and flame application times (10.1.4 and 10.2.4).
- (8) Revised tolerance for timing device (6.6) and bar specimens (8.1).
- (9) Updated description of cotton (6.7 and 10.1.2).
- (10) Added reference to Practice D 5207 (Note 5).
- (11) Added Keywords (Section 13).
- (12) Added appendix with classification system for 5VA and 5VB.
- (13) Deleted (old) Note 1 under Significance and Use in favor of the new appendix.

ASTM International takes no position respecting the validity of any patent rights asserted in connection with any item mentioned in this standard. Users of this standard are expressly advised that determination of the validity of any such patent rights, and the risk of infringement of such rights, are entirely their own responsibility.

This standard is subject to revision at any time by the responsible technical committee and must be reviewed every five years and if not revised, either reapproved or withdrawn. Your comments are invited either for revision of this standard or for additional standards and should be addressed to ASTM International Headquarters. Your comments will receive careful consideration at a meeting of the responsible technical committee, which you may attend. If you feel that your comments have not received a fair hearing you should make your views known to the ASTM Committee on Standards, at the address shown below.

This standard is copyrighted by ASTM International, 100 Barr Harbor Drive, PO Box C700, West Conshohocken, PA 19428-2959, United States. Individual reprints (single or multiple copies) of this standard may be obtained by contacting ASTM at the above address or at 610-832-9585 (phone), 610-832-9555 (fax), or service@astm.org (e-mail); or through the ASTM website (www.astm.org).