



Designation: D 5132 – 02

Standard Test Method for Horizontal Burning Rate of Polymeric Materials Used in Occupant Compartments of Motor Vehicles¹

This standard is issued under the fixed designation D 5132; the number immediately following the designation indicates the year of original adoption or, in the case of revision, the year of last revision. A number in parentheses indicates the year of last reapproval. A superscript epsilon (ϵ) indicates an editorial change since the last revision or reapproval.

1. Scope *

1.1 This test method is intended for use as a small-scale laboratory procedure for comparing the relative horizontal burning rates of polymeric materials used in occupant compartments of motor vehicles.

1.2 Units—The values stated in SI units are to be regarded as standard.

1.3 This test method, Federal Safety Standard MVSS 302, SAE J369, and ISO 3795 Standards are technically equivalent.

1.4 This standard is used to measure and describe the response of materials, products, or assemblies to heat and flame under controlled conditions, but does not by itself incorporate all factors required for fire hazards or fire risk assessment of materials, products, or assemblies under actual fire conditions.

1.5 *This standard does not purport to address all of the safety concerns, if any, associated with its use. It is the responsibility of the user of this standard to establish appropriate safety and health practices and determine the applicability of regulatory limitations prior to use.* Specific hazard statements are given in Section 7.

2. Referenced Documents

2.1 ASTM Standards:

D 5025 Specification for Laboratory Burner Used in Small-Scale Burning Tests on Plastic Materials²

E 176 Terminology of Fire Standards³

E 691 Practice for Conducting an Interlaboratory Study to Determine the Precision of a Test Method⁴

2.2 Federal Safety Standard:

MVSS 302 Flammability of Interior Materials—Passenger Cars, Multipurpose Passenger Vehicles, Trucks and Buses⁵

2.3 SAE Standard:

SAE J369 Flammability of Polymeric Interior Materials - Horizontal Test Method⁶

2.4 ISO Standard:

ISO 3795 Road vehicles, and tractors and machinery for agriculture and forestry—Determination of burning behavior of interior materials⁷

3. Terminology

3.1 *Definitions*—For definitions of fire-related terms used in this test method refer to Terminology E 176.

4. Summary of Test Method

4.1 This test method employs a standard test specimen (100 × 356) mm with a thickness up to 13 mm, mounted in a U-shaped metal frame. The specimen is ignited by means of a 38-mm high flame from an appropriate burner, and the burning rate of the material is determined.

4.2 The rate of burning is determined by measurements of the horizontal distance burned in relation to the time of burning, and reported for each set of specimens.

5. Significance and Use

5.1 This test method provides a standard laboratory procedure for measuring and comparing the burning rates of polymeric materials under specified controlled conditions.

5.2 The rate of burning is affected by such factors as density, direction of rise, and type and amount of surface treatments. The thickness of the finished specimens must also be taken into account. These factors must be considered in order to compare materials on the same basis.

5.3 In this procedure, the specimens are subjected to one or more specific sets of laboratory test conditions. If different test conditions are substituted or the end-use conditions are changed, it is not always possible by or from this test method to predict changes in the fire-test-response characteristics measured. Therefore, the results are valid only for the fire test exposure conditions described in this procedure.

¹ This test method is under the jurisdiction of ASTM Committee D20 on Plastics and is the direct responsibility of Subcommittee D20.30 on Thermal Properties.

Current edition approved December 10, 2002. Published February 2003. Originally approved in 1990. Last previous edition approved in 1994 as D 5132 – 93(1994).

² *Annual Book of ASTM Standards*, Vol 08.03.

³ *Annual Book of ASTM Standards*, Vol 04.07.

⁴ *Annual Book of ASTM Standards*, Vol 14.02.

⁵ United States Code of Federal Regulations, 49 CFR 571.302, 36 FR 28991, available from Superintendent of Documents, U.S. Government Printing Office, Washington, DC 20402.

⁶ Available from Society of Automotive Engineers (SAE), 400 Commonwealth Dr., Warrendale, PA 15096-0001.

⁷ Available from International Organization for Standardization (ISO), 1 rue de Varembe, Case postale 56, CH-1211, Geneva 20, Switzerland.

***A Summary of Changes section appears at the end of this standard.**

6. Apparatus

6.1 The apparatus shall be as shown in Figs. 1-6 and shall include the following:

6.1.1 *Test Chamber*—A chamber approximately 380 by 355 by 200 mm constructed of 1.25–1.50 mm steel sheet and fabricated in accordance with Fig. 1.

6.1.2 *Laboratory Burner*—Constructed in accordance with Specification D 5025.

NOTE 1—The burner may be mounted on the door, as shown in Fig. 6, to ensure proper alignment.

6.1.3 *Gas Supply*—Methane or natural gas having a heating value of $37 \pm 1 \text{ MJ/m}^3$ regulated to approximately 20 kPa.

6.1.4 *Specimen Holder Support*—A device capable of maintaining the specimen holder horizontally in place so that the top of the burner tube is positioned 19 mm below the top surface of the bottom U-shaped frame when placed in the specimen holder support, as shown in Fig. 2 and Fig. 3. The base of the support shall not obstruct the ventilation holes in the base of the cabinet.

6.1.5 *Specimen Holder*—Two matching U-shaped frames of noncorroding metal stock 25 mm wide and 10 mm high. The interior dimensions of the U-shaped frames are 50 mm wide by 330 mm long. A specimen that softens and bends at the flaming end so as to cause erratic burning is kept horizontal by supports consisting of thin, heat-resistant wires, spanning the width of the U-shaped frame under the specimen at 25-mm intervals. A device that may be used for supporting this type of material is an additional U-shaped frame containing the specimen, spanned by 0.25-mm wires of heat-resistant composition at 25 mm intervals starting 38 mm from the open end. The device is inserted over the bottom U-shaped frame. See Fig. 4 and Fig. 5.

6.1.6 *Timing Device*—A timer accurate to the nearest 0.1 s.

6.1.7 *Measuring Device*—A rule accurate to the nearest 1.0 mm.

7. Hazards

7.1 During the course of combustion, gases or vapors, or both, are evolved that may be hazardous. Precautions shall be taken to protect the operator.

8. Test Specimens

8.1 A minimum of five specimens 100 ± 5 mm wide by a minimum 300 mm long by thickness up to a maximum of 13.0 mm are prepared by cutting from the test material. If the test material has a coating, covering, or construction that is considered directional in nature, and it has a directional effect on the burning rate, than five specimens are produced by cutting the material for testing of burning rates in both the transverse and longitudinal directions.

8.2 Cut specimens from uniform density samples. The maximum thickness of any specimen shall be 13.0 mm. If any material to be tested exceeds this, it shall be cut to the above thickness by a mechanical process applied to the side which does not face the occupant compartment, so that the specimen shall include the primary surface of the part. In case of materials made of different composition which are not composite materials, all the layers within a depth of 13.0 mm from the surface facing towards the occupant compartment shall be tested individually, as shown at the Fig. 7. Any material that does not adhere to other materials at every point of contact shall be tested separately. Any material that adheres to other materials at every point of contact shall be tested as a composite with other material(s). Record the information on specimen preparation in the test report.

8.3 Where it is not possible to obtain a flat specimen because of the component configuration, cut the specimen to the maximum thickness of 13.0 mm at any point, from the area with the least curvature, and in such a manner as to include the face side.

8.4 The minimum width and length of the specimen shall be 95 and 300 mm, respectively. Use the maximum available

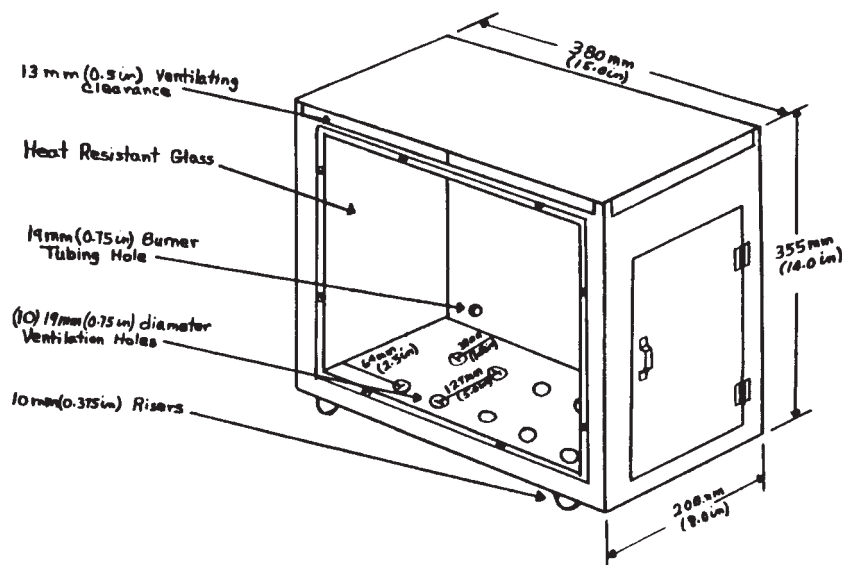

FIG. 1 Horizontal Flammability Chamber

ASTM D 5132 - 02

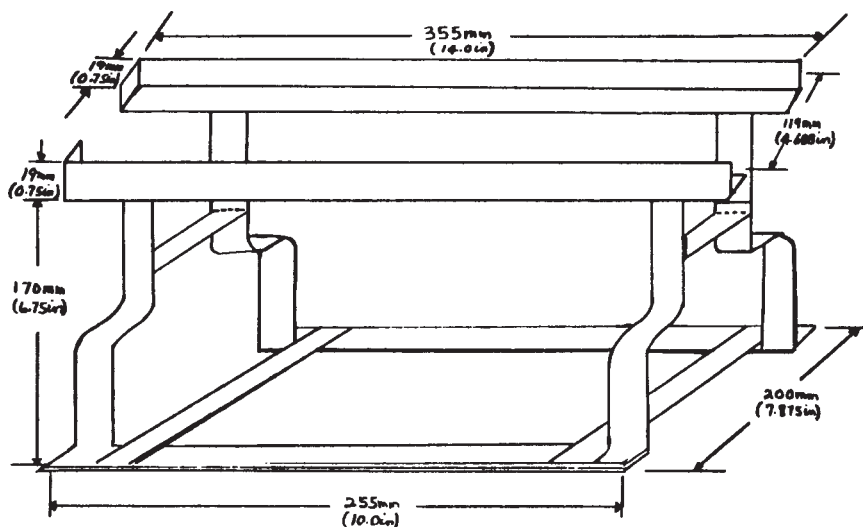

FIG. 2 Typical Specimen Holder Support

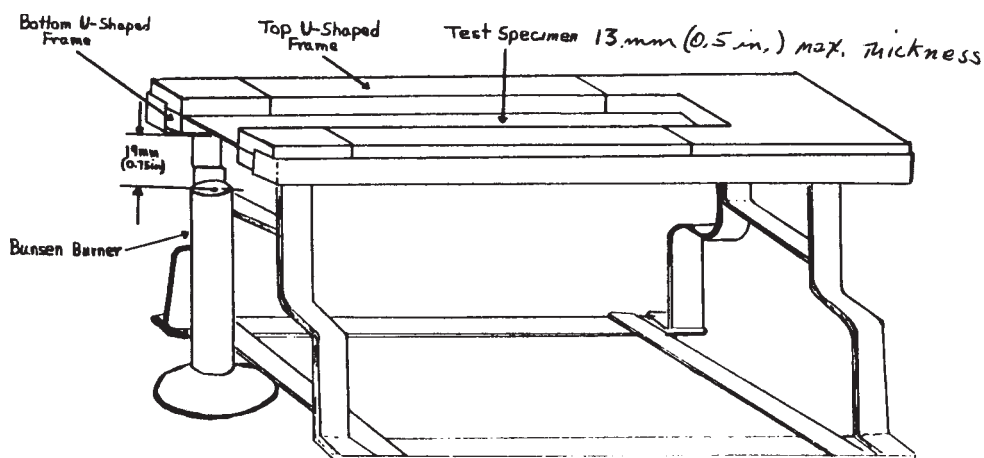

FIG. 3 Specimen Holder With Specimen Positioned in the Specimen Holder Support

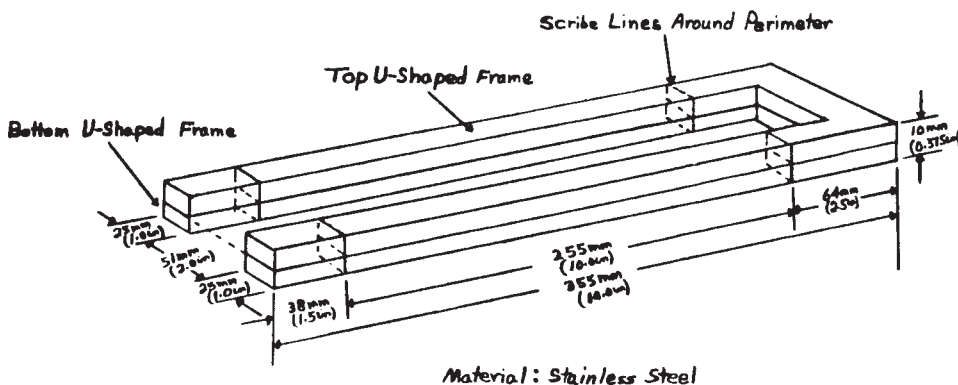

FIG. 4 Typical Specimen Holder—Two Identical U-Shaped Frames

length or width of a specimen (as described in 8.1) where either dimension is less than the specified values.

8.5 For composites, laminates, or surface-treated samples, the side nearest to the compartment occupant should be placed facing down during testing.

8.6 If the material's grain pattern or construction is such that it has a directional effect on the burning rate, testing should be

conducted in both the transverse and longitudinal directions, as in 8.1. Test five specimens in each direction.

9. Conditioning

9.1 Unless otherwise agreed upon, materials shall be conditioned for at least 24 h at $23 \pm 2^\circ\text{C}$ and $50 \pm 5\%$ relative humidity prior to testing.

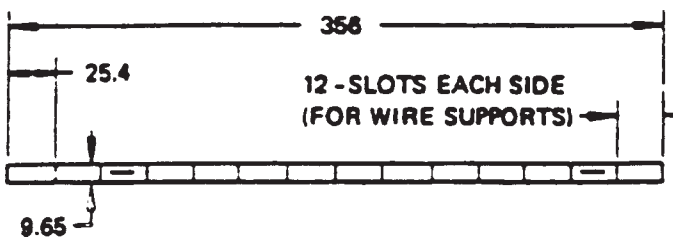
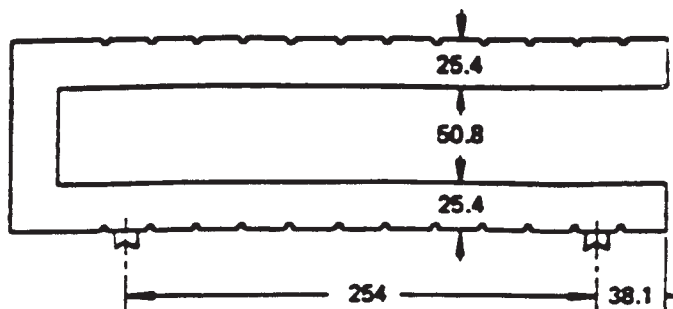

FIG. 5 Bottom U-Frame

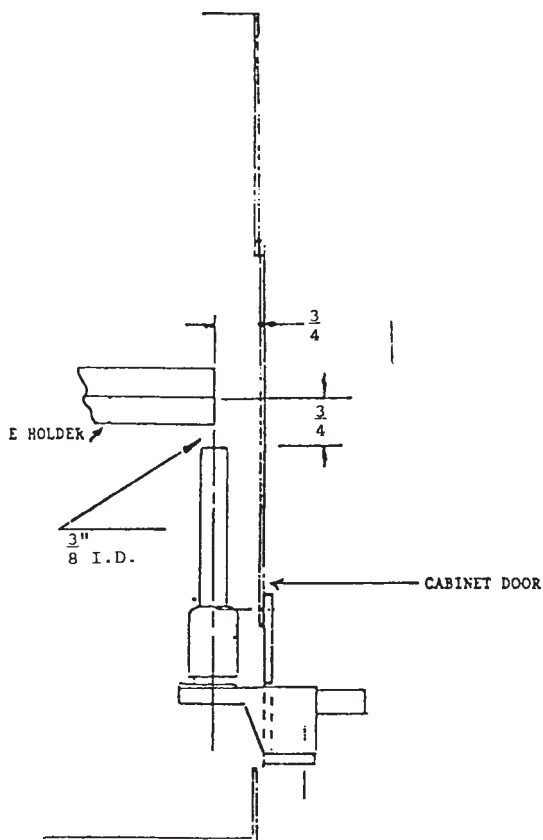

FIG. 6 Burner Position Inside Cabinet

NOTE 2—The proper control of the hood is necessary to ensure the proper draft. Adjust the baffles or the exhaust motor speed, or both, so that the face velocity of the hood shall be constant in the range of 0.1 m/s (75 ft/min). The effectiveness of the hood may change when the door to the lab is opened and closed.

10.2 Place samples with napped or tufted surface on a flat surface and comb twice against the nap using the metal comb at least 110 mm in length, with seven to eight teeth per 25 mm.

10.3 Place the test specimen between the two matching U-shaped frames so that the frames hold both long sides and one end of the specimen.

10.4 Place the burner remote from the specimen, ignite, and adjust it to produce a blue flame 38 ± 2 mm high. Adjust the gas supply and the air ports of the burner until a yellow-tipped blue flame is produced and then increase the air supply until the yellow tip just disappears. Measure the height of the flame, and, if necessary, readjust to obtain a flame 38 mm high.

10.5 Place the burner inside the open end of the test chamber and position the burner to ensure that the center of the burner top is 19 ± 1 mm below the center of the bottom edge of the specimen at the open end of the specimen holder when the specimen is in the specimen testing position.

10.6 Place the mounted specimen in the horizontal testing position in the specimen holder support inside the test chamber.

10.7 Turn on the exhaust hood.

10.8 Move the flame into contact with the specimen for a period of 15 s, then extinguish the exposure flame by turning off the gas supply.

10.9 Observe the leading edge of the flame front, starting the timer when the scribed mark 38 mm from the open end of the sample holder is reached.

10.10 Measure the time it takes the leading edge of the flame front to progress to the line scribed 292 mm from the open end of the top or bottom U-shaped frame. If the flame does not reach this specified end point, time its progress to the furthest distance reached.

11. Calculation

11.1 Calculate the burning rate from the following formula:

$$B = D / T \times 60 \quad (1)$$

where:

- B = burning rate, mm/min,
- D = length the flame traveled, starting from the first scribed line, mm, and
- T = time for the flame to travel distance D , s

12. Report

12.1 Report the following information:

12.1.1 Complete identification of the material tested, including generic description, manufacturer, commercial designation, and lot number, color and other information as requested.

12.1.2 Directionality of the specimens, if pertinent. See 8.1 and 8.5.

12.1.3 The thickness and type of specimens tested, that is, composite, laminate, finished section, cellular foam, etc.

12.1.4 Conditioning treatment.

12.1.5 Any prior treatment before testing, other than cutting, trimming and conditioning.

9.2 All specimens shall be tested in a laboratory atmosphere of 15 to 35°C and 45 to 75 % relative humidity.

10. Procedure

10.1 Place the test chamber inside a laboratory exhaust hood.

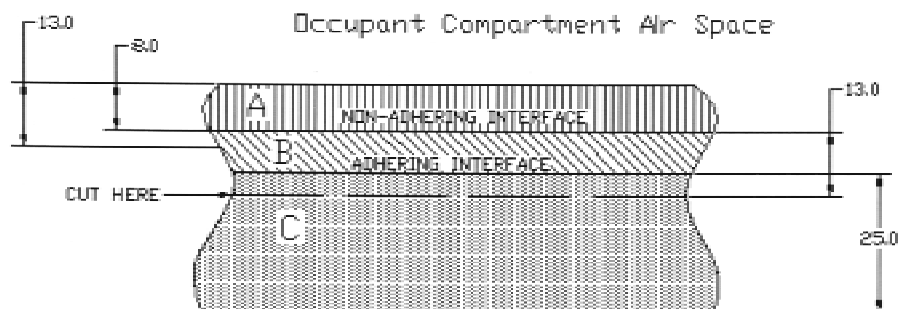

NOTE 1—Material A has a non-adhering interface with material B and is tested separately. Part of material B is within 13.0 mm of the occupant compartment air space, and materials B and C adhere at every point of contact; therefore B and C are tested as a composite. The cut is in material C as shown, to make a specimen 13.0 mm thick.

FIG. 7 Specimen Preparation (Illustrative Example)

- 12.1.6 Number of specimens tested.
- 12.1.7 Burnt distance in mm, and burning time, in seconds.
- 12.1.8 All calculated single values of burning rate, in mm / min.
- 12.1.9 Average burning rate in millimetres per minute when the flame reaches the specific end point. Report *D* and *T* separately for each specimen when the flame propagation stops before reaching the end point.

12.1.10 Describe observations of burning characteristics such as warping, melting, dripping, charring, etc.;

12.2 The report shall contain the following statement: “In this procedure, the specimens are subjected to one or more specific laboratory test conditions. If different test conditions are substituted or the end-use conditions are changed, it may not be possible by or from this test to predict changes in the fire-test-response characteristics measured. Therefore, the results are valid only for the fire test exposure conditions described in this procedure.”

13. Precision and Bias

13.1 *Precision*—The repeatability study was carried out at one laboratory utilizing five polymer materials and by testing ten specimens of each of materials. The repeatability standard deviation has been determined to be 14–36 % (Table 1). Subcommittee D20.30.03 currently is conducting an interlabo-

TABLE 1 Statistical Information

Materials	Average Burn Rate, mm/min.	S_r^A	r^B
Nylon 6, 35% Glass	36.2	5.0	14.0
POM Copolymer	38.1	5.2	14.6
ASA	47.3	4.9	13.6
ABS	43.4	3.9	10.8
Nylon 6, 10% Glass	46.4	16.8	47.0

^A S_r = within-laboratory standard deviation for the indicated material.
^B r = within-laboratory critical interval between two test results = $2.8 \times S_r$.

ratory study to determine the reproducibility of this test method. The results of the study will be available before September 2003.

NOTE 3—**Caution:** The data in the Table 1 should not be applied to acceptance or rejection of the materials and users of this test method should apply the principles outlined in the Practice E 691 to generate data specific to their materials and laboratory.

13.2 *Bias*—No information can be presented on the bias of the procedure in the Test Method as there are no recognized standards that could be used for measuring or calculating of the bias values.

14. Keywords

14.1 burning rate; flame; flexible cellular materials; heat; motor vehicles; occupant compartments; polymeric materials; rubber

APPENDIX

(Nonmandatory Information)

X1. CHARACTERIZATION OF BURNING BEHAVIOR OF MATERIAL—CLASSIFICATION

X1.1 If there are no specific requirements for characterization of the specimen’s burning behavior, it can be classified as follows:

X1.1.1 The material does not support the combustion during or following the 15 s ignition period. Burn rate calculation is not required.

 **D 5132 – 02**

X1.1.2 The material ignites on either surface, but does not transmit a flame front across either surface to the first scribed line. No measurable flame travel. Burn rate calculation is not required.

X1.1.3 The material stops burning during 60 s after start of the timing, and has not burned more than 50 mm from the first scribed line. Burn rate calculation is not required.

X1.1.4 The material has burned more than 50 mm from the first scribed line but stops burning before reaching the second scribed line, or the burn time is 60 s or greater. Report the burn rate.

X1.1.5 The material burns the full distance (254 mm) between scribed lines. Report the burn rate.

X1.1.6 The material transmits a flame across either surface more than 50 mm beyond the first scribed line at a rate too fast to measure accurately; therefore no calculations of the burning rate is required (examples of materials in this category are extremely thin films that burn rapidly, or napped surfaces that “flash”).

X1.2 If no specific burn rate requirements are indicated, a material meets the requirements of the standard if the burn rate does not exceed 100 mm/min or achieves X1.1.1, X1.1.2, or X1.1.3 classification, as specified in X1.1

SUMMARY OF CHANGES

This section identifies the location of selected changes to this test method. For the convenience of the user, Committee D20 has highlighted those changes that may impact the use of this test method. This section may also include descriptions of the changes or reasons for the changes, or both.

D 5132 – 02:

- (1) Changed title and scope of the standard, as the application field of the Standard had been generalized to polymeric materials.
- (2) Modified caveat per new requirements (*Form and Style for ASTM Standards*, November 2000).
- (3) Added statement of equivalency with MVSS302, SAE J369, and ISO 3795 Standards.
- (4) Added new reference documents.

- (5) Standardized on use of SI units.
- (6) Added additional drawing explaining the procedure of specimen preparation.
- (7) Modified report section.
- (8) Added Precision and Bias Statement (Section 13).
- (9) Added Appendix X1.
- (10) Harmonized Standard with MVSS302, SAE J369, and ISO 3795 Standards.

ASTM International takes no position respecting the validity of any patent rights asserted in connection with any item mentioned in this standard. Users of this standard are expressly advised that determination of the validity of any such patent rights, and the risk of infringement of such rights, are entirely their own responsibility.

This standard is subject to revision at any time by the responsible technical committee and must be reviewed every five years and if not revised, either reapproved or withdrawn. Your comments are invited either for revision of this standard or for additional standards and should be addressed to ASTM International Headquarters. Your comments will receive careful consideration at a meeting of the responsible technical committee, which you may attend. If you feel that your comments have not received a fair hearing you should make your views known to the ASTM Committee on Standards, at the address shown below.

This standard is copyrighted by ASTM International, 100 Barr Harbor Drive, PO Box C700, West Conshohocken, PA 19428-2959, United States. Individual reprints (single or multiple copies) of this standard may be obtained by contacting ASTM at the above address or at 610-832-9585 (phone), 610-832-9555 (fax), or service@astm.org (e-mail); or through the ASTM website (www.astm.org).