



## Standard Test Method for Measurement of Hexane Extractable Content of Polyolefins<sup>1</sup>

This standard is issued under the fixed designation D 5227; the number immediately following the designation indicates the year of original adoption or, in the case of revision, the year of last revision. A number in parentheses indicates the year of last reapproval. A superscript epsilon ( $\epsilon$ ) indicates an editorial change since the last revision or reapproval.

### 1. Scope

1.1 This test method describes an extraction/gravimetric procedure for determination of the amount of hexane soluble low molecular weight material present in polyethylene, ethylene-propylene copolymers, and ethylene-vinyl acetate copolymers. This test method is a modification of the Food and Drug Administration (FDA) procedure for determining hexane extractables of polyolefins. This test method is based upon the presumption that the weight of the residue extract present in the solvent is equal to the amount extracted from the film sample and could therefore be quantified by measuring the weight loss of the extracted film, eliminating the complex and time-consuming evaporation process described in 21 CFR 177.1520.

1.2 *This standard does not purport to address all of the safety concerns, if any, associated with its use. It is the responsibility of the user of this standard to establish appropriate safety and health practices and determine the applicability of regulatory limitations prior to use.*

### 2. Referenced Documents

#### 2.1 ASTM Standards:

D 883 Terminology Relating to Plastics<sup>2</sup>

D 1239 Test Method for Resistance of Plastics Fibers to Extraction by Chemicals<sup>2</sup>

D 1600 Terminology for Abbreviated Terms Relating to Plastics<sup>2</sup>

E 131 Terminology Relating to Molecular Spectroscopy<sup>3</sup>

E 380 Practice for Use of the International System of Units (SI) (the Modernized Metric System)<sup>4</sup>

E 691 Practice for Conducting an Interlaboratory Study to Determine the Precision of a Test Method<sup>4</sup>

#### 2.2 Federal Document:<sup>5</sup>

21 CFR 177.1520

### 3. Terminology

3.1 Units, symbols, and abbreviations used in this test method are in accordance with the definitions given in Terminology 883, and Terminology E 131 or Practice E 380.

#### 3.2 Abbreviations:

3.2.1 *EVA*—ethylene-vinyl acetate copolymer.

3.2.2 *LDPE*—low-density polyethylene.

3.2.3 *HDPE*—high-density polyethylene.

3.2.4 *LLDPE*—linear low-density polyethylene.

3.2.5 *FDA*—Food and Drug Administration.

### 4. Summary of Test Method

4.1 Film samples are extracted with hexane for 2 h at  $49.5 \pm 0.5^\circ\text{C}$ , dried, and weighed.

4.2 The loss in weight of the film is presumed to be equal to the extractable content determined by solvent evaporation in the FDA protocol.

### 5. Significance and Use

5.1 FDA requirements for maximum extractables are specified for resin and uses. This test method provides a means to determine the amount of hexane-soluble low molecular weight material present in polyolefins. It is applicable to resins containing greater than 0.20 % extractables.

### 6. Apparatus

6.1 *Water Bath*, maintained at  $49.5 \pm 0.5^\circ\text{C}$ .

6.2 *Resin Kettle*, 1500-mL.<sup>6</sup>

6.3 *Kettle Head*, 3-neck, with one 45/50 and two 24/40 female joints, and appropriate stoppers.<sup>7</sup>

6.4 *Clamp*.<sup>8</sup>

6.5 *Allihn Condenser*, Size C, with 45/50 male joint.<sup>9</sup>

6.6 *Plastic Sleeves*, tetrafluoroethylene (TFE), to fit Allihn condenser 45/50 male joint.

6.7 *Vacuum Oven*, capable of maintaining  $80 \pm 5^\circ\text{C}$  and a minimum of 25-in. Hg pressure.

<sup>1</sup> This test method is under the jurisdiction of ASTM Committee D-20 on Plastics and is the direct responsibility of Subcommittee D20.70 on Analytical Methods.

Current edition approved June 15, 1995. Published August 1995. Originally published as D 5227 – 92. Last previous edition D 5227 – 92.

This edition includes revisions to Section 10, Calculation.

<sup>2</sup> *Annual Book of ASTM Standards*, Vol 08.01.

<sup>3</sup> *Annual Book of ASTM Standards*, Vol 14.01.

<sup>4</sup> *Annual Book of ASTM Standards*, Vol 14.02.

<sup>5</sup> Available from Standardization Documents Order Desk, Bldg. 4 Section D, 700 Robbins Ave., Philadelphia, PA 19111-5094. Attn: NPODS.

<sup>6</sup> Ace Glass, Inc., Cat. No. 6476, Code 15, or its equivalent, has been found satisfactory.

<sup>7</sup> Ace Glass, Inc., Cat. No. 6486, Code 50, or its equivalent, has been found satisfactory.

<sup>8</sup> Ace Glass, Inc., Cat. No. 6496, Code 10, or its equivalent, has been found satisfactory.

<sup>9</sup> Ace Glass, Inc., Cat. No. 6740, Code 06, or its equivalent, has been found satisfactory.

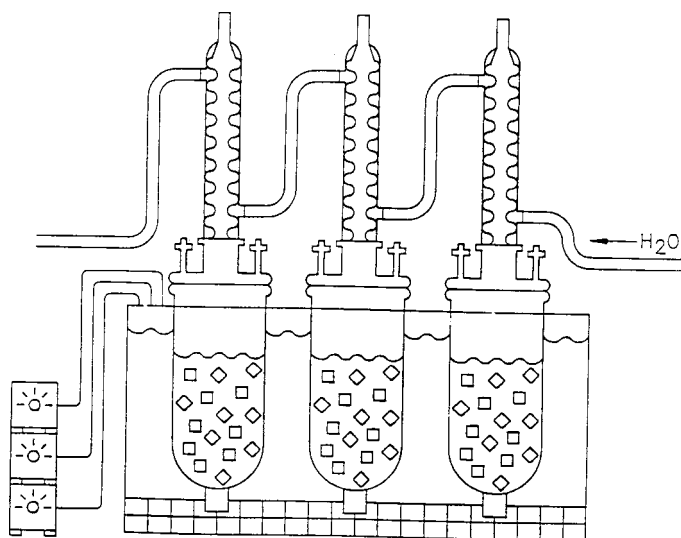

FIG. 1 Resin Kettle Setup

- 6.8 *Magnetic Stirring Bar*, egg-shaped, TFE-coated, 1½ by 5⁄8 in.
- 6.9 *Submersible Magnetic Stirring Motor*, with power supply.<sup>10</sup>
- 6.10 *Analytical Balance*, capable of weighing to 0.1 mg.

**7. Reagents and Materials**

7.1 *n-Hexane*, aromatic free (<1 mg/L), minimum 85 % *n*-Hexane-reagent grade or equivalent.<sup>11</sup> The solvent must be free of aromatic compounds that would significantly increase the solubility of the resin. The solvent grade specified represents the minimum required purity.

**8. Materials**

- 8.1 *Blown Film*, compression molded films, or cast films can be tested.
- 8.2 *Film*, approximately 2.5 g, with a thickness not exceeding 4 mil is required for a single determination.

**9. Procedure**

- 9.1 Assemble the resin kettle setup with glass stopper, clamp, and magnetic stirring bar. (See Fig. 1.)
- 9.2 Add 1000 mL of *n*-Hexane to the kettle assembly.
- 9.3 Stopper the kettle and clamp the assembly into the water bath set at 49.5 ± 0.5°C.

NOTE 1—Temperature is a critical factor in this analysis and must not vary more than 1°C. If the temperature exceeds these limits, the test must be discontinued and restarted. The FDA protocol also states the temperature of the contents must be brought to 49.5 ± 0.5°C within 20 to 25 min.

NOTE 2—The level of water in the bath must be kept at least 2 cm above the level of the solvent in the kettle to ensure the temperature equilibrium. Position the kettle so that the center bottle of the kettle is sitting on a submersible stirrer. Start stirring and allow the hexane to heat for 1 h.

9.4 Using gloves and metal tweezers to avoid sample contamination, cut about 2.7 g of the prepared film sample (4

<sup>10</sup> VWR Scientific Co., Cat. No. 58947-408, or its equivalent, has been found satisfactory.

<sup>11</sup> EM Science, Omnisolv reagent grade, or its equivalent, has been found satisfactory.

mil or less in thickness) into about 1-in. squares using clean sharp scissors.

NOTE 3—Care must be exercised when cutting the samples to avoid ragged edges on the specimen. Small shards of film or contamination present at initial weighing can easily be lost during the test, adversely affecting the test results.

9.5 Weigh 2.5 ± 0.05 g of film squares and record the initial film weight to the nearest 0.1 mg. Also record the number of film pieces.

NOTE 4—Forty or more squares will be obtained depending on the film thickness. Some laboratories have found that a basket assembly, as shown in Appendix X1, eliminates the need to count the film pieces before and after the solvent extraction step.

9.6 Add the film sample to the hexane making sure all squares become immersed in the solvent. (Use tweezers.) Replace the kettle head with condenser column. Extract for 2 h.

9.7 After the extraction period:

9.7.1 Filter the contents of the resin kettle through the fritted porcelain funnel.

9.7.2 Transfer the film squares, using tweezers, to a 200-mL Berzelius beaker and recount the film pieces to verify that none were lost during transfer.

9.7.3 Cover the beaker with a watchglass and place it in a vacuum oven at 80 ± 5°C for 2 h.

9.7.4 After 2 h, remove the covered beaker from the vacuum oven and place it in a desiccator to cool to room temperature (about 1 h).

9.8 Remove the film squares using tweezers and weigh them to the nearest 0.1 mg.

9.9 Repeat 9.7.3 and 9.7.4 until a constant weight is obtained.

**10. Calculation**

10.1 Calculate the weight percent of extractables present in the original sample as follows:

$$\text{hexane extractables, \%} = \frac{(A - B) \times 100 \times 0.935}{A} \quad (1)$$

where:

- A = weight of original sample film, g,
- B = weight of the film after extraction, g, and
- 0.935 = correlation factor to eliminate the bias between the original FDA technique and this alternate test method.

**11. Report**

11.1 Report the hexane extractables to the nearest 0.01 % as calculated in 10.1.

**12. Precision and Bias<sup>12</sup>**

12.1 *Hexane Extractable Content of Polyolefins:*

12.1.1 Table 1 is based on a round robin conducted in 1990 in accordance with Practice E 691, involving five materials tested by ten laboratories. The materials were supplied by one laboratory. Each test result was an individual determination.

<sup>12</sup> Supporting data are available from ASTM Headquarters. Request RR: D20-1173.

**TABLE 1 Hexane Extractable Content of Polyolefins, Weight**

Material	Average	Sr	SR	r	R
HDPE	0.26	0.03	0.05	0.09	0.15
LLDPE	0.88	0.11	0.16	0.31	0.46
LDPE	1.74	0.08	0.15	0.21	0.42
EVA	3.54	0.28	0.33	0.78	0.93
PP	3.80	0.29	0.35	0.81	0.98

Each laboratory obtained six test results for each of the five materials. Each laboratory obtained two test results for each material tested each day for three days.

NOTE 5—**Caution:** The following explanations of *r* and *R* (12.1.2-12.1.2.3) are only intended to present a meaningful way of considering the approximate precision of this test method. The data in Table 1 should not be rigorously applied to acceptance or rejection of material, as those data are specific to the round robin and may not be representative of other lots, conditions, materials, or laboratories. Users of this test method should apply the principles outlined in Practice E 691 to generate data specific to their laboratory and materials, or between specific laboratories. The principles of 12.1.2-12.1.2.3 would then be valid for such data.

12.1.2 *Concept of r and R*—If *Sr* and *SR* have been

calculated from a large enough body of data, and for test results that were averages from testing five specimens.

12.1.2.1 *Repeatability Limit, r*—(Comparing two test results for the same material, obtained by the same operator using the same equipment on the same day.) The two test results should be judged not equivalent if they differ by more than the *r* value for that material.

12.1.2.2 *Reproducibility Limit, R*—(Comparing two test results for the same material, obtained by different operators using different equipment in different laboratories.) The two test results should be judged not equivalent if they differ by more than the *R* value for that material.

12.1.2.3 Any judgment in accordance with 12.1.2.1 or 12.1.2.2 would have an approximate 95 % (0.95) probability of being correct.

12.1.3 *Bias*—There are no recognized standards by which to estimate bias of this test method.

**13. Keywords**

13.1 ethylene-propylene copolymers; ethylene-vinyl acetate copolymers; extractables; FDA; hexane; plastics; polyethylene; solvent extraction

**APPENDIX**

**(Nonmandatory Information)**

**X1. BASKET ASSEMBLY FOR *n*-HEXANE EXTRACTABLES**

X1.1 If one uses the basket assembly shown in Fig. X1.1, the following steps should be performed after the 2-h hexane extraction (9.6):

X1.1.1 Rinse the basket and contents by immersing several times in fresh *n*-hexane contained in a small beaker, allowing the basket to drain between rinsings.

X1.1.2 Remove the excess solvent by briefly blowing the basket with a stream of nitrogen or dry air.

X1.1.3 Place the basket in a vacuum oven for 2 h at 80±5°C, then cool to ambient temperature in a desiccator (about 1 h).

X1.1.4 Reweigh the basket and its contents to the nearest 0.1 mg.

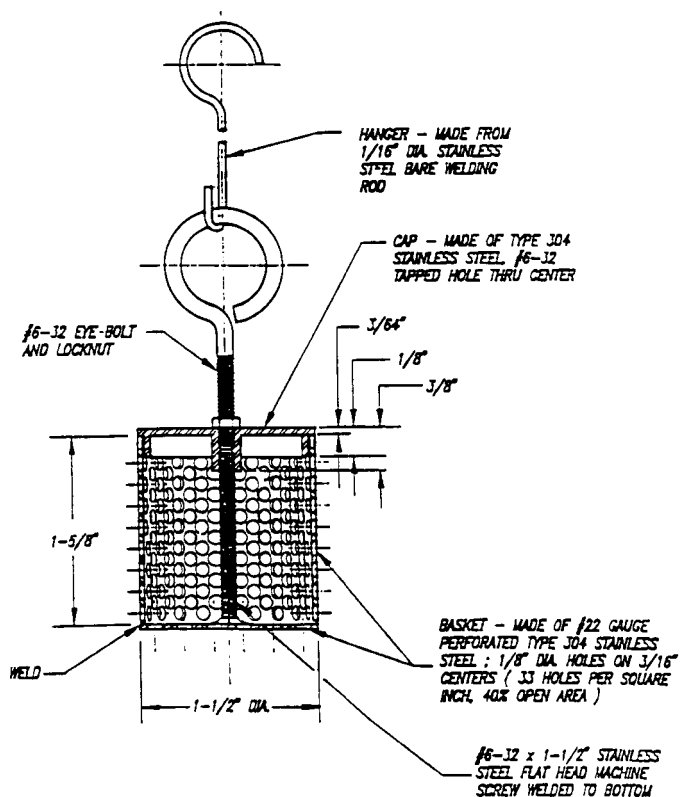

**FIG. X1.1 Basket for *n*-Hexane Extractables**

 **D 5227**

*The American Society for Testing and Materials takes no position respecting the validity of any patent rights asserted in connection with any item mentioned in this standard. Users of this standard are expressly advised that determination of the validity of any such patent rights, and the risk of infringement of such rights, are entirely their own responsibility.*

*This standard is subject to revision at any time by the responsible technical committee and must be reviewed every five years and if not revised, either reapproved or withdrawn. Your comments are invited either for revision of this standard or for additional standards and should be addressed to ASTM Headquarters. Your comments will receive careful consideration at a meeting of the responsible technical committee, which you may attend. If you feel that your comments have not received a fair hearing you should make your views known to the ASTM Committee on Standards, 100 Barr Harbor Drive, West Conshohocken, PA 19428.*