



Standard Test Method for Environmental Stress Crack Resistance (ESCR) of Threaded Plastic Closures¹

This standard is issued under the fixed designation D 5419; the number immediately following the designation indicates the year of original adoption or, in the case of revision, the year of last revision. A number in parentheses indicates the year of last reapproval. A superscript epsilon (ϵ) indicates an editorial change since the last revision or reapproval.

1. Scope

1.1 This test method determines the susceptibility of threaded plastic closures to failure due to environmental stress cracking (ESC).

1.2 Threaded plastic closures in use may contact agents that appreciably reduce the stress at which cracks form. Examples of such agents are: soaps, detergents, oils, and liquid bleaches.

1.3 Other major factors that influence environmental stress crack resistance (ESCR) of threaded plastic closures are the closure material(s), closure design, molded-in stress, and applied stress.

1.4 This procedure applies particularly to closures made from plastics based on polypropylene (PP) or polystyrene (PS). It may also apply to other polymers.

1.5 The values stated in SI units are to be regarded as the standard.

1.6 *This standard does not purport to address all of the safety concerns, if any, associated with its use. It is the responsibility of the user of this standard to establish appropriate safety and health practices and determine the applicability of regulatory limitations prior to use.* Specific precautionary statements are given in Section 8 and Note 2.

NOTE 1—There are no ISO standards covering the primary subject of this test method.

2. Referenced Documents

2.1 ASTM Standards:

D 618 Practice for Conditioning Plastics for Testing²

D 883 Terminology Relating to Plastics²

D 1600 Terminology for Abbreviated Terms Relating to Plastics²

D 2911 Specification for Dimensions and Tolerances for Plastic Bottles³

D 3198 Test Method for Application and Removal Torque of Threaded or Lug-Style Closures³

¹ This test method is under the jurisdiction of ASTM Committee D20 on Plastics and is the direct responsibility of Subcommittee D20.20 on Plastic Products.

Current edition approved July 10, 2003. Published September 2003. Originally approved in 1993. Last previous edition approved in 1995 as D 5419 – 95.

² *Annual Book of ASTM Standards*, Vol 08.01.

³ *Annual Book of ASTM Standards*, Vol 15.09.

E 145 Specification for Gravity-Convection and Forced-Ventilation Ovens⁴

E 691 Practice for Conducting an Interlaboratory Study to Determine the Precision of a Test Method⁴

3. Terminology

3.1 *Definitions*—Except for those terms below, see Terminologies D 883 and D 1600.

3.2 *Definitions of Terms Specific to This Standard:*

3.2.1 *assembly*—closure applied to a bottle finish.

3.2.2 *failure*—during this test, any visible crack.

3.2.2.1 *Discussion*—A crack does not have to penetrate the closure wall to be considered a failure.

3.2.3 *finish*—fixture representing the threaded portion of the bottle.

3.2.4 *threaded closure*—part applied to seal bottle as specified in Specification D 2911.

4. Summary of Test Method

4.1 This test method consists of applying closures at a specified application torque to rigid finishes (of polysulfone or other appropriate resin), immersing the assembly in a potential stress-cracking agent, and observing and reporting time-to-failure.

5. Significance and Use

5.1 This test method compares closures for ESCR. Suitable variables are: closure materials, closure designs, processes, applied torque, and stress-crack agents.

5.2 Results can be used for estimating shelf life of closures in terms of ESCR. This requires that the user has calibrated failure time in this test to failure time in the field for actual packaging systems.

6. Apparatus

6.1 *Wide-Mount Gallon Jars*, glass, PET, or other suitable material. Must have lined closures to ensure air-tight seal. Use one jar per sample.

6.2 *Circulating-Air Oven*, capable of maintaining a temperature of $50 \pm 1^\circ\text{C}$ (critical in this application). See

⁴ *Annual Book of ASTM Standards*, Vol 14.02.

Specification E 145 for a procedure for confirming satisfactory uniformity of temperature within the oven. There is no air-flow requirement in this application. An environmental room with these properties is also suitable.

NOTE 2—**Caution:** A high-temperature safety switch is highly recommended on this oven. Some test liquids can cause extreme pressure to build up upon heating. Under these conditions the test jars may rupture with explosive force. The override cutoff switch should be set to turn off the oven if the test temperature is exceeded by 10°C or more.

6.3 *Tongs*, for sample removal and inspection.

6.4 *Bottle Finishes*, polysulfone or other material of equivalent stiffness and thermal coefficient of expansion, to which closures are applied. May be made by injection molding or by machining rod stock. See Fig. 1 for drawing of typical fixture. Use appropriate size based on closure and bottle specifications.

6.5 *Torque Meter*, with capacity of at least 5 torque Nm, calibrated or verified within the past 12 months.

6.6 *Plastic Test Closures*, lined or unlined closure based on specifications. PP-based closures should be at least 3 weeks old before testing, and PS closures at least 16 h old. This is to ensure that full crystallization has essentially been achieved.

NOTE 3—To convert lbf-in. torque to Nm torque, multiply by 0.113.

7. Reagents and Materials

7.1 *Test Solution*—Use solution for which the closure is intended.

8. Hazards

8.1 Always wear protective equipment appropriate to the product hazard when setting up or inspecting closures. This may include goggles, gloves, and aprons.

9. Test Specimens

9.1 Normal sample size is 20 closures, typical of lots to be tested. It is strongly advisable to run the test in duplicate (two sets of 20) or to sample more than one lot.

9.2 Visually inspect each closure to be tested. Replace any that appear defective or irregular.

10. Conditioning

10.1 *Conditioning*—After aging in accordance with 6.6, condition closures and bottle finishes at $23 \pm 2^\circ\text{C}$ and $50 \pm 5\%$ relative humidity for not less than 40 h prior to test, in accordance with Procedure A of Practice D 618. Condition test solution at $50 \pm 2^\circ\text{C}$ until it reaches $50 \pm 2^\circ\text{C}$ (16 h normally required).

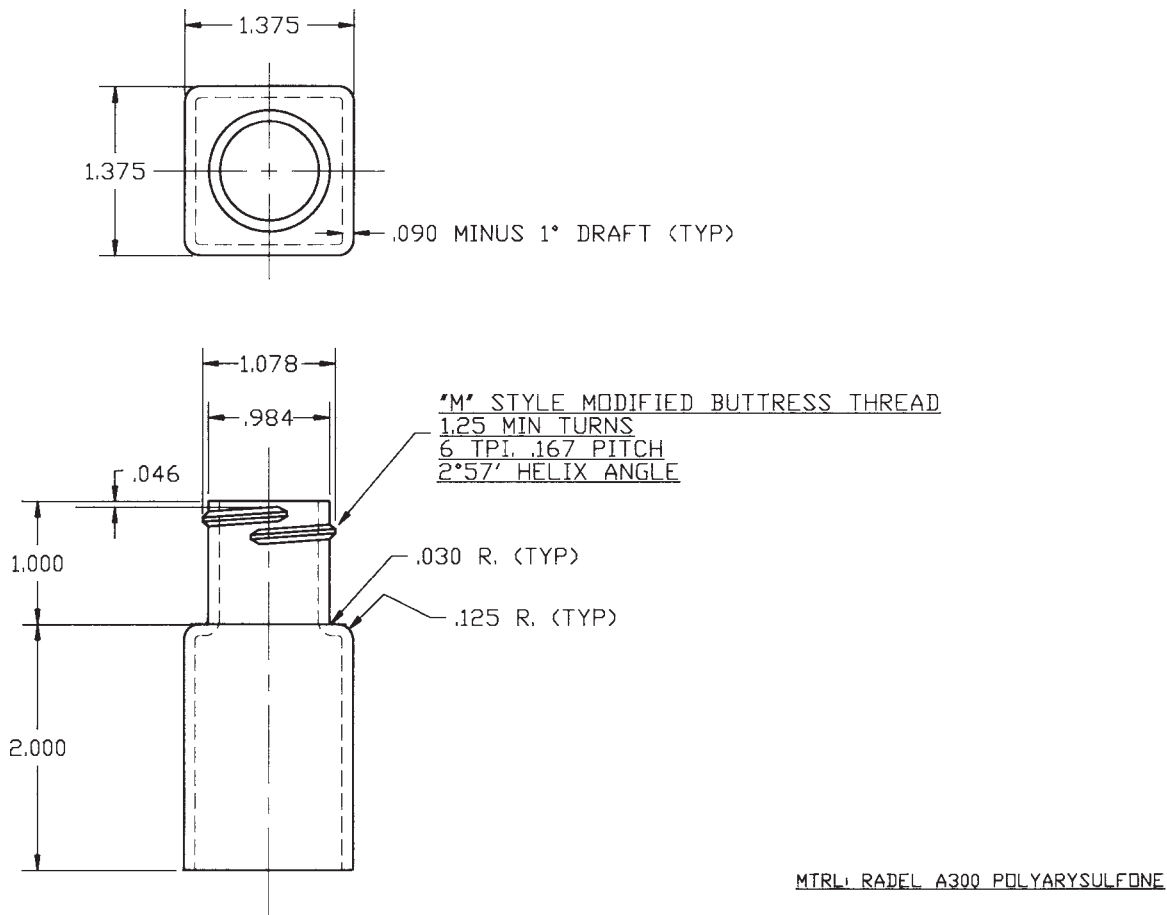

NOTE 1—Tolerances for Dimensions *T*, *E*, and *S* shall be in accordance with Specification D 2911.

FIG. 1 Typical Fixture

10.2 *Test Conditions*—Conduct all tests at $50 \pm 2^\circ\text{C}$, unless instructed otherwise.

11. Procedure

11.1 Apply closures to bottle finishes (see Test Method D 3198). Application torque should be either of the following:

11.1.1 That corresponding to the upper limit of immediate removal torque in production (rule of thumb: application torque = $1.05 \times$ immediate removal torque), or

11.1.2 A nominal value based on the closure diameter (rule of thumb: torque, Nm = closure diameter, mm \times 0.08), or

11.1.3 A value agreed upon between the laboratory and the customer.

11.2 Tolerance for the torque should be $\pm 5\%$.

11.3 Place 20 assemblies in jars. Fill jars with enough test solution at $50 \pm 2^\circ\text{C}$ to cover all assemblies. Wipe any test solution from jar-finish area. Cap jars and hand tighten.

11.4 Place jars on test at $50 \pm 2^\circ\text{C}$. Check temperature of test area daily and maintain within limits. Record the temperature of the oven or room.

11.5 Inspect the assemblies daily except on weekends. Move jars from test condition to inspection area. Do not allow to be off test more than 60 min. Remove the assemblies individually, using tongs on the bottle finishes, not the closures.

NOTE 4—Inspection frequency may be increased during periods of known high-failure rate. Delaying the start of the second duplicate sample facilitates this; however, frequency of torque reapplication should remain at daily except on weekends.

11.6 After inspection, set aside failures. Reapply initial torque to nonfailing closures, return them to jars and move jars back to test condition. Do not remove or loosen closures. If test solution degrades with age, replace it often enough that the failure rate is not significantly reduced. If closure cracks on retorquing, count this as a failure on the next inspection.

11.7 For each failure, note the time, description, and location of failure.

11.8 Any sample (jar) may be taken off test when there have been failures on at least two inspections, and a total of at least 11 out of 20 closures have failed. Record inspections even on days when there are no failures.

NOTE 5—If testing against an F_{50} specification, the test may be terminated if no more than 1 closure out of 20 fails by the specification time.

12. Calculation

12.1 Calculate closures predicted to fail at any given time by the following equation:

$$\text{failures, \%} = [(n - 0.5)/N] \times 100 \quad (1)$$

where:

n = cumulative number of closures that have failed as of the given time, and

N = number of closures tested (20 unless otherwise stated).

12.2 F_{25} Failure Time—Plot the data on Weibull probability graph paper with days on the log scale and percent failure on the probability scale. When more than one closure fails on a given inspection, use the average % failing on that inspection

for the plotting position (see the example in Appendix X1). Draw the best fitting straight line for the plot. The days indicated at the intersection of the data line with the 50 % failure level probability line shall be reported as the F_{50} failure time. See Fig. 2 for example.

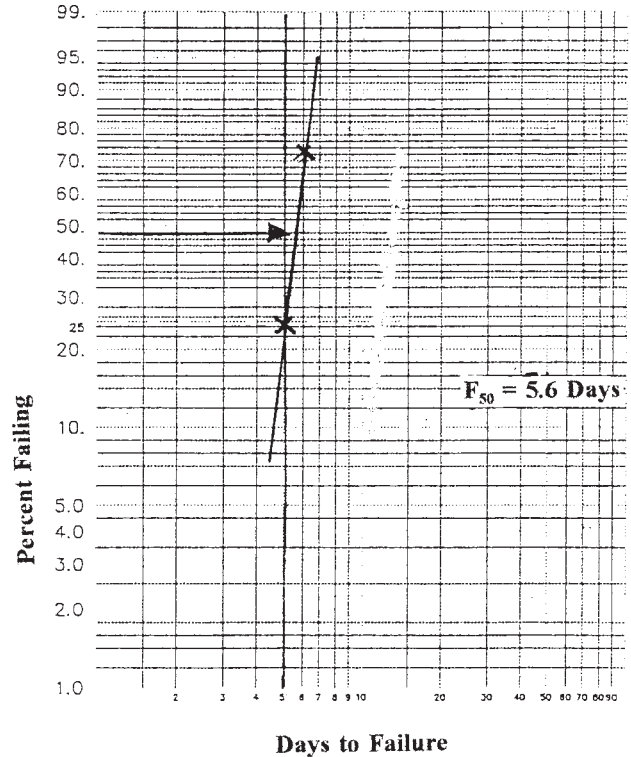

FIG. 2 F_{50} Failure Time

TABLE 1 F_{50} , Days

Thickness or Other Material Condition	Values in units of				
	Average	S_r^A	S_R^B	r^C	R^D
28 mm Polypropylene Tested in Clorox Bleach	5.1	0.8	1.5	2.2	4.1

^A S_r is the within-laboratory standard deviation.

^B S_R is the between-laboratories standard deviation.

^C r is the within-laboratory repeatability limit = $2.8 S_r$.

^D R is the between-laboratory reproducibility limit = $2.8 S_R$.

NOTE 6—The plot or calculations, or both, may be made on computer with suitable software.

13. Report

13.1 Report the following information:

13.1.1 Closure identification, specification number (if applicable), manufacturer, molding location, molding date, lot number, liner description (if applicable), molding machine, resin, mold and cavity number(s), process conditions,

13.1.2 Test solution name and composition/analysis,

13.1.3 Application torque,

13.1.4 Date and time of each inspection and location of each failure, and

13.1.5 Failure time (F_{50}).

14. Precision and Bias ⁵

14.1 *Precision*—Table 1 is based on a round robin conducted in 1995 in accordance with Practice E 691, involving one material tested by 12 laboratories. All of the samples were prepared at one source. Each test result was based on 20 individual determinations. Each laboratory obtained two test results for each material.

NOTE 7—**Caution:** The following explanations of *r* and *R* (14.1.1.1-14.1.1.3) are only intended to present a meaningful way of considering the approximate precision of this test method. The data in Table 1 should not be applied rigorously to the acceptance or rejection of material, as those data are specific to the round robin and may not be representative of other lots, conditions, materials, or laboratories. Users of this test method should apply the principles outlined in Practice E 691 to generate data specific to their laboratory and materials or between specific laboratories. The principles of 14.1.1.1-14.1.1.3 would then be valid for such data.

14.1.1 *Concept of r and R*—if *S_r* and *S_R* have been calculated from a large enough body of data,

⁵ A research report is currently being written.

14.1.1.1 *Repeatability, (r)*—(Comparing two test results for the same material, obtained by the same operator using the same equipment on the same day.) The two test results should be judged not equivalent if they differ by more than the *r* value for that material.

14.1.1.2 *Reproducibility, (R)*—(Comparing two test results for the same material, obtained by different operators using different equipment on different days.) The two test results should be judged not equivalent if they differ by more than the *R* value for that material.

14.1.1.3 Any judgment determined in accordance with 14.1.1.1 and 14.1.1.2 would have an approximate 95 % (0.95) probability of being correct.

14.2 *Bias*—There are no recognized standards by which to estimate the bias of this test method.

15. Keywords

15.1 closures; environmental stress crack resistance (ESCR); failure; plastic; stress crack; threaded plastic closures

APPENDIX

(Nonmandatory Information)

X1. EXAMPLE OF GRAPHICAL DETERMINATION OF *F*₅₀

X1.1 *Data (See Table X1.1):*

X1.2 *Plotting Positions for n = 20 (See Table X1.2):*

X1.3 *X-Axis Values for Example:*

X1.3.1 First failures occurred at 5 days, so the first X value is 5 days.

X1.3.2 The second X value is 6 days.

X1.3.3 The test terminated after 6 days (19 failures).

X1.4 *Y-Axis Values for Example:*

X1.4.1 For the first point, the Y value is the average of the plot position for 1 and 10 closures failed

$$= (2.5 + 47.5)/2 = 25 \% \quad (X1.1)$$

X1.4.2 For the second point, the Y value is the average of the plot position for 11 and 19 closures failed

$$= (52.5 + 92.5)/2 = 72.5 \% \quad (X1.2)$$

TABLE X1.2 Plotting Positions for n = 20

No. of Closures Failed	Plotting Position, %
1	2.5
2	7.5
3	12.5
4	17.5
5	22.5
6	27.5
7	32.5
8	37.5
9	42.5
10	47.5
11	52.5
12	57.5
13	62.5
14	67.5
15	72.5
16	77.5
17	82.5
18	87.5
19	92.5
20	97.5

TABLE X1.1 Data

No. of Days on Test	No. of Closures Failing on This Date	Total No. of Closures Failed to Date
3	0	0
4	0	0
5	10	10
6	9	19

X1.4.3 *Graph (See Fig. 2):*

X1.5 *Determination of *F*₅₀* —Interpolate the line at the “percent failing” value of 50 on the Y-axis, and read of f “days to failure” on the X-axis.

 **D 5419 – 95 (2003)**

ASTM International takes no position respecting the validity of any patent rights asserted in connection with any item mentioned in this standard. Users of this standard are expressly advised that determination of the validity of any such patent rights, and the risk of infringement of such rights, are entirely their own responsibility.

This standard is subject to revision at any time by the responsible technical committee and must be reviewed every five years and if not revised, either reapproved or withdrawn. Your comments are invited either for revision of this standard or for additional standards and should be addressed to ASTM International Headquarters. Your comments will receive careful consideration at a meeting of the responsible technical committee, which you may attend. If you feel that your comments have not received a fair hearing you should make your views known to the ASTM Committee on Standards, at the address shown below.

This standard is copyrighted by ASTM International, 100 Barr Harbor Drive, PO Box C700, West Conshohocken, PA 19428-2959, United States. Individual reprints (single or multiple copies) of this standard may be obtained by contacting ASTM at the above address or at 610-832-9585 (phone), 610-832-9555 (fax), or service@astm.org (e-mail); or through the ASTM website (www.astm.org).