



Designation: D 6110 – 024

Standard Test Methods for Determining the Charpy Impact Resistance of Notched Specimens of Plastics¹

This standard is issued under the fixed designation D 6110; the number immediately following the designation indicates the year of original adoption or, in the case of revision, the year of last revision. A number in parentheses indicates the year of last reapproval. A superscript epsilon (ϵ) indicates an editorial change since the last revision or reapproval.

1. Scope*

1.1 These test methods are method is used to determine the resistance of plastics to breakage by flexural shock as indicated by the energy extracted from standardized (see Note 2) 1) pendulum-type hammers, mounted in standardized machines, in breaking standard specimens with one pendulum swing. These This test methods requires specimens to be made with a milled notch (see Note 3); 2). The notch produces a stress concentration which promotes a brittle, rather than a ductile, fracture. The results of these this test methods are reported in terms of energy absorbed per unit of specimen width (see Note 4); 3).

NOTE 1—This standard resembles ISO 179 1—The machines with pendulum-type hammers have been standardized in that they must comply with certain requirements including a fixed height of hammer fall, which results in a substantially fixed velocity of the hammer at the moment of impact. Hammers of different initial energies (produced by varying their effective weights), however, are recommended for use with specimens of different impact resistance. Moreover, manufacturers of the equipment are permitted to use different lengths and constructions of pendulums with possible differences in pendulum rigidities resulting (see Section 5). Be aware that other differences in machine design do exist.

NOTE 2—The machines with pendulum-type hammers have been specimens are standardized in that they must comply with certain requirements including have a fixed height of hammer fall, which results in a substantially length and fixed velocity of depth, however, the hammer at the moment width of impact. Hammers of different initial energies (produced by varying their effective weights), however, are recommended for use with the specimens is permitted to vary between limits. One design of different impact resistance. Moreover, manufacturers of milled notch is allowed. The notch in the equipment are permitted specimen serves to use different designs concentrate the stress, minimize plastic deformation, and direct the fracture to the part of pendulums, which may result the specimen behind the notch. Scatter in different pendulum rigidities (see Section 5); plus other energy-to-break is thus reduced. Because of differences in machine design, the elastic and viscoelastic properties of plastics, however, response to a given notch varies among materials.

NOTE 3—The specimens are standardized in that they have a fixed length and fixed depth, however, the width of the specimens is permitted to vary between limits. One design of milled notch is allowed. The notch in the specimen serves to concentrate the stress, minimize plastic deformation, and direct the fracture to the part of the specimen behind the notch. Scatter in energy-to-break is thus reduced. Because of differences in the elastic and viscoelastic properties of plastics, however, response to a given notch varies among materials.

NOTE 4—Caution 3—Caution must be exercised in interpreting the results of these this test methods. The following testing parameters may have been shown to affect test results significantly: method of specimen fabrication, including but not limited to processing technology, molding conditions, mold design, and thermal treatment; method of notching; speed of notching tool; design of notching apparatus; quality of the notch; time between notching and test; test specimen thickness; test specimen width under notch; and environmental conditioning.

1.2 This standard does not purport to address all of the safety concerns, if any, associated with its use. It is the responsibility of the user of this standard to establish appropriate safety and health practices and determine the applicability of regulatory limitations prior to use.

NOTE 4—This standard resembles ISO 179 in title only. The content is significantly different.

⁺ These

¹ This test methods are under the jurisdiction of ASTM Committee D20 on Plastics and are the direct responsibility of Subcommittee D20.10 on Mechanical Properties

Current edition approved August 10, 2002; March 1, 2004. Published October 2002; April 2004. Originally published as D 6110 – 97; approved in 1997. Last previous edition approved in 2002 as D 6110 – 9702.

*A Summary of Changes section appears at the end of this standard.

2. Referenced Documents

2.1 ASTM Standards:²

D 618 Practice for Conditioning Plastics for Testing

D 647 Practice for Design of Molds for Test Specimens of Plastic Molding Materials³

D 883 Terminology Relating to Plastics

D 4000 Classification System for Specifying Plastic Materials

D 4066 Classification System for Nylon Injection and Extrusion Materials

D 5942 Test Method for Determination of Charpy Impact Strength

D 5947 Test Methods for Physical Dimensions of Solid Plastics Specimens

E 691 Practice for Conducting an Interlaboratory Test Program to Determine the Precision of Test Methods

3. Terminology

3.1 *Definitions*— For definitions related to plastics, see Terminology D 883.

4. Summary of Test Method

4.1 A notched specimen is supported as a horizontal simple beam and is broken by a single swing of the pendulum with the impact line midway between the supports and directly opposite the notch.

5. Significance and Use

5.1 Before proceeding with ~~these~~ this test methods, refer to the material specification for the material being tested. Any test specimen preparation, conditioning, dimensions and testing parameters required by the materials specification shall take precedence over those required by ~~these~~ this test methods. Table 1 of Classification D 4000 lists the ASTM materials standards that currently exist. If there is no material specification, then the requirements of ~~these~~ this test methods apply.

5.2 The excess energy pendulum impact test indicates the energy to break standard test specimens of specified size under stipulated conditions of specimen mounting, notching (stress concentration), and pendulum velocity at impact.

5.3 ~~For this test method,~~ the energy lost by the pendulum during the breakage of the specimen is the sum of the energies required to initiate fracture of the specimen; to propagate the fracture across the specimen; to throw the free ends of the broken specimen (toss energy); to bend the specimen; to produce vibration in the pendulum arm; to produce vibration or horizontal movement of the machine frame or base; to overcome friction in the pendulum bearing and in the excess energy indicating mechanism, and to overcome windage (pendulum air drag); to indent or deform, plastically, the specimen at the line of impact; and to overcome the friction caused by the rubbing of the striking nose over the face of the bent specimen.

5.4 ~~For relatively brittle materials for which fracture propagation energy is small in comparison with the fracture initiation energy, the indicated impacted energy absorbed is, for all practical purposes, the sum of the energy required to initiate fracture of the specimen, and the toss energy. The toss energy may represent a very large fraction of the total energy absorbed when testing relatively dense and brittle materials.~~

NOTE 5—~~The toss energy, or the energy used to throw the free ends of the broken specimen, is suspected to represent a very large fraction of the total energy absorbed when testing relatively dense and brittle materials. No procedure has been established for estimating the toss energy for the Charpy method.~~

5.5~~4~~ For tough, ductile, fiber-filled, or cloth-laminated materials, the fracture propagation energy ~~may be~~ is usually large compared to the fracture initiation energy. When testing these materials, energy losses due to fracture propagation, vibration, friction between the striking nose and the specimen ~~can~~ has the potential to become quite significant, even when the specimen is accurately machined and positioned, and the machine is in good condition with adequate capacity (see Note 6). ~~B. Significant energy losses due to bending and indentation losses may be appreciable when testing soft materials have also been observed.~~

NOTE 6—Although the frame and the base of the machine should be sufficiently rigid and massive to handle the energies of tough specimens without motion or excessive vibration, the pendulum arm cannot be made very massive because the greater part of its mass must be concentrated near its center of percussion at its striking nose. Locating the striking nose precisely at the center of percussion reduces the vibration of the pendulum arm when used with brittle specimens. Some losses due to pendulum arm vibration (the amount varying with the design of the pendulum) will occur with tough specimens even when the striking nose is properly positioned.

5.6~~5~~ In a well-designed machine of sufficient rigidity and mass the losses due to vibration and friction in the pendulum bearing and in the excess energy indicating mechanism should be very small. Vibrational losses ~~can be quite large~~ are observed when wide specimens of tough materials are tested in machines of insufficient mass, or in machines that are not securely fastened to a heavy base.

~~5.7 With some materials,~~

² For referenced ASTM standards, visit the ASTM website, www.astm.org, or contact ASTM Customer Service at service@astm.org. For *Annual Book of ASTM Standards*, Vol. 08.01, volume information, refer to the standard's Document Summary page on the ASTM website.

³ *Discontinued 1994; Replaced by D 1896, D 3419, D 3641, D 4703, D 5227.*

5.6 ~~Since this test method permits a critical variation in the width of specimen may be found below which specimens will appear ductile, as evidenced by considerable drawing or necking down in the region behind the notch specimens and by since the width dictates, for many materials, whether a relatively high energy absorption, and above which they will appear brittle as brittle, low-energy break (as evidenced by little or no drawing down or necking and by a relatively low energy absorption. Since these test methods permit absorption) or a ductile, high-energy break (as evidenced by considerable drawing or necking down in the width of region behind the specimens notch and since the width dictates, for many materials, whether by a brittle, low-energy break or ductile, high-energy break relatively high energy absorption) will occur, it is necessary that the width be stated in the specification covering that material and that the width be stated along with the impact value.~~

5.8 ~~These~~

5.7 ~~This test methods requires that the specimen breaks completely. For tough Results obtained when testing materials the with a pendulum may that does not have the sufficient energy necessary to complete the breaking of the extreme fibers and toss the broken piece or pieces. Results obtained from unbroken specimens or other types of partially broken specimens pieces shall be considered a departure from standard and should not be reported as a standard result. Impact values cannot be directly compared for any two materials that experience different types of failure.~~

5.98 ~~The value of these this impact test methods lies mainly in the areas of quality control and materials specification. If two groups of specimens of supposedly the same material show significantly different energy absorptions, types of breaks, critical widths, or critical temperatures, it may be assumed is permitted to assume that they were made of different materials or were exposed to different processing or conditioning environments. The fact that a material shows twice the energy absorption of another under these conditions of test does not indicate that this same relationship will exist under another set of test conditions. The order of toughness may be reversed under different testing conditions.~~

6. Apparatus

6.1 *Pendulum Impact Machine*—The machine shall consist of a massive base on which are mounted a pair of supports for holding the specimen and to which is connected, through a rigid frame and bearings, one of a number of pendulum-type hammers having an initial energy suitable for use with the particular specimen to be tested (or one basic pendulum ~~designed to which extra weights may be attached~~), accept add-on weights), plus a pendulum holding and releasing mechanism and a mechanism for indicating the excess energy remaining in the pendulum after breaking specimen. The specimen anvil, pendulum, and frame shall be sufficiently rigid to maintain correct alignment of the striking edge and specimen, both at the moment of impact and during the propagation of the fracture, and to minimize energy losses due to vibration. The base shall be sufficiently massive so that the impact will not cause it to move. The machine shall be designed, constructed, and maintained so that energy losses due to pendulum air drag (windage), friction in the pendulum bearings, and friction and inertia in the excess energy indicating mechanism are held to a minimum.

6.1.1 *Pendulum*—The simple pendulum shall consist of a single or multi-membered arm with a bearing on one end and a head, containing the striking nose, on the other. Although a large proportion of the mass of the pendulum should be concentrated in the head, the arm must be sufficiently rigid to maintain the proper clearances and geometric relationships between the machine parts and the specimen and to minimize vibrational energy losses, which are always included in the measured impact value. A machine with a simple pendulum design is illustrated in Fig. 1. Instruments with a compound-pendulum design also have been found to be acceptable for use. A compound-pendulum design is illustrated in Fig. 2.

6.1.1.1 The machine shall be provided with a basic pendulum capable of delivering an energy of $2.7 \pm 0.14 \text{ J}$ [$2.0 \pm 0.10 \text{ ft-lbf}$]. This pendulum shall be used for specimens that extract less than 85 % of this energy when breaking a specimen. Heavier pendulums or additional weights ~~that can be attached~~ designed to attach to the basic pendulum shall be provided for specimens that require more energy to break. A series of pendulums such that each has twice the energy of the next lighter one has been found convenient.

6.1.1.2 The effective length of the pendulum shall be between 0.325 and 0.406 m [$12.8 \text{ an } 16.0 \text{ in.}$] so that the required elevation of the striking nose ~~may be~~ is obtained by raising the pendulum to an angle between 60 and 30° above the horizontal.

6.1.2 *Striking Edge*— The striking edge (nose) of the pendulum shall be made of hardened steel, tapered to have an included angle of $45 \pm 2^\circ$ and shall be rounded to a radius of $3.17 \pm 0.12 \text{ mm}$ [$0.125 \pm 0.005 \text{ in.}$]. The pendulum shall be aligned in such a way that when it is in its free hanging position, the center of percussion of the pendulum shall lie within $\pm 2.54 \text{ mm}$ [0.10 in.] of the middle of the line of contact made by the striking nose upon the face of a standard specimen of square cross section. The distance from the axis of support to the center of percussion ~~may be~~ is determined experimentally from the period of motion of small amplitude oscillations of the pendulum by means of the following equation:

$$L = (g/4\pi^2) p^2 \tag{1}$$

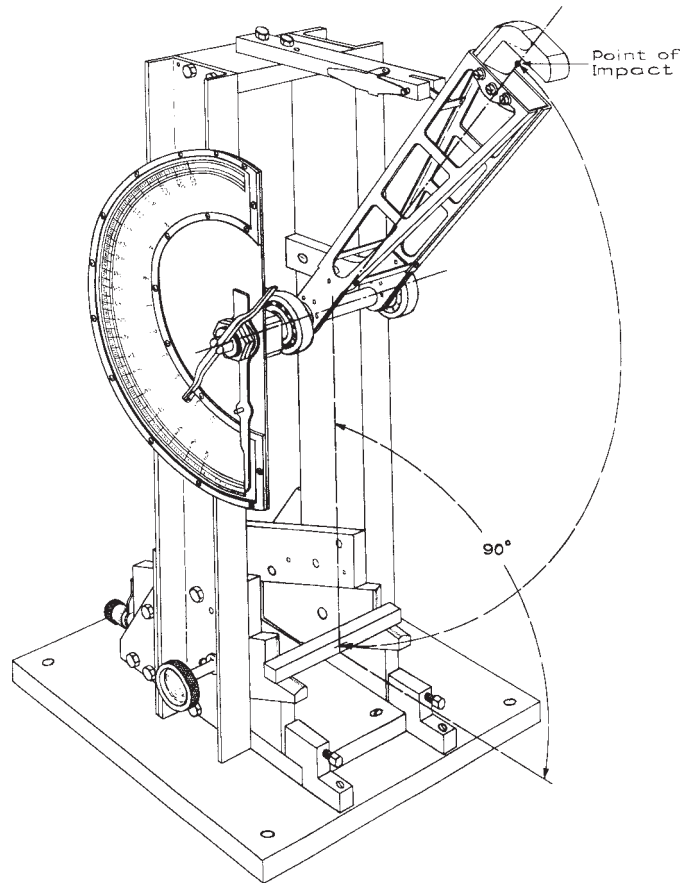

FIG. 1 Simple Beam (Charpy-Type) Impact Machine

where:

L = distance from the axis of support to the center of percussion, m,

g = local gravitational acceleration (known to an accuracy of one part in one thousand), m/s^2

$\pi = 3.1416$ ($4^2 = 39.48$), and

p = period, in s, of a single complete swing (to and fro) determined from at least 20 consecutive and uninterrupted swings. The angle of swing shall be less than 5° each side of center.

6.1.3 *Pendulum Holding and Releasing Mechanism*—The mechanism shall be designed, constructed, and operated so that it will release the pendulum without imparting acceleration or vibration to the pendulum. The position of the pendulum holding and releasing mechanism shall be such that the vertical height of fall of the striking nose shall be 610 ± 2 mm [24.0 ± 0.005 in.]. This will produce a velocity of the striking nose at the moment of impact of approximately 3.46 m [11.4 ft]/s as determined by the following equation:

$$v = \sqrt{2gh} \quad (2)$$

where:

v = velocity of the striking nose at the moment of impact,

g = local gravitational acceleration, and

h = vertical height of fall of the striking nose.

This assumes no windage or friction.

6.1.4 *Specimen Supports*—The test specimen shall be supported against two rigid anvils in such a position that its center of gravity and the center of the notch shall lie on tangent to the arc of travel of the center of percussion of the pendulum drawn at the position of impact. The edges of the anvils shall be rounded to a radius of 3.17 ± 0.12 mm [0.125 ± 0.005 in.] and the anvils' lines of contact (span) with the specimen shall be 101.6 ± 0.5 mm [4.0 ± 0.02 in.] apart (see Fig. 3). A jig for positioning the specimen on the supports should be supplied by the machine manufacturer.

NOTE 7—Some machines currently in use employ a 108.0-mm span. Data obtained under these conditions are valid.⁴

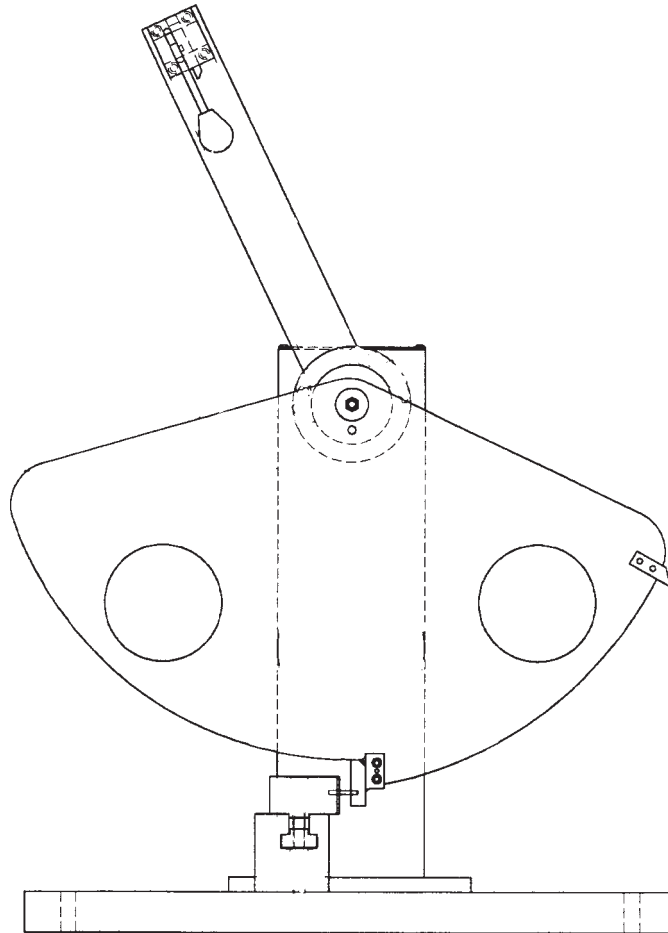

FIG. 2 Example of Compound-Pendulum-Type Machine

6.1.5 *Excess Energy Indicator*—Means shall be provided for determining energy remaining in the pendulum after breaking a specimen. ~~This may consist~~ One acceptable method is the use of a pointer and dial mechanism which indicate the height of rise of the pendulum beyond the point of impact in terms of energy removed from that specific pendulum. ~~Optionally, More modern instruments use an electronic digital display or computer can be used to measure the energy loss and indicate the breaking energy of the specimen.~~ The indicated remaining energy must be corrected for pendulum bearing friction, pointer friction, pointer inertia, and pendulum windage. ~~G The equipment manufacturer should provide graphs or tables to aid in the calculation of the correction friction and windage should be provided by the equipment manufacturer.~~ Instructions for making these corrections are found in Annex A1 and Annex A2. Many digital indicating systems automatically correct for windage and friction. The equipment manufacturer ~~may should~~ be consulted for information on how this is performed.

6.1.6 The calibration procedure in Appendix X2 should be used to establish the accuracy of the equipment. A check of the calibration of an impact machine is difficult to make under dynamic conditions. The basic parameters normally are checked under static conditions. If the machine passes the static tests, then it is assumed to be accurate. Appendix X2, however, also describes a dynamic test for checking certain features of the machine and specimen. For some machine designs, it might be necessary to change the recommended method of obtaining the required calibration measurements. Additional instructions for adjusting a particular machine should be supplied by the manufacturer. Other methods of performing the required checks ~~may be substituted are acceptable provided that they can be shown~~ are proven to result in an equivalent accuracy.

6.2 *Specimen Notching Machine*—Notching shall be done on a milling machine, engine lathe, or other suitable machine tool. A carbide-tipped or industrial diamond-tipped notching cutter is recommended. Both cutter speed and feed rate shall be controllable. Provision for cooling the specimen is recommended. Water and compressed air are suitable coolants for many plastics.

6.2.1 The profile of the cutting tooth or teeth shall be such as to produce a notch in the test specimen of the contour and depth specified in Fig. 4. ~~The included angle of and in the notch shall be $45 \pm 1^\circ$ with a radius of curvature at the apex of 0.25 ± 0.05 mm. The plane bisecting the notch angle shall be perpendicular to the face of the test specimen within 2° .~~ manner specified in Section 8.

⁴ Supporting data is available from ASTM Standards, Vol 08.02: Headquarters. Request Research Report RR: D20-1033.

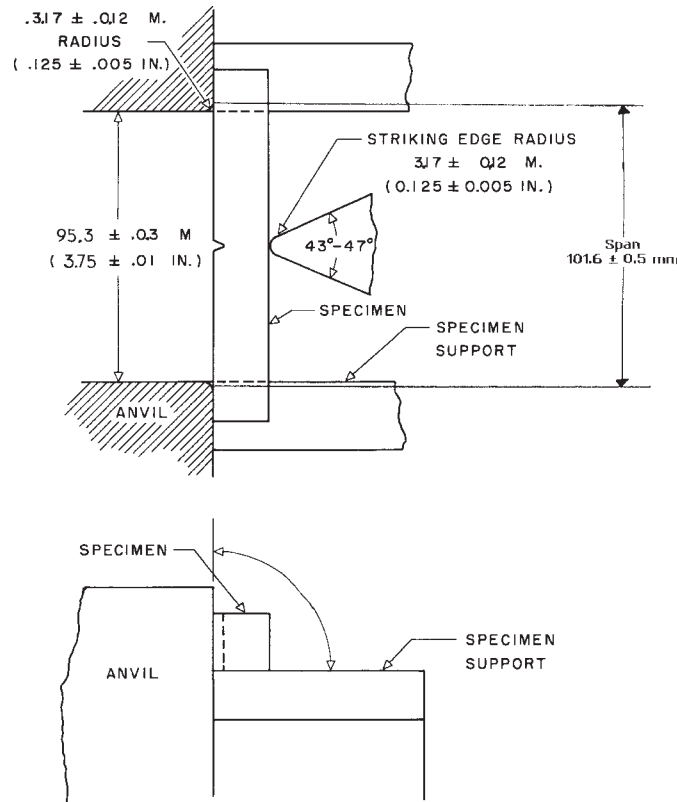

FIG. 3 Relationship of Anvil, Specimen, and Striking Edge to Each Other for Charpy Test Method

6.2.2 A single-tooth cutter shall be used for notching the specimen, unless it is demonstrated that notches of an equivalent quality can be produced with a multi-tooth cutter. Single-tooth cutters are preferred because of the ease of grinding the cutter to the specimen contour and because of the smoother cut on the specimen. The cutting edge shall be ground and honed carefully to ensure sharpness and freedom from nicks and burrs. Tools with no rake and a work relief angle of 15 to 20° have been found satisfactory.

6.3 *Micrometer*—Special micrometer having a contour anvil. *Micrometers*—Apparatus for measurement of $42 \pm 2^\circ$ with a radius the width of curvature at the specimen shall comply with the requirements of 0.13 ± 0.07 mm (see Fig. 5) Test Methods D 5947. Apparatus for measuring the measurement of the depth of plastic material remaining in the specimen under the notch shall comply with requirements of Test Methods D 5947, provided however that the one anvil or presser foot shall be a tapered blade conforming to the dimensions given in Fig. 5. The opposing anvil or presser foot shall be flat and conforming to Test Methods D 5947.

7. Test Specimen

7.1 The test specimen shall conform to the dimensions and geometry of Fig. 4, except as modified in accordance with 7.2-7.5. To ensure the correct contour and conditions of the specified notch, all specimens shall be notched in accordance with Section 8.

7.2 Molded specimens shall have a width between 3.00 and 12.7 mm [0.118 and 0.500 in.]. Use the specimen width as specified in the material specification or as agreed upon as representative of between the cross section in which the particular material may be used. All specimens having one dimension less than 12.7 mm shall have the notch cut on the shorter side. Compression molded specimens shall be notched on the side parallel to the direction of application of molding pressure. The notched surface supplier and the opposite surface may not be parallel in molded specimens due to the draft of the mold, and therefore it is essential that the notched surface be machined parallel to its opposite surface within 0.025 mm, removing a minimum of material in the process, so as to remain within the allowable tolerance for the specimen depth (see Fig. 4)-customer.

7.2.1 The type of mold and molding machine used and the flow behavior in the mold cavity will influence the strength obtained. A It is possible that results from a specimen taken from one end of a molded bar may will give different results than a specimen taken from the other end. Cooperating laboratories should therefore agree on standard molds conforming to Practice D 647, and upon a standard molding procedure for the material under investigation.

7.2.2 A critical investigation of the mechanics of impact testing has shown that tests made upon specimens under 6.35 mm [0.250 in.] in width absorb more energy due to crushing, bending, and twisting than do wider specimens. Specimens 6.35 mm [0.250 in.] or over in width are therefore recommended. The responsibility for determining the minimum specimen width shall be the investigator's, with due reference to the specification for that material.

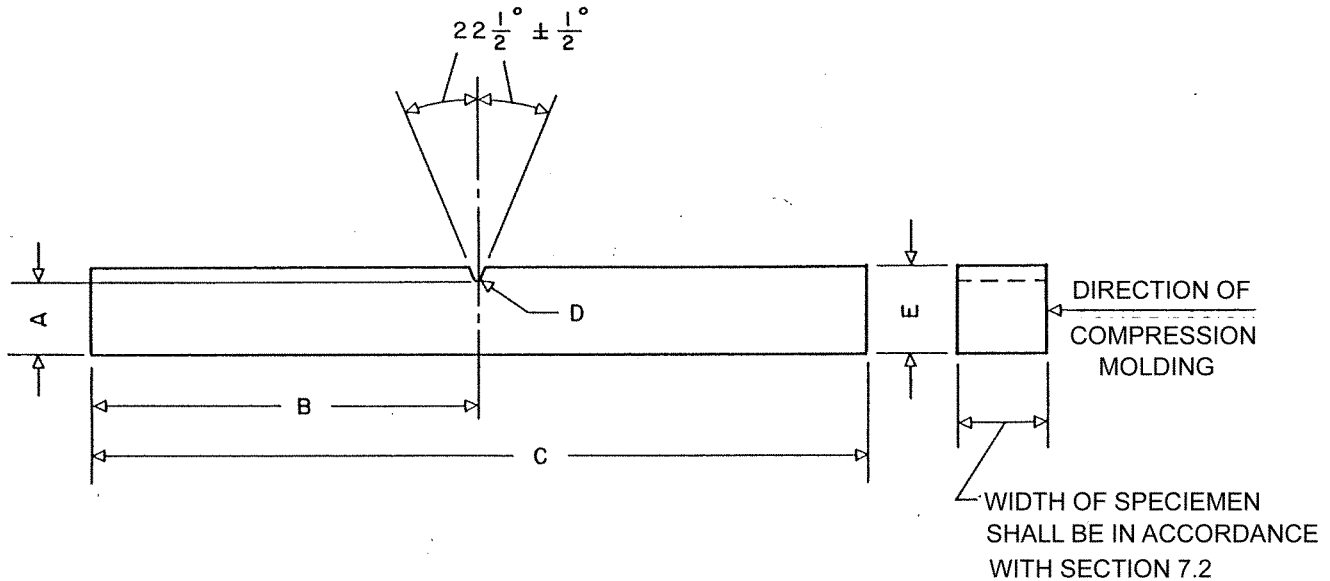

A	10.16 ± 0.05	0.400 ± 0.002
B	63.5 max 61.0 min	2.50 max 2.40 min
C	127.0 max 124.5 min	5.00 min 4.90 min
D	0.25R ± 0.05	0.010R ± 0.002
E	12.70 ± 0.15	0.500 ± 0.006

FIG. 4 Dimensions of Simple Beam, Charpy Type, Impact Test Specimen

7.2.3 The impact resistance of a plastic material may will be different if the notch is perpendicular to, rather than parallel to, the direction of molding.

7.3 For sheet materials, the specimens shall be cut from the sheet in both the lengthwise and crosswise directions unless otherwise specified. The width of the specimen shall be the thickness of the sheet if the sheet thickness is between 3.00 and 12.7 mm [0.118 and 0.500 in.]. Sheet material thicker than 12.7 mm [0.500 in.] shall be machined down to 12.7 mm [0.500 in.]. It is acceptable to test specimens with a 12.7-mm [0.500-in.] square cross section may be tested either edgewise or flatwise as cut from the sheet. When specimens are tested flatwise, the notch shall be made on the machined surface if the specimen is machined on one face only. When the specimen is cut from a thick sheet, notation shall be made of the portion of the thickness of the sheet from which the specimen was cut, for example, center, top, or bottom surface.

7.3.1 The impact resistance of a plastic material may will be different if the notch is perpendicular to, rather than parallel to, the grain of an anisotropic bar cut from a sheet. Specimens cut from sheets that are suspected of being anisotropic shall be prepared and tested both lengthwise and crosswise to the direction of the anisotropy.

7.4 The practice of cementing, bolting, clamping, or otherwise combining specimens of substandard width to form a composite test specimen is not recommended and should be avoided since test results may will be seriously affected by interface effects or effects of solvents and cements on energy absorption of composite test specimens, or both. If Charpy test data on such thin materials are required, however, and if possible sources of error are recognized and acceptable, the following technique of preparing composites may ought to be utilized. The test specimens shall be a composite of individual thin specimens totaling 6.35 to 12.7 mm [0.125 to 0.500 in.] in width. Individual members of the composite shall be aligned accurately with each other and clamped, bolted, or cemented together. Care must be taken to select a solvent or adhesive that will not affect the impact resistance of the material under test. If solvents or solvent-containing adhesives are employed, a conditioning procedure shall be established to ensure complete removal of the solvent prior to test. The composite specimens shall be machined to proper dimensions and then notched. In all such cases, the use of composite specimens shall be noted in the report of test results.

7.5 Each specimen shall be free of twist and shall be bounded by mutually perpendicular pairs of plane, paralleled surfaces and free from scratches, pits, and sink marks. The specimens shall be checked for conformity with these requirements by visual observation against straight edges, squares or flat plates, and by measuring with micrometer calipers. Any specimen showing observable or measurable departure from one or more of these requirements shall be rejected or machined to the proper size and shape before testing. A specimen that has a slight twist to its notched face of 0.05 mm [0.002 in.] at the point of contact with the pendulum striking edge will be likely to have a characteristic fracture surface with considerable greater fracture area than for a normal break. In this case, the energy to break and toss the broken section will be considerably larger (20 to 30 %) than for a normal break.

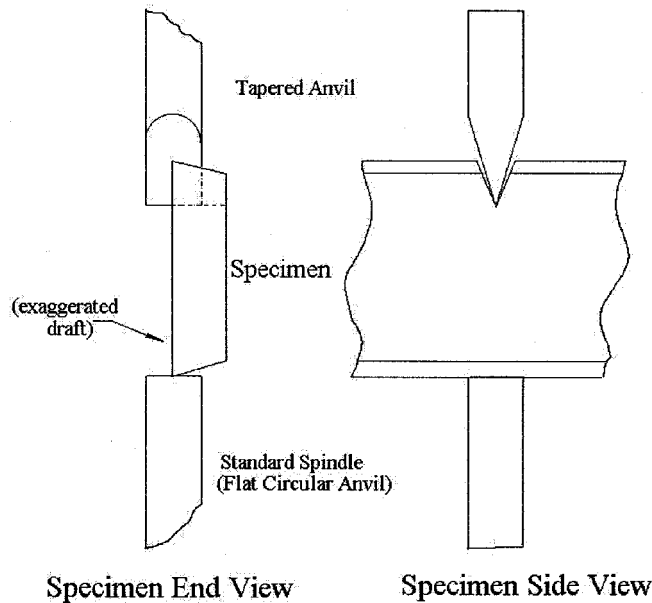

FIG. 5 Notch Depth Measurement on Test Specimens

8. Notching Test Specimens

NOTE 8—When testing a material for the first time, it is necessary to study the effect of all variations in the notching conditions, including cutter dimensions, notch depth, cutter speed, and feed rate. To establish that the notching parameters are suitable, it is advisable to notch several specimens of the material and inspect both the tool entrance and tool exit side of each notched specimen, in accordance with Appendix X1. Adjust the notching machine as required. The specimens used to determine notching conditions shall not be used to make determinations of impact resistance.

8.1 *Notch Dimensions*— The included angle of the notch shall be $45 \pm 1^\circ$ with a radius of curvature at the apex of 0.25 ± 0.05 mm [0.010 ± 0.002 in.]. The plane bisecting the notch angle shall be perpendicular to the face of the test specimen within 2° .

8.1.1 The notch is a critical factor of this test. It is extremely important, therefore, that dimensions of the notch in the specimen are verified. There is evidence that the contour of notches cut in materials of widely differing physical properties by the same cutter will differ. It may be is sometimes necessary to alter the cutter dimensions in order to produce the required notch contour for certain materials.

8.1.2 Both the notch and the cutter used to make the notch shall be inspected, at a minimum, after every 500 notches. The specimen used to verify the notch shall be the same material that is being prepared for testing. Follow the procedure in Appendix X1 when inspecting and verifying the notch in the specimen. If the angle or radius of the notch does not meet the requirements of 8.1, the cutter should be replaced.

NOTE 9—The contour of the notch made using multi-tooth cutters may be is checked by measuring the contour of the notch on a strip of soft metal that is inserted between two specimens during the notching process.

NOTE 10—When the same material is being tested on a repetitive basis, and it can be shown is demonstrated that the notch in the specimen takes the contour of the tip of the cutter and that the notch meets the contour requirements when checked in accordance with Appendix X1, then it is acceptable to check the contour of the tip of the cutter may be checked instead of the notch in the specimen.

8.2 *Notch Depth*— The depth of the plastic material remaining in the bar specimen under the notch shall be 10.216 ± 0.05 mm [0.400 ± 0.002 in.]. This dimension shall be measured with a special micrometer having a contour anvil of $42 \pm 2^\circ$ apparatus in accordance with a radius of curvature at 6.3. The tapered blade will be fitted to the a notch. The specimen will be approximately vertical between the anvils. Position the edge of 0.13 ± 0.07 mm (see Fig. 5). the non-cavity (wider edge) surface centered on the micrometer's flat circular anvil.

8.3 *Cutter Speed and Feed Rate* —The cutter speed and feed speed should be selected based on the material being tested. The quality of the notch may will be adversely affected by thermal deformations and stresses induced during the cutting operation if proper conditions are not selected.⁵ The notching parameters used shall not alter the physical state of the material, such as by raising the temperature of a thermoplastic above its glass transition temperature.

8.3.1 In general, high cutter speeds, slow feed rates, and lack of coolant induce more thermal damage than a slow cutter speed, fast feed speed, and the use of a coolant. Too high a feed speed/cutter speed ratio, however, may has been shown to cause impacting and cracking of the specimen. The range of cutter speed/feed ratios possible to produce acceptable notches can has been shown to be extended by the use of a suitable coolant.

⁵ Discontinued; see 1997 Annual Book of

⁵ Supporting data is available from ASTM Standards, Vol 08.03: Headquarters. Request Research Report RR: D20-1066.

8.3.1.1 For some thermoplastics, suitable notches have been produced using cutter speeds from 54 to 150 m/min and a feed rate of 89 to 160 mm/min without a water coolant. Satisfactory notches also have been produced using the same cutter speeds at feed speeds of from 36 to 160 mm/min with water coolant.

8.3.1.2 Embedded thermocouples ~~can be~~ have been used to determine the temperature rise in the material near the apex of the notch during machining. Thermal stresses induced during the notching operation ~~can be~~ have been observed in transparent materials by viewing the specimen at low magnification between crossed polars in monochromatic light. The specimens used to determine temperature rise shall not be used to make determinations of impact resistance.

8.3.2 The feed rate and the cutter speed shall remain constant throughout the notching operation.

~~8.4 Specimens may be notched separately~~

8.4 It is acceptable to notch specimens individually or in a group. In either case, however, an unnotched backup or dummy bar shall be placed behind the last specimen in the sample holder to prevent distortion and chipping by the cutter as it exits from the last test specimen.

8.5 All specimens having one dimension less than 12.7 mm [0.500 in.] shall have the notch cut on the shorter side. Compression molded specimens shall be notched on the side parallel to the direction of application of molding pressure. The impact resistance of a plastic material ~~may~~ will be different if the notch is perpendicular to rather than parallel to the direction of molding, as with or across the grain of an anisotropic bar cut from a plate.

9. Conditioning

9.1 Check the materials specification for the material that is being tested. If there are no conditioning requirements stated by the materials specification, the test specimens shall be conditioned at $23 \pm 2^\circ\text{C}$ [$73 \pm 3.6^\circ\text{F}$] and $50 \pm 5\%$ relative humidity for not less than 40 h after notching and prior to testing in accordance with Procedure A of Practice D 618. ~~unless it can be~~ documented (between supplier and customer) that shorter conditioning time is sufficient for a given material to reach equilibrium of impact resistance.

9.2 For hygroscopic materials, such as nylons, the material specifications (for example, ~~Spec Classification System~~ D 4066) call for testing dry-as-molded specimens. Such requirements take precedence over the above routine preconditioning to 50 % relative humidity. These specimens shall be sealed in water vapor-impermeable containers as soon as molded. When notching these specimens, minimize the exposure time during notching and return the specimens to a dry container after notching to allow for full cooling of the specimens prior to testing.

9.3 *Test Conditions*—Conduct tests in the standard laboratory atmosphere of $23 \pm 2^\circ\text{C}$ [$73 \pm 3.6^\circ\text{F}$] and $50 \pm 5\%$ relative humidity, unless otherwise specified. In cases of disagreement, the tolerances shall be $\pm 1^\circ\text{C}$ and $\pm 2\%$ relative humidity.

10. Procedure

10.1 Specimen Preparation:

10.1.1 Prepare the test specimens in accordance with the procedures in Section 7. At least five and preferably ten or more individual determinations of impact resistance shall be made to determine the average impact resistance for a particular sample. The specimens shall be of nominal width only.

10.1.2 Notch the specimens in accordance with the procedure in Section 8.

10.1.3 Condition the specimens in accordance with the materials specification for the material that is being tested. If there are no conditioning requirements detailed in the materials specification, follow the conditioning requirements in Section 9.

10.2 Machine Preparation:

10.2.1 Estimate the breaking energy for the sample and select a pendulum of suitable energy. Select the lightest standard pendulum that is expected to break all specimens in the group with an energy loss of not more than 85 % of its capacity (see 6.1). If the breaking energy cannot be estimated, ~~trial runs can be made to determine~~ the correct pendulum can be determined by performing trial runs. Caution should be used to avoid damaging the pendulum by selecting a pendulum that is too light for a particular ~~sample as damage may occur to the pendulum sample~~.

NOTE 11—Ideally, an impact test would be conducted at a constant test velocity. In a pendulum-type test, however, the velocity decreases as the fracture progresses. For specimens that have an impact energy approaching the capacity of the pendulum, there is insufficient energy to complete the break and toss. By avoiding the higher 15 % scale energy readings, the velocity of the pendulum will not be reduced below 1.33 m/s. On the other hand, the use of a pendulum that is too heavy would reduce the sensitivity of the reading.

10.2.2 After installing the selected pendulum on the machine, check the machine for conformity with the requirements of Section 6 before starting the tests.

10.2.3 When using a machine equipped with a pointer and dial mechanism or an electronic indicator that does not automatically correct for windage and friction, determine the windage and friction correction factors for the machine before testing specimens. Windage and friction correction factors shall be determined on a daily basis and shall be calculated each time weights are added to the pendulum or the pendulum is changed. Refer to Annex A1 for information on constructing windage and friction correction charts or refer to Annex A2 for a procedure to calculate the windage and friction correction. If excessive friction is indicated (see X2.12 and X2.13) the machine shall be adjusted before testing specimens. Follow the machine manufacturer's instructions to correct for excessive windage and friction.

NOTE 12—The actual correction factors for windage and friction will be smaller than these factors in an actual test because the energy absorbed by

the specimen prevents the pendulum from making a full swing. The indicated breaking energy of the specimen, therefore, must be included in the calculation of the machine correction.

10.2.4 Some machines equipped with an electronic digital display or computer may automatically compensate for windage and friction.

10.3 Specimen Testing:

10.3.1 Check all of the specimens in the sample group for conformity with the requirements of Sections 7 and 8 and 10.1.

10.3.2 Measure and record the width of each specimen after notching to the nearest 0.025 mm [0.001 in]. Measure the width in one location adjacent to the region notch centered about the anticipated fracture plane.

10.3.3 Measure and record the depth of material remaining in the specimen under the notch with a micrometer caliper of each specimen to the nearest 0.025 mm and record its average width along with its identifying markings, if any.

10.3.2 Position [0.001 in]. The tapered blade will be fitted to the notch. The specimen will be approximately vertical between the anvils. Position the edge of the non-cavity (wider edge) surface so that it is centered on the micrometer's flat circular anvil. See Fig. 5.

10.3.4 Position a test specimen horizontally on the supports and against the anvils so that it will be impacted on the face opposite the notch (see Fig. 3). The notch should be centered between the anvils. A centering jig is useful for this purpose.

10.3.35 Raise and secure the pendulum in the release mechanism. Zero the excess energy indicating mechanism.

10.3.46 Release the pendulum, allowing the striking edge of the pendulum to impact the specimen. Note the indicated breaking energy.

10.3.57 Calculate the net breaking energy (see 11.1). If the net breaking energy is greater than 85 % of the pendulum's nominal energy, the wrong pendulum was used. Discard the result. Select and install a pendulum with a greater available energy or add additional weight to the pendulum, determine the windage and friction correction factor, and repeat the test on a new specimen.

10.3.68 If the proper pendulum was used, test the remaining specimens as described in 10.3.1-10.3.46. Results from specimens that do not break should be discarded. A specimen that does not break completely into two or more pieces is not considered to be broken.

10.3.79 After all of the specimens for the sample have been tested, calculate the impact resistance, in joules per metre, for each individual specimen (see 11.2).

10.3.810 Calculate the average impact resistance for the group of specimens (see 11.3). Values obtained from specimens that did not break completely shall not be included in the average.

10.3.911 Calculate the standard deviation for the group of specimens (see 11.4).

11. Calculation

11.1 *Net Breaking Energy*—Subtract the windage and friction loss energy from the indicated breaking energy.

11.2 *Impact Resistance*—Divide the net breaking energy by the measured width of each individual specimen.

11.3 Calculate the average impact resistance for a group of specimens by adding the individual impact resistance values for the group and dividing the sum by the total number of specimens in the group.

11.4 Calculate the standard deviation as follows and report it to two significant figures:

$$s = \sqrt{(\sum X^2 - n \bar{X}^2)/(n - 1)} \quad (3)$$

where:

s = estimated standard deviation,

X = value of single observation,

n = number of observations, and

\bar{X} = arithmetic mean of the set of observations.

12. Report

12.1 Report the following information:

12.1.1 Complete identification of the material tested, including type source, manufacturer's code number, and previous history.

12.1.2 A statement of how the specimens were prepared, the testing conditions used, the number of hours the specimens were conditioned after notching, and for sheet materials, the direction of testing with respect to anisotropy, if any.

12.1.3 The capacity of the pendulum, J.

12.1.4 The span.

12.1.5 The width and depth under the notch of each specimen tested.

12.1.6 The total number of specimens tested per sample of material (that is five, ten, or more).

12.1.7 The average impact resistance, J/m. Impact resistance is not to be reported for other than complete breaks. ~~Optional units of Reporting results in kJ/m² also may need to be reported is optional~~ (see Appendix X4).

12.1.8 The standard deviation of the values of the impact resistance of the specimens in 10.3.911.

13. Precision and Bias

13.1 Table 1 is based on a round robin⁶ conducted in 1987 in accordance with Practice E 691, involving five materials tested by nine laboratories. For each material, all samples were prepared at one source, but the individual specimens were notched and conditioned at the laboratories which tested them. Each laboratory tested an average of nine specimens for each material.

~~NOTE 13—~~**Caution: material. Warning—**The explanations of r and R (13.2-13.2.3) are intended only to present a meaningful way of considering the approximate precision of this test method. The data presented in Table 1 should not be applied to acceptance or rejection of materials, as these data apply only to the materials tested in the round robin and are unlikely to be rigorously representative of other lots, formulations, conditions, materials, or laboratories. Users of ~~these~~ this test methods should apply the principles outlined in Practice E 691 to generate data specific to their materials and laboratory, or between specific laboratories. The principles of 13.2-13.2.3 would then be valid for such data.

13.2 *Concept of r and R in Table 1*—If S_r and S_R have been calculated from a large enough body of data, and for test results that were averages from testing nine specimens for each test result, then:

13.2.1 *Repeatability*— r is the interval representing the critical difference between two test results for the same material, obtained by the same operator using the same equipment on the same day in the same laboratory. Two tests results shall be judged not equivalent if they differ by more than the r value for that material.

13.2.2 *Reproducibility*— R is the interval representing the critical difference between two test results for the same material, obtained by different operators using different equipment in different laboratories, not necessarily on the same day. Two test results shall be judged not equivalent if they differ by more than the R value for that material.

13.2.3 Any judgement in accordance with 13.2.1 or 13.2.2 would have an approximate 95 % (0.95) probability of being correct.

13.3 There are no recognized standards by which to estimate bias of ~~these~~ this test methods.

14. Keywords

14.1 Charpy impact; impact resistance; notch sensitivity; notched specimen

Annual Book of

⁶ Supporting data is available from ASTM Standards, Vol 14.02: Headquarters. Request Research Report RR: D20-1041 and 1134.

ANNEXES

(Mandatory Information)

A1. INSTRUCTIONS FOR THE CONSTRUCTION OF A WINDAGE AND FRICTION CORRECTION CHART

A1.1 The construction and use of the chart herein described is based upon the assumption that the friction and windage losses are proportional to the angle through which these loss torques are applied to the pendulum. Fig. A1.1 shows the assumed energy loss versus the angle of the pendulum position during the pendulum swing. The correction chart to be described is principally the left half of Fig. A1.1. The windage and friction correction charts should be available from commercial testing machine manufacturers. The energy losses designated as A or B are described in 10.3.

TABLE 1 Precision for Charpy Test

Material	Values in ft-lbf/in. of Width					Number of Laboratories
	Average	S_r^A	S_R^B	r^C	R^D	
Phenolic Reinforced	0.55	0.029	0.050	0.08	0.14	7
nylon	1.98	0.065	0.143	0.18	0.40	7
Polycarbonate	2.85	0.083	0.422	0.23	1.19	8
Polypropylene	4.06	0.151	0.422	0.42	1.19	9
ABS	10.3	0.115	0.629	0.32	1.78	9

^A S_r = within-laboratory standard deviation for the indicated material. It is obtained by pooling the within-laboratory standard deviations of the test result from all of the participating laboratories:

$$S_r = [[(S_1)^2 + (S_2)^2 \dots + (S_n)^2] / n]^{1/2}$$

^B S_R = between-laboratories reproducibility, expressed as standard deviation:

$$S_R = [S_r^2 + S_L^2]^{1/2}$$

where S_L = standard deviation of laboratory means.

^C r = within-laboratory critical interval between two test results = $2.8 \times S_r$.

^D R = between laboratories critical interval between two test results = $2.8 \times S_R$.

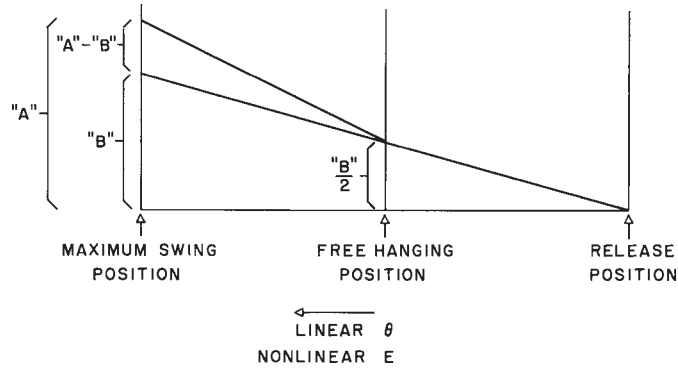

FIG. A1.1 Method of Construction of a Windage and Friction Correction Chart

A1.2 Start the construction of the correction chart (Fig. A1.2) by laying off to some convenient linear scale on the abscissa of a graph the angle of pendulum position for the portion of the swing beyond the free hanging position. For convenience, place the free hanging reference point on the right end of the abscissa with the angular displacement increasing linearly to the left. The abscissa is referred to as Scale C. Although angular displacement is the quantity to be represented linearly on the abscissa, this displacement is more conveniently expressed in terms of indicated energy read from the machine dial. This yields a nonlinear Scale C with indicated pendulum energy increasing to the right.

A1.3 On the right hand ordinate lay off a linear Scale B starting with zero at the bottom and stopping at the maximum expected pendulum friction and windage value at the top.

A1.4 On the left ordinate construct a linear Scale D ranging from zero at the bottom to 1.2 times the maximum ordinate value appearing on Scale B, but make the scale twice the scale used in the construction of Scale B.

A1.5 Adjoining Scale D draw a curve OA which is the focus of points whose coordinates have equal values of energy correction on Scale D and indicated energy on Scale C. This curve is referred to as Scale A and utilizes the same divisions and numbering system as the adjoining Scale D.

A1.6 Instructions for Using Chart:

A1.6.1 Locate and mark on Scale A the reading A obtained from the free swing of the pendulum with the pointer prepositioned in the free hanging or maximum indicated energy position on the dial.

A1.6.2 Locate and mark on Scale B the reading B obtained after several free swings with the pointer pushed up close to zero indicated energy position of the dial by the pendulum in accordance with instructions in 10.3.

A1.6.3 Connect the two points thus obtained by a straight line.

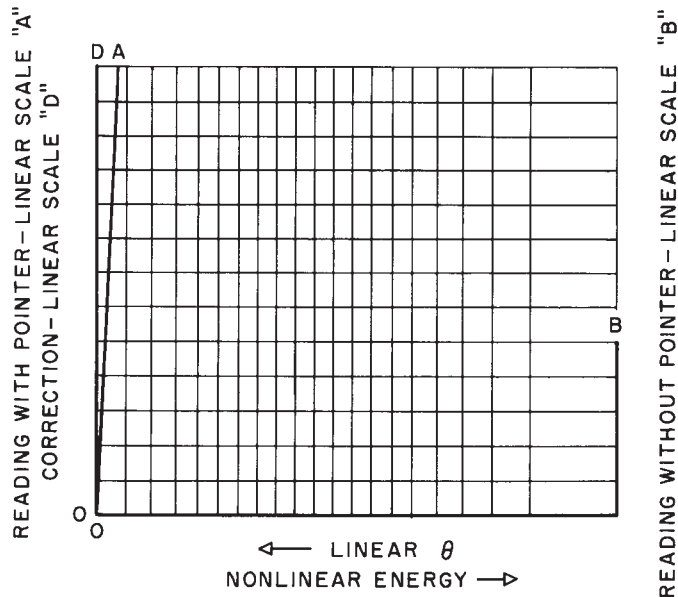

FIG. A1.2 Sample Windage and Friction Correction Chart

A1.6.4 From the indicated impact energy on Scale C project up to the constructed line and across to the left to obtain the correction for windage and friction from Scale D.

A1.6.5 Subtract this correction from the indicated impact reading to obtain the energy delivered to the specimen.

A2. PROCEDURE FOR THE CALCULATION OF WINDAGE AND FRICTION CORRECTION

A2.1 The procedure for the calculation of the windage and friction correction in this annex is based on the equations developed by derivation in Appendix X3. This procedure ~~can be used~~ is acceptable as a substitute for the graphical procedure described in Annex A1 and is applicable to small electronic calculator and computer analysis.

A2.2 Calculate L , the distance from the axis of support to the center of percussion as indicated in 6.3. It is assumed here that the center of percussion is approximately the same as the center of strike.

A2.3 Measure the maximum height, h_M , of the center of percussion (center of strike) of the pendulum at the start of the test as indicated in X2.16.

A2.4 Measure and record the energy correction, E_A , for windage of the pendulum plus friction in the dial, as determined with the first swing of the pendulum with no specimen in the testing device. This correction must be read on the energy scale, E_M , appropriate for the pendulum used.

A2.5 Without resetting the position of the indicator obtained in A2.4, measure the energy correction, E_B , for pendulum windage after two additional releases of the pendulum with no specimen in the testing device.

A2.6 Calculate β_{\max} as follows:

$$\beta_{\max} = \cos^{-1} \{1 - [(h_M/L)(1 - E_A/E_M)]\} \quad (\text{A2.1})$$

where:

- E_A = energy correction for windage of pendulum plus friction in dial, J-([ft·lbf]),
- E_M = full-scale reading for pendulum used, J-([ft·lbf]),
- L = distance from fulcrum to center of strike of pendulum, m-(ft), [ft],
- h_M = maximum height of center of strike of pendulum at start of test, m-(ft), [ft], and
- β_{\max} = maximum angle pendulum will travel with one swing of the pendulum.

A2.7 Measure specimen breaking energy, E_S , J-([ft·lbf]).

A2.8 Calculate β for specimen measurement E_S as:

$$\beta = \cos^{-1} \{1 - [(h_M/L)(1 - E_S/E_M)]\} \quad (\text{A2.2})$$

where:

- β = angle pendulum travels for a given specimen, and
- E_S = dial reading breaking energy for a specimen, J-([ft·lbf]).

A2.9 Calculate total correction energy, E_{TC} as:

$$E_{TC} = (E_A - (E_B/2))(\beta/\beta_{\max}) + (E_B/2) \quad (\text{A2.3})$$

where:

- E_{TC} = total correction energy for the breaking energy, E_S , of a specimen, J-([ft·lbf]), and
- E_B = energy correction for windage of the pendulum, J-([ft·lbf]).

A2.10 Calculate the impact resistance using the following formula:

$$I_s = (E_S - E_{TC})/t \quad (\text{A2.4})$$

where:

- I_s = impact resistance of specimen, J/m-([ft·lbf/in.]) of width, and
- t = width of specimen or width of notch, m-(in.) [in.]

APPENDIXES

(Nonmandatory Information)

X1. PROCEDURE FOR THE INSPECTION AND VERIFICATION OF NOTCH

X1.1 The purpose of this procedure is to describe the microscopic method to be used for determining the radius and angle of the notch. These measurements could also be made using a comparator if available.

NOTE X1.1—The notch shall have a radius of 0.25 ± 0.05 mm—([0.010 ± 0.002 in.]) and an angle of $45 \pm 1^\circ$.

X1.2 *Apparatus* :

X1.2.1 *Optical Device*, with minimum magnification of 60×, Filar glass scale and camera attachment.

X1.2.2 *Transparent Template*, that will be developed in this procedure.

X1.2.3 *Ruler*.

X1.2.4 *Compass*.

X1.2.5 *Plastic Drafting Set Squares (Triangles)*, 45–45–90°.

X1.3 A transparent template must be developed for each magnification and for each microscope used. It is preferable that each laboratory standardize on one microscope and one magnification. It is not necessary for each laboratory to use the same magnification because each microscope and camera combination have somewhat different blowup ratios.

X1.3.1 Set the magnification of the optical device at a suitable magnification with a minimum magnification of 60×.

X1.3.2 Place the Filar glass slide on the microscope platform. Focus the microscope so the most distinct of the Filar scale is visible.

X1.3.3 Take a photograph of the Filar scale (see Fig. X1.1).

X1.3.4 Create a template similar to that shown in Fig. X1.2.

X1.3.4.1 Find the approximate center of the piece of paper.

X1.3.4.2 Draw a set of perpendicular coordinates through the center point.

X1.3.4.3 Draw a family of concentric circles that are spaced according to in accordance with the dimensions of the Filar scale. This task is accomplished by first setting a mechanical compass at a distance of 0.1 mm—([0.004 in.]) as referenced by the magnified photograph of the Filar eyepiece. Subsequent circles shall be spaced 0.02 mm apart—([0.001 in.]), as rings, with the outer ring being 0.4 mm—([0.016 in.]) from the center.

X1.3.5 Photocopy the paper with the concentric circles to make a transparent template of the concentric circles.

X1.3.6 Construct Fig. X1.3 by taking a second piece of paper, finding its approximate center, and marking this point. Draw one line through this center point. Label this line zero degree (0°). Draw a second line perpendicular to the first line through this center point. Label this line 90°. From the center draw a line that is 44° relative to the 0°. Label the line 44°. Draw another line at 46°. Label the line 46°.

X1.4 Place a microscope glass slide on the microscope platform. Place the notched specimen on top of the slide. Focus the microscope. Move the specimen around using the platform adjusting knobs until the specimen's notch is centered and near the

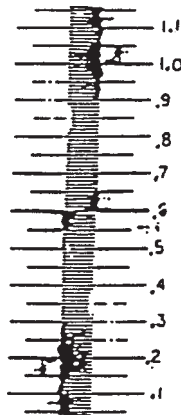

NOTE 1—100× reference.

NOTE 2—0.1 mm major scale; 0.01 mm minor scale.

FIG. X1.1 Filar Scale

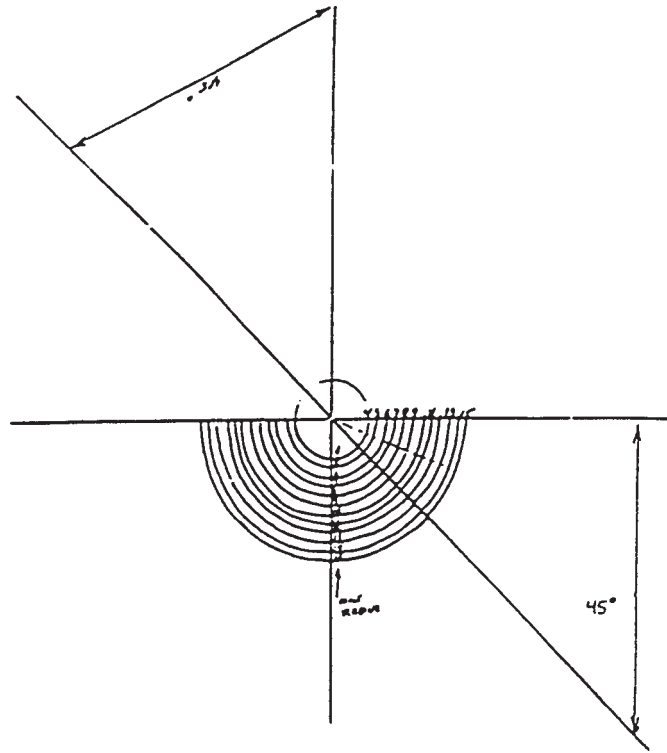

NOTE 1—Magnification = 100×.

FIG. X1.2 Example of Transparent Template for Determining Radius of Notch

bottom of the viewing area. Take a picture of the notch.

X1.4.1 *Determination of Notching Radius* (Fig. X1.4):

X1.4.1.1 Place the picture on a sheet of paper. Position the picture so that bottom of the notch in the picture faces downwards and is about 64 mm—[2.5 in.] from the bottom of the paper. Tape the picture down to the paper.

X1.4.1.2 Draw two lines along the sides of the notch projecting down to a point where they intersect below the notch Point I (see Fig. X1.4B).

X1.4.1.3 Open the compass to about 51 mm—(2 in.)—[2 in.]. Using Point I as a reference, draw two arcs intersecting both sides of the notch (see Fig. X1.4C). These intersections are called 1a and 1b.

X1.4.1.4 Close the compass to about 38 mm—[1.5 in.]. Using Point 1a as the reference point, draw an arc (2a) above the notch, draw a second arc (2b) that intersects with arc 2a at Point J. Draw a line between I and J. This establishes the centerline of the notch (see Fig. X1.4D)

X1.4.1.5 Place the transparent template on top of the picture and align the center of the concentric circles with the drawn centerline of the notch (see Fig. X1.4E).

X1.4.1.6 Slide the template down the centerline of the notch until one concentric circle touches both sides of the notch. Record the radius of the notch and compare it against the limits of 0.2 to 0.3 mm—[0.008 to 0.012 in.].

X1.4.1.7 Examine the notch to ensure that there are no flat spots along the measured radius.

X1.4.2 *Determination of Notch Angle* —Place transparent template for determining notch angle (Fig. X1.3) on top of the photograph attached to the sheet of paper. Rotate the picture so that the notch tip is pointed towards you. Position the center point of the template on top of the Point I established in 0° axis of the template with the right side straight portion of the notch. Check the left side straight portion of the notch to ensure that this portion falls between the 44° and 46° lines. If not, replace the blade.

X1.5 A picture of a notch shall be taken at least every 500 notches or if a control sample gives a value outside its 3-sigma limits for that test.

X1.6 If the notch in the control specimen is not within the requirements, a picture of the notching blade should be taken and analyzed by the same procedure used for the specimen notch. If the notching blade does not meet ASTM requirements or shows damage, it should be replaced with a new blade which has been checked for proper dimensions.

X1.7 It is possible that the notching If a cutter may have has the correct dimensions, but does not cut the correct notch in the specimen. If that occurs, specimen, it will be necessary to evaluate other conditions (cutter and feed speeds) to obtain the correct

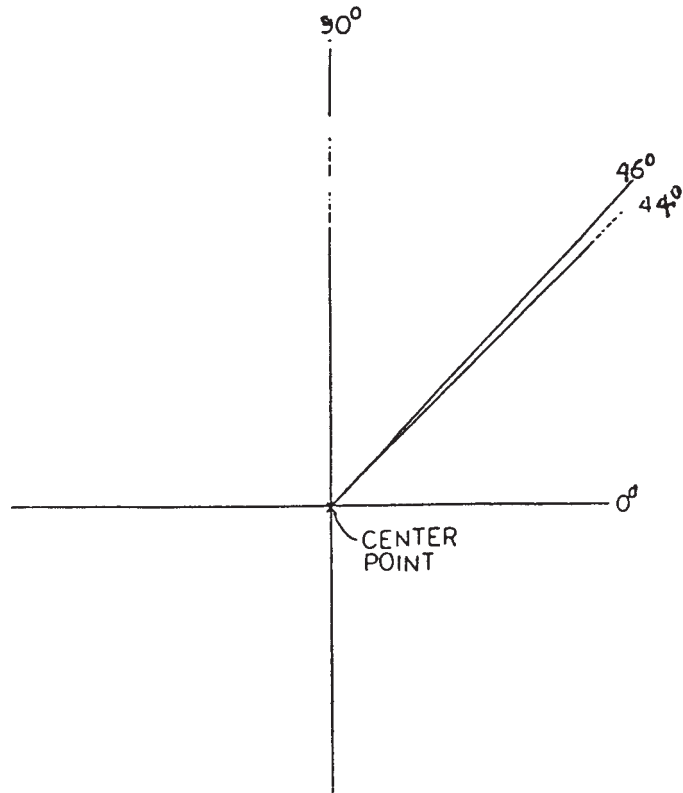

FIG. X1.3 Example of Transparent Template for Determining Angle of Notch

notch dimension for that material.

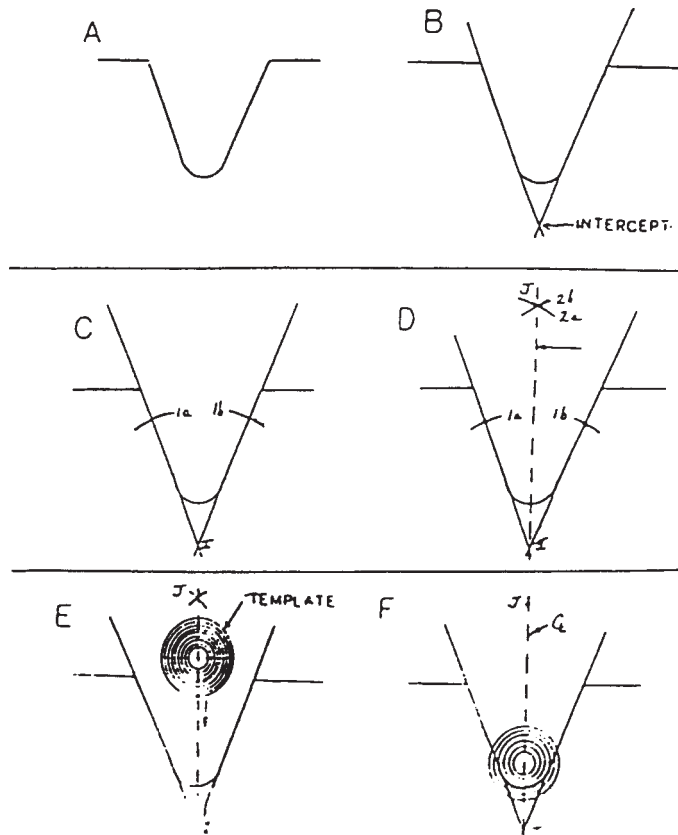

FIG. X1.4 Determining Radius

X2. CALIBRATION OF PENDULUM-TYPE HAMMER IMPACT MACHINES FOR USE WITH PLASTIC SPECIMENS

X2.1 This calibration procedure applies specifically to the Charpy impact machine.

X2.2 Locate the impact machine on a sturdy base. It shall not walk on the base and the base shall not vibrate appreciably. Loss of energy from vibrations will give high readings. It is recommended that the impact tester be bolted to a base having a mass of at least 23 kg if it is used at capacities higher than 2.7 J (2 ft·lbf).

X2.3 Check the level of the machine in both directions on the plane of the base with spirit levels mounted in the base, by a machinist's level if a satisfactory reference surface is available, or with a plumb bob. The machine should be made level to within $\tan^{-1} 0.001$ in the plane of swing and to within $\tan^{-1} 0.002$ in the plane perpendicular to the swing.

X2.4 Contact the machine manufacturer for a procedure to ensure the striker radius is in tolerance (3.17 ± 0.12 mm) (see 6.3).

X2.5 Check the transverse location of the center of the pendulum striking edge that shall be within 0.40 mm (0.016 in.) of the center of the anvil. Readjust the shaft bearings or relocate the anvil or straighten the pendulum shaft as necessary to attain the proper relationship between the two centers.

X2.6 Check the pendulum arm for straightness within 1.2 mm (0.05 in.) with a straightedge or by sighting down the shaft. This arm is sometimes bent by allowing the pendulum to slam against the catch when high-capacity weights are on the pendulum.

X2.7 Center a notched 12.7-mm square metal bar having opposite sides parallel within 0.025 mm and 125 mm long on the Charpy anvils. Place a thin oil film on the striking edge of the pendulum with an oiled cloth and let the striking edge rest gently against the bar. A thin line of oil should be transferred across the entire width of the bar, thereby verifying that the striking edge is in contact across the entire specimen width.

X2.8 When the pendulum is hanging free in its lowest position, the energy reading must be within 0.2 % of full scale.

X2.9 Swing the pendulum to a horizontal position, and support it by the striking edge in this position with a vertical bar. Allow the other end of this bar to rest at the center of a load pan on a balanced scale. Subtract the weight of the bar from the total weight

to find the effective weight of the pendulum. The effective pendulum weight should be within 0.4 % of the required weight for that pendulum capacity. If weight must be added or removed, take care to balance the added or removed weight without affecting the center of percussion relative to the striking edge. It is not advisable to add weight to the opposite side of the bearing axis from the striking edge to decrease the effective weight of the pendulum since the distributed mass ~~can lead~~ has the potential to result in large energy losses from vibration of the pendulum.

X2.10 Calculate the effective length of the pendulum arm or the distance to the center of percussion from the axis of rotation by the procedure in Note 5. The effective length must be within the tolerance stated in 6.3.

X2.11 Determine the vertical distance of fall of the pendulum striking edge from its latched height to its lowest point. This distance should be 610 ± 2 mm. This measurement ~~can be~~ is made with a half-width specimen positioned on the anvils. Place a thin oil film on the specimen and bring the striking edge against it. The upper end of the oil line on the striking edge is the center of strike. Measure the change in vertical height of the center of strike from the latched to the free hang position (the lowest point). This vertical fall distance ~~may be~~ is adjusted by varying the position of the pendulum latch.

X2.12 If a pointer and dial mechanism is used to indicate the energy, the pointer friction should be adjusted so that the pointer will just maintain its position anywhere on the scale. The striking pin of the pointer should be securely fastened to the pointer. Friction washers with glazed surfaces should be replaced with new washers. Friction washers should be on either side of the pointer collar. The last friction washer installed should be backed by a heavy metal washer. Pressure on this metal washer is produced by a thin bent spring washer and locknuts. If the spring washer is placed next to the fiber friction washer, the pointer will tend to vibrate during impact.

X2.13 The free-swing reading of the pendulum (without specimen) from the latched height should be less than 2.5 % of pendulum capacity on the first swing. If the reading is higher than this, the friction in the indicating mechanism is excessive or the bearings are dirty. To clean the bearings, dip them in grease solvent and spin dry in an air jet. Clean the bearings until they spin freely or replace them. Oil very lightly with instrument oil before replacing. A reproducible method of starting the pendulum from the proper height must be devised.

X2.14 The shaft about which the pendulum rotates shall have no detectable radial play, less than 0.05 mm ($[0.002$ in.]). An end play of 0.25 mm ($[0.010$ in.]) is permissible when a 9.8-N ($[2.2$ lbf]) axial force is applied in alternate directions.

X2.15 The machine should not be used to indicate more than 85 % of the energy capacity of the pendulum. Extra weight added to the pendulum will increase available energy of the machine. This weight must be added so as to maintain the center of percussion within the tolerance stated in 6.3. Correct effective weight for any range ~~can be~~ is calculated as follows:

$$W = E_p / h \quad (X2.1)$$

where:

W = the effective pendulum weight, N (~~lbf~~) [lbf] (see X2.13),

E_p = potential or available energy of the machine, J (~~ft × lbf~~); [ft × lbf], and

h = the vertical distance of fall of the pendulum striking edge, m (~~ft~~) [ft] (see X2.11).

Each 4.5 N (~~1 lbf~~) [1 lbf] of added effective weight increases the capacity of the machine by 2.7 J (~~2 [2 ft × lbf] × lbf~~).

NOTE X2.1—If the pendulum is designed for use with add-on weight, it is recommended that they be obtained through the equipment manufacturer.

X3. DERIVATION OF PENDULUM IMPACT CORRECTION EQUATIONS

X3.1 From right triangle distances in Fig. X3.1:

$$L - h = L \cos \beta \quad (X3.1)$$

X3.2 The potential energy gain of pendulum, E_p , is:

$$E_p = hW_p g \quad (X3.2)$$

X3.3 Combining Eq X3.1 and Eq X3.2 gives the following:

$$L - E_p / W_p g = L \cos \beta \quad (X3.3)$$

X3.4 The maximum energy of the pendulum is the potential energy at the start of the test, E_M , or

$$E_M = h_M W_p g \quad (X3.4)$$

X3.5 The potential energy gained by the pendulum, E_p , is related to the absorption of energy of a specimen, E_s , by the following equation:

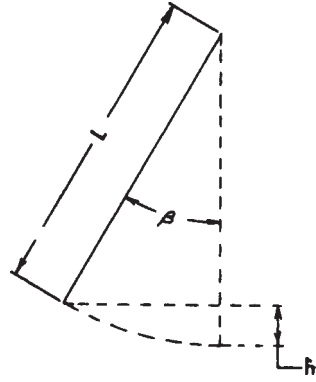

FIG. X3.1 Swing of Pendulum from Its Rest Position

$$E_M - E_s = E_p \tag{X3.5}$$

X3.6 Combining Eq X3.3-X3.5 gives the following:

$$(E_M - E_s)/E_M = L/h_M(1 - \cos \beta) \tag{X3.6}$$

X3.7 Solving Eq X3.6 for β gives the following:

$$\beta = \cos^{-1} \{1 - [(h_M/L)(1 - E_s/E_M)]\} \tag{X3.7}$$

X3.8 From Fig. X3.2, the total energy correction, E_{TC} , is given as:

$$E_{TC} = m\beta + b \tag{X3.8}$$

X3.9 At the zero point of the pendulum the potential energy is:

$$E_B/2 = m(0) + b \tag{X3.9}$$

or

$$b = E_B/2 \tag{X3.9}$$

X3.10 The energy correction, E_A , on the first swing of the pendulum occurs at the maximum pendulum angle, β_{\max} . Substituting in Eq X3.8 gives the following:

$$E_A = m\beta_{\max} + (E_B/2) \tag{X3.10}$$

X3.11 Combining Eq X3.8 and Eq X3.11 gives the following:

$$E_{TC} = (E_A - (E_B/2))(\beta/\beta_{\max}) + (E_B/2) \tag{X3.11}$$

X3.12 *Nomenclature* :

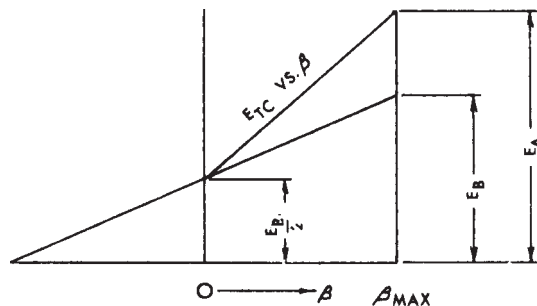

FIG. X3.2 Total Energy Correction for Pendulum Windage and Dial Friction as a Function of Pendulum Position

- b = intercept of total correction energy straight line,
 E_A = energy correction, including both pendulum windage plus dial friction, J,
 E_B = energy correction for pendulum windage only, J,
 E_M = maximum energy of the pendulum (at the start of test), J,
 E_p = potential energy gain of pendulum from the pendulum rest position, J,
 E_S = uncorrected breaking energy of specimen, J,
 E_{TC} = total energy correction for a given breaking energy, E_S , J,
 g = acceleration of gravity, m/s²,
 h = distance center of gravity of pendulum rises vertically from the rest position of the pendulum, m,
 h_m = maximum height of the center of gravity of the pendulum, m,
 m = slope of total correction energy straight line,
 L = distance from fulcrum to center of gravity of pendulum, m,
 W_p = weight of pendulum, as determined in X2.13, kg, and
 β = angle of pendulum position from the pendulum rest position.

X4. UNIT CONVERSIONS

X4.1 Joules per metre cannot be converted directly into kilojoules per square metre.

NOTE X4.1—The optional units of kJ/m² [(ft·lbf/in.²)] also may be required; therefore, the cross-sectional area under the notch must be reported.

X4.2 The following examples are approximations:

1ft·lbf/39.37 in.	= 1.356 J/m
1ft·lbf/in.	= (39.37)(1.356) J/m
1ft·lbf/in.	= 53.4 J/m
1ft·lbf/in.	= 0.0534 kJ/m
1ft·lbf/1550 in. ²	= 1.356 J/m ²
1ft·lbf/in. ²	= (1550)(1.356) J/m ²
1ft·lbf/in. ²	= 2101 J/m ²
1ft·lbf/in. ²	= 2.1 kJ/m ²

SUMMARY OF CHANGES

This section identifies the location of selected changes to this test method. For the convenience of the user, Committee D20 has highlighted those changes that impact the use of this test method. This section also includes descriptions of the changes or reasons for the changes, or both.

D6110-04:

- (1) Add reference to D5947 in paragraph 2.1.
- (2) Changed requirements for micrometer in paragraph 6.3.
- (3) Removed requirement to mill draft angle from specimens.
- (4) Changed notch depth dimensions to 10.16 ± 0.05 mm in order to agree with Figure 4; and clarified procedure to measure notch depth in paragraph 8.2.
- (5) Added paragraphs 10.3.2 and 10.3.3 on clarifying notch depth measuring technique. Renumbered subsequent sections.
- (6) Added Figure 6.
- (7) Permissive language removed.
- (8) Imperial units added for reference.

ASTM International takes no position respecting the validity of any patent rights asserted in connection with any item mentioned in this standard. Users of this standard are expressly advised that determination of the validity of any such patent rights, and the risk of infringement of such rights, are entirely their own responsibility.

This standard is subject to revision at any time by the responsible technical committee and must be reviewed every five years and if not revised, either reapproved or withdrawn. Your comments are invited either for revision of this standard or for additional standards and should be addressed to ASTM International Headquarters. Your comments will receive careful consideration at a meeting of the responsible technical committee, which you may attend. If you feel that your comments have not received a fair hearing you should make your views known to the ASTM Committee on Standards, at the address shown below.

This standard is copyrighted by ASTM International, 100 Barr Harbor Drive, PO Box C700, West Conshohocken, PA 19428-2959, United States. Individual reprints (single or multiple copies) of this standard may be obtained by contacting ASTM at the above address or at 610-832-9585 (phone), 610-832-9555 (fax), or service@astm.org (e-mail); or through the ASTM website (www.astm.org).