



Designation: D 6265 – 98

Standard Practice for Separation of Contaminants in Polymers Using an Extruder Filter Test¹

This standard is issued under the fixed designation D 6265; the number immediately following the designation indicates the year of original adoption or, in the case of revision, the year of last revision. A number in parentheses indicates the year of last reapproval. A superscript epsilon (ϵ) indicates an editorial change since the last revision or reapproval.

1. Scope

1.1 This practice covers a means to separate the unmolten particles, gels, and impurities contaminating a polymer sample. The procedure may be used to remove gels and incompatible materials that may cause imperfections in the final extruded product. Under pressure, most gels will break up or deform and pass through a wire mesh filter, however high molecular weight gels may not break up or deform.

1.2 If desired, materials isolated on a wire mesh filter can subsequently be identified by spectroscopic or other analytical means.

NOTE 1—Although not presented as a quantitative method, the procedure presented in this practice may be used to provide quantitative results at the discretion of the user. The user assumes the responsibility to verify the reproducibility of quantitative results. Detection limit depends on the mesh size of the filter screen, but the procedure is generally applicable to the separation of immiscible contaminants present at concentrations greater than 0.1 %.

1.3 The values stated in SI units are to be regarded as the standard.

1.4 *This standard does not purport to address the safety concerns, if any, associated with its use. It is the responsibility of the user of this standard to establish appropriate safety and health practices and determine the applicability of regulatory limitations prior to use.* For specific hazards statements, see Section 8.

NOTE 2—There is no equivalent ISO standard.

2. Referenced Documents

2.1 ASTM Standards:

D 1238 Test Method for Flow Rates of Thermoplastics by Extrusion Plastometer²

D 1600 Terminology for Abbreviated Terms Relating to Plastics²

D 5033 Guide for the Development of Standards Relating to the Proper Use of Recycled Plastics³

E 380 Practice for Use of the International System of Units

¹ This test method is under the jurisdiction of ASTM Committee D20 on Plastics and is the direct responsibility of Subcommittee D20.95 on Recycled Plastics.

Current edition approved May 10, 1998. Published February 1999.

² *Annual Book of ASTM Standards*, Vol 08.01.

³ *Annual Book of ASTM Standards*, Vol 08.03.

(SI) (the Modernized Metric System)⁴

3. Terminology

3.1 The terminology used in this practice is in accordance with Terminology D 1600 and Guide D 5033. Units and symbols are in accordance with Practice E 380.

4. Summary of Practice

4.1 As polymer passes through a wire mesh filter of known area and porosity (for example, 0.00032 m² (0.049 in.²) of a 325 mesh screen) positioned in line at the end of an extruder barrel, the filter becomes blocked by impurities and gels. This procedure is used to remove gels and contaminants that may result in undesirable imperfections in the extruded product. This blockage results in a proportional rise in the pressure behind the filter. Although this Practice is not designed to provide any quantitative estimate of the level of contamination, the rate of this pressure rise may be correlated to the level of contamination through appropriate experiments.

5. Significance and Use

5.1 Presence of paper, metal, gels, incompatible polymer, or other extraneous contamination in polymers, including recycled polymers, may cause problems with extrusion and subsequent processing of the material. This procedure is useful for separating gross contaminants from polymers. For example, the procedure is useful for determining the quality of resins to be used in fiber applications. If desired, the isolated contaminants may be subsequently identified by the appropriate visual or instrumental procedures.

6. Apparatus

6.1 *Extruder*, designed to deliver a continuous supply of molten resin to a filter at a uniform rate with good temperature control. An extruder with 25 to 64-mm barrel has been found to be useful.

6.1.1 *Internal Rod Die*, to fix the filter area. Fig. 1 shows a typical 6.4 mm diameter die that gives a filter area of 12.45 mm².

6.1.2 *Breaker Plate or Screen Holder*—A typical configuration is shown in Fig. 2.

⁴ *Annual Book of ASTM Standards*, Vol 14.02.

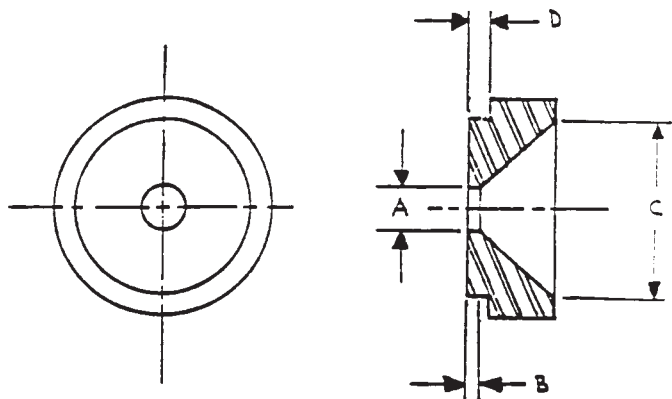

NOTE—A = 0.250 in.,

B = 0.0625 in.,

C = same diameter as extruder barrel, and

D = dimension that when added to the total thickness of the screen pack shall exceed the depth of the screen-retaining recess of the breaker plate to permit compression of the screens.

FIG. 1 Schematic Showing the Internal Sizing of the (Rod) Die

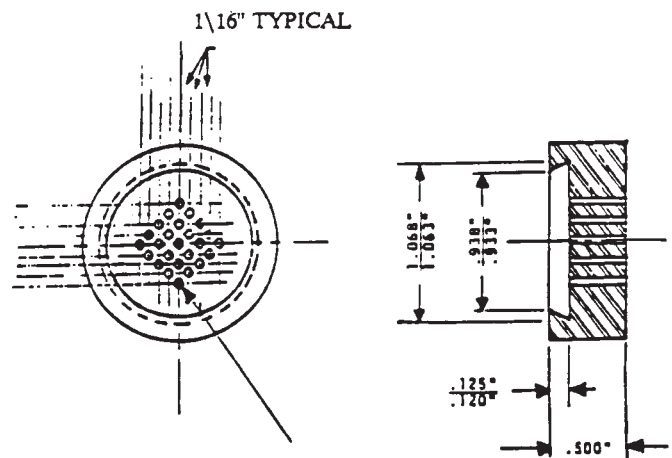

NOTE—Drill 25 holes; use #60 drill.

FIG. 2 Schematic of the Breaker Plate

6.1.3 *Pressure Transducer*, installed in-line before the screen pack and connected to digital readout and a chart recorder.

6.1.4 *Melt Thermocouple*, installed before or after the screen pack and connected to a chart recorder.

6.1.5 *High Pressure Alarm and Rupture Disk*.

6.1.6 *Split Clamp*, to permit ready access to the screens, sizing die, and breaker plate.

6.1.7 *Swing Gate*, to support the split clamp (6.1.6) during screen changes.

NOTE 3—Although desirable, a swing gate is not always available on small extruders.

6.2 *Screens*, 25.4 mm diameter (60 mesh (0.251 mm opening), 100 mesh (0.152 mm opening), 200 mesh (0.076 mm opening), 325 mesh, or other appropriate sizes).

6.3 *Strip Chart Recorder*, with a speed of 15 cm/h.

6.4 *Balance*, capable of weighing with accuracy of ± 0.1 kg.

6.5 *Torque Wrench*, with ratchet drive attachment.

6.6 *Thermally Insulated Gloves*.

6.7 *Spatulas and Scrapers*, brass, assorted sizes for removing molten polymer from equipment.

7. Materials

7.1 *Virgin Polymer*, free of gels and contaminants, for purging the extruder equipment.

8. Hazards

8.1 Hot polymer can cause serious burns. Do not stand in front of the extruder because air bubbles, excessive temperature or pressure can cause hot polymer to be expelled from the extruder die.

8.2 Always wear thermally insulated gloves when handling hot polymer or working directly with the heated areas of the extruder.

9. Procedure

9.1 Turn on the power to the extruder and turn on the feed throat cooling water.

9.2 Set extruder temperature controllers to maintain the barrel at the appropriate temperature for the polymer (see Table 1).

9.3 Wait at least 30 min after achieving melt temperature before starting the extruder.

9.4 Insert a new screen pack using 60 (0.251 mm opening)-100 (0.152 mm opening) -60 mesh screens plus the backing screens for the extruder purge.

NOTE 4—The screen pack must have sufficient depth to prevent the breaker plate from fully contacting the rod die. This helps keep the screens firmly in place, insures the correct surface area of filter screw is actually used during the test, and simplifies disassembly.

9.5 Close the split clamp and tighten to 6.9 kg-m (50 ft-lb) using a torque wrench (this and other requirements may vary depending on the extruder model).

NOTE 5—Allow the breaker plate and rod die to heat up for an additional 5 min to melt any residual solidified polymer before starting the extruder.

9.6 Charge the hopper with 14 kg virgin polymer and start the extruder.

9.7 Adjust the screw speed to the desired setting and purge the system with virgin polymer.

9.7.1 For startup after more than 4 hours of non-use, purge 20 min at 10 to 20 rpm followed by 5 to 8 min at 100 rpm.

TABLE 1 Suggested Extruder Temperatures

Polymer	Extruder Temperature, °C
Acetals	190
Acrylics	230
Nylon	275
Polycarbonate	300
Polyethylene	200
Poly(ethylene terephthalate)	280
Polypropylene	230
Polystyrene	200
Poly(vinyl acetal)	150
Styrene-acrylonitrile	225

9.7.2 For systems with less than 4 h of non-use, purge 10 to 15 min at 10 to 20 rpm followed by 3 to 4 min at 80 rpm.

9.8 Empty and refill the hopper with the test sample and purge for 5 min at 40 to 60 rpm.

9.9 Shut down the extruder and immediately change the screen pack assembly to the following sequence:

9.9.1 Extruder, rod die, 325 mesh screen, 200 mesh screen (0.076 mm opening), 100 mesh screen (0.152 mm opening), 60 mesh screen (0.251 mm opening), backing screens (60 mesh or higher), and the breaker plate.

NOTE 6—Referring to Fig. 3, the screen pack must have sufficient depth to prevent the breaker plate from fully contacting the rod die. Screens of other mesh size may be substituted.

9.10 Start the extruder and bring it up to a screw speed of 100 rpm as quickly as possible while observing pressure and load readouts for any excessive increases. Start the chart recorder.

9.11 Once the pressure has stabilized for at least 5 min and the system is at the correct temperature, cut off the extrudate at the strip die and begin collection. Record the filter pressure (P_i) to the nearest 0.2 Mpa. If the pressure continues to rise, but not stabilize, stop the extruder before attaining the maximum safe operating pressure for the equipment. Note and report the rate of pressure rise.

9.12 Continue extruding the polymer monitoring the filter pressure for 20 to 30 min or until 14 kg of polymer has been extruded. Record the filter pressure at the end of the collection cycle (P_f) to the nearest 0.2 MPa.

NOTE 7—After the filters are installed, carefully watch the filter back

pressure as the extrusion is restarted. If a rapid pressure rise occurs, stop the extrusion before exceeding the maximum safe operating pressure for the equipment.

NOTE 8—The extrudate can be collected as a total mass and weighed after all resin has been extruded or the extrusion rate may be determined and the filtration continued for the time required to filter 15 kg of resin.

9.13 Shut down the extruder.

NOTE 9—If running unstabilized polymer (for example, polyolefin flake), always purge the system with stabilized pellets before shutting down the extruder. Always return extruder drive to minimum rpm before shutting down the extruder. To prevent excessive degradation of polymer left in the extruder, turn down the temperatures or turn off all heaters depending on the duration of the shutdown.

9.14 Disassemble the screen pack and save the 325 mesh screen. Scrape any excess polymer off the screen while it is still hot to avoid disturbing any residues and to make the residue more visible.

10. Report

10.1 Report the following information:

- 10.1.1 The mesh size of screens used for the test,
- 10.1.2 The initial (P_i) and final (P_f) pressures or the rate of pressure rise if unable to obtain a stabilized pressure (see 9.11),
- 10.1.3 The extruder barrel temperature,
- 10.1.4 The elapsed time for operating the extruder, and
- 10.1.5 The presence of residue or contamination on the screens.

11. Keywords

11.1 contamination; extruder filtration test; polyolefins; recycled plastics

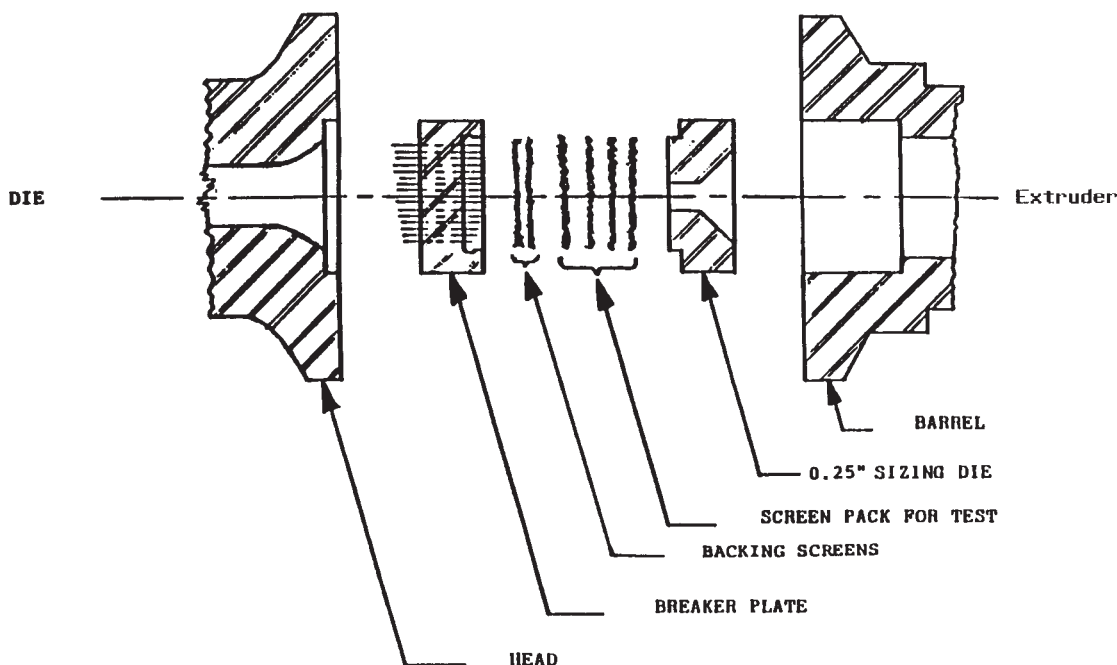

NOTE—Split clamp not to scale.

FIG. 3 Schematic of the Screen Pack Assembly

**NOTICE: This standard has either been superceded and replaced by a new version or discontinued.
Contact ASTM International (www.astm.org) for the latest information.**



ASTM International takes no position respecting the validity of any patent rights asserted in connection with any item mentioned in this standard. Users of this standard are expressly advised that determination of the validity of any such patent rights, and the risk of infringement of such rights, are entirely their own responsibility.

This standard is subject to revision at any time by the responsible technical committee and must be reviewed every five years and if not revised, either reapproved or withdrawn. Your comments are invited either for revision of this standard or for additional standards and should be addressed to ASTM International Headquarters. Your comments will receive careful consideration at a meeting of the responsible technical committee, which you may attend. If you feel that your comments have not received a fair hearing you should make your views known to the ASTM Committee on Standards, at the address shown below.

This standard is copyrighted by ASTM International, 100 Barr Harbor Drive, PO Box C700, West Conshohocken, PA 19428-2959, United States. Individual reprints (single or multiple copies) of this standard may be obtained by contacting ASTM at the above address or at 610-832-9585 (phone), 610-832-9555 (fax), or service@astm.org (e-mail); or through the ASTM website (www.astm.org).