



## Standard Specification for Poly(Vinyl Chloride) (PVC) Plastic Pipe Fittings, Schedule 80<sup>1</sup>

This standard is issued under the fixed designation D 2467; the number immediately following the designation indicates the year of original adoption or, in the case of revision, the year of last revision. A number in parentheses indicates the year of last reapproval. A superscript epsilon ( $\epsilon$ ) indicates an editorial change since the last revision or reapproval.

*This standard has been approved for use by agencies of the Department of Defense.*

### 1. Scope

1.1 This specification covers poly(vinyl chloride) (PVC) Schedule 80 pipe fittings. Included are requirements for materials, workmanship, dimensions, and burst pressure.

NOTE 1—CPVC plastic pipe fittings, which were formerly included in this standard, are now covered in Specification F 439.

1.2 The products covered by this specification are intended for use with the distribution of pressurized liquids only, which are chemically compatible with the piping materials. Due to inherent hazards associated with testing components and systems with compressed air or other compressed gases, some manufacturers do not allow pneumatic testing of their products. Consult with specific product/component manufacturers for their specific testing procedures prior to pneumatic testing.

NOTE 2—Pressurized (compressed) air or other compressed gases contain large amounts of stored energy, which present serious safety hazards should a system fail for any reason.

1.3 The text of this specification references notes, footnotes, and appendixes which provide explanatory material. These notes and footnotes (excluding those in tables and figures) shall not be considered as requirements of this specification.

1.4 The values stated in inch-pound units are to be regarded as the standard. The values given in parentheses are provided for information only.

1.5 The following safety hazards caveat pertains only to the test method portion, Section 8, of this specification. *This standard does not purport to address all of the safety concerns, if any, associated with its use. It is the responsibility of the user of this standard to establish appropriate safety and health practices and determine the applicability of regulatory limitations prior to use.*

<sup>1</sup> This specification is under the jurisdiction of ASTM Committee F17 on Plastic Piping Systems and is the direct responsibility of Subcommittee F17.10 on Fittings. Current edition approved ~~Sept. 10, 2002~~ April 1, 2004. Published ~~September 2002~~ May 2004. Originally published as D 2467 – 65 T, approved in 1965. Last previous edition approved in 2002 as D 2467 – 042.

## 2. Referenced Documents

### 2.1 *ASTM Standards:*<sup>2</sup>

- D 618 Practice for Conditioning Plastics for Testing
- D 1599 Test Method for Resistance to Short-Time Hydraulic Pressure of Plastic Pipe, Tubing, and Fittings
- D 1600 Terminology for Abbreviated Terms Relating to Plastics
- D 1784 Specification for Rigid Poly(Vinyl Chloride) (PVC) Compounds and Chlorinated Poly(Vinyl Chloride) (CPVC) Compounds
- D 1785 Specification for Poly(Vinyl Chloride) (PVC) Plastic Pipe, Schedules 40, 80, and 120
- D 2122 Test Method for Determining Dimensions of Thermoplastic Pipe and Fittings
- D 2749 Symbols for Dimensions of Plastic Pipe Fittings
- F 412 Terminology Relating to Plastic Piping Systems
- F 439 Specification for ~~Socket-Type~~ Chlorinated Poly (Vinyl Chloride) (CPVC) Plastic Pipe Fittings, Schedule ~~80~~<sup>3</sup> 80
- F 1498 Specification for Taper Pipe Threads 60° for Thermoplastic Pipe and Fittings

### 2.2 *Federal Standard:*<sup>3</sup>

Fed. Std. No. 123 Marking for Shipment (Civil Agencies)

### 2.3 *National Sanitation Foundation Standards:*<sup>4</sup>

- Standard No. 14 for Plastic Piping Components and Related Materials
- Standard No. 61 for Drinking Water Systems Components—Health Effects

## 3. Terminology

3.1 General—Definitions are in accordance with Terminology F 412 and abbreviations are in accordance with Terminology D 1600, unless otherwise indicated. The abbreviation for poly(vinyl chloride) plastic is PVC.

## 4. Classification

4.1 *General*—This specification covers Schedule 80 PVC pipe fittings, socket-type, made from four PVC plastic compounds and intended for use with Iron Pipe Size (IPS) outside-diameter plastic pipe.

4.1.1 Fittings covered by this specification are normally molded. In-line fittings, such as couplings, unions, bushings, caps, nipples, etc., and the like, shall be molded or machined from extruded stock.

4.1.2 Fittings fabricated by back welding or butt fusion are not included in this specification.

## 5. Materials and Manufacture

5.1 This specification covers PVC pipe fittings made from five PVC plastics as classified in Specification D 1784. These are PVC 12454-B, 12454-C, 13354-C, 11443-B, and 14333-D.

5.2 *Compound*—The PVC plastic compound shall meet the requirements of PVC 12454-B, 12454-C, 11443-B, or 14333-D, as described in Specification D 1784.

NOTE 3—Mechanical strength, heat resistance, flammability, and chemical resistance requirements are covered in Specification D 1784.

5.3 *Rework Material*—The manufacturers shall use only their own clean rework fitting material and the fittings produced shall meet all the requirements of this specification.

## 6. Requirements

### 6.1 *Dimensions and Tolerances:*

6.1.1 Fitting sockets inside diameters (waterways), minimum wall thicknesses, and dimensions shall be as shown in Tables 1-4 when measured in accordance with Test Method D 2122.

6.1.2 When multistep reducer bushings are cored out, the inner socket shall be reinforced from the outer wall by a minimum of three ribs extending from the top of the inner socket to the deepest extremity of the coring. The transition from D to DJ (Table 3) shall be straight, tapered as shown, or radiused. A positive taper in the same direction of the taper in the socket on the outside diameter of the bushing is optional.

6.1.3 The maximum angular variation of any opening shall be not more than ½ ° off the true centerline axis.

6.1.4 The minimum wall thickness of fittings shall be 125 % of the minimum wall thickness of the corresponding size of Schedule 80 pipe for which they are designed to be used, except that for the socket, the wall thickness shall be at least equal to the minimum wall thickness of the corresponding size of Schedule 80 pipe.

<sup>2</sup> For referenced ASTM standards, visit the ASTM website, [www.astm.org](http://www.astm.org), or contact ASTM Customer Service at [service@astm.org](mailto:service@astm.org). For *Annual Book of ASTM Standards*, Vol 08.04, volume information, refer to the standard's Document Summary page on the ASTM website.

*Annual Book of ASTM Standards*, Vol 08.04.

<sup>3</sup> Available from Standardization Documents Order Desk, Bldg. 4 Section D, 700 Robbins Ave., Philadelphia, PA 19111-5094, Attn: NPODS.

<sup>4</sup> Available from Standardization Documents Order Desk, Bldg. 4 Section D, 700 Robbins Ave., Philadelphia, PA 19111-5094, Attn: NPODS; the National Sanitation Foundation, P.O. Box 1468, Ann Arbor, MI 48106.

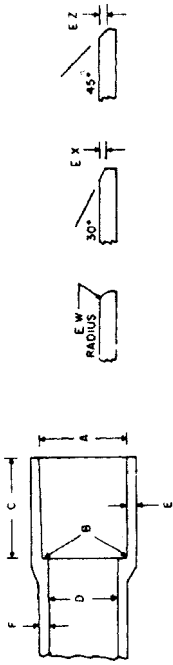
**TABLE 1 Tapered Sockets for PVC Pipe Fittings, Schedule 80, in. (mm)<sup>A</sup>**

Nominal Pipe Size	A Socket Entrance Diameter			B Socket Bottom Diameter			C <sup>B</sup> Socket Length, min	D <sup>C</sup> Inside Diameter, min	Wall Thickness, min			Entrance, min		
	Diameter	Tolerance on Nominal Diameter	Max Out-of-Round	Diameter	Tolerance on Nominal Diameter	Max Out-of-Round			E	F	EW	EX	EZ	
1/8	0.417 (10.59)	± 0.004 (0.10)	0.016 (0.41)	0.401 (10.18)	± 0.004 (0.10)	0.016 (0.41)	0.500 (12.7)	0.171 (4.34)	0.095 (2.41)	0.118 (3.00)	1/64 (0.40)	1/64 (0.40)	1/64 (0.40)	1/64 (0.40)
1/4	0.552 (14.02)	± 0.004 (0.10)	0.016 (0.41)	0.536 (13.61)	± 0.004 (0.10)	0.016 (0.41)	0.625 (15.88)	0.258 (6.55)	0.119 (3.02)	0.149 (3.78)	1/64 (0.40)	1/64 (0.40)	1/64 (0.40)	1/64 (0.40)
3/8	0.687 (17.45)	± 0.004 (0.10)	0.016 (0.41)	0.671 (17.04)	± 0.004 (0.10)	0.016 (0.41)	0.750 (19.05)	0.379 (9.63)	0.126 (3.20)	0.160 (4.06)	1/32 (0.79)	1/32 (0.79)	1/32 (0.79)	1/32 (0.79)
1/2	0.848 (21.54)	± 0.004 (0.10)	0.016 (0.41)	0.836 (21.23)	± 0.004 (0.10)	0.016 (0.41)	0.875 (22.22)	0.502 (12.75)	0.147 (3.73)	0.185 (4.70)	1/32 (0.79)	1/32 (0.79)	1/32 (0.79)	1/32 (0.79)
3/4	1.058 (26.87)	± 0.004 (0.10)	0.020 (0.51)	1.046 (26.57)	± 0.004 (0.10)	0.020 (0.51)	1.000 (25.40)	0.698 (17.73)	0.154 (3.91)	0.195 (4.95)	1/32 (0.79)	1/32 (0.79)	1/32 (0.79)	1/32 (0.79)
1	1.325 (33.65)	± 0.005 (0.13)	0.020 (0.51)	1.310 (33.27)	± 0.005 (0.13)	0.020 (0.51)	1.125 (28.58)	0.911 (23.14)	0.179 (4.55)	0.225 (5.72)	1/16 (1.59)	1/16 (1.59)	1/16 (1.59)	1/16 (1.59)
1 1/4	1.670 (42.42)	± 0.005 (0.13)	0.024 (0.61)	1.655 (42.04)	± 0.005 (0.13)	0.024 (0.61)	1.250 (31.75)	1.227 (31.17)	0.191 (4.85)	0.239 (6.07)	1/16 (1.59)	1/16 (1.59)	1/16 (1.59)	1/16 (1.59)
1 1/2	1.912 (48.56)	± 0.006 (0.15)	0.024 (0.61)	1.894 (48.11)	± 0.006 (0.15)	0.024 (0.61)	1.375 (34.93)	1.446 (36.73)	0.200 (5.08)	0.250 (6.35)	1/16 (1.59)	1/16 (1.59)	1/16 (1.59)	1/16 (1.59)
2	2.387 (60.63)	± 0.006 (0.15)	0.024 (0.61)	2.369 (60.17)	± 0.006 (0.15)	0.024 (0.61)	1.500 (38.10)	1.881 (47.78)	0.218 (5.54)	0.275 (6.99)	1/16 (1.59)	1/16 (1.59)	1/16 (1.59)	1/16 (1.59)
2 1/2	2.889 (73.38)	± 0.007 (0.18)	0.030 (0.76)	2.868 (72.85)	± 0.007 (0.18)	0.030 (0.76)	1.750 (44.45)	2.250 (57.15)	0.276 (7.01)	0.345 (8.76)	3/32 (2.38)	3/32 (2.38)	1/8 (3.18)	1/8 (3.18)
3	3.516 (89.31)	± 0.008 (0.20)	0.030 (0.76)	3.492 (88.70)	± 0.008 (0.20)	0.030 (0.76)	1.875 (47.63)	2.820 (71.63)	0.300 (7.62)	0.375 (9.53)	3/32 (2.38)	3/32 (2.38)	1/8 (3.18)	1/8 (3.18)
3 1/2	4.016 (102.01)	± 0.008 (0.20)	0.030 (0.76)	3.992 (101.4)	± 0.008 (0.20)	0.030 (0.76)	2.125 (53.98)	3.280 (83.31)	0.318 (8.08)	0.400 (10.16)	3/32 (2.38)	3/32 (2.38)	1/8 (3.18)	1/8 (3.18)
4	4.518 (114.76)	± 0.009 (0.23)	0.030 (0.76)	4.491 (114.1)	± 0.009 (0.23)	0.030 (0.76)	2.250 (57.15)	3.737 (94.92)	0.337 (8.56)	0.420 (10.67)	3/32 (2.38)	3/32 (2.38)	1/8 (3.18)	1/8 (3.18)
5	5.583 (141.81)	± 0.010 (0.25)	0.060 (1.52)	5.553 (141.0)	± 0.010 (0.25)	0.060 (1.52)	2.625 (66.68)	4.703 (119.46)	0.375 (9.53)	0.470 (11.94)	3/32 (2.38)	3/32 (2.38)	1/8 (3.18)	1/8 (3.18)
6	6.647 (168.83)	± 0.011 (0.28)	0.060 (1.52)	6.614 (168.0)	± 0.011 (0.28)	0.060 (1.52)	3.000 (76.20)	5.646 (143.41)	0.432 (10.97)	0.540 (13.72)	1/8 (3.18)	3/16 (4.76)	3/16 (4.76)	3/16 (4.76)
8	8.655 (219.84)	± 0.015 (0.38)	0.090 (2.29)	8.610 (218.7)	± 0.015 (0.38)	0.090 (2.29)	4.000 (101.60)	7.490 (190.25)	0.500 (12.70)	0.625 (15.88)	1/8 (3.18)	3/16 (4.76)	3/16 (4.76)	3/16 (4.76)
10	10.780 (273.81)	± 0.015 (0.38)	0.100 (2.54)	10.735 (272.67)	± 0.015 (0.38)	0.100 (2.54)	5.000 (127.00)	9.407 (238.94)	0.593 (15.06)	0.741 (18.82)	1/8 (3.18)	3/16 (4.76)	3/16 (4.76)	3/16 (4.76)
12	12.780 (324.61)	± 0.015 (0.38)	0.120 (3.05)	12.735 (323.47)	± 0.015 (0.38)	0.120 (3.05)	6.000 (152.40)	11.197 (284.40)	0.687 (17.45)	0.859 (21.82)	1/8 (3.18)	3/16 (4.76)	3/16 (4.76)	3/16 (4.76)

<sup>A</sup> The sketches and designs of fittings are illustrative only (taken from Symbols D 2749).

<sup>B</sup> Socket depth, measured from socket entrance face to socket bottom face.

<sup>C</sup> See 6.1.5.

**TABLE 2 Dimensions of 90° Ells, Tees, Crosses, 45° Elbows and Couplings (Straight Sizes), in. (mm)<sup>A</sup>**

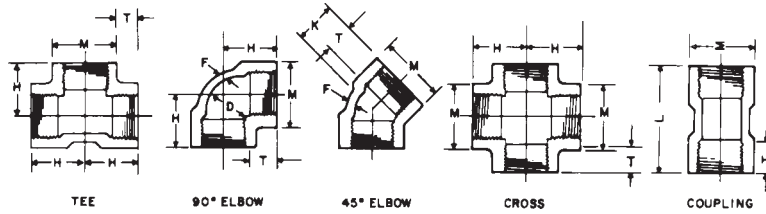

Nominal Pipe Size	Center to Thread End, 90° Elbows, Tees, Crosses, <sup>B</sup> H, min	Length of Thread, T, min	Center to Thread End, 45° Elbow, <sup>B</sup> K, min	Inside Diameter of Fitting, D, min	Nominal Wall Thickness, F, min	Outside Diameter of Band Hub, M, min	Thread End to Thread End of Coupling, L, min
1/8	0.688 (17.48)	0.38 (9.65)	0.625 (15.88)	0.215 (5.46)	0.118	0.645 (16.40)	0.813 (20.65)
1/4	0.812 (20.63)	0.50 (12.70)	0.688 (17.48)	0.302 (7.67)	0.149	0.840 (21.30)	1.063 (27.00)
3/8	0.938 (23.83)	0.50 (12.70)	0.750 (19.05)	0.423 (10.74)	0.160	1.000 (25.40)	1.063 (27.00)
1/2	1.125 (28.58)	0.64 (16.26)	0.750 (19.05)	0.550 (13.97)	0.185	1.280 (32.50)	1.344 (34.14)
3/4	1.250 (31.75)	0.65 (16.51)	1.000 (25.40)	0.750 (19.05)	0.195	1.500 (38.10)	1.500 (38.10)
1	1.500 (38.10)	0.81 (20.57)	1.125 (28.58)	0.960 (24.38)	0.225	1.810 (45.97)	1.688 (42.88)
1 1/4	1.750 (44.45)	0.85 (21.59)	1.313 (33.35)	1.280 (32.51)	0.261	2.200 (55.88)	1.750 (44.45)
1 1/2	1.938 (49.23)	0.85 (21.54)	1.438 (36.53)	1.500 (38.10)	0.270	2.500 (63.50)	2.000 (50.80)
2	2.250 (57.15)	0.90 (22.86)	1.625 (41.28)	1.940 (49.28)	0.297	3.000 (76.20)	2.063 (52.40)
2 1/2	2.688 (68.28)	1.21 (30.73)	1.938 (49.23)	2.320 (58.93)	0.345	3.580 (90.42)	2.625 (66.68)
3	3.063 (77.80)	1.30 (33.02)	2.125 (53.48)	2.900 (73.66)	0.405	4.300 (104.22)	2.750 (69.85)
4	3.625 (92.08)	1.38 (35.05)	2.625 (66.68)	3.830 (97.28)	0.450	5.430 (137.92)	3.000 (76.20)
6	5.125 (130.18)	1.50 (38.10)	3.250 (82.55)	5.761 (146.33)	0.540	7.625 (193.68)	3.250 (82.55)

<sup>A</sup> The sketches and designs of fittings shown are illustrative only.

<sup>B</sup> This dimension locates the end of the fitting.

6.1.5 The minimum inside diameter of the fittings shall be not less than the minimum specified inside diameter of the corresponding size of Schedule 80 pipe.

6.1.6 Minimum dimensions have zero negative tolerance. Tolerances on other dimensions are shown in Table 1 and Table 3.

6.2 *Threads*—For all fittings having taper pipe threads, threads shall conform to Specification F 1498 and be gaged in accordance with 8.4.

6.3 *Burst Pressure*:

6.4 Fittings tested in accordance with 8.5 shall withstand the minimum burst pressure shown in Table 5.

6.4.1 Pressures shown are minimum burst pressures and do not imply rated working pressures. The burst pressure shall be used only as an indication of quality.

## 7. Workmanship, Finish, and Appearance

7.1 The fittings shall be homogeneous throughout and free of cracks, holes, foreign inclusions, or other defects. The fittings shall be as uniform as commercially practicable in color, opacity, density, and other physical properties.

## 8. Test Methods

8.1 *Conditioning*—Condition the test specimens at 73.4 ± 3.6°F (23 ± 2°C) and 50 ± 5 % relative humidity for not less than 40 h prior to test in accordance with Procedure A of Practice D 618, for those tests where conditioning is required.

8.2 *Test Conditions*—Conduct tests in the Standard Laboratory Atmosphere of 73.4 ± 3.6°F (23 ± 2°C) and 50 ± 5 % relative humidity, unless otherwise specified in the test methods or in this specification.

8.3 *Sampling*—A sufficient quantity of fittings as agreed upon between the seller and the purchaser shall be selected at random from each lot or shipment and tested to determine that the basic design is in conformance with this specification.

NOTE 4—For individual orders or specifications where supplemental tests are required, only those tests and numbers of tests specifically agreed upon between purchaser and seller need be conducted.

8.4 *Threads*—All taper pipe threads shall be gaged in accordance with Specification F 1498.

8.5 *Burst Pressure*—Determine the minimum burst pressure in accordance with Test Method D 1599. The pressure shall be applied at a uniform rate such that the minimum allowable burst pressure is attained in 60 to 70 s.

NOTE 5—The time-to-failure may exceed 70 s.

## 9. Retest and Rejection

9.1 If the results of any test(s) do not meet the requirements of this specification, the tests(s) shall be conducted again only by agreement between the purchaser and seller. Under such agreement, minimum requirements shall not be lowered, changed, or modified, nor shall specification limits be changed. If upon retest, failure occurs, the quantity of product represented by the test(s) does not meet the requirements of this specification.

**TABLE 3 Minimum Dimensions from Center to End of Sockets (Laying Length) for Couplings, Tees, 90° and 45° Elbows, PVC Socket-Type Pipe Fittings, Schedule 80, in. (mm)<sup>A</sup>**

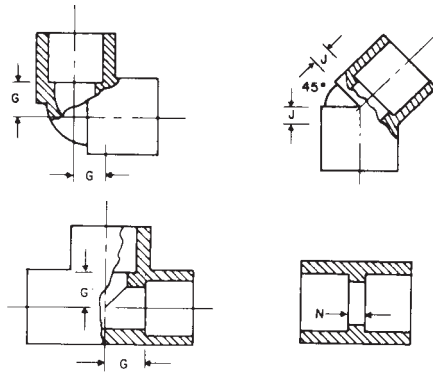

Nominal Pipe Size	G, min	J, min	N, min
1/8	1/4 (6.35)	1/8 (3.18)	1/16 (1.59)
1/4	5/16 (7.94)	5/32 (3.97)	1/16 (1.59)
3/8	3/8 (9.53)	3/16 (4.76)	3/32 (2.38)
1/2	1/2 (12.70)	1/4 (6.35)	3/32 (2.38)
3/4	9/16 (14.29)	5/16 (7.94)	3/32 (2.38)
1	11/16 (17.46)	5/16 (7.94)	3/32 (2.38)
1 1/4	7/8 (22.22)	3/8 (9.53)	3/32 (2.38)
1 1/2	1 (25.40)	7/16 (11.11)	3/32 (2.38)
2	1 1/4 (31.75)	3/8 (9.53)	3/32 (2.38)
2 1/2	1 1/2 (38.10)	11/16 (17.46)	3/16 (4.76)
3	1 13/16 (46.04)	3/4 (19.05)	3/16 (4.76)
3 1/2	2 1/8 (53.98)	1 (25.40)	3/16 (4.76)
4	2 5/16 (58.74)	1 (25.40)	3/16 (4.76)
5	3 (76.20)	1 3/8 (34.93)	3/16 (4.76)
6	3 1/2 (88.90)	1 3/4 (44.45)	1/4 (6.35)
8	4 1/2 (114.30)	2 (50.80)	1/4 (6.35)
10	5 1/16 (144.46)	2 1/4 (57.15)	1/4 (6.35)
12	6 7/8 (174.63)	2 1/2 (63.50)	3/8 (9.53)

<sup>A</sup> The sketches and designs of fittings are illustrative only (taken from Symbols D 2749).

**10. Product Marking**

10.1 *Quality of Marking*—The markings shall be applied to the fittings in such a manner that they remain legible under normal handling and installation practices.

10.2 *Content of Marking*—Fittings shall be marked with the following:

10.2.1 Material designation PVC I for PVC 12454-B, PVC 12 for PVC 12454-C, PVC 13 for PVC 13354-C and 11443-B, and PVC II for PVC 14333-D,

10.2.2 The seal or mark of the laboratory making the evaluation for potable water contact,

10.2.3 Size, and

10.2.4 This designation, D 2467, with which the fitting complies.

10.3 Where the size of the fitting does not allow complete marking, omit identification marking in the following sequence: size, material designation (D 2467), manufacturer’s name, or trademark.

10.4 Marking or symbols shall be molded, hot-stamped, or applied to fittings by any other suitable method, such as printing.

10.5 Where recessed marking is used, care shall be taken to see that in no case does marking causes cracks or reduces the wall thickness below the minimum specified.

**11. Quality Assurance**

11.1 *Quality Assurance*—When the product is marked with this designation, D 2467, the manufacturer affirms that the product was inspected, sampled, and tested in accordance with this specification and has been found to meet the requirements of this specification.

TABLE 4 Symbols for Dimensions of Reducer Bushings, PVC Socket-Type Pipe Fittings, Schedule 80,<sup>A</sup> in. (mm)

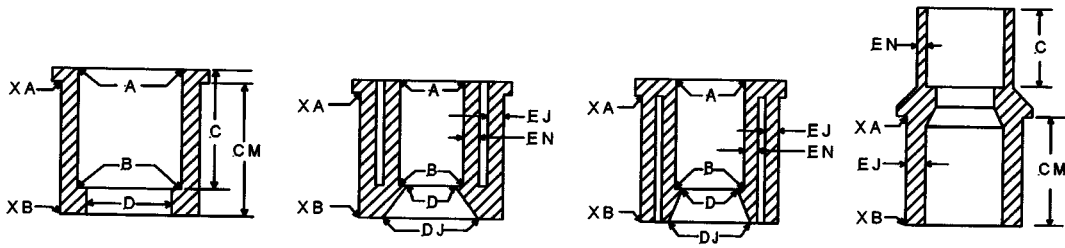

Nominal Size	Outside Diameter XA	Tolerance on Outside Diameter	Outside Diameter XB	Tolerance on Outside Diameter	Maximum Out-of-Roundness (max., minus min.)
1/4 by 1/8	0.540 (13.72)	+0.007 - 0.004 (0.18 - 0.10)	0.540 (13.72)	±0.004 (0.10)	0.016 (0.41)
1/4 by 1/8	0.540 (13.72)	+0.007 - 0.004 (0.18 - 0.10)	0.540 (13.72)	±0.004 (0.10)	0.016 (0.41)
3/8 by 1/4, 1/8	0.675 (17.41)	+0.007 - 0.004 (0.18 - 0.10)	0.675 (17.41)	±0.004 (0.10)	0.016 (0.41)
3/8 by 1/4, 1/8	0.675 (17.41)	+0.007 - 0.004 (0.18 - 0.10)	0.675 (17.41)	±0.004 (0.10)	0.016 (0.41)
1/2 by 3/8, 1/4	0.840 (21.34)	+0.007 - 0.004 (0.18 - 0.10)	0.840 (21.34)	±0.004 (0.10)	0.016 (0.41)
1/2 by 3/8, 1/4	0.840 (21.34)	+0.007 - 0.004 (0.18 - 0.10)	0.840 (21.34)	±0.004 (0.10)	0.016 (0.41)
3/4 by 1/2, 3/8, 1/4	1.050 (26.67)	+0.007 - 0.004 (0.18 - 0.10)	1.050 (26.67)	±0.004 (0.10)	0.020 (0.51)
3/4 by 1/2, 3/8, 1/4	1.050 (26.67)	+0.007 - 0.004 (0.18 - 0.10)	1.050 (26.67)	±0.004 (0.10)	0.020 (0.51)
1 by 1/2, 3/4	1.315 (33.40)	+0.008 - 0.005 (0.20 - 0.13)	1.315 (33.40)	±0.005 (0.13)	0.020 (0.51)
1 1/4 by 1/2, 3/4, 1	1.660 (42.16)	+0.008 - 0.005 (0.20 - 0.13)	1.660 (42.16)	±0.005 (0.13)	0.024 (0.61)
1 1/2 by 1/2, 3/4, 1, 1 1/4	1.900 (48.26)	+0.010 - 0.006 (0.25 - 0.15)	1.900 (48.26)	±0.006 (0.15)	0.024 (0.61)
2 by 1/2, 3/4, 1, 1 1/4, 1 1/2	2.375 (60.33)	+0.010 - 0.006 (0.25 - 0.15)	2.375 (60.33)	±0.006 (0.15)	0.024 (0.61)
2 1/2 by 2	2.875 (73.03)	+0.012 - 0.007 (0.30 - 0.18)	2.875 (73.03)	±0.007 (0.18)	0.030 (0.76)
3 by 2 1/2, 2	3.500 (88.90)	+0.013 - 0.008 (0.33 - 0.20)	3.500 (88.90)	±0.008 (0.20)	0.030 (0.76)
3 1/2 by 2 1/2, 2	4.000 (101.60)	+0.013 - 0.008 (0.33 - 0.20)	4.000 (101.60)	±0.008 (0.20)	0.030 (0.76)
4 by 3 1/2, 3, 2 1/2, 2	4.500 (114.30)	+0.015 - 0.009 (0.38 - 0.23)	4.500 (114.30)	±0.009 (0.23)	0.030 (0.76)
5 by 4	5.563 (141.30)	+0.017 - 0.010 (0.43 - 0.25)	5.563 (141.30)	±0.010 (0.25)	0.060 (1.52)
6 by 5	6.625 (168.28)	+0.018 - 0.011 (0.46 - 0.28)	6.625 (168.28)	±0.011 (0.28)	0.070 (1.78)
8 by 6	8.625 (219.08)	+0.025 - 0.015 (0.64 - 0.38)	8.625 (219.08)	±0.015 (0.38)	0.090 (2.29)
10 by 6	10.750 (273.05)	+0.025 - 0.015 (0.64 - 0.38)	10.750 (273.05)	±0.015 (0.38)	0.100 (2.54)
10 by 8	10.750 (273.05)	+0.025 - 0.015 (0.64 - 0.38)	10.750 (273.05)	±0.015 (0.38)	0.100 (2.54)
12 by 6	12.750 (323.85)	+0.025 - 0.015 (0.64 - 0.38)	12.750 (323.85)	±0.015 (0.38)	0.120 (3.05)
12 by 8	12.750 (323.85)	+0.025 - 0.015 (0.64 - 0.38)	12.750 (323.85)	±0.015 (0.38)	0.120 (3.05)
12 by 10	12.750 (323.85)	+0.025 - 0.015 (0.64 - 0.38)	12.750 (323.85)	±0.015 (0.38)	0.120 (3.05)

<sup>A</sup> The sketches and designs of fittings are illustrative only (taken from Symbols D 2749).

TABLE 5 Dimensions of Plugs and Caps, in.



Nominal Pipe Size	Length of Male Thread, S, min	Length of Female Thread, T, min	Width of Flats, <sup>A</sup> Q, min	Nominal Wall Thickness, F, min	Height of Head, R, min	Cap Height, W, min	Outside Diameter of Band Hub, M, min
1/8	0.31 (7.87)	0.38 (9.65)	0.469 (11.19)	0.108 (2.74)	0.188 (4.76)	0.625 (15.88)	0.645 (16.38)
1/4	0.44 (11.18)	0.50 (12.70)	0.625 (15.88)	0.135 (3.43)	0.188 (4.76)	0.688 (17.48)	0.840 (21.34)
3/8	0.44 (11.18)	0.50 (12.70)	0.750 (19.05)	0.144 (3.66)	0.188 (4.76)	0.688 (17.48)	1.000 (25.40)
1/2	0.53 (13.45)	0.64 (16.26)	0.938 (23.83)	0.198 (5.03)	0.188 (4.76)	0.875 (22.23)	1.280 (32.51)
3/4	0.55 (13.97)	0.65 (16.51)	1.125 (28.58)	0.207 (5.26)	0.219 (5.56)	1.000 (25.40)	1.450 (36.80)
1	0.68 (17.27)	0.81 (20.57)	1.375 (34.93)	0.225 (5.72)	0.219 (5.56)	1.188 (30.18)	1.810 (45.97)
1 1/4	0.71 (18.03)	0.85 (21.59)	1.750 (44.45)	0.261 (6.63)	0.281 (7.14)	1.250 (31.75)	2.200 (55.88)
1 1/2	0.72 (18.29)	0.85 (21.59)	1.875 (47.63)	0.270 (6.86)	0.313 (7.95)	1.250 (31.75)	2.450 (62.23)
2	0.76 (19.30)	0.90 (22.86)	1.875 (47.63)	0.297 (7.54)	0.313 (7.95)	1.375 (34.93)	3.000 (76.20)
2 1/2	1.14 (28.96)	1.21 (30.73)	1.875 (47.63)	0.369 (9.37)	0.375 (9.53)	1.625 (41.28)	3.560 (90.42)
3	1.20 (30.48)	1.30 (33.02)	2.000 (50.80)	0.405 (10.29)	0.375 (9.53)	1.750 (44.45)	4.250 (107.90)
4	1.30 (33.02)	1.38 (35.05)	2.000 (50.80)	0.450 (11.43)	0.375 (9.53)	2.000 (50.80)	5.350 (134.62)
6	1.44 (36.58)	1.50 (38.10)	2.000 (50.80)	0.504 (12.80)	0.500 (12.70)	2.125 (53.98)	7.625 (193.00)

<sup>A</sup> At the manufacturer's option the head of the plug may be hexagonal, octagonal, square, or round. The sketches and designs of fittings shown are illustrative only.

12. Keywords

12.1 blunt start thread; fittings; IPS; PVC; Schedule 80; sockets; thread

**TABLE 6 Burst Pressure Requirements for Water at 73°F (23°C)  
for PVC Socket-Type Pipe Fittings, Schedule 80**

Nominal Size, in.	Minimum Burst Strength			
	Classes 12454, 13354, and 11443		Class 14333	
	psi	MPa	psi	MPa
1/8	3920	27.03	3060	21.10
1/4	3620	24.96	2830	19.51
3/8	2940	20.27	2300	15.86
1/2	2720	18.75	2120	14.62
3/4	2200	15.17	1720	11.36
1	2020	13.93	1580	10.89
1 1/4	1660	11.44	1300	8.96
1 1/2	1510	10.41	1180	8.14
2	1290	8.89	1010	6.96
2 1/2	1360	9.38	1060	7.31
3	1200	8.27	940	6.48
3 1/2	1110	7.65	860	5.93
4	1040	7.17	810	5.58
5	930	6.41	720	4.96
6	890	6.14	700	4.83
8	790	5.45	620	4.27
10	600	4.14	...	...
12	580	4.00	...	...

### SUPPLEMENTARY REQUIREMENTS

#### GOVERNMENT / MILITARY PROCUREMENT

These requirements apply *only* to Federal / Military procurement, not domestic sales or transfers.

**S1. Responsibility for Inspection**—Unless otherwise specified in the contract or purchase order, the producer is responsible for the performance of all inspection and test requirements specified herein. The producer may use his own or any other suitable facilities for the performance of the inspection and test requirements specified herein, unless the purchaser disapproves. The purchaser shall have the right to perform any of the inspections and tests set forth in this specification where such inspections are deemed necessary to ensure that material conforms to prescribed requirements.

NOTE S1.1—In U.S. Federal contracts, the contractor is responsible for inspection.

**S2. Packaging and Marking for U.S. Government Procurement:**

**S2.1 Packaging**—Unless otherwise specified in the contract, the materials shall be packaged in accordance with the supplier’s standard practice in a manner ensuring arrival at destination in satisfactory condition and which will be acceptable to the carrier at lowest rates. Containers and packing shall comply with Uniform Freight Classification rules or National Motor Freight Classification rules.

**S2.2 Marking**—Marking for shipment shall be in accordance with Fed. Std. No. 123 for civil agencies and MIL-STD-129 for military agencies.

NOTE S2.1— The inclusion of U.S. Government procurement requirements should not be construed as an indication that the U.S. Government uses or endorses the products described in this document.

**POTABLE WATER REQUIREMENT**

**This requirement applies whenever a Regulatory Authority or user calls for product to be used to convey or to be in contact with potable water.**

S3. Products intended for contact with potable water shall be evaluated, tested and certified for conformance with ANSI/NSF Standard No. 61 or the health effects portion of NSF Standard No. 14 by an acceptable certifying organization when required by the regulatory authority having jurisdiction.

*ASTM International takes no position respecting the validity of any patent rights asserted in connection with any item mentioned in this standard. Users of this standard are expressly advised that determination of the validity of any such patent rights, and the risk of infringement of such rights, are entirely their own responsibility.*

*This standard is subject to revision at any time by the responsible technical committee and must be reviewed every five years and if not revised, either reapproved or withdrawn. Your comments are invited either for revision of this standard or for additional standards and should be addressed to ASTM International Headquarters. Your comments will receive careful consideration at a meeting of the responsible technical committee, which you may attend. If you feel that your comments have not received a fair hearing you should make your views known to the ASTM Committee on Standards, at the address shown below.*

*This standard is copyrighted by ASTM International, 100 Barr Harbor Drive, PO Box C700, West Conshohocken, PA 19428-2959, United States. Individual reprints (single or multiple copies) of this standard may be obtained by contacting ASTM at the above address or at 610-832-9585 (phone), 610-832-9555 (fax), or [service@astm.org](mailto:service@astm.org) (e-mail); or through the ASTM website ([www.astm.org](http://www.astm.org)).*