



Standard Specification for Solvent Cements for Poly(Vinyl Chloride) (PVC) Plastic Piping Systems¹

This standard is issued under the fixed designation D 2564; the number immediately following the designation indicates the year of original adoption or, in the case of revision, the year of last revision. A number in parentheses indicates the year of last reapproval. A superscript epsilon (ϵ) indicates an editorial change since the last revision or reapproval.

This standard has been approved for use by agencies of the Department of Defense.

1. Scope

1.1 This specification covers requirements for poly(vinyl chloride) (PVC) solvent cements to be used in joining poly(vinyl chloride) piping systems.

1.2 These solvent cements are used with poly(vinyl chloride) piping systems made from compounds as defined in Specifications D 1784, D 3915, and D 4396.

1.3 A procedure for joining PVC pipe and fittings is given in Practice D 2855.

1.4 The text of this specification references notes, footnotes, and appendixes which provide explanatory material. These notes and footnotes (excluding those in tables and figures) shall not be considered as requirements of the specification.

1.5 The values stated in inch-pound units are to be regarded as the standard. The values given in parentheses are for information only.

1.6 The following safety hazards caveat pertains only to the test methods portion, Section 6, of this specification: *This standard does not purport to address all of the safety concerns, if any, associated with its use. It is the responsibility of the user of this standard to establish appropriate safety and health practices and determine the applicability of regulatory limitations prior to use.*

2. Referenced Documents

2.1 ASTM Standards:

D 1084 Test Methods for Viscosity of Adhesives²

D 1600 Terminology for Abbreviated Terms Relating to Plastics³

D 1784 Specification for Rigid Poly(Vinyl Chloride) (PVC) Compounds and Chlorinated Poly(Vinyl Chloride) (CPVC) Compounds³

D 1785 Specification for Poly(Vinyl Chloride) (PVC) Plastic Pipe, Schedules 40, 80, and 120⁴

D 2467 Specification for Socket-Type Poly(Vinyl Chloride)

(PVC) Plastic Pipe Fittings, Schedule 80⁴

D 2855 Practice for Making Solvent-Cemented Joints with Poly(Vinyl Chloride) (PVC) Pipe and Fittings⁴

D 3915 Specification for Poly(Vinyl Chloride) (PVC) and Related Plastic Pipe and Fitting Compounds for Pressure Applications⁵

D 4396 Specification for Rigid Poly(Vinyl Chloride) (PVC) and Related Plastic Compounds for Non-Pressure Piping Products⁶

F 402 Practice for Safe Handling of Solvent Cements, Primers, and Cleaners Used for Joining Thermoplastic Pipe and Fittings⁴

F 412 Terminology Relating to Plastic Piping Systems⁴

F 493 Specification for Solvent Cements for Chlorinated Poly (Vinyl Chloride) (CPVC) Plastic Pipe and Fittings⁴

2.2 National Sanitation Foundation Standards:

Standard No. 14 for Plastic Piping Components and Related Materials⁷

Standard No. 61 for Drinking Water Systems Components—Health Effects⁷

3. Terminology

3.1 *Definitions*—Definitions are in accordance with Terminology F 412, and abbreviations are in accordance with Terminology D 1600, unless otherwise specified.

4. Materials and Manufacture

4.1 The solvent cement shall be a solution of the base PVC resin used to make Class 12454-B poly(vinyl chloride) molding or extrusion compound as defined in Specification D 1784.

4.2 When rework material is used, the manufacturer shall use only his own clean rework material that is compatible with virgin material and produces a cement that meets the requirements of this specification.

4.3 The cement shall be free-flowing and shall not contain lumps, macroscopic undissolved particles, or any foreign matter that will adversely affect the ultimate joint strength or chemical resistance of the cement.

¹ This specification is under the jurisdiction of ASTM Committee F-17 on Plastic Piping Systems and is the direct responsibility of Subcommittee F17.20 on Joining. Current edition approved Sept. 10, 1996. Published November 1996. Originally published as D2564 – 66 T. Last previous edition D2564 – 96.

² *Annual Book of ASTM Standards*, Vol 15.06.

³ *Annual Book of ASTM Standards*, Vol 08.01.

⁴ *Annual Book of ASTM Standards*, Vol 08.04.

⁵ *Annual Book of ASTM Standards*, Vol 08.02.

⁶ *Annual Book of ASTM Standards*, Vol 08.03.

⁷ Available from the National Sanitation Foundation, P.O. Box 1468, Ann Arbor, MI 48106.

4.4 The cement shall show no gelation. It shall show no stratification or separation that cannot be removed by stirring or shaking.

4.5 When inert fillers are added, the resulting cement shall meet all requirements of this specification.

4.6 The particular solvent system to be used in the formulation of this solvent cement is not specified, since it is recognized that a number of adequate solvent systems for PVC exist. Solvent systems consisting of blends of tetrahydrofuran and cyclohexanone have been found to make cements that are acceptable under the requirements of this specification.

NOTE 1—It is recommended that solvent cements made to this specification *not* be orange since that color is recommended for use with CPVC solvent cement under Specification F 493.

5. Requirements

5.1 *Resin Content*—The PVC resin content shall be 10 % minimum when tested in accordance with 6.1.

5.2 *Dissolution*—The cement shall be capable of dissolving an additional 3 % by weight of PVC 12454-B compound (either powder or granular) or the equivalent PVC resin at 73.4 ± 3.6°F (23 ± 2°C) without evidence of gelation.

5.3 *Viscosity*—Cements are classified as regular-, medium-, or heavy-bodied types, based on their minimum viscosity when tested in accordance with 6.1.1.

5.3.1 Regular-bodied cements shall have a minimum viscosity of 90 cP (90 MPa·s).

5.3.2 Medium-bodied cements shall have a minimum viscosity of 500 cP (500 MPa·s).

5.3.3 Heavy-bodied cements shall have a minimum viscosity of 1600 cP (1600 MPa·s).

NOTE 2—Refer to Appendix X1 for guidelines in selecting PVC solvent cements for joining different pipe sizes.

5.4 *Lap Shear Strength*—The minimum average lap shear strength, when tested in accordance with 6.3.2, shall be 250 psi (1.7 MPa) after a 2-h curing time, 500 psi (3.4 MPa) after a 16-h curing time, and 900 psi (6.2 MPa) after a 72-h curing time.

NOTE 3—These values should not be used for designing piping joints.

5.5 *Hydrostatic Burst Strength*—The minimum average hydrostatic burst strength, when tested in accordance with 6.3.3, shall be 400 psi (2.8 MPa) after a 2-h curing time.

6. Test Methods

6.1 Solids Content:

6.1.1 Apparatus:

6.1.1.1 *Ointment Tins* (Style No. 12, 1-oz (30-mL), all metal).

6.1.1.2 Vacuum Oven.

6.1.1.3 Analytical Balance.

6.1.1.4 Centrifuge.

6.1.2 Procedure:

6.1.2.1 Stir the sample thoroughly with a spatula before weighing (Note 4). Weigh 3.0 ± 0.5 g of the sample to the nearest 1 mg into a tared ointment tin. Place tin into the vacuum oven (Note 5), and heat at 248°F (120°C) for 45 min +15, -0 min. Discard specimens left in for more than 1 h. The vacuum must be continually in operation to draw off flammable

solvents and shall be maintained at 15 mm Hg minimum. Remove the tin from the oven and place in a desiccator until cooled to room temperature. Weigh the tin and dried sample to the nearest 1 mg.

NOTE 4—This material is usually nonhomogeneous and shall be thoroughly stirred before weighing. The weighing shall also be accomplished quickly to avoid loss of solvent by volatilization.

NOTE 5—The use of a vacuum oven is mandatory for drying the specimen, because this oven has neither an exposed heating surface nor an open flame, thus avoiding the danger of flashing. The oven also provides an open vacuum to exhaust solvent fumes.

6.1.2.2 After weighing, dissolve most of the dried sample by adding 15 mL of tetrahydrofuran (THF) to the sample in the ointment tin and stirring with a glass rod for 15 min. Collect the liquid decanted from this step, plus the liquid from the next two steps. Dissolve the remainder with a second addition of 15 mL of THF, followed by a third addition of 5 mL of THF to rinse the ointment tin. Centrifuge the entire volume at 20 000 r/min for 15 min. Discard the supernatant liquid. Add 15 mL of THF to the tube, mix thoroughly, and transfer the tube contents to the ointment tin. Use 2 mL more of THF to wash down the tube, and pour into the ointment tin. Evaporate off the THF in the vacuum oven at 248°F (120°C) for 45 min. Cool in desiccator, weigh the tin to the nearest 1 mg, and calculate the percent of inert filler present in the cement.

6.1.3 *Calculation*—Calculate the percentage of PVC resin as follows:

$$\text{Resin, \%} = [(B - A - D)/(C - A)] \times 100 \quad (1)$$

where:

A = weight of ointment tin,

B = weight of tin and specimen after drying,

C = weight of tin and specimen before drying, and

D = weight of inert filler, if present.

NOTE 6—Other methods for determination of resin and inert filler content may be used provided the results of the alternative method are as accurate and consistent as the above method.

6.2 *Viscosity*—Measure the viscosity in accordance with Method B of Test Methods D 1084, except that conditioning to temperature equilibrium only is required. For qualification purposes, use a Model RVF viscometer, a speed of 10 r/min, and the spindle that, by trial, gives the closest reading to center range of scale for the cement being tested. Other speeds are also used for quality control purposes.

6.3 Bond Strength:

6.3.1 *Number of Specimens*—A minimum of five specimens shall be tested for each requirement of 5.4 and 5.5.

6.3.2 Lap Shear Strength:

6.3.2.1 Cut 1 by 1-in. (25 by 25-mm) and 1 by 2-in. (25 by 50-mm) sections from ¼-in. (6-mm) thick sheet made from Class 12454-B PVC. One section of each size is required for each test specimen (Fig. 1).

6.3.2.2 Clean the surfaces to be adhered with a cloth dampened with methyl ethyl ketone (MEK).

6.3.2.3 Using a 1-in. (25-mm) bristle brush, apply a thin layer of cement to the complete surface of a 1 by 1-in. (25 by 25-mm) sheet section and to the center of a 1 by 2-in. (25 by

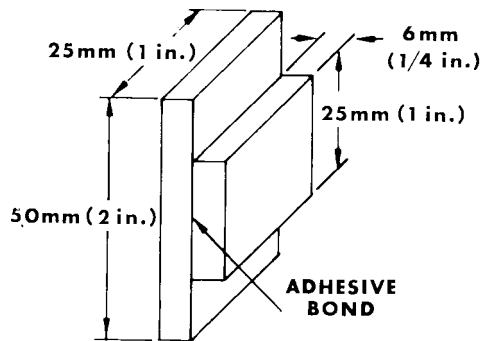

FIG. 1 Compression Shear Specimen

50-mm) sheet section.

6.3.2.4 Assemble these sections immediately and rotate the 1 by 1-in. (25 by 25-mm) section 180° on the 1 by 2-in. (25 by 50-mm) section, within 5 s, using light hand pressure (approximately 0.5 lb (2 N)).

6.3.2.5 Place the assembled test specimen on a clean, level surface using the 1 by 2-in. (25 by 50-mm) section as a base. After 30 s, place a 2-kg weight on the test specimen for a period of 3 min, then remove.

6.3.2.6 Store the assembled test specimens at $73.4 \pm 3.6^\circ\text{F}$ ($23 \pm 2^\circ\text{C}$) for the specified time and test immediately in a holding fixture similar to that shown in Fig. 2. The shear speed shall be 0.05 in. (1.25 mm)/min. Express the results in pounds per square inch (or megapascals).

6.3.3 Hydrostatic Burst Strength:

6.3.3.1 Use 2-in. (50-mm) PVC Schedule 80 pipe meeting the requirements of Specification D 1785 and PVC Schedule 80 couplings meeting the requirements of Specification D 2467, except that the socket depth shall be 1.5 in. (38 mm). The dimensions of the pipe and fitting socket shall be such that the pipe will enter the socket from one third to two thirds of the full socket depth dry when assembled by hand.

6.3.3.2 Cut the pipe into 6-in. (150-mm) lengths and join to the couplings as in Practice D 2855 except only wipe with a clean dry rag. The pipe must be fully bottomed in the fitting socket.

NOTE 7—Do not apply cleaner or primer since the purpose of the test is to evaluate the cement, alone.

6.3.3.3 Close the ends of the test specimens with suitable end closures for pressure testing.

6.3.3.4 Store the specimens at $73.4 \pm 3.6^\circ\text{F}$ ($23 \pm 2^\circ\text{C}$) for $2 \text{ h} \pm 5 \text{ min}$; then test immediately.

6.3.3.5 Increase the internal hydrostatic pressure at the rate of 200 psi (1.4 MPa)/min $\pm 10 \%$ until failure occurs.

7. Retest and Rejection

7.1 If the results of any test(s) do not meet the requirements of this specification, the test(s) shall be conducted again only

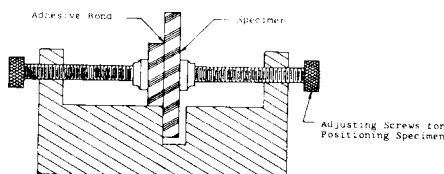

FIG. 2 Typical Specimen-Holding Device

by agreement between the purchaser and the seller. Under such agreement, minimum requirements shall not be lowered, nor tests omitted, substituted, changed, or modified, nor shall specification limits be changed. If upon retest, failure occurs, the quantity of product represented by the test(s) does not meet the requirements of this specification.

8. Report

8.1 Report the following information:

8.1.1 Name of cement manufacturer,

8.1.2 Lot number,

8.1.3 Total PVC resin, % *W*,

8.1.4 Dissolution, pass or fail,

8.1.5 Viscosity,

8.1.6 Average lap shear strength at each cure time and complete identification of PVC sheet stock used for tests,

8.1.7 Average hydrostatic burst strength, and

8.1.8 Total inert filler, % *W*.

9. Certification

9.1 When specified in the purchase order, the manufacturer shall certify to the buyer or to his nominee that the products in the specified lots meet all the requirements of this specification and when requested, shall include a copy of the manufacturer's routine quality control tests results to document that the specification requirements have been met. Each certification so furnished shall be signed by an authorized agent of the manufacturer.

10. Container Labeling and Marking

10.1 Container labeling of cement shall include the following:

10.1.1 Manufacturer's or supplier's name and address and tradename or trademark,

10.1.2 This designation: ASTM D 2564,

10.1.3 Function of material (cement for PVC pipe and fittings),

10.1.4 Cement type according to viscosity as shown in the detail requirements of 5.3,

NOTE 8—It is recommended that the manufacturer's label show the pipe sizes for which the cement is recommended.

10.1.5 Procedure or instructions for application of the cement,

10.1.6 Lot number of batch on container (not on closure or lid),

NOTE 9—Solvent cement intended for use in the joining of potable water piping should be evaluated and certified as safe for this purpose by a testing agency acceptable to the local health authority. The evaluation should be in accordance with requirements for chemical extraction, taste, and odor that are no less restrictive than those included in NSF Standard No. 14. The seal or mark of the laboratory making the evaluation should be included on the container.

10.1.7 End use application (examples: potable water and non-pressure uses), and

10.1.8 All warnings and cautions necessitated by the following:

10.1.8.1 Ingredients,

10.1.8.2 Handling and distribution of the product,



10.1.8.3 Intended use, and

10.1.8.4 Requirements of law (including the Federal Hazardous Substance Act and the OSHA Hazard Communication Act.)

10.1.8.5 These are intended to warn those who handle or use the product against potential hazards, such as flammability, toxicity, etc.

NOTE 10—It is recommended that the color of the contents be indicated on the label.

11. Safe Handling of Solvent Cement

11.1 Solvent cements for plastic pipe are made from flammable liquids. Keep them away from all sources of ignition.

Maintain ventilation to reduce fire hazard and to minimize breathing of solvent vapors. Avoid contact of cement with skin and eyes.

11.2 Refer to Practice F 402 for additional information.

12. Quality Assurance

12.1 When the product is marked with this designation, D 2564, the manufacturer affirms that the product was manufactured, inspected, sampled, and tested in accordance with this specification and has been found to meet the requirements of this specification.

SUPPLEMENTARY REQUIREMENTS

This requirement applies whenever a regulatory authority or user calls for the product to be used to convey or to be in contact with potable water.

S1. *Potable Water Requirement*—Products intended for contact with potable water shall be evaluated, tested, and certified for conformance with ANSI/NSF Standard No. 61 or

the health effects portion of NSF Standard No. 14 by an acceptable certifying organization when required by the regulatory authority having jurisdiction.

APPENDIX

(Nonmandatory Information)

X1. GUIDE FOR PVC SOLVENT CEMENT SELECTION

X1.1 The successful joining of PVC pipes and fittings larger than 2 in. and all non-interference-type joints requires the use of solvent cements that have higher gap-filling properties than the minimum viscosity (90 cP) cements permitted in this specification. The ability of a solvent cement to fill a gap in a pipe joint can be determined by considering its viscosity and wet-film thickness (Note X1.1). A guide to the proper selection of a solvent cement for the various pipe sizes is given in Table X1.1 and Table X1.2 where cements are classified (for purposes of identification) into three types as regular-bodied, medium-bodied, or heavy-bodied, based on minimum viscosity and wet-film thickness.

X1.1.1 Manufacturers' recommendations for pipe size application should be followed, for guidelines shown in the tables are general ones. Note that solvent cement properties may vary considerably among manufacturers. There are also situations where joint fits vary for different applications of the same nominal pipe size. In such cases, variations from the guidelines

TABLE X1.2 PVC Cements for Schedule 80 and Noninterference Fits (See Note X1.2 and Note X1.3)

Pipe Size Range, in.	Cement Type	Minimum Viscosity		Wet Film Thickness, min	
		cP	(mPa·s)	in.	(mm)
1/8 to 1/4	medium-bodied	500	(500)	0.012	(0.30)
1/2 to 6	heavy-bodied	1600	(1600)	0.024	(0.60)

given in Table X1.1 and Table X1.2 may be satisfactory and desirable.

NOTE X1.1—The wet-film thickness of a solvent cement can be measured by using a Nordson Wet Film Thickness Gage or equivalent, available from Nordson Corp., Amherst, OH 44001, as Nordson No. 79-0015. To use this gage, dip a short length of 1-in. pipe vertically into the cement at a temperature of approximately 73°F (23°C) to a depth of 1.5 to 2 in. (40 to 50 mm) for a period of 15 s. Remove the pipe from the cement and hold the pipe horizontally for 45 s. Measure the wet-film thickness on the top surface of the pipe with the end of the gage about 1/4 in. (10 mm) from the end of the pipe. With a little care and experience the wet cement layer can be readily measured to ±0.002 in. (±0.05 mm).

NOTE X1.2—Medium-bodied and heavy-bodied cement can generally be used for smaller pipe sizes than that shown in Table X1.1 and Table X1.2.

NOTE X1.3—The solvent cement manufacturer's recommendations should be followed in selecting the proper cement for joining Schedule 80 pipe size above 6 in.

TABLE X1.1 PVC Cements for Schedule 40 and Interference Fit (See Note X1.2)

Pipe Size Range, in.	Cement Type	Minimum Viscosity		Wet Film Thickness, min	
		cP	(mPa·s)	in.	(mm)
1/8 to 2	regular-bodied	90	(90)	0.006	(0.15)
2 1/2 to 6	medium-bodied	500	(500)	0.012	(0.30)
8 to 12	heavy-bodied	1600	(1600)	0.024	(0.60)

NOTICE: This standard has either been superseded and replaced by a new version or discontinued. Contact ASTM International (www.astm.org) for the latest information.



ASTM International takes no position respecting the validity of any patent rights asserted in connection with any item mentioned in this standard. Users of this standard are expressly advised that determination of the validity of any such patent rights, and the risk of infringement of such rights, are entirely their own responsibility.

This standard is subject to revision at any time by the responsible technical committee and must be reviewed every five years and if not revised, either reapproved or withdrawn. Your comments are invited either for revision of this standard or for additional standards and should be addressed to ASTM International Headquarters. Your comments will receive careful consideration at a meeting of the responsible technical committee, which you may attend. If you feel that your comments have not received a fair hearing you should make your views known to the ASTM Committee on Standards, at the address shown below.

This standard is copyrighted by ASTM International, 100 Barr Harbor Drive, PO Box C700, West Conshohocken, PA 19428-2959, United States. Individual reprints (single or multiple copies) of this standard may be obtained by contacting ASTM at the above address or at 610-832-9585 (phone), 610-832-9555 (fax), or service@astm.org (e-mail); or through the ASTM website (www.astm.org).