



Standard Specification for Type PSM Poly(Vinyl Chloride) (PVC) Sewer Pipe and Fittings¹

This standard is issued under the fixed designation D 3034; the number immediately following the designation indicates the year of original adoption or, in the case of revision, the year of last revision. A number in parentheses indicates the year of last reapproval. A superscript epsilon (ϵ) indicates an editorial change since the last revision or reapproval.

This standard has been approved for use by agencies of the Department of Defense.

1. Scope

1.1 This specification covers requirements and test methods for materials, dimensions, workmanship, flattening resistance, impact resistance, pipe stiffness, extrusion quality, joining systems and a form of marking for type PSM poly(vinyl chloride) (PVC) sewer pipe and fittings.

1.2 Pipe and fittings produced to this specification should be installed in accordance with Practice D 2321.

1.3 The text of this specification references notes, footnotes, and appendixes which provide explanatory material. These notes and footnotes (excluding those in tables and figures) shall not be considered as requirements of the specification.

1.4 The values stated in inch-pound units are to be regarded as the standard. The values given in parentheses are for information only.

1.5 The following precautionary caveat pertains only to the test methods portion, Section 8, of this specification: *This standard does not purport to address all of the safety concerns, if any, associated with its use. It is the responsibility of the user of this standard to establish appropriate safety and health practices and determine the applicability of regulatory limitations prior to use.*

2. Referenced Documents

2.1 ASTM Standards:

D 618 Practice for Conditioning Plastics and Electrical Insulating Materials for Testing²

¹ This specification is under the jurisdiction of ASTM Committee F-17 on Plastic Piping Systems and is the direct responsibility of Subcommittee F17.62 on Sewer. Current edition approved April 10, 1998; 2000. Published November 1998; August 2000. Originally published as D 3034 – 72. Last previous edition D 3034 – 97.

- D 1600 Terminology for Abbreviated Terms Relating to Plastics^{2,3}
- D 1784 Specification for Rigid Poly(Vinyl Chloride) (PVC) Compounds and Chlorinated Poly(Vinyl Chloride) (CPVC) Compounds²
- D 2122 Test Method for Determining Dimensions of Thermoplastic Pipe and Fittings³

² *Annual Book of ASTM Standards*, Vol 08.01.

³ *Annual Book of ASTM Standards*, Vol 08.04.

- D 2152 Test Method for ~~Degree Adequacy~~ of Fusion of Extruded Poly(Vinyl Chloride) (PVC) Pipe and Molded Fittings by Acetone Immersion³
- D 2321 Practice for Underground Installation of Thermoplastic Pipe for Sewers and Other Gravity-Flow Applications³
- D 2412 Test Method for Determination of External Loading Characteristics of Plastic Pipe by Parallel-Plate Loading³
- D 2444 Test Method for Impact Resistance of Thermoplastic Pipe and Fittings by Means of a Tup (Falling Weight)³
- D 2564 Specification for Solvent Cements for Poly(Vinyl Chloride) (PVC) Plastic Piping Systems³
- D 2749 Symbols for Dimensions of Plastic Pipe Fittings³
- D 2855 Practice for Making Solvent-Cemented Joints with Poly(Vinyl Chloride) (PVC) Pipe and Fittings³
- D 3212 Specification for Joints for Drain and Sewer Plastic Pipes Using Flexible Elastomeric Seals³
- F 412 Terminology Relating to Plastic Piping Systems³
- F 1336 Specification for Poly(Vinyl Chloride) (PVC) Gasketed Sewer Fittings³
- 2.2 *Federal Standard*:⁴
- Fed. Std. No. 123 Marking for Shipment (Civil Agencies)
- 2.3 *Military Standard*:⁴
- MIL-STD-129 Marking for Shipment and Storage

3. Terminology

- 3.1 ~~Definitions~~*Definitions*— Definitions are in accordance with Terminology F 412, and abbreviations are in accordance with Terminology D 1600, unless otherwise specified. The abbreviation of poly(vinyl chloride) plastics is PVC.
 - 3.1.1 The term PSM is not an abbreviation but rather an arbitrary designation for a product having certain dimensions.

4. Significance and Use

4.1 The requirements of this specification are intended to provide pipe and fittings suitable for non-pressure drainage of sewage and surface water.

NOTE 1—Industrial waste disposal lines should be installed only with the specific approval of the cognizant code authority since chemicals not commonly found in drains and sewers and temperatures in excess of 60°C (140°F) may be encountered.

5. Materials

- 5.1 ~~Basic Materials—The pipe~~*Basic Materials*
- 5.1 Pipe shall be made of PVC plastic having a cell classification of 12454 or 12364 as defined in Specification D 1784.~~The~~
f
- 5.2 Fittings shall be made of PVC plastic having a cell classification of 12454 or 13343 as defined in Specification D 1784.
- 5.3 Pipe and Fitting— Compounds that have different cell classifications, because one or more properties are superior to those of the specified compounds, are also acceptable.
- 5.24 Rework Material— The manufacturer shall use only his own clean pipe or fitting rework material; the pipe and fittings produced shall meet all the requirements of this specification.

6. Joining Systems

- 6.1 Solvent Cement Joints for Pipe and Fittings—In the solvent cement joint, the pipe spigot wedges into the tapered socket and the surfaces fuse together. The tapered socket may be a portion of a molded fitting or it may be a belled end of the pipe section. Formed bells shall be concentric with the pipe axis.
 - 6.1.1 The assembly of joints shall be in accordance with Practice D 2855.
 - 6.1.2 Joint Tightness— Joints made with pipe and fittings or with belled-end pipe shall show no signs of leakage when tested in accordance with 8.9.
- 6.2 Elastomeric Gasket Joints, providing a water-tight seal.
 - 6.2.1 The assembly of elastomeric gasket joints shall be in accordance with the pipe ~~manufacturer's recommendations~~ and Specification D 3212. fittings manufacturer's recommendations.

7. Requirements

- 7.1 Workmanship— The pipe and fittings shall be homogeneous throughout and free from visible cracks, holes, foreign inclusions, or other injurious defects. The pipe shall be as uniform as commercially practical in color, opacity, density, and other physical properties.
- 7.2 Pipe ~~Dimensions~~ Requirements:
 - 7.2.1 Diameter—The average outside diameter of the pipe shall meet the requirements given in Table 1 when measured in accordance with 8.4.1.

⁴ Available from Standardization Documents Order Desk, Bldg. 4 Section D, 700 Robbins Ave., Philadelphia, PA 19111-5094, Attn: NPODS.

TABLE 1 Pipe Dimensions

Nominal Size	Outside Diameter		Minimum Wall Thickness ^A			
	Average	Tolerance on Average	SDR 41	SDR 35	SDR 26	SDR 23.5
4	4.215	±0.009	...	0.120	0.162	0.178
4	4.215	±0.009	...	0.120	0.162	0.178
6	6.275	±0.011	0.153	0.180	0.244	0.265
6	6.275	±0.011	0.153	0.180	0.241	0.265
8	8.400	±0.012	0.205	0.240	0.323	...
8	8.400	±0.012	0.205	0.240	0.323	...
9	9.440	±0.014	0.230
9	9.440	±0.014	0.230
10	10.500	±0.015	0.256	0.300	0.404	...
10	10.500	±0.015	0.256	0.300	0.404	...
12	12.500	±0.018	0.305	0.360	0.481	...
12	12.500	±0.018	0.305	0.360	0.481	...
15	15.300	±0.023	0.375	0.437	0.588	...
15	15.300	±0.023	0.375	0.437	0.588	...

^A*Fitting Wall Thickness*—The wall thickness is a minimum value except that a ±10 % variation resulting from core shift is allowable. In such a case, the average of two opposite wall thicknesses shall equal or exceed the value shown in the table.

NOTE 2—As larger sizes of sewer pipe are needed, it is recommended that they be made with the following outside diameters: 475, 560, and 630 mm.

7.2.2 *Wall Thickness*—Pipe wall thicknesses shall meet the requirements of Table 1 when measured in accordance with Test Method D 2122 and 8.4.2. In the case of belled pipe and fittings fabricated from pipe sections, the thickness of the wall in the bell shall be considered satisfactory if it was formed from pipe meeting the above preceding requirements.

7.3 *Socket Dimensions for Solvent Cemented Joints:*

7.3.1 *Socket Diameter*—The inside diameter of the tapered socket shall comply with the dimensions listed in Table 2 when determined in accordance with 8.5.1.

7.3.2 *Socket Depth*—The socket depth shall not be less than that shown in Table 2 when measured in accordance with 8.5.2.

7.4 *Fitting Dimensions:*

7.4.1 *Wall Thickness of Molded Fittings*—The wall thicknesses of the waterway and socket or bell of molded fittings shall be no less than the respective minimum thicknesses listed for the equivalent pipe in Table 1. For reducing fittings or those with smaller inlets, the minimum wall thickness of each inlet shall be no less than the minimum wall thickness for that size pipe. The thickness shall be determined in accordance with Test Method D 2122 and 8.5.3.

7.5
7.5.2.3 *Pipe Flattening*—There shall be no evidence of splitting, cracking, or breaking when pipe is tested in accordance with 8.6.

7.6.2.4 *Pipe Impact Strength*—The impact strength of the pipe shall not be less than the values given in Table 3 when tested in accordance with 8.7.

NOTE 3—This test is intended only for use as a quality control test, not as a simulated service test.

7.7.2.5 *Pipe Stiffness*—Pipe stiffness values for the pipe shall comply with Table 4 when tested in accordance with 8.8.

TABLE 2 Socket Minimum Pipe Impact Strength at 23°C (73°F)

Nominal Pipe Size, in.	A	B	C
4	4.235 ± 0.009	4.210 ± 0.009	1.75
4	20.009	4.23 (10 ± 0.009)	1.750
6	6.305 ± 0.011	6.270 ± 0.011	3.000
6	6.305 ± 0.011	6.284 (21)	3.0
8	8.424 ± 0.012	8.388 ± 0.012	4.000
8	284 (212)	8.388 ± 0.012	4.000
9	9.486 ± 0.014	9.426 ± 0.014	4.500
9	29.486 ± 0.014	9 (220)	4.500
10	10.530 ± 0.015	10.485 ± 0.015	5.000
10	299 (220-530 ± 0.015)	10.485 ± 0.015	5.000
12	12.536 ± 0.018	12.482 ± 0.018	6.000
12	2.536 ± 0.018	12.482 ± 0.018	6.000
15	15.346 ± 0.023	15.277 ± 0.023	7.500
15	23	15.277 ± 0.023	7.500

TABLE 3 Minimum Impact Strength at 23°C (73°F) 5 % Deflection

Pipe Size, in.	Pipe Stiffness, kPa (psi)		
	SDR 41	Impact Strength, J (ft-lbf)	SDR 23.5
35		DR SDR 26	
-4	203 (150)		
4	203 (150)		
...	6	284 (210)	284 (210)
...	320 (46)	790 (115)	1055 (153)
-9	299 (220) ¹⁰	299 (220) ¹²	299 (220)
6 to 15	190 (28)	320 (46)	790
15	299 (220)		
(115)	1055 (153)		

7.8 *Solvent Cement*—The cement shall meet the requirements of Specification D 2564.

7.9 *Joint Tightness*—Joints made with pipe and fittings or with belled-end pipe shall show no signs of leakage when tested in accordance with 8.9.

7.10—

7.2.6 *Extrusion Quality*—The pipe shall not flake or disintegrate when tested in accordance with 8.10.

7.3 *Requirements for Solvent Cemented Pipe and Fittings*

7.3.1 *Socket Diameter*—The inside diameter of the tapered socket shall comply with the dimensions listed in Table 4 when determined in accordance with 8.5.1.

7.3.2 *Socket Depth*—The socket depth shall not be less than that shown in Table 4 when measured in accordance with 8.5.2.

7.3.3 *Wall Thickness of Molded Fittings*—The wall thicknesses of the waterway and socket or bell of molded fittings shall be no less than the respective minimum thicknesses listed for the equivalent pipe in Table 1. For reducing fittings or those with smaller inlets, the minimum wall thickness of each inlet shall be no less than the minimum wall thickness for that size pipe. The thickness shall be determined in accordance with Test Method D 2122 and 8.5.3.

7.3.4 *Spigot Length*—The minimum distance from the spigot end to the area where the spigot diameter changes due to a socket, branch, or change in angle shall comply with the “C” dimension of Table 4.

7.4 *Fabricated Fittings*—Any fitting made from pipe or from a combination of pipe and molded parts shall be considered a fabricated fitting and the following provisions shall apply (see Table 5).

7.4.1 *Over-Wrapped Fittings*—Fabricated fittings that have an over-wrap of fiberglass reinforced thermosetting resin or other similar materials shall meet all of the requirements in 7.4.2 and 7.4.3.

NOTE 4—Refer to Appendix X3 for geometric configurations of some of the fittings being produced. Consult the individual manufacturer for laying lengths.

7.4.2 *Fabricated Fittings General Requirements:*

7.4.2.1 Pipe used in fabricated fittings shall meet all quality and dimensional requirements listed in the standard for that pipe.

7.4.2.2 Pipe used in fabricated fittings shall have a wall thickness equal to or greater than the wall thickness of the pipes to which the fitting (or that part of the fitting) will be joined.

7.4.2.3 No part of the spur or branch shall protrude into the waterway of the fitting more than 0.070 in.

7.4.2.4 All edges and joints exposed to sewage shall be rounded and free from any rough parts that could catch solids.

7.4.2.5 No fitting shall have an inside diameter dimension smaller than the base inside diameter listed in Table X1.1 for that pipe size and DR.

7.4.2.6 All welds and solvent cement joints shall be sound and free of visible defects.

7.4.3 *Fabricated Fittings Test Requirements:*

7.4.3.1 These requirements apply only to tee, wye, and bend fittings.

7.4.3.2 Deflect the fitting by applying the prescribed load to the body of the fitting (see Fig. 1 and Table 5). Apply the load over a 1 to 2-min period and maintain the load for 5 min. Inspect all welds and fabrication joints while the load is on the fitting. Any evidence of cracking or separation shall constitute failure of this requirement.

7.4.3.3 After completing the load test, plug all openings and pressure test at 25-ft head of water for 10 min. Any visible leakage of water at the fabrication joint or through the body constitutes failure to meet this requirement.

7.4.3.4 Fittings that have successfully passed both the load and pressure test are suitable for sale and use.

NOTE 5—Fitting Body Length: For bends use center line length. (Blocks shall be 2 in. shorter than body length.)

NOTE 6—This test is applicable to tees, wyes, and bends. Fittings shall be supported on a flat wood block, and the load shall be applied to a second block as shown. The TEST LOAD shall be computed by multiplying the F value in Table 5 by the length of the fitting body.

7.4.3.3 After completing the load test, plug all openings and pressure test at 25-ft head of water for 10 min. Any visible leakage of water at the fabrication joint or through the body constitutes failure to meet this requirement.

7.4.3.4 Fittings that have successfully passed both the load and pressure test are suitable for sale and use.

TABLE 4 MiSolvenit Cemum Pipe Stiffnt Sockess at 5 %
Dimefectnsions

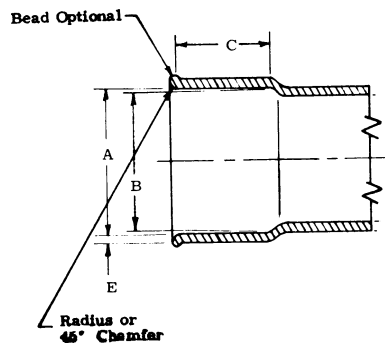
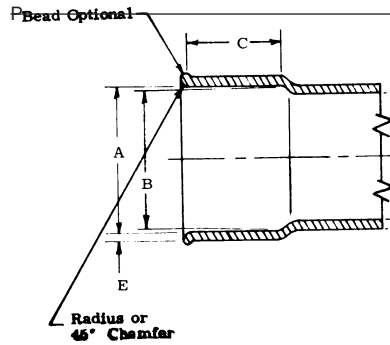

Nominal Size, in.	A	B	C
Nominal Size, in.	<u>A</u>	<u>B</u>	<u>C</u>
Pipe Stiffness, 205 ± 0.009 (psi)	—	4.210 ± 0.009	—1.75
4	4.235 ± 0.009	4.210 ± 0.009	1.75
SDR36	—	—SDR26	SDR23.5
6	6.305 ± 0.011	6.270 ± 0.011	3.5
000	8.424 ± 0.012	8.388 ± 0.012	4.000
4 (190(28))	—	320(46)	790(115)
6 to 15	—	320(46)	790 (0)
9	9.486 ± 0.014	9.426 ± 0.014	4.500
1055	—	15 ± 0.015	—5.000
1010.530 ± 0.015	—	10.485 ± 0.015	5.000
12.52	—	12.482 ± 0.018	—6.000
18	12.536 ± 0.018	12.482 ± 0.018	6.000
15 5(346 ± 0.023)	—	—153)	—
1515.346 ± 0.023	—	15.277 ± 0.023	7.500

NOTE 7—These test requirements have been selected to evaluate quality of fabrication. They are not intended to simulate service conditions or to require testing of every fitting.

7.5 Solvent Cement— The cement shall meet the requirements of Specification D 2564.

7.6 Requirements for Pipe and Fittings with Elastomeric Gasket Joints:

7.6.1 Pipe Requirements—In addition to the requirements of 7.2, the assembled joint shall display no leakage when tested in accordance with the requirements of Specification D 3212.

7.6.1.1 Bells—The dimensions shall be in accordance with the manufacturer’s standard design dimensions and tolerances.

7.6.2 Fitting Requirements—With the exception of spigot lengths, molded and fabricated fittings with elastomeric gasket joints shall comply with the requirements of Specification F 1336.

7.6.2.1 Spigot Length— The minimum distance from the spigot end to the area where the spigot diameter changes due to a socket, branch, or change in angle shall comply with the “ C ” dimension of Table 4.

8. Test Methods

8.1 Conditioning— Condition the test specimens at $23 \pm 2^\circ\text{C}$ ($73.4 \pm 3.6^\circ\text{F}$) and $50 \pm 5\%$ relative humidity for not less than

TABLE 5 Fabricated Fitting Loads—F^A

Fitting Body Pipe Size, in.	F (lb/in. of length)
4	13.3
4	13.3
6	20.0
6	20.0
8	26.7
8	26.7
9	30.0
10	33.3
12	40.0
15	50.0

^AF is the load required to produce 7.5 % deflection in SDR 35 (PS46) PVC pipe.

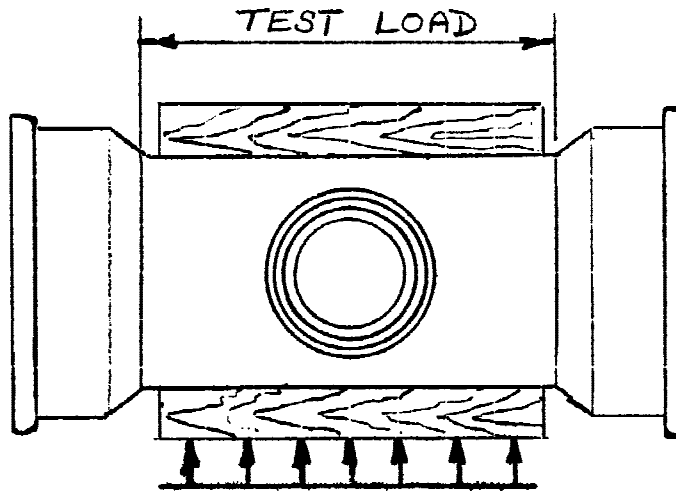

Fitting Body FIG. 1 Length: For blends use center line length. (Blocks shall be 2 in. shorter than body length.)

NOTE 2— This test is applicable to tees, wyes, and bends. Fittings shall be supported on a flat wood block, and the load shall be applied to a second block as shown. The TEST LOAD shall be computed by multiplying the PVC F-value in Table 5 by the length of the fitting body.

40 h prior to test in accordance with Procedure A of Practice D 618, for those tests where conditioning is required.

8.2 *Test Conditions*— Conduct tests in the standard laboratory atmosphere of $23 \pm 2^\circ\text{C}$ and $50 \pm 5\%$ relative humidity, unless otherwise specified in the test methods or in this specification.

8.3 *Sampling*—The selection of the sample or samples of pipe or fitting shall be as agreed upon by between the purchaser and the seller. In case of no prior agreement, any sample selected by the testing laboratory shall be deemed adequate.

8.4 *Pipe Dimensions:*

8.4.1 *Pipe Diameters*— Measure the average outside diameter of the pipe in accordance with the applicable section of Test Method D 2122. Either a tapered sleeve gage or a vernier circumferential wrap tape accurate to $\pm 0.02\text{ mm}$ ($\pm 0.001\text{ in.}$) may be used.

8.4.2 *Wall Thickness*— Measure the wall thickness in accordance with the applicable section of Test Method D 2122. Make sufficient readings, a minimum of six, to ensure that the minimum thickness has been determined. Use a cylindrical anvil tubing micrometer accurate to $\pm 0.02\text{ mm}$ ($\pm 0.001\text{ in.}$).

8.5 *Fittings Dimensions:*

8.5.1 *Socket Diameters*— Measure the inside diameters of the sockets at the entrance and bottom in accordance with the applicable section of Test Method D 2122. Calculate the average inside diameters at the entrance and the bottom of the socket by taking the mean of the minimum and maximum values.

8.5.2 *Socket Depth*— Measure the fitting socket depth using a steel rule with at least 1-mm ($1/16\text{-in.}$) graduations in accordance with the applicable section of Test Method D 2122.

8.5.3 *Wall Thickness*— Measure the wall thickness in accordance with the applicable section of Test Method D 2122. Make sufficient readings, a minimum of six, to ensure that the minimum thickness has been determined. Use a cylindrical anvil tubing micrometer accurate to $\pm 0.02\text{ mm}$ (0.001 in.).

8.6 *Pipe Flattening*— Flatten three specimens of pipe, 150- mm (6- in.) long, between parallel plates in a suitable press until the distance between the plates is 40 % of the outside diameter of the pipe. The rate of loading shall be uniform and such that the

compression is completed with 2 to 5 min. Remove the load and examine the specimens for evidence of splitting, cracking, or breaking.

8.7 *Impact Resistance*—Determine the impact resistance of the pipe in accordance with the applicable section of Test Method D 2444, using a 20-lb Tup A and the flat plate Holder B. Test six specimens each 150-mm (6 in.) long at the impact levels given in Table 3.2. All shall pass. If one fails, test another six specimens; 11 passes out of 12 tested shall be acceptable.

8.8 *Pipe Stiffness*—Determine the pipe stiffness at 5 % deflection using Test Method D 2412. Test three specimens each 150-mm (6 in.) long and determine the average pipe stiffness at 5 % deflection. The pipe stiffness shall equal or exceed the minimum value listed in Table 4.3.

NOTE 68—The 5 % deflection criterion, which was arbitrarily selected for testing convenience, should not be considered as a limitation with respect to in-use deflection. The engineer is responsible for establishing the acceptable deflection limit (Appendix X1).

8.9 *Joint Tightness*—Join two pieces of pipe by means of a fitting or socket in accordance with Practice D 2855 and using solvent cement as described in 7.85. Allow the joined unit to stand 24 h at room temperature. Subject the unit to an internal water pressure of 170 kPa (25 psi) at room temperature for 1 h, and examine the pipe, fitting, and joints for leakage.

8.10 *Extrusion Quality*—Tests shall be run in accordance with Test Method D 2152. This procedure is used for determining the extrusion quality of extruded PVC plastic pipe as indicated by reaction to immersion in anhydrous acetone. It is applicable only for distinguishing between unfused and properly fused PVC.

9. Inspection

9.1 Inspection of the material shall be made as agreed upon by the purchaser and the seller as part of the purchase contract.

10. Retest and Rejection

10.1 If the results of any test(s) do not meet the requirements of this specification, the test(s) shall be conducted again only by agreement between the purchaser and the seller. Under such agreement, minimum requirements shall not be lowered, changed, or modified, nor shall specification limits be changed. If, upon retest, failure occurs, the quantity of product represented by the test(s) does not meet the requirements of this specification.

11. Certification

11.1 When specified in the purchase order or contract, a manufacturer's certification shall be furnished to the purchaser that the material was manufactured, sampled, tested, and inspected in accordance with this specification, and has been found to meet the requirements. When specified in the purchase order or contract, a report of the test results shall be furnished. Each certification so furnished shall be signed by an authorized agent of the manufacturer.

12. Marking

12.1 Pipe in compliance with this specification shall be clearly marked as follows at intervals of 1.5 m (5 ft) or less:

12.1.1 Manufacturer's name or trademark and code,

12.1.2 Nominal pipe size,

12.1.3 The PVC cell classification, for example 12454,

12.1.4 The legend "SDR-41 PVC Sewer Pipe," "SDR-35 PVC Sewer Pipe," "SDR-26 PVC Sewer Pipe," or "SDR 23.5 PVC Sewer Pipe," and

12.1.5 This designation, "ASTM D 3034."

12.2 Fittings in compliance with this specification shall be clearly marked as follows:

12.2.1 Manufacturer's name or trademark,

12.2.2 Nominal size,

12.2.3 The material designation "PVC,"

12.2.4 This designation, "ASTM D 3034."

13. Quality Assurance

13.1 When the product is marked with this designation, D 3034, the manufacturer affirms that the product was manufactured, inspected, sampled, and tested in accordance with this specification and has been found to meet the requirements of this specification.

14. Keywords

14.1 fittings; PVC; sewer pipe

SUPPLEMENTARY REQUIREMENTS**GOVERNMENT/MILITARY PROCUREMENT**

These requirements apply *only* to federal/military procurement, not domestic sales or transfers.

S1. *Responsibility for Inspection*—Unless otherwise specified in the contract or purchase order, the producer is responsible for the performance of all inspection and test requirements specified herein. The producer may use his own or any other suitable facilities for the performance of the inspection and test requirements specified herein, unless the purchaser disapproves. The purchaser shall have the right to perform any of the inspections and tests set forth in this specification where such inspections are deemed necessary to ensure that material conforms to prescribed requirements.

NOTE S1.1—In U.S. federal contracts, the contractor is responsible for inspection.

S2. *Packaging and Marking for U.S. Government Procurement:*

S2.1 *Packaging*—Unless otherwise specified in the contract, the materials shall be packaged in accordance with the supplier's standard practice in a manner ensuring arrival at destination in satisfactory condition and which will be acceptable to the carrier at lowest rates. Containers and packing shall comply with Uniform Freight Classification rules or National Motor Freight Classification rules.

S2.2 *Marking*—Marking for shipment shall be in accordance with Fed. Std. No. 123 for civil agencies and MIL-STD-129 for military agencies.

NOTE S2.1—The inclusion of U.S. Government procurement requirements should not be construed as an indication that the U.S. Government uses or endorses the products described in this specification.

APPENDIXES**X1. BASE INSIDE DIAMETER FOR CALCULATION OF DEFLECTION LIMITS**

X1.1 Table X1.1 is provided to establish a uniform number representing the inside diameter to be used as a base for calculation of deflection limits. For the purpose of monitoring the quality of installation, a specifier may apply a deflection limit that he deems appropriate to the base inside diameter to arrive at a mandrel dimension for a go/no-go gage. For economy in fabrication of mandrels, it is suggested that the outside diameter of each mandrel be rounded to the nearest 0.01 in. or 0.2 mm for machining purposes. This procedure is demonstrated here for the 7½ % recommended limit of Appendix X2 (Example: $(100\% - 7.5\%) / 100 \times 5.800 = 5.37$).

X1.2 This base inside diameter is not a product quality control requirement, nor should it be used for flow calculations.

TABLE X1.1 Base Inside Diameters and 7½ % Deflection Mandrel Dimension

in.												
Nominal Size, in.	SDR-41			SDR-35			SDR-26			SDR 23.5		
	Average Inside Diameter	Base 7 1/2 % De	Average Inside Diameter	Base Inside Diameter	7 1/2 % De	Average Inside Diameter	Base Inside Diameter	7 1/2 % De	Average Inside Diameter	Base Inside Diameter	7 1/2 % De	
6	5.951	5.800	5.37	5.893	5.742	5.31	5.764	5.612	5.19	5.713	5.562	5.14
8	7.966	7.740	7.16	7.891	7.665	7.09	7.715	7.488	6.93
10	9.958	9.657	8.93	9.864	9.563	8.84	9.644	9.342	8.64
12	11.854	11.478	10.62	11.737	11.361	10.51	11.480	11.102	10.27
15	14.505	14.029	12.98	14.374	13.898	12.86	14.053	13.575	12.56

mm ^A												
6	151.16	147.32	136.3	149.68	145.85	134.9	146.41	142.54	131.8	145.11	141.27	130.6
8	202.34	196.60	181.8	200.43	194.69	180.1	195.96	190.20	175.9
10	252.93	245.29	226.9	250.54	242.90	224.7	244.96	237.29	219.5
12	301.09	291.54	269.7	298.12	288.57	266.9	291.59	281.99	260.9
15	368.43	356.34	329.6	365.10	353.01	326.5	356.95	344.80	318.9

^ABase inside diameter is a minimum pipe inside diameter derived by subtracting a statistical tolerance package from the pipe's average inside diameter. The tolerance package is defined as the square root of the sum of squared standard manufacturing tolerances.

$$\text{Average inside diameter} = \text{average outside diameter} - 2(1.06) t$$

$$\text{Tolerance package} = \sqrt{A^2 + 2 B^2 + C^2}$$

where:

t = minimum wall thickness (Table 1),

A = outside diameter tolerance (Table 1),

B = excess wall thickness tolerance = 0.06*t*, and

C = out-of-roundness tolerance.

The values for *C* were derived statistically from field measurement data and are given as follows for various sizes of pipe:

Nominal Size, in.	Value for <i>C</i>	
	in.	mm
6	0.150	3.81
8	0.225	5.72
10	0.260	6.60
12	0.260	6.60
15	0.300	7.62
18	0.300	7.62
24	0.375	9.52
30	0.375	9.52
36	0.475	12.06

X2. RECOMMENDED LIMIT FOR INSTALLED DEFLECTION⁵

X2.1 Design engineers, public agencies, and others who have the responsibility to establish specifications for maximum allowable limits for deflection of installed PVC sewer pipe have requested direction relative to such a limit.

X2.2 The PVC sewer piping made to this specification and installed in accordance with Practice D 2321 can be expected to

⁵ Supporting data can be obtained from ASTM Headquarters. Request RR:F-17-1009.

perform satisfactorily provided that the internal diameter of the barrel is not reduced by more than 7½ % of its base inside diameter when measured not less than 30 days following completion of installation.

X3. CONFIGURATIONS

X3.1 The following fittings, descriptions, and terms are commonly used in the plastic sewer piping industry (see Figs. X3.1–X3.9). However, these illustrations may not exhibit all the configurations produced. Therefore, consult the individual manufacturer as to sizes and laying length dimensions (see Symbols D 2749).

pick;fx00001;0;

pick;fx00002;0;

pick;fx00003;0;

pick;fx00004;0;

pick;fx00005;0;

pick;fx00006;0;

pick;fx00007;0;

pick;fx00008;0;

pick;fx00009;0;

ASTM International takes no position respecting the validity of any patent rights asserted in connection with any item mentioned in this standard. Users of this standard are expressly advised that determination of the validity of any such patent rights, and the risk of infringement of such rights, are entirely their own responsibility.

This standard is subject to revision at any time by the responsible technical committee and must be reviewed every five years and if not revised, either reapproved or withdrawn. Your comments are invited either for revision of this standard or for additional standards and should be addressed to ASTM International Headquarters. Your comments will receive careful consideration at a meeting of the responsible technical committee, which you may attend. If you feel that your comments have not received a fair hearing you should make your views known to the ASTM Committee on Standards, at the address shown below.

This standard is copyrighted by ASTM International, 100 Barr Harbor Drive, PO Box C700, West Conshohocken, PA 19428-2959, United States. Individual reprints (single or multiple copies) of this standard may be obtained by contacting ASTM at the above address or at 610-832-9585 (phone), 610-832-9555 (fax), or service@astm.org (e-mail); or through the ASTM website (www.astm.org).