



Standard Practice for Installation of Rigid Poly(Vinyl Chloride) (PVC) Siding and Soffit¹

This standard is issued under the fixed designation D 4756; the number immediately following the designation indicates the year of original adoption or, in the case of revision, the year of last revision. A number in parentheses indicates the year of last reapproval. A superscript epsilon (ϵ) indicates an editorial change since the last revision or reapproval.

1. Scope*

1.1 This practice covers the minimum requirements for and the methods of installation of rigid vinyl siding, soffits, and accessories on the exterior wall and soffit areas of buildings. In all applications, refer also to the specific manufacturer's instructions for installation.

1.2 This practice covers aspects of installation relating to effectiveness and durability in service.

1.3 The various application systems are located in the following sections of this practice:

Section 8	Substrate, Surface Preparation
Section 9	Application of Horizontal Siding
Section 10	Application of Vertical Siding
Section 11	Application of Soffits
Section 12	Special Details

1.4 The values stated in inch-pound units are to be regarded as the standard. The SI units given in parentheses are for information only.

NOTE 1—There are no ISO standards covering the subject matter of this practice.

1.5 *This standard does not purport to address all of the safety concerns, if any, associated with its use. It is the responsibility of the user of this standard to establish appropriate safety and health practices and determine the applicability of regulatory limitations prior to use.*

2. Referenced Documents

2.1 *ASTM Standards:*

¹ This practice is under the jurisdiction of ASTM Committee D20 on Plastics and is the direct responsibility of Subcommittee D20.24 on Plastic Building Products. Current edition approved ~~Nov. July~~ 10, 2002₃. Published ~~April August~~ 2003. Originally published in 1991. Last previous edition approved 2002, published as D 4745 – 02a.

D 883 Terminology Relating to Plastics²

D 1600 Terminology for Abbreviated Terms Relating to Plastics²

D 3679 Specification for Rigid Poly(Vinyl Chloride) (PVC) Siding³

D 4477 Specification for Rigid Poly(Vinyl Chloride) (PVC) Soffit³

E 631 Terminology of Building Constructions⁴

2.2 Council of American Building Officials:

CABO One and Two Family Dwelling Code: Section R-707 Attic Ventilation⁵

3. Terminology

3.1 *General*—Definitions are in accordance with Terminologies D 883 and E 631 and abbreviations with Terminology D 1600 unless otherwise indicated.

3.2 *Definitions of Terms Specific to This Standard:*

3.2.1 *backerboard*—a flat material used on the face of the house, applied between the studs and the siding (or over existing wall surface) to provide an even surface means install the vinyl siding.

3.2.2 *buttlock*—this is referred to as the bottom of a siding or soffit product, or accessory piece, opposite the nail hem, which locks onto the preceding panel.

3.2.3 *crimp*—small protrusions, typically approximately ½ in. (12.7 mm) long, ⅛ in. (3.2 mm) wide, and projecting ⅛ in. (3.2 mm) formed by a crimper (snaplock punch). (See Fig. 1.)

3.2.4 *crimper*—a special hand tool designed to form crimps (snaplock ears) intended to hold partial panels in place. (See Fig. 1.)

3.2.5 *face nail*—the action of fastening directly on to the “face” of a panel (instead of using the nail slot).

3.2.6 *fascia*—the trim along the perimeter of roofs or roof overhangs. (See Fig. 2.)

3.2.7 *flashing*—special membrane pieces or manufactured trim pieces used to supplement siding panels in weather protection around openings, such as windows and doors.

3.2.8 *furring/furring strip*—a wooden or steel framing material, usually a 1 × 2 in. used to even the surface in preparation of installation. To “fur” a surface means to apply these strips.)

3.2.9 *nailslot punch*—a special hand tool used to create slots for attachment of field-modified siding or accessories. (See Fig. 3.)

3.2.10 *snaplock ears*—See *crimp* and Fig. 1.

3.2.11 *snaplock punch*—See *crimper* and Fig. 1.

3.2.12 *soffit*—the underside surface (typically horizontal) of roof overhangs.

3.2.13 *Strapping*—Flexible materials (i.e. metal strips or hurricane ties used to provide shear or wind resistance.

3.2.14 *zip tool*—a special hand tool used to separate interlocked siding panels. (See Fig. 4.)

² Annual Book of ASTM Standards, Vol 08.01.

³ Annual Book of ASTM Standards, Vol 08.04.

⁴ Annual Book of ASTM Standards, Vol 04.07.

⁵ Available from Council of American Building Officials, 5203 Leesburg Pike, Falls Church, VA 22041.

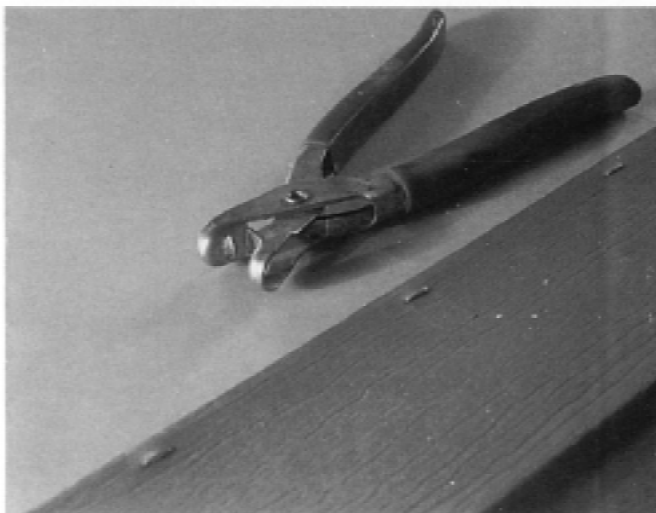

FIG. 1 Crimper and Crimps on Siding

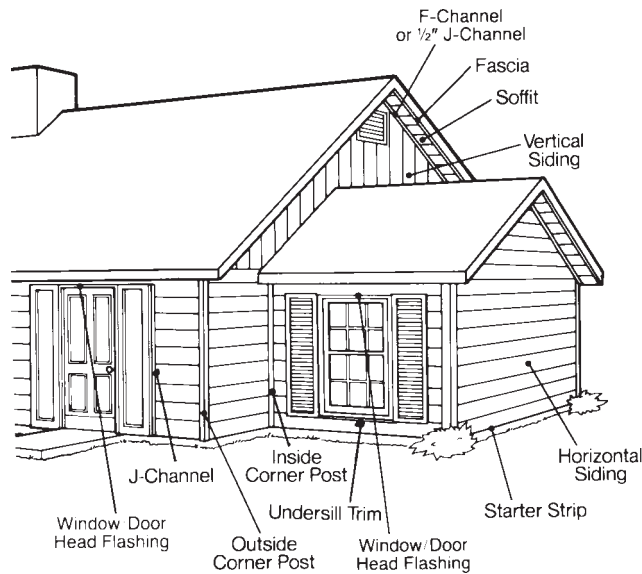

FIG. 2 Panels and Accessories

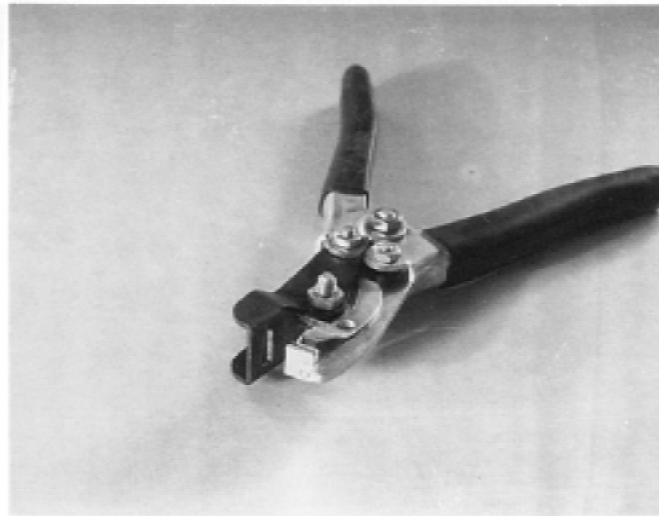

FIG. 3 Nailslot Punch

4. Delivery of Materials

4.1 All manufactured materials shall be delivered in the original packages, containers, or bundles bearing the size or type product, or both, brand name, and manufacturer (or supplier) identification, manufacturer's lot number, and the ASTM specification to which it conforms.

5. Protection of Materials

5.1 Vinyl siding and accessories will expand when heated and contract when cooled. If siding is installed in hot weather and the siding is very warm it will be partially "expanded" and allowance for more future "contraction" than expansion should be provided.

5.2 Do not store the crates or cartons in any location or in any manner where the temperature of the siding, soffit or accessories may exceed 130°F. (For example, on blacktop pavement during unusually hot weather or under dark tarps or plastic wraps without air circulation.) 130°F (54°C).

6. Environmental Conditions

6.1 Vinyl siding and accessories will expand when heated and contract when cooled. If siding is installed in hot weather and the siding is very warm it will be partially "expanded" and allowance for more future "contraction" than expansion should be provided.

6.2 If installing during weather colder than temperatures below 40°F, increase the minimum clearance to 3/8 in. at all openings

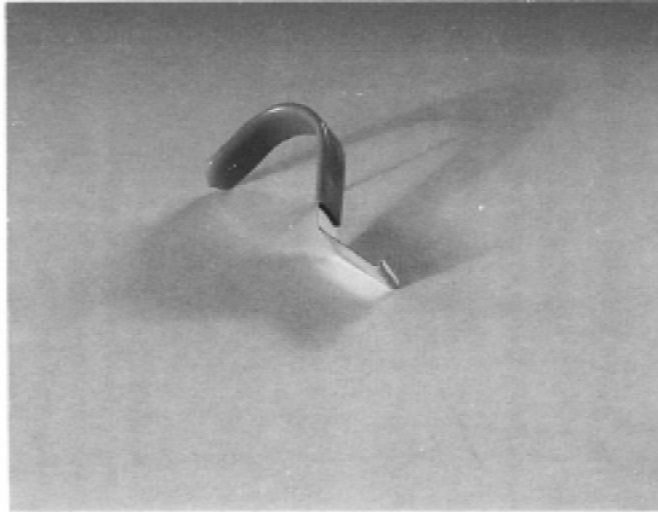

FIG. 4 Zip Tool

and stops to allow for normal expansion and contraction.

7. Materials

7.1 *Horizontal Wall Siding*—See Specification D 3679.

7.2 *Vertical Wall Siding*—See Specification D 3679

7.3 *Soffit Panels*—See Specification D 4477.

7.4 *Accessories:*

7.4.1 *Starter Strip*—Of two types: for horizontal siding and for vertical siding of poly(vinyl chloride) or noncorrosive metal.

7.4.2 *Corner Posts*—Of two types: for inside corners and for outside corners of poly(vinyl chloride).

7.4.3 *Trim Channels*—Produced of poly(vinyl chloride) in a variety of designs and sizes for use around openings and edges of wall and soffit surfaces. (See Fig. 5.)

7.4.4 *Fascia Panels*—Produced of poly(vinyl chloride), typically in a “J” shape with an extended flat leg, intended for field cutting to cover roof trim.

NOTE 2—To minimize the possibility of any color variation use material from a single manufacturer’s lot number for application to one building.

7.5 *Fasteners:*

7.5.1 *Nails*—Corrosion-resistant with head diameter $\frac{5}{16}$ in. (7.9 mm) minimum, shank diameter $\frac{1}{8}$ in. (3.2 mm), length sufficient to penetrate not less than $\frac{3}{4}$ in. (19 mm) into framing or furring.

7.5.2 *Staples*—Corrosion-resistant, 16 gage minimum, with $\frac{3}{8}$ to $\frac{1}{2}$ -in. (9.5 to 12.7-mm) crown, length sufficient to penetrate not less than $\frac{3}{4}$ in. (19 mm) into framing or furring.

7.5.3 *Screws*—Corrosion resistant, self-tapping type, No. 8 truss head or pan head length sufficient to penetrate wall thickness of steel stud or $\frac{3}{4}$ in. into framing or furring.

8. Substrate, Surface Preparation

8.1 Apply vinyl siding directly over sheathing or other solid surface that is in an even plane. Apply over wood furring strips when the surface is uneven.

8.1.1 Drive fasteners into framing, furring, or nailable sheathing or siding.

8.2 On existing structures, secure any loose boards, replace any rotted ones, recaulk around windows, doors, and other areas as necessary to protect from moisture penetration. Use furring as needed to create an even surface.

8.3 *Furring*—masonry and uneven surfaces, as examples, require wood furring strips nominal 1 by 2 in. (25.4 by 50.8 mm) applied vertically and typically spaced 16 in. (406 mm) on center for horizontal siding and applied horizontally and typically spaced 12 in. (305 mm) on center for vertical siding.

9. Application of Horizontal Siding

9.1 *General Requirements*—Vinyl siding and accessories expand and contract as much as $\frac{1}{2}$ " (12.7mm) over 12-ft (3.65m) length with changes in temperature. For this reason adhere to the following provisions:

9.1.1 When applied, vinyl siding products must be attached “loosely,” leaving approximately a $\frac{1}{32}$ -in. (0.8-mm) space between the vinyl and the fastener head or crown to permit thermal movement. (See Fig. 6.)

9.1.2 Center fasteners in slots of siding and accessories to permit possible expansion and contraction. (See Fig. 7.)

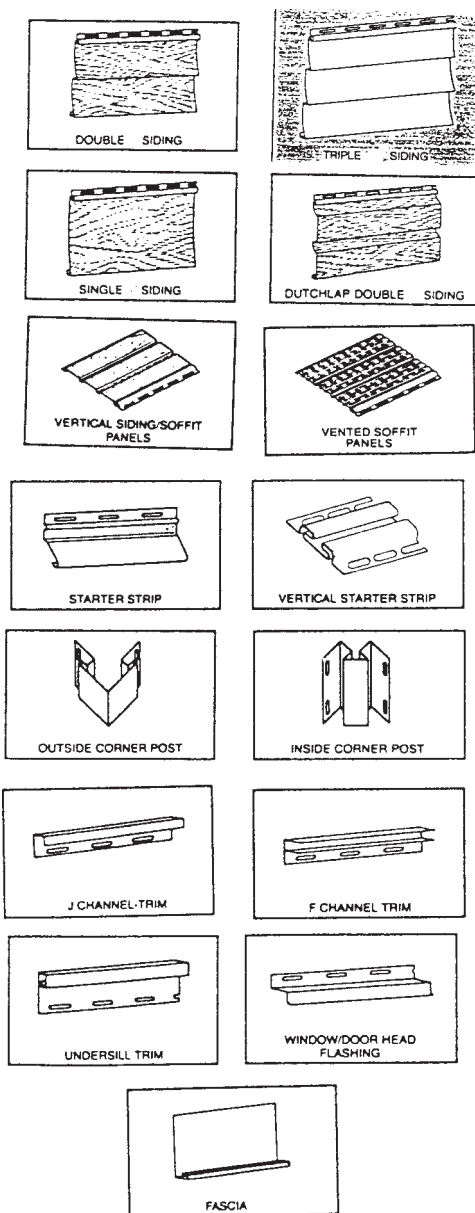

FIG. 5 Typical Trim Products

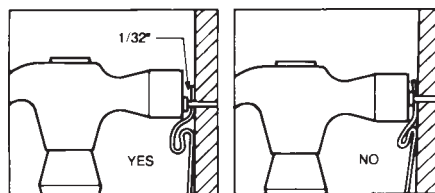

FIG. 6 Attachment of Vinyl Siding

9.1.3 Do not face nail; it would restrict any thermal movement. (See Fig. 8.)

9.2 *Installation of Accessories*—Accessories, including starter strips, corner posts and door/window trim, are installed prior to application of the siding adhering to the provisions of 9.1 and those which follow.

9.2.1 *Starter Strip*—Determine the lowest point along the area to receive siding and install starter strips located so that the bottom edge of the initial course of siding will be on a level line and typically approximately ¼ in. (6.4 mm) below that point. Allow space for corner posts, J-channels, etc., and keep ends of starter strips ¼ to ½ in. (6.4 to 12.7 mm) apart. Space fasteners not more than 10 in. (259 mm) apart, centered in nail slots.

9.2.2 *Corner Posts*—Outside and inside corner posts will start ¼ in. (6.4 mm) below the top, and end ¾ in. (19.1 mm) below

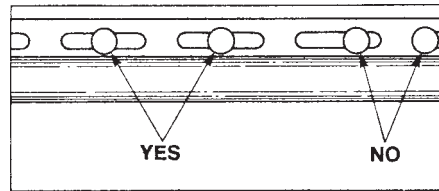

FIG. 7 Fastening Location in Siding Slots

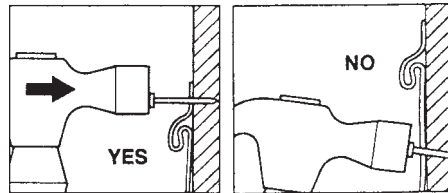

FIG. 8 Face Nailing of Vinyl Siding Prohibited

the bottom edge of the first course of siding which will be installed later. Attach each leg of the corner posts with fasteners, spaced not over 12 in (305 mm) apart centered in nailing slots except the top fastener that is located at the upper end of a nailing slot.

NOTE 3—If more than one length of corner post is required, lap the upper piece over the lower piece by cutting away 1 in. (25.4 mm) of the nailing flange on the top piece. Lap $\frac{3}{4}$ in. (19 mm) allowing $\frac{1}{4}$ in. (6.4 mm) for expansion. (See Fig. 9.)

NOTE 4—At inside corners, as an alternative, two J-channels may be installed with the web of one abutting the adjacent wall and the web of the other J-channel abutting the shorter outer flange of the first J-channel. Attach as specified in 9.1.1.

9.2.3 Door/Window Trim:

9.2.3.1 Install J-channel on each side of door and window frames extending from the top of the frames to the bottom of the sill for doors and extending below for windows the depth of the short exposed leg of undersill trim (typically $\frac{7}{8}$ in. (22 mm)) that will be installed below window sills. Notch the lower end ($\frac{7}{8}$ in. excess) to later accept the siding panel under the window. (See Fig. 10.)

9.2.3.2 Across the top install head flashing (optional) and J-channel that extends to the outer edges of the exposed legs of the side J-channels. Cut out each end of the head flashing to match the contour of the side J-channels and fasten in place. Cut along the bends of the J-channel in $\frac{3}{4}$ in. (19 mm) from each end, bend down the resultant tabs of the web, insert them into the side J-channels and fasten in place as shown in Fig. 11.

9.3 Siding Panel Installation:

9.3.1 *General Considerations*—To make overlapped siding joints less noticeable on the sides of a building, start at the rear corner and install toward the front. On the front and rear of buildings start at the corners and install toward the entrance door. Avoid use of short panel lengths under 24 in. (610 mm). When lapping, factory-cut ends of panels should be on top of field-cut ends for best appearance.

9.3.2 Engage the bottom of the first panel and the starter strip. If backerboard insulation is used, drop it in behind the panel now. Make sure the panel is locked, but not pulled tight, and fasten leaving $\frac{1}{4}$ in. (6.4 mm) gap at the corner posts. Space fasteners not over 16 in. (406 mm) on center. (See Fig. 12.)

9.3.3 Lap the next panel over the first by one-half of the factory cut notch. (See Fig. 13.) Insert backerboard (if used) and fasten.

9.3.4 To field-notch a panel where the factory notch has been cut off, cut away $1\frac{1}{2}$ in. (38 mm) of the nailing flange and lock. Cut a $\frac{1}{8}$ by $1\frac{1}{2}$ -in. (3.2 by 38-mm) notch from the bottom step of the panel, cutting away the hook on the back as well. (Field cut notches should be identical to factory notches.)

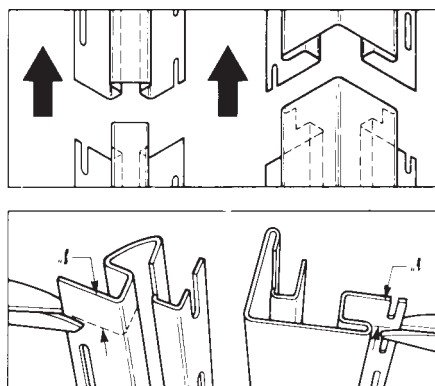

FIG. 9 Joining Corner Posts

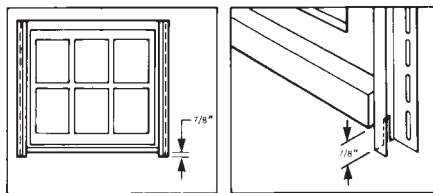

FIG. 10 Installation of Window and Door Trim

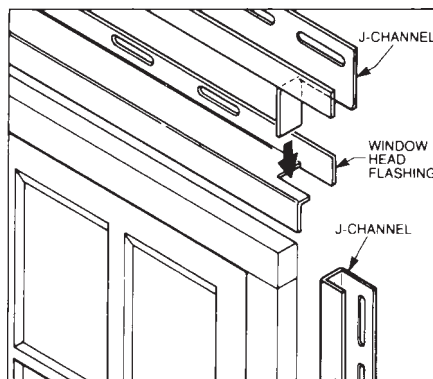

FIG. 11 Installation of Door and Window Trim

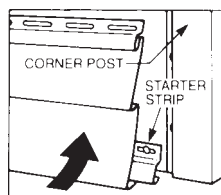

FIG. 12 Fastening of Initial Siding Panel

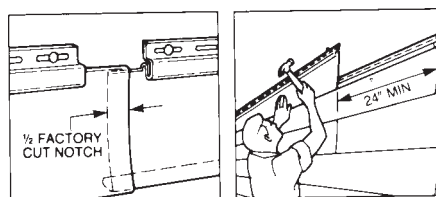

FIG. 13 Lapping Siding Panel

9.3.5 At the bottom of the window, snugly install between the side J-channels and against the underside of the sill, a piece of undersill trim cut to the exact width of the window. Use the proper thickness of furring behind it to keep the pitch of the panel consistent. Flash or caulk the J-channel –undersill intersections to prevent water infiltration. (See Fig. 14.)

9.3.6 At a window a siding panel may have to be cut to fit under the opening. Be sure this panel extends on both sides of the window. Measure the panel to fit. Hold the siding panel under the window and mark the width of the opening on it. Allow 1/4 in. (6.4 mm) clearance at the edges for insertion into each side of the J-channel. Measure the space between the bottom edge of the S-lock on the previous panel and the top of the undersill trim, minus 1/4 in (6.4 mm) for insertion into the undersill trim receiver. Remove cut section. Punch snap locks every 6 in. (152 mm) along the horizontal cut edge. Slide the panel up into position so the bottom locks into the previous panel and the top snaps into the undersill trim and fasten. (See Fig. 15.)

9.3.7 Over a window or door, measure for the cuts. Mark the bottom portion of the panel and cut out the unwanted section. Install the panel. (See Fig. 16.)

NOTE 5—In some instances it may be necessary to place a piece of furring into the J-channel behind the cut edge of the siding to reduce wind movement and maintain the proper plane of this siding. Leave enough gap at the top of the cutout so you can lock onto the previous course.

9.3.8 At a gable, install J-channel along the rake boards. (See Fig. 17.) Lap the channels if necessary by cutting 1 in. (25.4 mm) off the end leaving only the face and then lap 3/4 in. (19 mm). Miter the ends that meet at the peak to make a neat joint. (See Note 5.) Lock each pre-cut siding panel into the siding panel below and slide it into J-channel allowing 1/4-in. (6.4-mm) expansion gap between the end of the siding and back of the J-channel. The panel for the top of the gable may be face nailed. Drill a hole the

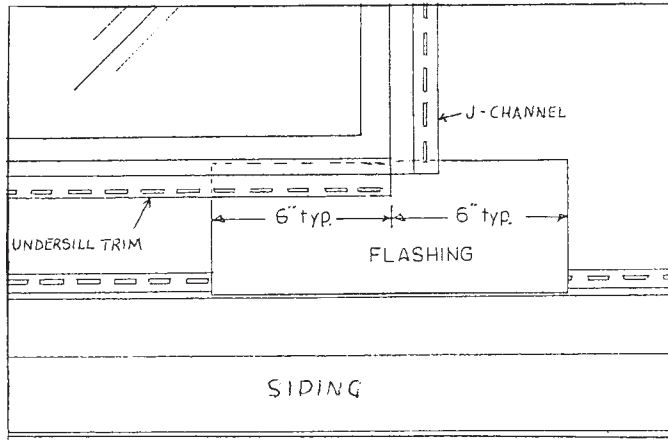

FIG. 14 Installation of Window Undersill Trim

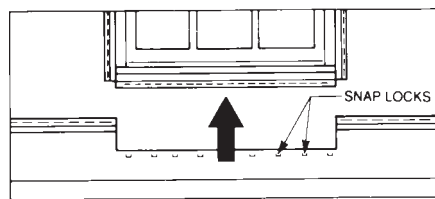

FIG. 15 Preparation of Siding Panel Under Window

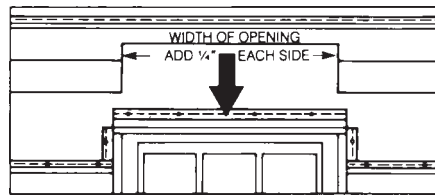

FIG. 16 Installation Over Window or Door

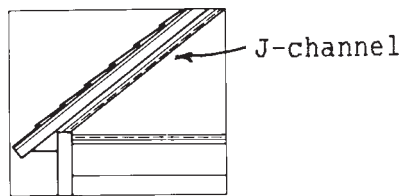

FIG. 17 Installation on Gable

size of the nail shank in the center of this triangular panel. Lock the panel in place and drive one nail into the pre-drilled hole. Do not nail it tight! Nailing into the panel without a pre-drilled hole may crack or kink the vinyl. (See Fig. 18.)

NOTE 6—A pattern can be made from two pieces of scrap siding. (See Fig. 19(a).) Hold one piece on the lock of the last installed panel, place the other piece against the gable and mark the horizontal piece. Cut along the mark and use this piece as a pattern for the remaining siding panels on that side. (See Fig. 19(b).) Make another pattern for the other end of the panels.

9.3.9 The final panel under an eave is handled like the portion under a window. Nail undersill trim to the top of the sidewall (see Fig. 20), flush with the underside of the eave. If more than one length of undersill trim is needed, splice as shown in Fig. 21.

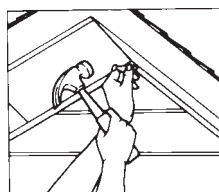
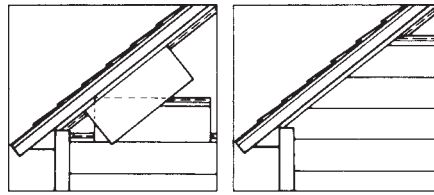

FIG. 18 Nailing of Panel at Top of Gable



(a) Pattern

(b) Use

FIG. 19 Gable

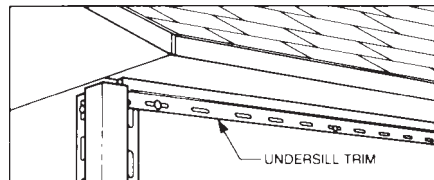

FIG. 20 Undersill Trim at Top of Sidewall

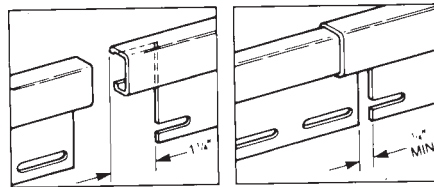

FIG. 21 Undersill Trim Splice

To determine the amount of the top panel to be cut off, measure from the bottom of the undersill trim lock to the bottom of the preceding panel lock minus $\frac{1}{4}$ in. (6.4 mm). (See Fig. 22.) Cut the panels accordingly. Punch snap-locks every 6 in. (152 mm) along the cut edge and slide it up into position. (See Fig. 22.)

10. Application of Vertical Siding

10.1 For general requirements see 9.1 and 9.2.

10.2 *Head Flashing*—Determine the lowest point along the area to receive siding and install J-channels or head flashing located so that the lower edge of the nailing flange will be on a level line with that point all along the area to receive siding. Leave $\frac{1}{4}$ in. (6.4 mm) gap at all corner posts and J-channels. To lap two pieces cut away 1 in. (25.4 mm) of the nailing flange of the overlapping piece and lap $\frac{1}{2}$ in. (12.7 mm). (See Fig. 23.)

10.3 *Top of Sidewalls*—If vinyl soffits are to be installed they should be installed before installation of J-channels at the top of all sidewalls. For vinyl soffit installation see Section 11. Install J-channels along the top of all wall areas that will receive vertical siding. Lap where necessary, removing 1 in. (25.4 mm) of the nailing flange of the overlapping piece and lap $\frac{1}{2}$ in. (12.7 mm). (See Fig. 24.)

10.4 Trim around all windows and doors

10.4.1 Cut a $\frac{1}{2}$ -in. (12.7-mm) J-channel for the bottom of the window as wide as the frame and install it.

10.4.2 Cut side J-channels the length of the frame plus the width of the face of the bottom J-channel. Cut and bend tabs into the bottom channel. Install the side channels. (See Fig. 25(a).)

10.4.3 Cut the top J-channel, and head flashing (use is optional) the width of the frame plus the width of the face of the side J-channels. Cut out the ends of the head flashing to match the side channels and install it. Notch the top J-channel on each end, bend the tabs into the side channels, and attach the top channel. (See Fig. 25(b).)

10.5 *Vertical Starter Strip*—Locate the center of each sidewall, vertically align the starter strip at the center using a level or plumb line. Leave a $\frac{1}{4}$ -in. (6.4-mm) gap at the top and bottom. Attach each leg of the vertical starter strip placing the top fastener at the upper end of a nailing slot and with the remaining fasteners spaced not over 12 in. (305 mm) apart centered in nailing slots. (See Fig. 26.)

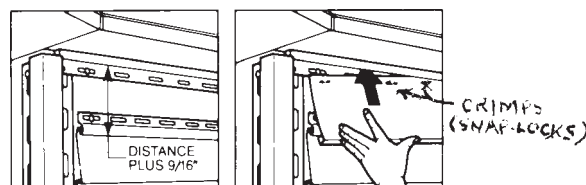

FIG. 22 Preparation and Installation of Final Pattern

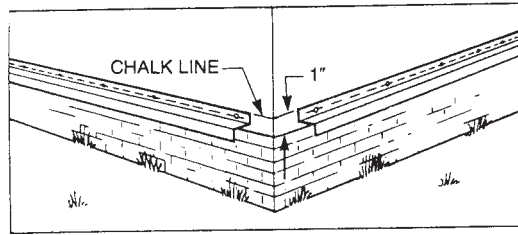

FIG. 23 Installation of Head Flashing

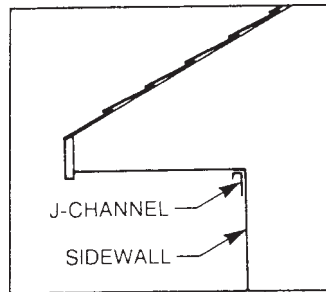
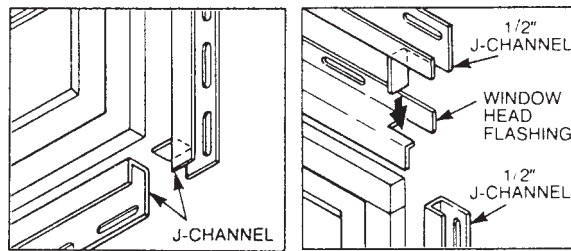

FIG. 24 J-Channel Installation at Top of Sidewall



(a) Window (b) Door

FIG. 25 Trim Assembly

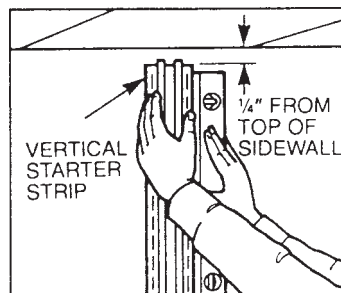

FIG. 26 Vertical Starter Strip Installation

10.6 Install vertical siding working from the starter strip to the corners with fasteners located as specified in 10.5. Leave a 1/4-in. (6.4-mm) space at the top and bottom to allow for expansion.

10.7 For application of vertical siding to gables, begin by nailing the vertical starter strip so that it will be centered with the peak of the gable. Make a pattern for end-cuts along the gables using two pieces of scrap siding. Lock one piece on the starter strip just under the eave. Hold the edge of the other piece against, and in line with, the roof line. Mark and cut the vertical piece. Use it as a pattern to mark and cut the ends of all other panels required for this side of the gable end. Make another pattern for the other side of the gable. (See Fig. 27.)

NOTE 7—If it will take more than one course to span the height of the house, terminate the first course into inverted J-channel allowing 1/4 in. (6.4 mm) for expansion. Install head flashing (if used) on top of the J-channel and begin the second course leaving 1/4 in. (6.4 mm) gap at the head flashing. (See Fig. 28.)

10.8 At windows and doors, cut the panels to fit the opening allowing 1/4 in. (6.4 mm) for expansion.

10.8.1 If the panel is cut down in the V-groove, fasten a wood furring stop as shown in Fig. 29, with fasteners that do not

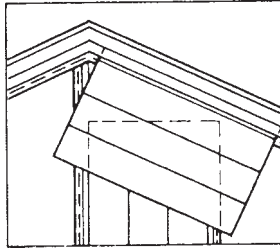

FIG. 27 Pattern Preparation for Gable End-Cuts

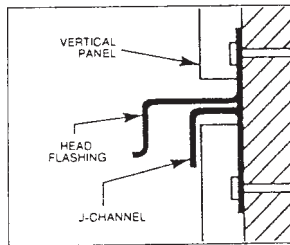

FIG. 28 Joining Area-Multicourse Installation

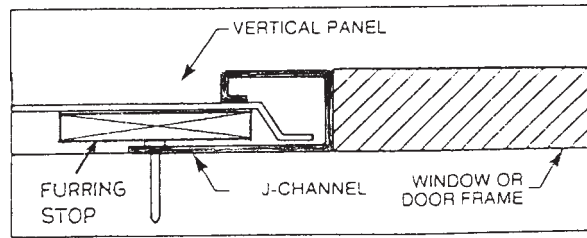

FIG. 29 Fastening of Wood Furring Stop

penetrate the legs of the J-channel or corner post, insert the cut side over the furring stop and into the J-channel, locking the other side into the last panel. (See Fig. 29.)

10.8.2 If the panel is cut on the flat surface, install undersill trim, or a $\frac{7}{16}$ -in. (11.1-mm) thick furring strip, into the J-channel using fasteners that do not penetrate the leg of the J-channel. Punch snap locks along the edge of the panel at 6-in. (152-mm) intervals, snap it into the space below the return of the J-channel, locking the other side into the last panel. (See Fig. 30.)

10.9 At corners, insert $\frac{1}{2}$ -in. (12.7-mm) J-channel into the receiver of the corner post.

10.9.1 If panel is cut in the bottom of the V-groove, insert into the J-channel. A furring stop should be provided prior to panel insertion. This will prevent the panel from detaching. (See Fig. 31.)

10.9.2 If the panel is cut on the flat surface, place a piece of undersill trim, backed by furring, into the receiver of the corner post. Punch snap locks along the cut edge of the panel at 6-in. (152-mm) intervals and snap it into the undersill trim. (See Fig. 32.)

NOTE 8—Furring may be positioned farther into the corner post than illustrated, however, nails (fasteners) used to attach the furring and undersill trim shall not penetrate the fastening leg of the outside corner post. In addition, the furring should not be positioned too far into the outside corner post where it will restrict the channeling of runoff water.

11. Application of Soffits and Fascia (See Fig. 33.)

11.1 Requirements for Proper Ventilation :

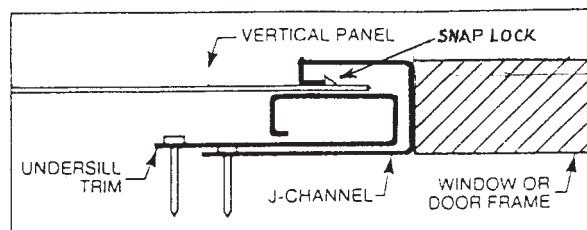

FIG. 30 Installation With Panel Cut on Flat Surface

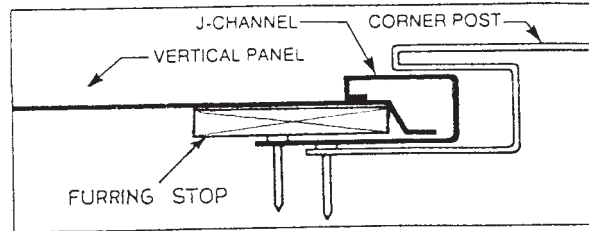

FIG. 31 Installation of Panel Cut-in Bottom of V-Groove

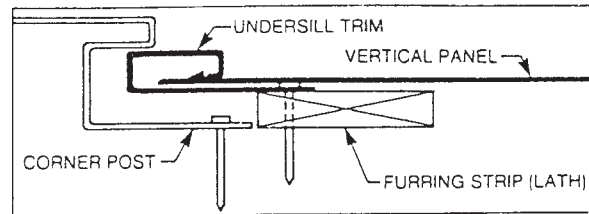

FIG. 32 Snapping Panel Cut on Flat Surface into Undersill Trim

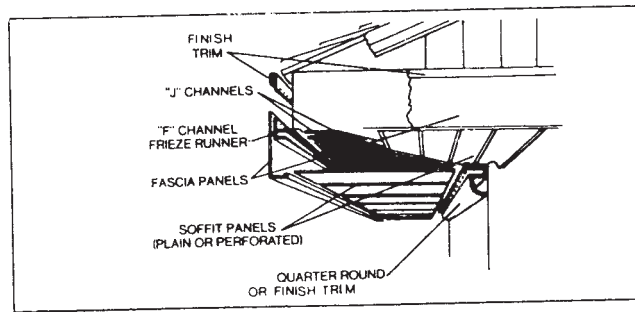

FIG. 33 Application of Soffit and Fascia

11.1.1 Calculation of perforated soffit needed for ventilation.

11.1.1.1 Proper attic ventilation is important for any home or dwelling. Consult a local building official for the appropriate requirements for a specific geographical area, and use vented soffit or other vented products as necessary.

11.2 Installation of Soffit on an Open Rafter (See Fig. 34):

11.2.1 Provide two parallel slots to hold and support the soffit panels.

11.2.1.1 Fasten an F-channel directly to wall at 6 to 12-in. (152 to 305-mm) intervals. Center the fasteners in the nail slot.

11.2.1.2 Fasten an F-channel on the outer bottom edge of the fascia board.

11.2.2 Cut a soffit panel to fit into the slots of the F-channels. Allow 1/4 in. (6.4 mm) per side for expansion.

11.2.3 Slide the soffit panels into the F-channel slots. Panels are hooked together. On panel sections over 24 in. (610 mm) wide, intermediate nailing supports are required.

11.2.4 Where two soffit surfaces meet, a T-channel or two 1/2-in. (12.7-mm) J-channels properly supported and nailed back-to-back will provide support for the soffit panel.

11.2.5 At the ends, pieces of F-channel or 1/2-in. (12.7-mm) J-channel, are installed to finish the job.

11.3 Installation of Soffit on an Enclosed Rafter (See Fig. 35.):

11.3.1 Provide two parallel slots to hold and support the soffit panels.

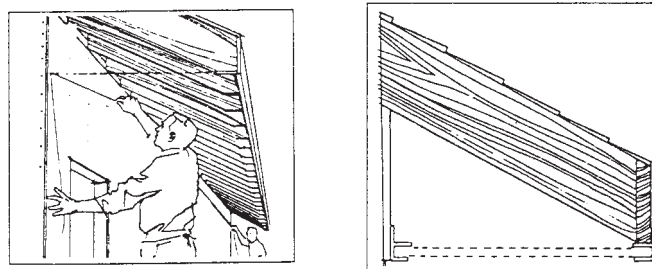
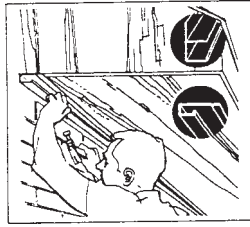

FIG. 34 Installation of Soffit on Open Rafter



NOTE 1—Apply the vinyl components over the existing unit.
FIG. 35 Installation of Soffit on Enclosed Rafter

- 11.3.1.1 Fasten an F-channel to the outer bottom edge of the fascia board.
- 11.3.1.2 Nail a quarter round Frieze moulding or a J-channel to the wooden soffit or an F-channel to the wall so that the slot to hold the soffit is parallel to the slot in the F-channel on the fascia board.
- 11.3.2 Cut a soffit panel to fit into the slots of the F-channels. Allow ¼ in. (6.4 mm) per side for expansion.
- 11.3.3 Slide the soffit panels into the F-channel slots. Panels are hooked together.
- 11.3.4 At the ends, pieces of F-channel or ½-in. (12.7-mm) J-channel are installed to finish the job.

11.4 *Installation of Fascia:*

- 11.4.1 Install undersill trim molding at the top of the fascia boards. (See Fig. 36.)
- 11.4.2 Measure the cover required and cut the fascia cover to proper width. Punch snaplock “ears” every 6 to 12 in. (152 to 305 mm) along the top of the fascia using a snaplock punch. (See Fig. 37.) Position the panel and secure the bottom lip of the fascia over the F-channel or J-channel, (See Fig. 38.), and snap into the undersill trim.

11.5 *Installation of Corner Cap :*

- 11.5.1 Trim the fascia cover ends at the corners as in Fig. 39.
- 11.5.2 A corner cap can be prefabricated or fashioned from a piece of fascia cover. Cut a 5½-in. (140-mm) length of fascia cover and mark a vertical centerline on the back as shown in Fig. 40. Cut out a 90° section of bottom flange from the center, leaving 45° on each side. Using a hand seamer, fold along the centerline to form a right angle.
- 11.5.3 Punch the top edge of a corner cap with a snaplock punch. Hook the bottom ends of the cap over the fascia flange and push the top into the undersill trim slot to lock into place. (See Fig. 41.)

12. Special Details

12.1 *Fitting Siding Around Faucets or Railing:*

- 12.1.1 Always begin a course of siding at an obstruction such as a faucet or wrought iron railing to avoid excess lap joints.
- 12.1.2 Cut a slot ¼ in. (6.4 mm) bigger than the obstruction, matching the contour of the obstruction. Install the first piece of siding as shown in Fig. 42(a).
- 12.1.3 Match the contour of the obstruction in the end of the next panel and lap it over the first one. (See Fig. 42(b).)
- 12.1.4 Apply flexible caulk around the obstruction to seal the penetration, but do not caulk the siding overlap.

NOTE 9—All caulking to prevent moisture penetration must be done before siding application. Caulk should never be used where it could restrict the normal expansion of the vinyl siding.

12.2 *Installing Siding Around Electric Boxes*—J-channel can be placed around the service box, meter, or outlet cover in the same manner as for windows (see 9.2.3).

12.3 *Shutter Installation:*

- 12.3.1 Pre-drill holes through the shutters for attachment screws and mark their location on the siding. (See Fig. 43.)
- 12.3.2 Drill ¾-in. (19-mm) expansion holes through the siding (siding only) where attachment screws will be located. (See Fig. 43.)
- 12.3.3 When attaching the shutters do not fasten such that the shutter bears tightly against the siding otherwise expansion of the siding will be restricted. (See Fig. 43.)

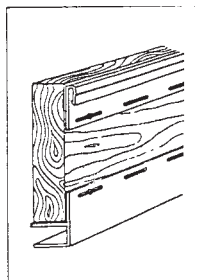

FIG. 36 Installation of Undersill Trim

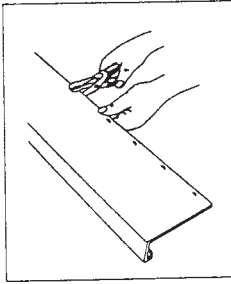

FIG. 37 Punch Snaplock Ears on Fascia

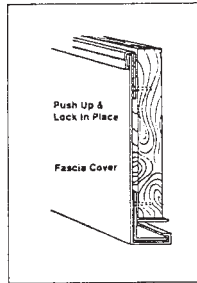

FIG. 38 Positioning of Fascia

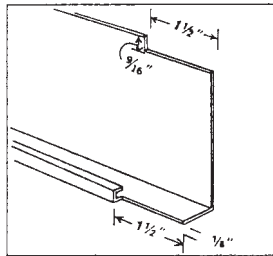

FIG. 39 Trimming Fascia Corner Ends

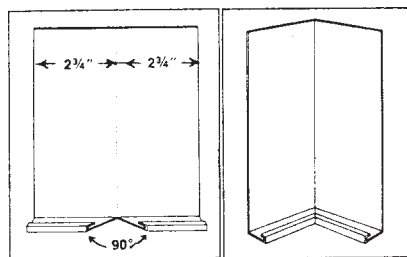

FIG. 40 Prefabricating Corner Cap

13. Keywords

13.1 crimp; horizontal siding; installation practice; poly(vinyl chloride) (PVC); vertical siding; vinyl siding; vinyl soffits

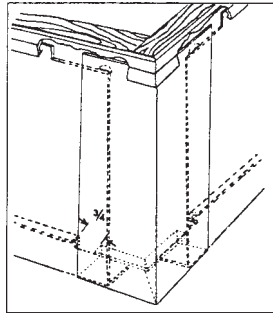
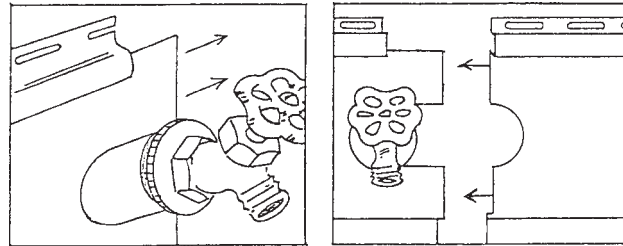

FIG. 41 Installation of Corner Cap



(a) Around Faucets

(b) Around Railings

FIG. 42 Fitting Siding

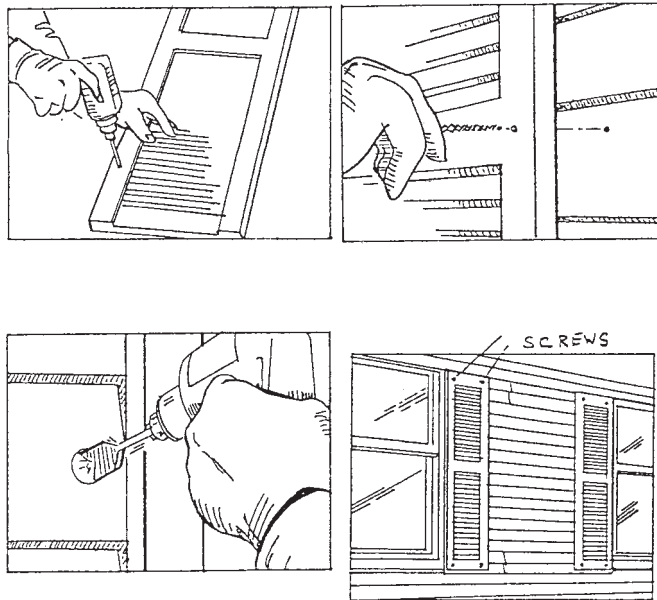

FIG. 43 Shelter Installation

SUMMARY OF CHANGES

Committee D20 has identified the location of selected changes to this standard since the last issue D 4756-02a that may impact the use of this standard. (Approved Nov. 10, 2002)

(1) Reworded section 5.2.

Committee D20 has identified the location of selected changes to this standard since the last issue D 4756-02 that may impact the use of this standard. (Approved April. 10, 2002)

- (1) Added terminology to Section 3, “Terminology”
- (2) Added outside storage information in 5.5.2
- (3) Reword 5.1.
- (4) Added allowance of $\frac{3}{8}$ in. expansion and contraction while installing in below 40°F temperatures in 6.2
- (5) Added 7.5.3 *Screws* to 7.5 *Fasteners*
- (6) Changed Furring strips to 1 by 2 in. in 7.3 *Furring*
- (7) Changes to Section 9:
 - 9.2.1 Starter Strip: $\frac{1}{4}$ in. below lowest point substrate
 - 9.3.6 Finishing under windows, new measuring points
 - 9.3.9 Finishing under eaves, new measuring points.
- (8) Changes to Section 11:
 - 11.1.1.1 through 11.1.2 Requirements for Proper Ventilation: states to consult local officials for those details.
 - 11.2.2 Cutting soffit for open rafter: allow $\frac{1}{4}$ in. per side for expansion.
 - 11.3.2 Cutting soffit for closed rafter: allow $\frac{1}{4}$ in. per side for expansion.

ASTM International takes no position respecting the validity of any patent rights asserted in connection with any item mentioned in this standard. Users of this standard are expressly advised that determination of the validity of any such patent rights, and the risk of infringement of such rights, are entirely their own responsibility.

This standard is subject to revision at any time by the responsible technical committee and must be reviewed every five years and if not revised, either reapproved or withdrawn. Your comments are invited either for revision of this standard or for additional standards and should be addressed to ASTM International Headquarters. Your comments will receive careful consideration at a meeting of the responsible technical committee, which you may attend. If you feel that your comments have not received a fair hearing you should make your views known to the ASTM Committee on Standards, at the address shown below.

This standard is copyrighted by ASTM International, 100 Barr Harbor Drive, PO Box C700, West Conshohocken, PA 19428-2959, United States. Individual reprints (single or multiple copies) of this standard may be obtained by contacting ASTM at the above address or at 610-832-9585 (phone), 610-832-9555 (fax), or service@astm.org (e-mail); or through the ASTM website (www.astm.org).