



Standard Specification for Metal Insert Fittings Utilizing a Copper Crimp Ring for SDR9 Cross-linked Polyethylene (PEX) Tubing¹

This standard is issued under the fixed designation F 1807; the number immediately following the designation indicates the year of original adoption or, in the case of revision, the year of last revision. A number in parentheses indicates the year of last reapproval. A superscript epsilon (ϵ) indicates an editorial change since the last revision or reapproval.

1. Scope

1.1 This specification covers metal insert fittings and copper crimp rings for use with cross-linked polyethylene (PEX) tubing in $\frac{3}{8}$, $\frac{1}{2}$, $\frac{5}{8}$, $\frac{3}{4}$, and 1 in. nominal diameters that meet the requirements for Specifications F 876 and F 877. These fittings are intended for use in 100 psi (689.5 kPa) cold- and hot-water distribution systems operating at temperatures up to, and including, 180°F (82°C). The requirements for materials, workmanship, dimensions, and markings to be used on the fittings and rings are also included.

1.2 The values stated in inch-pound units are to be regarded as the standard. The values given in parentheses are mathematical conversions to SI units which are provided for information only and are not considered the standard.

1.3 Compliance with this specification requires that these fittings be tested and certified to Specification F 877.

1.4 *This standard does not purport to address all of the safety concerns, if any, associated with its use. It is the responsibility of the user of this standard to establish appropriate safety and health practices and determine the applicability of regulatory limitations prior to use.*

¹ This standard is under the jurisdiction of ASTM Committee F17 on Plastic Piping Systems and is the direct responsibility of Subcommittee F17.10 on Fittings. Current edition approved ~~Dec.~~ April 1, 2003⁴. Published ~~December 2003.~~ April 2004. Originally approved in 1997. Last previous edition approved in 2002³ as F 1807 – 02~~a~~³.

2. Referenced Documents

2.1 ASTM Standards:²

- B 16/B 16M Specification for Free-Cutting Brass Rod, Bar, and Shapes for Use in Screw Machines
- B 62 Specification for Composition Bronze or Ounce Metal Castings
- B 75 Specification for Seamless Copper Tube
- B 88 Specification for Seamless Copper Water Tube
- B 140/B140M Specification for Copper-Zinc-Lead (Red Brass or Hardware Bronze) Rod, Bar, and Shapes
- B 283 Specification for Copper and Copper-Alloy Die Forgings (Hot-Pressed)
- B 584 Specification for Copper Alloy Sand Castings for General Applications
- D 1600 Terminology for Abbreviated Terms Relating to Plastics
- D 2122 Test Method for Determining Dimensions of Thermoplastic Pipe and Fittings
- E 18 Test Methods for Rockwell Hardness and Rockwell Superficial Hardness of Metallic Materials
- F 412 Terminology Relating to Plastic Piping Systems
- F 876 Specification for Cross-linked Polyethylene (PEX) Tubing
- F 877 Specification for Cross-linked Polyethylene (PEX) Plastic Hot- and Cold-Water Distribution Systems

2.2 ASME Standards:³

- B1.20.1 Pipe Threads General Purpose (Inch)
- B16.18 Cast Copper Alloy Solder Joint Pressure Fittings
- B16.22 Wrought Copper and Copper Alloy Solder Joint Pressure Fittings

2.3 Manufacturer's Standardization Society Standard:⁴

- SP-104 Wrought Copper Solder Joint Pressure Fittings

2.4 NSF International Standard:⁵

- Standard No. 14 for Plastic Piping Components and Related Materials
- Standard No. 61 for Drinking Water System Components-Health Effects

3. Terminology

3.1 Definitions are in accordance with Terminology F 412 and abbreviations are in accordance with Terminology D 1600, unless otherwise indicated.

4. Classification

4.1 This specification covers one class of fittings and copper crimp rings suitable for use with four sizes of PEX tubing that meet the requirements of Specifications F 876 or F 877.

5. Materials and Manufacture

5.1 *Fittings*—The fittings shall be made from one of the following metals:

5.1.1 *Wrought Copper*—Wrought copper fittings shall be made from material meeting the requirements of Specification B 75 or B 88 for one of the following coppers: copper UNS C10200, C10300, C10800, or C12200.

5.1.2 *Cast Copper Alloys*—Cast copper alloy fittings shall be made from material meeting the requirements of Specification B 584, copper alloy UNS C84400, C83800, or C89844 or Specification B 62, copper alloy UNS C83600.

5.1.3 *Machined Brass*—Machined brass fittings shall be made from material meeting the requirements of Specification B 140/B 140M copper alloy UNS C31400 or Specification B 16/B 16M copper alloy UNS C36000.

5.1.4 *Forged Brass*—Forged brass fittings shall be made from material meeting the requirements of Specification B 283, copper alloy UNS C37700 or UNS C36500.

5.2 *Crimp Rings*—Crimp rings shall be made from copper UNS C10200 or C12200, and shall be black in color. The crimp rings shall have a minimum allowable hardness of 35 and a maximum allowable hardness of 45 on the Rockwell 15T scale when measured according to Test Methods E 18.

6. General Requirements

6.1 The following sections of Specification F 877 constitute a part of this specification.

- 6.1.1 Requirements,
- 6.1.2 Test Methods, and
- 6.1.3 Retest and Rejection.

² For referenced ASTM standards, visit the ASTM website, www.astm.org, or contact ASTM Customer Service at service@astm.org. For *Annual Book of ASTM Standards* volume information, refer to the standard's Document Summary page on the ASTM website.

³ Available from American Society of Mechanical Engineers (ASME), ASME International Headquarters, Three Park Ave., New York, NY 10016-5990.

⁴ Available from Manufacturers Standardization Society of the Valve and Fittings Industry (MSS), 127 Park St., NE, Vienna, VA 22180-4602.

⁵ Available from NSF International, P.O. Box 130140, 789 N. Dixboro Rd., Ann Arbor, MI 48113-0140.

6.2 In addition, when a section with a title identical to that referenced in 6.1 appears in this specification, it contains additional requirements that supplement those appearing in Specification F 877.

6.3 *Dimensions*—Any randomly selected fitting or fittings, and crimp ring or crimp rings, shall be used to determine dimensions. Measurements shall be made in accordance with Test Method D 2122, except when determining diameters, which is done by making measurements at four locations spaced approximately 45° apart around the circumference. Inspection and gauging of solder joint ends shall be in accordance with ASME B16.18, ASME B16.22, or MSS SP-104.

6.4 *General*—All performance tests shall be performed on assemblies of fittings, crimp rings, and PEX tubing. Fittings and crimp rings shall meet the material and dimensional requirements of this specification. PEX tubing shall meet the requirements of Specifications F 876 or F 877. Assembly of test specimens shall be in accordance with 9.1.1. Use separate sets of assemblies for each performance test requirement.

7. Dimensions

7.1 *Dimensions and Tolerances*—The dimensions and tolerances of fittings and crimp rings shall be as shown in Fig. 1, Fig. 2, Fig. 3, and Fig. 4, when measured in accordance with 6.3.

7.1.1 *Alignment*—The maximum angular variation of any opening shall not exceed 1° off the true centerline axis.

7.1.2 *Fittings with Solder Joint Ends*—Solder joint ends shall be in accordance with ASME B16.22, ASME B16.18, or MSS SP-104.

7.1.3 *Tapered Threaded Ends*—Fitting threads shall be right-hand conforming to ASME B1.20.1. They shall be taper threads (NPT).

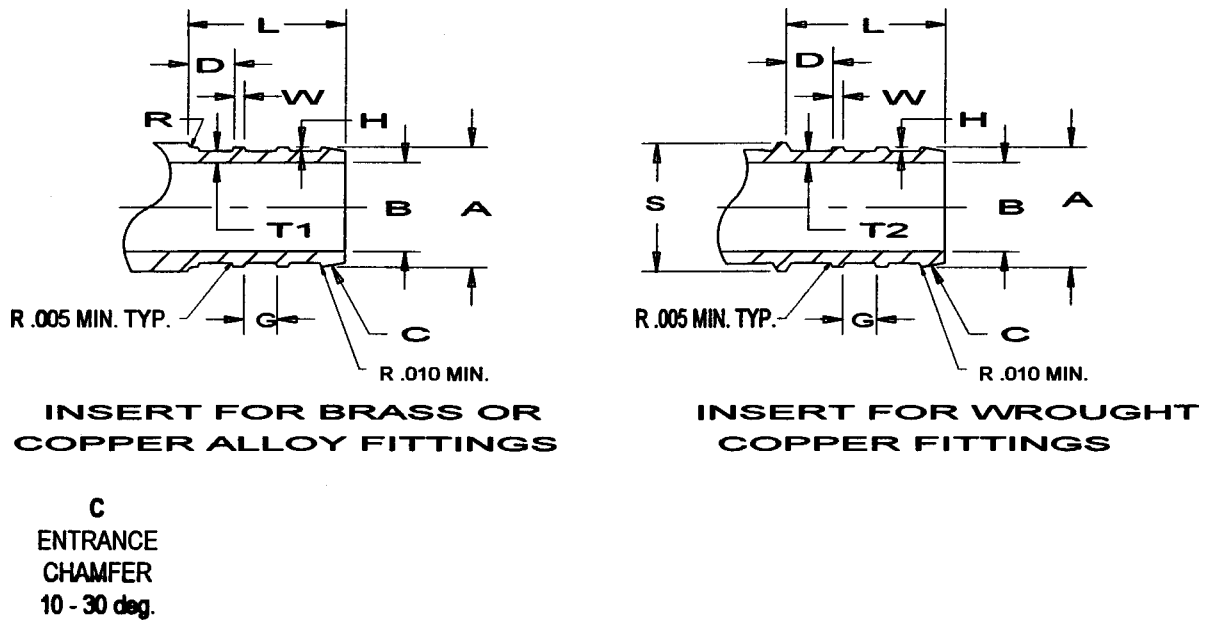

| Size | A Outside Diameter of Rib ^A | B Minimum ID | D Distance to First Rib ^B | L Minimum Insert Length ^A | H Minimum Rib Height | Number of Ribs ^C | W Rib ^D Width | G Rib Spacing Typical | T1 Minimum Wall ^E | T2 Minimum Wall ^E | R Minimum Radius | S Minimum Average Diameter ^F | Maximum Flash and Mismatch, Total on Crest Di- ameter ^{G,H} |
|---------|---|--------------------|--|---|-------------------------------|--------------------------------|-----------------------------|-----------------------------|------------------------------------|------------------------------------|------------------------|--|---|
| 3/8 in. | 0.345 ± 0.004 | 0.230 | 0.180–0.224 | 0.625 | 0.013 | 2 | 0.03–0.05 | 0.120–0.145 | 0.025 | 0.025 | 0.02 | 0.369 | 0.005 |
| 1/2 in. | 0.471 ± 0.004 | 0.350 | 0.180–0.224 | 0.625 | 0.013 | 2 | 0.03–0.05 | 0.120–0.145 | 0.028 | 0.028 | 0.02 | 0.495 | 0.005 |
| 5/8 in. | 0.570 ± 0.004 | 0.451 | 0.180–0.224 | 0.625 | 0.013 | 2 | 0.03–0.05 | 0.120–0.145 | 0.032 | 0.032 | 0.02 | 0.595 | 0.005 |
| 3/4 in. | 0.667 ± 0.004 | 0.530 | 0.180–0.224 | 0.625 | 0.013 | 2 | 0.03–0.05 | 0.120–0.145 | 0.037 | 0.032 | 0.02 | 0.691 | 0.005 |
| 1 in. | 0.856 ± 0.004 | 0.710 | 0.180–0.224 | 0.795 | 0.015 | 3 | 0.03–0.05 | 0.120–0.145 | 0.041 | 0.035 | 0.02 | 0.880 | 0.005 |

^A Measured from shoulder of rib to tube stop.
^B Fitting shall be designed with sufficient overall dimensions to allow proper use of crimp tool without interference with previously completed crimps on the same fitting.
^C Lead chamfer area is not considered a rib.
^D Rib sides may be angled.
^E Applies to entire fitting, not just insert area.
^F The raised area serves as a tube stop for wrought copper fittings that do not have a shoulder.
^G The maximum flash and mismatch at the root diameter between the ribs may not exceed 30 % of the rib height.
^H The total flash and mismatch is assumed to be the difference between the dimensions X and Y (see Fig. 2). These dimensions may be measured with appropriate calipers or micrometers. See Fig. 3 for a graphic definition of flash and mismatch created by imperfection in die half interfaces.

FIG. 1 Fitting Insert Dimensions and Tolerances

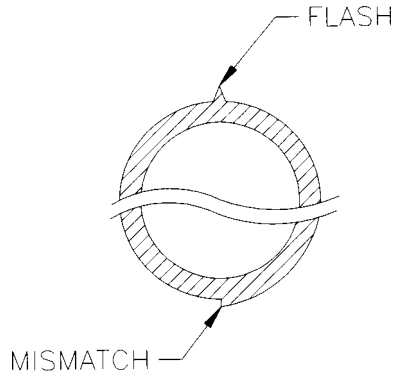

FIG. 2 Flash and Mismatch Created by Imperfection in Die Half Interfaces

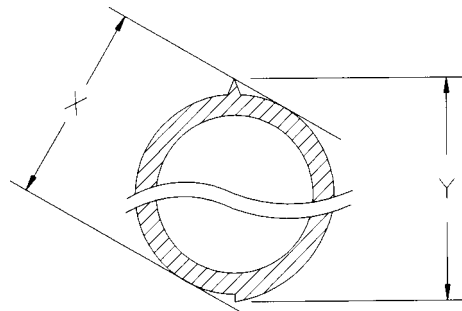
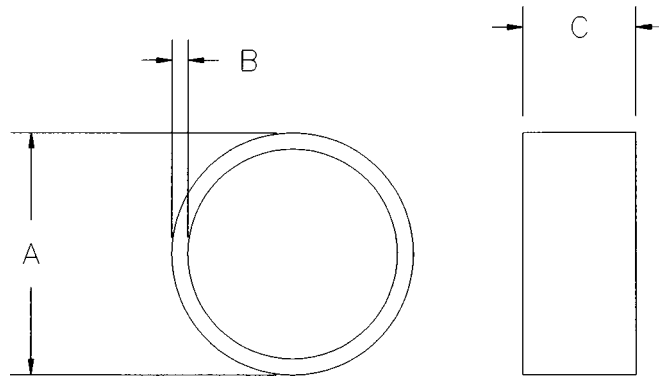

FIG. 3 Total Flash and Mismatch



| Size | A Average Outside Diameter ^{A,B} | B | | C Width |
|---------|---|-----------------------------|-----------------------------|---------------|
| | | Wall Thickness ^B | Average Wall ^{C,D} | |
| 3/8 in. | 0.630 ± 0.003 | 0.058 ± 0.0035 | ± 0.002 | 0.325 ± 0.020 |
| 1/2 in. | 0.750 ± 0.003 | 0.056 ± 0.0035 | ± 0.002 | 0.325 ± 0.020 |
| 5/8 in. | 0.875 ± 0.003 | 0.054 ± 0.0035 | ± 0.002 | 0.325 ± 0.020 |
| 3/4 in. | 1.000 ± 0.003 | 0.056 ± 0.0035 | ± 0.002 | 0.325 ± 0.020 |
| 1 in. | 1.250 ± 0.003 | 0.049 ± 0.0035 | ± 0.002 | 0.365 ± 0.020 |

^A All dimensions shall be measured with appropriate micrometers, such as pin or ball micrometers for wall and outside diameter micrometers with flat anvils or vernier calipers shall be used to measure outside diameters and width of rings.

^B The average measurement is obtained from measurements taken in at least two different circumferential positions which are equally spaced around the circumference.

^C The average wall measurement is obtained from measurements taken in eight different positions which are equally spaced around the circumference.

^D The maximum out-of-roundness of the crimp ring shall not inhibit assembly with the fitting and tubing. The crimp ring dimensions after crimping shall comply with Table 1.

FIG. 4 Copper Crimp Ring Dimensions Before Crimping^{A, B, C, D}

8. Workmanship, Finish, and Appearance

8.1 The sealing surfaces of the insert shall be smooth and free of foreign material. Fitting walls shall be free of cracks, holes, blisters, voids, foreign inclusions, or other defects that are visible to the unaided eye and affect the wall integrity.

9. Assembly

9.1 *Crimp Joints*—Insert fittings shall be joined to PEX tubing by the compression of a copper crimp ring around the outer circumference of the tubing, forcing the tubing material into annular spaces formed by ribs on the fitting. Insert fittings and crimp rings shall meet the dimensional and material requirements of this standard. PEX tubing shall meet the requirements of Specifications F 876 or F 877. The dimensions and out-of-roundness of the crimp ring, after it has been crimped, shall be in accordance with Table 1.

9.1.1 *Crimping Procedure*—The crimping procedure shall be as follows: slide the crimp ring onto the tubing, insert the ribbed end of the fitting into the end of the tubing until the tubing contacts the shoulder of the fitting or tube stop. The crimp ring shall then be positioned on the tubing so the edge of the crimp ring is $\frac{1}{8}$ to $\frac{1}{4}$ in. (3.2 to 6.4 mm) from the end of the tube. The jaws of the crimping tool shall be centered over the crimp ring and the tool shall be held so that the crimping jaws are approximately perpendicular to the axis of the barb. The jaws of the crimping tool shall be closed around the crimp ring, compressing the crimp ring onto the tubing. The crimp ring shall not be crimped more than once. Each crimp shall be checked to determine conformance to the after-crimped dimensional requirements of Table 1.

TABLE 1 Crimp Ring Dimensions After Crimping on Tube/Fitting Assembly

| Nominal Tube Size Insert End, in. | Final Crimped Outside Diameter ^{A,B} Minimum, | | Maximum, in. (mm) |
|--------------------------------------|---|--|-------------------|
| | in. (mm) | | |
| $\frac{3}{8}$ | 0.580 (14.7) | | 0.595 (15.1) |
| $\frac{1}{2}$ | 0.700 (17.8) | | 0.715 (18.2) |
| $\frac{5}{8}$ | 0.815 (20.7) | | 0.830 (21.1) |
| $\frac{3}{4}$ | 0.945 (24.0) | | 0.960 (24.4) |
| 1 | 1.175 (29.8) | | 1.190 (30.2) |

^A For all diameters except for the area of scoring caused by the crimping tool.

^B The maximum out-of-roundness as measured by the difference between the minimum crimped outside diameter and the maximum crimped outside diameter shall not exceed 0.006 in. (0.150 mm).

10. Product Marking

10.1 *Quality of Marking*—The marking shall be applied to the fittings in such a manner that it remains legible after installation and inspection.

10.2 *Content of Marking*:

10.2.1 Marking on fittings shall include manufacturer's name or trademark, or some other identifying mark, and if size permits, PEX or the ASTM standard number, or both.

10.2.1.1 Where recessed marking is used on fittings, care shall be taken to see that the marking shall not cause cracks or reduce the wall thickness below the minimum specified.

10.2.2 Marking on packaging shall include manufacturer's name, fitting size, and ASTM F 1807.

10.2.3 Marking on crimp rings shall include manufacturer's trademark, or some other identifying mark, and ASTM F1807.

11. Quality Assurance

11.1 When the product or product packing is marked with the ASTM designation F 1807, the manufacturer affirms that the product was manufactured, inspected, sampled, and tested in accordance with this specification, and has been found to meet its requirements.

12. Keywords

12.1 cold and hot water distribution; copper crimp rings; cross-linked polyethylene; metal insert fittings; PEX

SUPPLEMENTARY REQUIREMENTS

This requirement applies whenever a regulatory authority or user calls for product to be used to convey, or be in contact with, potable water.

S1. *Potable Water Requirements*—Products intended for the transport of potable water shall be evaluated, tested, and certified for conformance with ANSI/NSF Standard No. 61, or the health effects portion of NSF Standard No. 14, by an acceptable certifying organization, when required by the regulatory authority having jurisdiction.

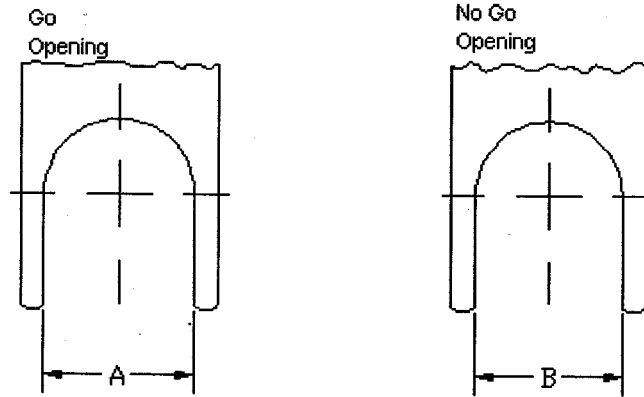

| Size, in. | Gage Opening | |
|-----------|----------------------|----------------------|
| | Go (A) | No Go (B) |
| 3/8 | 0.595 + .000/ - .002 | 0.580 + .002/ - .000 |
| 1/2 | 0.715 + .000/ - .002 | 0.700 + .002/ - .000 |
| 5/8 | 0.830 + .000/ - .002 | 0.815 + .002/ - .000 |
| 3/4 | 0.960 + .000/ - .002 | 0.945 + .002/ - .000 |
| 1 | 1.190 + .000/ - .002 | 1.175 + .002/ - .000 |

FIG. X1.1 Go/No-Go Gages

APPENDIX

(Nonmandatory Information)

X1. GO/NO-GO CRIMP GAGE

X1.1 This appendix provides dimensions for gages to check the after-crimped dimensions of the four sizes of crimp connections covered by this specification. This information has been taken from gages in current production at the time of the writing of this specification. Gages shown here provide only a reference for the maximum and minimum diameters of the crimped ring and do not provide a check for the out-of-round dimension. Additionally, calipers or micrometers may be used.

X1.2 Crimp gages manufactured according to the dimensions shown in Fig. X1.1 will ensure that crimps checked with these gages will not be larger or smaller than those allowed by this specification.

X1.3 *Use of the Crimp GO/NO-GO Gage*—Slide the correct size GO section of the gage over the crimped ring in at least two places and attempt to slide the NO-GO section of the gage over the crimped ring in at least two places (see Note X1.1). The GO section of the gage should slide over the crimped ring easily and the NO-GO section should not slide over the crimped ring. If the GO section does not slide over the ring, or the NO-GO section slides over the ring, the crimped joint must be replaced. Additionally, the crimp tool may need adjustment; follow the recommendations of the tool manufacturer.

NOTE X1.1—Most of the commercially available crimp tools will produce a scoring mark on the ring where the jaws of the tool overlap. Gaging the crimped ring on this scoring mark will generally give a false reading. Gage the crimped ring away from the scoring mark for best accuracy.

ASTM International takes no position respecting the validity of any patent rights asserted in connection with any item mentioned in this standard. Users of this standard are expressly advised that determination of the validity of any such patent rights, and the risk of infringement of such rights, are entirely their own responsibility.

This standard is subject to revision at any time by the responsible technical committee and must be reviewed every five years and if not revised, either reapproved or withdrawn. Your comments are invited either for revision of this standard or for additional standards and should be addressed to ASTM International Headquarters. Your comments will receive careful consideration at a meeting of the responsible technical committee, which you may attend. If you feel that your comments have not received a fair hearing you should make your views known to the ASTM Committee on Standards, at the address shown below.

This standard is copyrighted by ASTM International, 100 Barr Harbor Drive, PO Box C700, West Conshohocken, PA 19428-2959, United States. Individual reprints (single or multiple copies) of this standard may be obtained by contacting ASTM at the above address or at 610-832-9585 (phone), 610-832-9555 (fax), or service@astm.org (e-mail); or through the ASTM website (www.astm.org).