



Standard Specification for Cold Expansion Fittings with PEX Reinforcing Rings for Use with Cross-linked Polyethylene (PEX) Tubing¹

This standard is issued under the fixed designation F 1960; the number immediately following the designation indicates the year of original adoption or, in the case of revision, the year of last revision. A number in parentheses indicates the year of last reapproval. A superscript epsilon (ϵ) indicates an editorial change since the last revision or reapproval.

1. Scope

1.1 This specification covers cold expansion fittings and cross-linked (PEX) reinforcing rings for use with cross-linked polyethylene (PEX) plastic tubing in $\frac{3}{8}$, $\frac{1}{2}$, $\frac{5}{8}$, $\frac{3}{4}$, 1, $1\frac{1}{4}$, and $1\frac{1}{2}$ in. nominal diameters that meet the requirements of Specifications F 876 and F 877. These fittings are intended for use in 100 psi (690 kPa) cold- and hot-water distribution systems operating at temperatures up to and including 180°F (82°C). The system is comprised of a PEX reinforcing ring and a cold expansion fitting. Included are the requirements for materials, workmanship, dimensions, and markings to be used on the fitting components. The components covered by this specification are intended for use in residential and commercial, hot and cold, potable water distribution systems as well as sealed central heating, including under-floor-heating systems.

1.2 The values stated in inch-pound units are to be regarded as the standard. The values given in parentheses are mathematical conversions to SI units which are provided for information only and are not considered standard.

1.3 *This standard does not purport to address all of the safety concerns, if any, associated with its use. It is the responsibility of the user of this standard to establish appropriate safety and health practices and determine the applicability of regulatory limitations prior to use.*

2. Referenced Documents

2.1 ~~ASTM Standards:~~

¹ This specification is under the jurisdiction of ASTM Committee F17 on Plastic Piping Systems and is the direct responsibility of Subcommittee F17.10 on Fittings. Current edition approved April 10, 2003₄. Published ~~July 2003~~; May 2004. Originally approved in 1999. Last previous edition approved in 2002 as F 1960 – 02b.

- ~~A 351 Specification for Castings, Austenitic, Austenitic-Ferritic (Duplex), for Pressure-Containing Parts Standards:~~²
- B 16 Specification for Free-Cutting Brass Rod, Bar, and Shapes for Use in Screw Machines
- B 140/B 140M Specification for Copper-Zinc-Lead (Leaded Red Brass or Hardware Bronze) Rod, Bar, and Shapes
- B 283 Specification for Copper and Copper-Alloy Die Forging (Hot Pressed)
- B 584 Specification for Copper Alloy Sand Castings for General Applications
- D 792 Test Methods for Density and Specific Gravity (Relative Density) of Plastics by Displacement
- D 1505 Test Method for Density of Plastics by the Density-Gradient Technique
- D 1600 Terminology for Abbreviated Terms Relating to Plastics
- D 2122 Test Method for Determining Dimensions of Thermoplastic Pipe and Fittings
- D 2765 Test Methods for Determination of Gel Content and Swell Ratio of a Crosslinked Ethylene Plastics
- ~~D 3045 Practice for Heat Aging of Plastics Without Load~~⁶
- ~~D 6394 Specification for Sulfone Plastics (SP)I- Load~~
- F 412 Terminology Relating to Plastic Piping Systems
- F 876 Specification for Crosslinked Polyethylene (PEX) Tubing
- F 877 Specification for Crosslinked Polyethylene (PEX) Plastic Hot and Cold-Water Distribution Systems
- 2.2 *Military Standard:*
- MIL-STD-P46120A Polysulfone GF120³
- 2.3 *ANSI Standard:*
- B1.20 Pipe Threads General Purpose⁴
- B16.18 Cast Copper Alloy Solder Joint Pressure Fittings
- B16.22 Wrought Copper and Copper Alloy Solder Joint Pressure Fittings
- 2.4 *NSF Standards:*
- NSF 14 for Plastic Piping Components and Related Materials⁵
- NSF 61 for Drinking Water System Components-Health Effects⁵
- 2.5 *Manufacturers' Standardization Society Standards:*
- SP 104 Wrought Copper Solder Joint Pressure Fittings⁶

3. Terminology

3.1 *Definitions*— Definitions are in accordance with Terminology F 412 and abbreviations are in accordance with Terminology D 1600, unless otherwise indicated.

3.1.1 *PEX reinforcing rings*—cross-linked polyethylene rings used to add contraction force around the cold expansion fittings.

4. Classification

4.1 This specification covers one class of cold expansion fittings with PEX reinforcing rings suitable for use with PEX tubing that meets the requirements of Specifications F 876 and F 877.

5. Materials and Manufacture

5.1 Cold expansion fittings shall be made from one of the following materials:

~~5.1.1 Brass:~~

~~5.1.1.1~~

~~5.1.1.1.1~~ *Machined Brass*— Machined brass fittings shall be made from material meeting the requirements of Specification B 140 copper alloy UNS C31400 or Specification B 16 copper alloy UNS C36000.

~~5.1.1.2 Forged Brass~~— Forged brass fittings shall be made from material meeting the requirements of Specification B 283 copper alloy UNS C37700 or UNS C89844.

~~5.1.1.3 Sand Casted Brass~~—Sand casted brass fittings shall be made from material meeting the requirements of Specification B 584 copper alloy UNS C84400 or other approved material meeting the requirements of Specification B 584.

~~5.1.2 Sulfone:~~

~~5.1.2.1~~

~~5.1.2.1.1~~ *20 % Glass-Filled Polysulfone* —Glass-filled polysulfone fittings shall be made from materials meeting the requirements of MIL-STD-P46120A Polysulfone GF120.

² For referenced ASTM standards, visit the ASTM website, www.astm.org, or contact ASTM Customer Service at service@astm.org. For *Annual Book of ASTM Standards*, Vol 01-02, volume information, refer to the standard's Document Summary page on the ASTM website.

Annual Book of ASTM Standards, Vol 02-01.

³ Available from Standardization Documents Order Desk, Bldg. 4 Section D, 700 Robins Ave., Philadelphia PA 19111-5094, Attn: NPODS.

Annual Book of ASTM

⁴ Available from the American National Standards, Vol 08-01, Institute, 11 West 42nd St., 13th Floor, New York, NY, 10036.

Annual Book of ASTM Standards, Vol 08-04.

⁵ Available from the National Sanitation Foundation (NSF International), PO Box 1468, Ann Arbor, MI, 48106.

⁶ *Annual Book* Available from *Manufacturers' Standardization Society of ASTM Standards*, Vol 08-02, the Valve and Fittings Industry 127 Park St. NE Vienna, VA 22180

~~5.1.2.2 Unreinforced Sulfone Plastic (SP)—The material shall be unreinforced group 01 or 03; class 1; grade 1, 2, or 3 for group 03 or grade 1, 2, 3, 4, 5 or 6 for group 01 as specified in Specification D 6394. Material may also be a blend of two or more of the specified groups.~~

~~5.1.2.3 Material must meet all requirements of this specification. the ratio of rework material to total material shall not exceed 25 %.~~

5.2 Reinforcing rings shall be made from PEX material meeting the performance requirements of 6.1.

~~5.3 Stainless Steel—fittings shall be made from material meeting the requirements of Specification A 351 stainless steel UNS J92800.~~

6. General Requirements

6.1 The following sections of Specification F 877 constitute a part of this specification.

6.1.1 Requirements,

6.1.2 Test Methods, and

6.1.3 Retest and Rejection.

6.2 In addition, when a section with a title identical to that referenced in 6.1, above, appears in this specification, it contains additional requirements that supplement those appearing in F 877.

6.3 *System Performance Requirements* :

6.3.1 *General*—All performance tests shall be performed on assemblies of fittings, PEX reinforcing rings and PEX tubing. Fittings and reinforcing rings shall meet the material and dimensional requirements of this specification. PEX tubing shall meet the requirements of Specifications F 876 and F 877. Assembly of test specimens shall be in accordance with 10.1. Each assembly shall contain at least two joints. Use separate sets of assemblies for each performance test requirement.

6.3.2 *Dimensions*—Any randomly selected fitting or fittings and PEX reinforcing rings shall be used to determine dimensions. Measurements shall be made in accordance with Test Method D 2122, except determine diameter by making measurements at four locations spaced at approximately 45° apart around the circumference. Inspection and gauging of solder joint ends shall be accordance with ANSI B16.18, ANSI B16.22, or MSS SP-104.

7. Performance Requirements

7.1 *PEX Reinforcing Rings*:

7.1.1 *Density*—When determined in accordance with 11.1, the PEX reinforcing rings shall have a density in the range from 926 to 940 kg/m³.

7.1.2 *Degree of Cross-linking*—When tested in accordance with 11.2, the degree of cross-linking for PEX reinforcing rings shall be within the range from 70 to 89% inclusive.

7.1.3 *Stabilizer Migration Resistance*—When tested in accordance with 11.3, the time t^2 , shall be at least 50% of the time, t^1 .

8. Dimensions

8.1 *Dimensions and Tolerances*—The dimensions and tolerances of fittings and PEX reinforcing rings shall be as shown in Figs. 1 and 2 and Fig. 4 when measured in accordance with 6.3.2.

8.1.1 *Alignment*—The maximum angular variation of any opening shall not exceed 1° off the true centerline axis.

8.1.2 *Fittings with Solder Joint Ends*—Solder joint ends shall be in accordance with ANSI B16.22, ANSI B16.18 or MSS SP-104.

8.1.3 *Tapered Threaded Ends*—Fitting threads shall be right-hand conforming to ANSI B1.20.1. They shall be taper threads (NPT).

9. Workmanship, Finish and Appearance

9.1 The fittings shall be made from compounds that are homogeneous throughout. The sealing surfaces of the insert shall be smooth and free of foreign material. The fitting walls shall be free of cracks, holes, blisters, voids, foreign inclusions, or other defects that are visible to the naked eye and that affect wall integrity.

10. Assembly

10.1 *Cold Expansion Joints*—Fittings shall be joined to PEX tubing by the contraction of the tubing and reinforcing ring over the insert of the cold expansion fitting. Fittings and PEX reinforcing rings shall meet the dimensional and material requirements of this standard. PEX tubing shall meet the requirements of Specification F 876 or F 877.

10.2 *Expansion Tool*— The expansion tool shall expand the PEX tubing and reinforcing ring to a maximum inside diameter as listed in Table 1. The expanded tubing shall be round to ensure uniform contraction of the tubing around the cold expansion fitting. The expansion tool shall be inspected for wear according to the manufacturer's instructions.

10.3 *Procedure*:

10.3.1 *Assembly of Connections*—Affix the cold expansion fitting to the PEX tubing by sliding the PEX reinforcing ring onto the tubing and positioning the ring so that the end of the ring overhangs the end of the tubing a maximum of 1/16 in. (1.6 mm). Insert the expansion head into the tubing as far as it will go. Holding the tool so that the centerline of the expansion head is

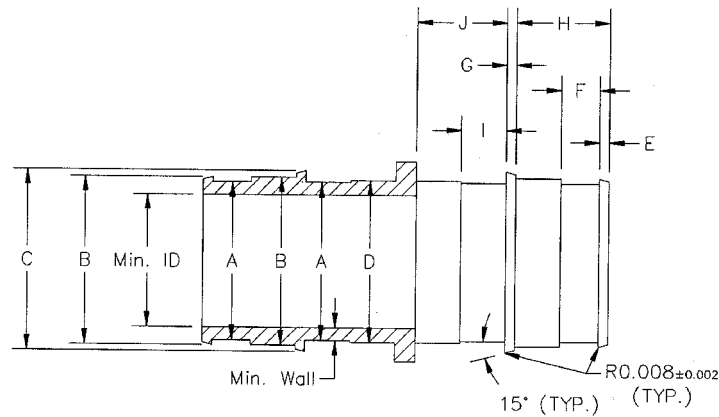

NOTES: BREAK ALL INTERNAL CORNERS 0.010 – 0.015
ALL DIAMETER CONCENTRICITY 0.005 TIR

FIG. 1 Brass and Stainless Steel Insert Dimensions and Tolerances

Brass Dimensions

Size	Min. Wall	Min. ID	A	B	C	D	E	F	G	H	I	J
3/8 in.	0.047	0.260	0.395	0.441	0.480	0.427	0.067	0.128	0.067	0.325	0.127	0.286
			0.375	0.433	0.472	0.407	0.051	0.108	0.051	0.305	0.107	0.266
1/2 in.	0.057	0.378	0.533	0.579	0.618	0.565	0.067	0.128	0.067	0.404	0.167	0.325
			0.513	0.571	0.610	0.545	0.051	0.108	0.051	0.384	0.147	0.305
5/8 in.	0.057	0.500	0.655	0.697	0.748	0.683	0.067	0.167	0.067	0.482	0.207	0.404
			0.635	0.689	0.740	0.663	0.051	0.147	0.051	0.462	0.187	0.384
3/4 in.	0.057	0.595	0.748	0.795	0.874	0.782	0.067	0.207	0.067	0.522	0.246	0.443
			0.728	0.787	0.866	0.762	0.051	0.187	0.051	0.502	0.226	0.423
1 in.	0.072	0.795	0.985	1.032	1.110	0.998	0.067	0.246	0.067	0.640	0.285	0.561
			0.965	1.024	1.102	0.978	0.051	0.226	0.051	0.620	0.265	0.541
1-1/4 in.	0.075	0.960	1.139	1.266	1.352	1.217	0.080	0.299	0.080	0.781	0.348	0.684
			1.159	1.276	1.362	1.237	0.064	0.279	0.064	0.761	0.328	0.664
1-1/2 in.	0.095	1.084	1.324	1.382	1.494	1.349	0.093	0.351	0.093	0.919	0.408	0.805
			1.304	1.374	1.486	1.329	0.077	0.331	0.077	0.899	0.388	0.785

approximately in line with the centerline of the tubing, operate the tool until the tubing and reinforcing ring are fully expanded. After completing the expansion process, remove the expansion tool and insert the cold expansion fitting until the tubing hits the shoulder of the fitting or the tube stop. Hold the fitting in place until the tubing contracts sufficiently to hold the fitting in place.

10.3.2 *Improper Connections*—If the insert fitting was not fully inserted to its shoulder or tube stop or the reinforcing ring was not placed in accordance with 10.3.1, remove the tubing and ring from the fitting and trim 2 in. from the tubing. Using a new reinforcing ring, repeat the procedure in 10.3.1.

11. Reinforcing Ring Testing Methods

11.1 *Density*—Determine the density of the reinforcing ring material in accordance with Test Method D 1505, or Test Method D 792, using three specimens.

11.2 *Degree of Cross-Linking*—Determine the degree of cross-linking in accordance with Test Method D 2765, Method B except for the following: during sample preparation, place a reinforcing ring in a lathe with automatic feeding. Shave a strip approximately 0.004 in.-thick that consists of the full thickness of the ring. For the purpose of this specification, the degree of cross-linking (V) is defined as 100 % minus the extract percent = V.

11.3 *Stabilizer Migration Resistance* —Cut two 0.4-in. (10-mm) long samples from the reinforcing ring. Store one of the samples covered at room temperature for 1000 h. Place the other sample in a round-bottom flask with large-mouth, ground-glass or cork joint. The flask size shall be 500 mL for each test sample. Fill with distilled water. Put the flask in a heating mantle to heat the flask to boil water. Put a reflux condenser with ground-glass or cork joint to fit into the flask. Boil for 1000 h but change the distilled water at even intervals two times per week. Place the two samples hanging on a thin steel rod (approximately 0.1-in. (2.5-mm) diameter) in an oven at 311°F (155°C) in accordance with Practice D 3045. Let the samples hang in the oven until both have failed. Failure is an obvious change in the shape or color of the samples, observed visually. The start of melting of surfaces, drip formation, or cracks indicates a shape change. Color change must be significant if it shall be counted as a failure. Observation of the tube samples must be made at intervals making it possible to read the time-to-failure within 15 % of the total testing time. Measure the time-to-failure of the unboiled sample (t_1) and the boiled sample (t_2).

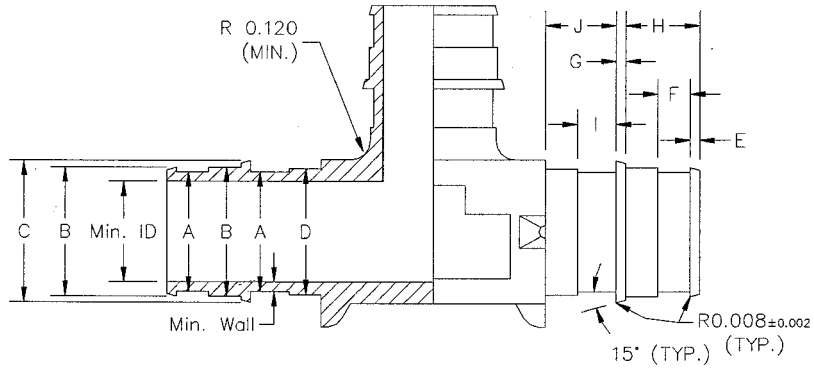

NOTE: BREAK ALL INTERNAL CORNERS 0.010 – 0.015
ALL DIAMETER CONCENTRICITY 0.005 TIR

FIG. 2-S Polysulfone Insert Dimensions and Tolerances

Polysulfone Dimensions

Size	Min. Wall	Min. ID	A	B	C	D	E	F	G	H	I	J	Max Flash and Mismatch
3/8 in.	0.047	0.268	0.402	0.441	0.480	0.427	0.067	0.128	0.067	0.325	0.128	0.306	0.005
			0.382	0.433	0.472	0.407	0.051	0.108	0.051	0.305	0.108	0.266	
1/2 in.	0.057	0.385	0.540	0.579	0.618	0.565	0.067	0.128	0.067	0.404	0.167	0.345	0.005
			0.520	0.571	0.610	0.545	0.051	0.108	0.051	0.384	0.147	0.305	
5/8 in.	0.057	0.494	0.648	0.697	0.748	0.683	0.067	0.167	0.067	0.482	0.207	0.424	0.005
			0.628	0.689	0.740	0.663	0.051	0.147	0.051	0.462	0.187	0.384	
3/4 in.	0.057	0.590	0.755	0.795	0.874	0.782	0.067	0.207	0.067	0.522	0.246	0.463	0.005
			0.735	0.787	0.866	0.762	0.051	0.187	0.051	0.502	0.226	0.423	
1 in.	0.072	0.788	0.992	1.032	1.110	0.998	0.067	0.246	0.067	0.640	0.286	0.581	0.005
			0.972	1.024	1.102	0.978	0.051	0.226	0.051	0.620	0.266	0.541	
1-1/4 in.	0.075	0.970	1.139	1.266	1.352	1.217	0.080	0.299	0.080	0.781	0.348	0.704	0.005
			1.159	1.276	1.362	1.237	0.064	0.279	0.064	0.761	0.328	0.664	
1-1/2 in.	0.095	1.084	1.328	1.382	1.494	1.349	0.093	0.351	0.093	0.919	0.408	0.825	0.005
			1.308	1.374	1.486	1.329	0.077	0.331	0.077	0.899	0.388	0.785	

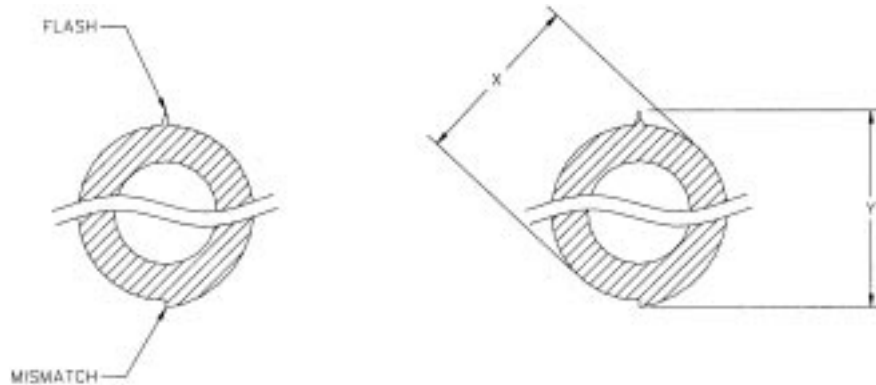

FIG. 3 Flash and Mismatch Created by Imperfection in Die Half Interfaces

12. Product Marking

12.1 Cold Expansion Fitting:

12.1.1 *Quality of Marking*—The marking shall be applied to the fittings in such a manner that it remains legible after installation and inspection.

12.1.2 *Content of Marking*:

12.1.2.1 Manufacturer's name or trademark, or both,

12.1.2.2 This designation, F 1960,

12.1.2.3 Certification mark or seal of the laboratory making the evaluation for this purpose, and

12.1.2.4 Nominal size.

12.1.3 Where recessed marking is used on the fittings, in no case shall the marking cause cracks or reduce the wall thickness below the minimum specified.

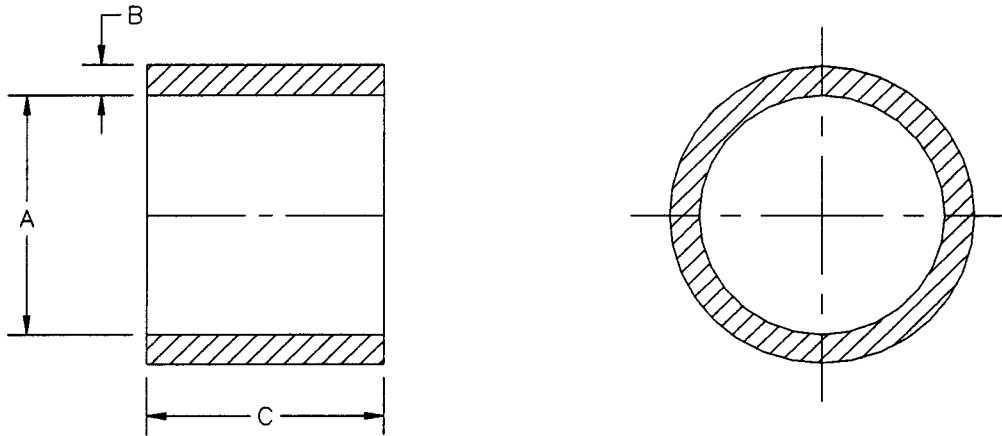

Tube Size	Inside Diameter (A)	Max. Out of Round	Wall Thickness (B)	Width (C)
3/8"	0.486 ± 0.004	0.012	0.123 ± 0.006	0.540 ± 0.020
1/2"	0.633 ± 0.003	0.012	0.123 ± 0.005	0.630 ± 0.020
5/8"	0.757 ± 0.003	0.012	0.123 ± 0.005	0.787 ± 0.020
3/4"	0.882 ± 0.004	0.016	0.123 ± 0.005	0.866 ± 0.020
1"	1.134 ± 0.004	0.020	0.143 ± 0.006	1.102 ± 0.020
1-1/4"	1.382 ± 0.004	0.020	0.138 ± 0.006	1.349 ± 0.030
1-1/2"	1.634 ± 0.004	0.020	0.138 ± 0.006	1.605 ± 0.030

NOTE 1—All dimensions shall be measured with appropriate micrometers, such as pin or ball micrometers for wall thickness and outside diameter micrometers with flat anvils to measure outside diameter and width of rings.

NOTE 2—The maximum out of roundness of the PEX reinforcing ring shall not inhibit assembling with the tubing and fitting.

NOTE 3—Rings shall be free of burrs and inclusions.

FIG. 4 PEX Reinforcing Ring Dimensions, in.

TABLE 1 Maximum Expansion Head Dimensions

Tube Size, in.	Maximum Diameter Expanded, in. (mm)
3/8	0.579 in. (14.7 mm)
1/2	0.710 in. (18.0 mm)
5/8	0.866 in. (22.0 mm)
3/4	1.025 in. (26.0 mm)
1	1.260 in. (32.0 mm)
1-1/4	1.417 in. (36.0 mm)
1-1/2	1.713 in. (43.5 mm)

12.2 PEX Reinforcing Rings—The product shall be marked with the following information:

12.2.1 Manufacturer's name or trademark, or both,

12.2.2 Nominal size,

12.2.3 Certification mark or seal of the laboratory making the evaluation for this purpose, and

12.2.4 This Designation, F 1960.

13. Quality Assurance

13.1 When the product is marked with this designation (ASTM F 1960), the manufacturer affirms that the product was manufactured, inspected, sampled, and tested in accordance with this specification and has been found to meet the requirements of this specification.

14. Keywords

14.1 cold expansion fittings; cross-linked polyethylene; hot and cold water distribution; PEX; PEX reinforcing rings

SUPPLEMENTARY REQUIREMENTS**POTABLE WATER REQUIREMENT**

This requirement applies whenever a regulatory authority or user calls for product to be used to convey or be in contact with potable water.

S1.1 Products intended for the transport of potable water shall be evaluated, tested, and certified for compliance with ANSI/NSF Standard No. 61 or the health effects portion of NSF Standard No. 14 by an acceptable certifying organization when required by the regulatory authority having jurisdiction.

ASTM International takes no position respecting the validity of any patent rights asserted in connection with any item mentioned in this standard. Users of this standard are expressly advised that determination of the validity of any such patent rights, and the risk of infringement of such rights, are entirely their own responsibility.

This standard is subject to revision at any time by the responsible technical committee and must be reviewed every five years and if not revised, either reapproved or withdrawn. Your comments are invited either for revision of this standard or for additional standards and should be addressed to ASTM International Headquarters. Your comments will receive careful consideration at a meeting of the responsible technical committee, which you may attend. If you feel that your comments have not received a fair hearing you should make your views known to the ASTM Committee on Standards, at the address shown below.

This standard is copyrighted by ASTM International, 100 Barr Harbor Drive, PO Box C700, West Conshohocken, PA 19428-2959, United States. Individual reprints (single or multiple copies) of this standard may be obtained by contacting ASTM at the above address or at 610-832-9585 (phone), 610-832-9555 (fax), or service@astm.org (e-mail); or through the ASTM website (www.astm.org).