



Standard Test Methods for Rubber—Viscosity, Stress Relaxation, and Pre-Vulcanization Characteristics (Mooney Viscometer)¹

This standard is issued under the fixed designation D 1646; the number immediately following the designation indicates the year of original adoption or, in the case of revision, the year of last revision. A number in parentheses indicates the year of last reapproval. A superscript epsilon (ϵ) indicates an editorial change since the last revision or reapproval.

This standard has been approved for use by agencies of the Department of Defense.

1. Scope

1.1 These test methods describe procedures for measuring a property called Mooney viscosity. Mooney viscosity is defined as the shearing torque resisting rotation of a cylindrical metal disk (or rotor) embedded in rubber within a cylindrical cavity. The dimensions of the shearing disk viscometer, test temperatures, and procedures for determining Mooney viscosity are defined in these test methods.

1.2 When disk rotation is abruptly stopped, the torque or stress on the rotor decreases at some rate depending on the rubber being tested and the temperature of the test. This is called 'stress relaxation' and these test methods describe a test method for measuring this relaxation.

NOTE 1—Viscosity as used in these test methods is not a true viscosity and should be interpreted to mean Mooney viscosity, a measure of shearing torque averaged over a range of shearing rates. Stress relaxation is also a function of the test configuration and for these test methods the results are unique to the Mooney viscometer.

1.3 When compounded rubber is placed in the Mooney viscometer at a temperature at which vulcanization may occur, the vulcanization reaction produces an increase in torque. These test methods include procedures for measuring the initial rate of rubber vulcanization.

1.4 The values stated in SI units are to be regarded as the standard. The values given in parentheses are for information only.

1.5 ISO Standard 289 Parts 1 and 2 also describes the determination of Mooney viscosity and pre-vulcanization characteristics. In addition to a few insignificant differences there are major technical differences between ISO 289 and this test method in the way samples are prepared on the mill prior to running a Mooney viscosity test. This can result in different viscosity values for some rubbers.

1.6 *This standard does not purport to address all of the safety concerns, if any, associated with its use. It is the responsibility of the user of this standard to establish appropriate safety and health practices and determine the applica-*

bility of regulatory limitations prior to use.

2. Referenced Documents

2.1 ASTM Standards:

D 1349 Practice for Rubber—Standard Temperatures for Testing²

D 1418 Practice for Rubber and Rubber Latices—Nomenclature²

D 1485 Test Methods for Rubber from Natural Sources—Sampling and Sample Preparation²

D 3182 Practice for Rubber—Materials, Equipment, and Procedures for Mixing Standard Compounds and Preparing Standard Vulcanized Sheets²

D 3185 Test Methods for Rubber—Evaluation of SBR (Styrene-Butadiene Rubber) Including Mixtures with Oil²

D 3186 Test Methods for Rubber—Evaluation of SBR (Styrene-Butadiene Rubber) Mixed with Carbon Black or Carbon Black and Oil²

D 3896 Practice for Rubber from Synthetic Sources—Sampling²

D 4483 Practice for Determining Precision for Test Method Standards in the Rubber and Carbon Black Industries²

2.2 ISO Standard:³

ISO 289 Rubber, Unvulcanized—Determinations Using the Shearing Disk Viscometer,

Part 1 Determination of Mooney Viscosity, and

Part 2 Determination of Prevulcanization Characteristics.

3. Terminology

3.1 Definitions of Terms Specific to This Standard:

3.1.1 *Mooney viscosity, n*—a measure of the viscosity of a rubber or rubber compound determined in a Mooney shearing disk viscometer; viscosity is indicated by the torque required to rotate a disk embedded in a rubber specimen and enclosed in the die cavity under specified conditions.

3.1.2 *pre-vulcanization characteristics, n*— for a vulcanizable compound, a measure of the time to the incipient vulcanization and the rate of cure during the early stages of vulcanization.

¹ These test methods are under the jurisdiction of ASTM Committee D11 on Rubber and is the direct responsibility of Subcommittee D11.12 on Processability Tests.

Current edition approved Nov. 10, 2000. Published December 2000. Originally published as D 1646 – 59T. Last previous edition D 1646 – 99.

² *Annual Book of ASTM Standards*, Vol 09.01.

³ Available from American National Standards Institute, 11 W. 42nd St., 13th Floor, New York, NY 10036.

3.1.3 *stress relaxation, n*—the response of a raw or compounded rubber to a rapid cessation of flow or a sudden deformation; specific to the use of the shearing disk viscometer, it takes the form of a decaying level of stress initiated by suddenly stopping the rotation of the disk.

3.1.4 *test temperature, n*—the steady-state temperature of the closed dies with rotor in place and the cavity empty; this steady-state temperature shall be measured within the dies as described in 6.1.3.

4. Summary of Test Methods

4.1 These test methods are divided into three parts:

4.1.1 *Part A—Viscosity*: This test method describes the measurement of the Mooney viscosity. The Mooney viscosity is measured by a metal disk embedded in a rubber specimen contained in a rigid cylindrical cavity maintained at a specified pressure and temperature. The disk is slowly and continuously rotated in one direction for a specified time. The resistance to this rotation offered by the rubber is measured in arbitrary torque units as the Mooney viscosity of the specimen.

4.1.2 *Part B—Stress Relaxation*: This test method describes the procedure to measure stress relaxation. At the end of a Mooney viscosity test, the rotation of the metal disk is suddenly stopped and the rate of decrease of torque is monitored as a function of time.

4.1.3 *Part C—Pre-Vulcanization Characteristics*: This test method describes how pre-vulcanization properties may be measured. The viscosity of vulcanizable rubber compounds is recorded during heating at a specified temperature. The minimum viscosity and the times for the viscosity to increase by specified amounts are used as arbitrary measures of the start and rate of vulcanization.

5. Significance and Use

5.1 *Viscosity*—Viscosity values determined by this test method depend on molecular structure, molecular mass, and non-rubber constituents that may be present. Since rubber behaves as a non-Newtonian fluid, no simple relationship exists between the molecular mass and the viscosity. Therefore, caution must be exercised in interpreting viscosity values of rubber, particularly in cases where molecular mass is very high. For example, as the molecular mass increases, the viscosity values for IIR polymers (butyl rubbers) reach an upper limit of about 80, at 100°C (212°F) using a large rotor at a rotation speed of 2 r/min, and may then decrease to considerably lower values. For these higher molecular mass rubbers, better correlation between viscosity values and molecular mass is obtained if the test temperature is increased.

5.2 *Stress Relaxation*—The stress relaxation behavior of rubber is a combination of both an elastic and a viscous response. Viscosity and stress relaxation behavior do not depend on such factors as molecular mass and non-rubber constituents in the same way. Thus both of these tests are important and complement each other. A slow rate of relaxation indicates a higher elastic component in the overall response, while a rapid rate of relaxation indicates a higher viscous component. The rate of stress relaxation has been found to correlate with rubber structure characteristics such as molecular mass distribution, chain branching, and gel content.

5.3 *Pre-Vulcanization Characteristics*—The onset of vulcanization can be detected with this instrument as evidenced by an increase in viscosity. Therefore, this test method can be used to measure incipient cure time and the rate of cure during very early stages of vulcanization. This test method cannot be used to study complete vulcanization because the continuous rotation of the disk will result in slippage when the specimen reaches a stiff consistency.

6. Apparatus

6.1 *Mooney Viscometer*—An instrument consisting of a motor-driven rotating disk within a cylindrical die cavity formed by two dies maintained at specified conditions of temperature and die closure force. The Mooney viscometer measures the effect of temperature and time on the viscosity of rubbers. If the stress relaxation test is to be performed, the instrument must be capable of stopping the rotation of the disk and monitoring the relaxation of stress versus time. The die-rotor relationship of one design is shown in Fig. 1. The Mooney viscometer shall incorporate the following components:

6.1.1 *Dies*—The dies and die holders forming the die cavity shall be fabricated from a nondeforming tool steel, shall have an unplated finish, and shall be hardened to a Rockwell hardness of 60 HRC minimum. The dimensions of the die cavity, measured from the highest surfaces, shall be 50.93 ± 0.13 mm (2.005 ± 0.005 in.) in diameter and 10.59 ± 0.03 mm (0.417 ± 0.001 in.) in depth. The surfaces of the die cavity shall either be serrated or contain V-grooves to minimize slippage of the specimen.

NOTE 2—The two types of dies may not give the same results.

6.1.1.1 *Serrated Dies*—When the cavity is formed from four pieces of steel, serrations on the surfaces of the dies and die holders are used. These serrations consist of rectangular grooves 0.8 ± 0.02 mm (0.031 ± 0.0008 in.) wide with a uniform depth of not less than 0.25 mm (0.010 in.) nor more than 0.38 mm (0.015 in.). The grooves shall be vertical and shall be cut on 1.6 ± 0.04 mm (0.063 ± 0.002 in.) centers. The serrations of the dies shall consist of two sets of such grooves at right angles to each other.

6.1.1.2 *Radial Grooved Dies*—When the die cavity is formed from two pieces of steel, radial V-grooves are used only on the flat surfaces of the die cavity. The grooves shall be spaced at 20° intervals and shall form a 90° angle in the die surfaces with the bisector of the angle perpendicular to the surface. They shall extend from the 7-mm (0.281-in.) circle to the 47-mm (1.875-in.) circle in the upper die and from the 12-mm (0.472-in.) circle to the 47-mm circle in the lower die. The grooves shall be 1 ± 0.1 mm (0.04 ± 0.004 in.) wide at the surface.

6.1.1.3 *Mounting of Dies*—The dies shall be an integral part of or mounted on platens equipped with a heating device and controls capable of maintaining the die cavity at the specified test temperature with a tolerance of $\pm 0.5^\circ\text{C}$ ($\pm 1^\circ\text{F}$) at equilibrium conditions.

6.1.1.4 *Die Closure*—The viscometer shall have a suitable device for opening and closing the platens and dies and for holding them closed during a test. During a test it is extremely

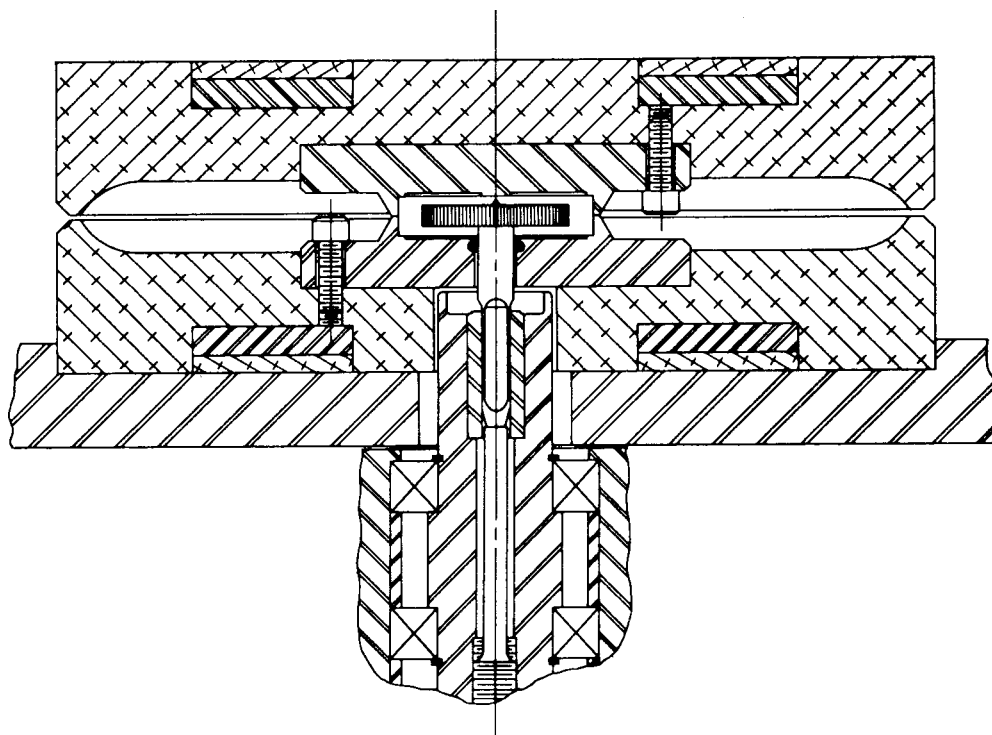

FIG. 1 Relationship of Platens, Dies, and Rotor in a Typical Shearing Disk Viscometer

important that the die cavity be held closed with the correct force. To obtain the correct closing force for the mechanical-type closures, follow explicitly either the manufacturer's recommendation or other procedure of equal reliability.⁴ Dies closed by pneumatic means shall be held closed during the actual test with a force of approximately 11.5 ± 0.5 kN (2585 ± 115 lbf). A greater force may be required to close the dies when tests are made on stocks having extreme toughness. At least 10 s before the motor is started, the force should be reduced to 11.5 ± 0.5 kN. The die closure shall be such that a piece of thin soft tissue (with a thickness not greater than 0.04 mm (0.0015 in.)) placed between the meeting surfaces will retain a continuous pattern of uniform intensity when the dies are closed upon it. A nonuniform pattern indicates wear of the die holder surface or distortion of dies and die holders. Either situation will result in undue leakage and erroneous results.

NOTE 3—For mechanical-type closure viscometers, the pressure on the die cavities may change if the viscometer is used at a different temperature than that at which it is adjusted.

6.1.2 *Rotors*—Two rotors are specified, differing only in their diameter. They shall be fabricated from a nondeforming tool steel, shall have an unplated finish and shall be hardened to a Rockwell hardness of 60 HRC minimum. The large rotor shall be 38.10 ± 0.03 mm (1.500 ± 0.001 in.) in diameter and 5.54 ± 0.03 mm (0.218 ± 0.001 in.) in thickness as measured from the highest points. The small rotor shall conform to the large rotor except the diameter shall be 30.48 ± 0.03 mm (1.200 ± 0.001 in.). The serrations on the face of the rotor shall

conform to the requirements for the serrated dies given in 6.1.1.1 and the serrations on the edge of the rotor shall conform to the requirements specified for the serrated die holders. The rotor head shall be securely mounted perpendicularly to a suitable straight cylindrical stem not exceeding 11 mm (0.433 in.) in diameter. The rotor head shall be positioned so that the top and bottom surfaces are 2.54 ± 0.10 mm (0.100 ± 0.005 in.) from the surfaces of the top and bottom dies, respectively, when the dies are closed. The wear tolerance from the center position should not exceed ± 0.25 mm (± 0.010 in.). A suitable seal shall be provided in the lower die having a minimum clearance and constant torque when the machine is run empty. The eccentricity, or runout, shall not exceed 0.1 mm.

6.1.2.1 *Rotor wear* will affect test results. Any rotor worn to such an extent that the rotor diameter is less than the minimum diameter shown in this procedure shall not be used.

6.1.2.2 *Rotor Drive*—The disk shall be rotated relative to the dies at a rotational rate of 0.21 rad/s (2.0 r/min), unless otherwise specified. The permissible tolerance shall be ± 0.002 rad/s (± 0.02 r/min).

6.1.2.3 *Rotor Stop*—If the stress relaxation test is to be performed, the instrument shall be capable of stopping the rotor within 0.1 s.

6.1.3 *Temperature Measuring System*—Since the measurement of the temperature of the rubber in the die cavity is difficult and impractical, the temperature of the closed dies shall be measured with the rotor in place and the cavity empty. The temperature measuring system shall consist of platinum resistance temperature sensors, thermocouples, or thermistors. Calibrated platinum resistance temperature sensors capable of indicating the temperature to within $\pm 0.25^\circ\text{C}$ ($\pm 0.5^\circ\text{F}$) are preferred. When calibrated thermocouples (copper-constantan,

⁴ Decker, G. E., "Note on the Adjustment of the Mooney Viscometer Die Closure," *ASTM Bulletin*, No. 195, January 1954, p. 51.

Type T0.25 mm, or 30 wire gage are suggested) or thermistors are used, they shall be capable of indicating the temperature to at least $\pm 0.5^{\circ}\text{C}$ ($\pm 1^{\circ}\text{F}$). A temperature sensor shall be located in each die for control of the die temperature. The active element of the sensor shall be 3 to 5 mm (0.12 to 0.20 in.) from the surface of the die and 15 to 20 mm (0.6 to 0.8 in.) from the rotor axis.

6.1.4 *Torque Measuring System*—The torque measuring system shall be designed to measure zero torque when the rotor is turning in an empty cavity, and to measure 100 ± 0.5 Mooney units when a torque of 8.30 ± 0.02 N·m (73.5 ± 0.2 lbf·in.) is applied to the rotor shaft. If the stress relaxation test is to be performed, the torque measuring system must reset to a zero force for a stationary rotor. The torque measuring system shall record the torque during the relaxation test at minimum rates of one reading each second for the first 6 s after the rotor is stopped, one reading each 3 s for the next 24 s, one reading each 6 s for the next 30 s, and one reading each 12 s for the remainder of the relaxation test.

6.2 *Mill*—A laboratory rubber mill conforming to the requirements in Practice D 3182 and set as described in 7.2 of this test method shall be used to prepare massed samples.

7. Sample Preparation

7.1 Condition the sample obtained in accordance with Test Methods D 1485 or Practice D 3896 until it has reached room temperature ($23 \pm 3^{\circ}\text{C}$ ($73 \pm 5^{\circ}\text{F}$)) throughout.

7.2 The sample may be tested as received, unmassed, or it may be massed. Better repeatability within labs and reproducibility between labs is normally obtained on unmassed specimens. However, the sample may be massed to expel air, to consolidate particles, or to modify it, if necessary. When mill massing is required use the sample preparation steps shown in 7.2 and as specified in Table 1 for the type of rubber being tested. When specimens cannot be easily cut from the unmassed material and mill massing is not appropriate, the manufacturer of the material should be asked to recommend an alternate sample preparation procedure. For best reproducibility of results, minimum work (shear) should be done to the

material during specimen preparation.

7.2.1 Pass 250 ± 5 g of the sample between the rolls of the standard laboratory mill as described in Practice D 3182 having a roll temperature of $70 \pm 5^{\circ}\text{C}$ ($158 \pm 9^{\circ}\text{F}$) and having a distance between the rolls of 2.5 ± 0.1 mm (0.1 ± 0.005 in.) as determined by a lead slug. Roll the specimen and immediately insert it endwise in the mill for another pass. Repeat this procedure until a total of ten passes have been completed. Sheet the specimen on the tenth pass.

7.2.2 Pass 250 ± 5 g of the sample between the rolls of the standard laboratory mill as described in Practice D 3182 having a roll temperature of $50 \pm 5^{\circ}\text{C}$ ($122 \pm 9^{\circ}\text{F}$) and having a distance between the rolls of 1.4 ± 0.1 mm (0.055 ± 0.005 in.) as determined by a lead slug. Immediately fold the specimen in half and insert the folded end into the mill for a second pass. Repeat this procedure until a total of nine passes have been completed. Immediately insert the rubber without folding into the mill for a tenth pass. Do not allow the specimen to rest between passes or to band on the mill rolls at any time.

7.2.3 Pass 250 ± 5 g of the sample between the rolls of the standard laboratory mill as described in Practice D 3182 having a roll temperature of $50 \pm 5^{\circ}\text{C}$ ($122 \pm 9^{\circ}\text{F}$) and having a distance between the rolls of 1.4 ± 0.1 mm (0.055 ± 0.005 in.) as determined by a lead slug. Immediately fold the specimen in half and inserted the folded end into the mill for a second pass. Repeat this procedure until a total of nine passes have been completed. Open the mill rolls to 3 ± 0.1 mm (0.125 ± 0.005 in.), fold the specimen in half and pass it between the rolls once. Do not allow the specimen to rest between passes or to band on the mill rolls at any time.

7.3 *Unmassed Specimen*—Prepare an unmassed sample by cutting a piece of rubber approximately 60 by 150 by 10 mm (2 by 6 by 0.375 in.) from which the specimen can be cut. This piece should be cut in a way that will minimize work on the sample.

7.4 *Pre-Vulcanization Characteristics Sample*—Prepare compounded stock as described in the test method for the type

TABLE 1 Standard Viscosity Test Conditions

Type Rubber ^A	Sample Preparation, See Section	Test Temperature, °C ^B	Running Time, min ^C
IRM 241	7.1 and 7.3	100 ± 0.5 or 125 ± 0.5	8.0
Unmassed sample	7.1 and 7.3	Use conditions listed below for type rubber being tested.	
NR	7.1 and 7.2.1	100 ± 0.5	4.0
BR	7.1 and 7.2.2	100 ± 0.5	4.0
CR			
IR			
NBR			
SBR			
BIIR	7.1 and 7.2.2 ^D	100 ± 0.5 or $125 \pm 0.5^{\text{E}}$	8.0
CIIR			
IIR			
EPDM	7.1 and 7.2.2	125 ± 0.5	4.0
EPM			
Synthetic rubber black masterbatch	7.1 and 7.2.3	100 ± 0.5	4.0
Compounded stock reclaimed material	7.1 and 7.3	100 ± 0.5	4.0
Miscellaneous	If similar to any group above, test accordingly. If not, establish a procedure.		

^A See Practice D 1418.

^B Test temperatures are $100 \pm 0.5^{\circ}\text{C}$ ($212 \pm 1^{\circ}\text{F}$) or $125 \pm 0.5^{\circ}\text{C}$ ($257 \pm 1^{\circ}\text{F}$).

^C Time after the standard 1.0-min warm-up period at which the viscosity measurement is made.

^D If no air bubbles are visible in the sample, 7.2.2 may be omitted.

^E Use a temperature of $125 \pm 0.5^{\circ}\text{C}$ ($257 \pm 1^{\circ}\text{F}$) whenever specimen has a viscosity higher than 60-ML 1 + 8(100°C).

rubber being tested or another agreed-upon recipe or procedure.

8. Test Specimen

8.1 *Conditioning*—Condition unmassed specimens until they have attained room temperature ($23 \pm 3^\circ\text{C}$ ($73 \pm 5^\circ\text{F}$)) throughout. Allow massed specimens to rest at room temperature for at least 30 min before measuring their viscosity.

8.2 *Preparation*—The test specimen shall consist of two pieces of the material being tested having a combined volume of $25 \pm 3 \text{ cm}^3$. This volume is approximately 1.5 times the volume of the test cavity (1.45 times for small rotor, 1.67 times for large rotor) and will ensure that the cavity is filled completely. For convenience the mass of the test specimen of correct volume may be calculated as follows:

$$m = v \times d = 25 \text{ cm}^3 \times d \quad (1)$$

where:

m = mass, g,

v = volume in $\text{cm}^3 = 25 \text{ cm}^3$, and

d = density in Mg/m^3 (g/cm^3).

NOTE 4— Mg/m^3 and g/cm^3 are numerically equivalent.

Test specimen mass shall be within a tolerance of $\pm 3 \text{ g}$. The pieces shall be cut from the prepared specimen and shall be of such dimensions that they will fit within the die cavity without projecting outside it before the viscometer is closed. A45-mm (1.75-in.) diameter cutting die may be used to assist in preparing the test pieces. A hole punched in the center of one of the test pieces facilitates the centering of the disk stem. It shall not be permissible to slip the test piece around the rotor stem by cutting it edgewise. When testing low viscosity or sticky materials, it is permissible to insert between the specimen and die cavity a layer of film approximately 0.025 mm (0.001 in.) thick. The film selected should not react with the test specimen. Materials that have been found suitable include cellophane,⁵ polyester,⁶ high-density polyethylene (at 100°C only), and similar materials. The test specimen shall be as free of air and volatile materials as it is practical to make it and shall be free of pockets which may trap gasses against the rotor or die surfaces.

8.3 Because the value of viscosity obtained for a given specimen will vary depending on the manner in which the specimen is prepared and the conditions of rest prior to the test, it is imperative that specimen preparation be made in strict accordance with this procedure or some mutually agreed upon procedure if comparisons of results are to be made.

9. Calibration

9.1 The shearing disk viscometer shall be calibrated any time its results are suspected of being inaccurate, after any repairs, before any interlaboratory test program, before testing disputed specimens, and frequently enough to ensure the maintenance of proper calibration of the instrument.

⁵ Flexel 128 PUT uncoated cellophane, available from Flexel, Inc., 115 Perimeter Center Place, Suite 1100, Atlanta, GA 30346 has been found satisfactory for this purpose.

⁶ Mylar 100A, available from Cadillac Plastic and Chemical Co., 530 Stephenson Hwy., Troy, MI 48002-6035, has been found satisfactory for this purpose.

9.2 The shearing disk viscometer shall be calibrated while the machine is running at the temperature at which it is normally used. The viscometer shall be adjusted so that it will read zero torque when run empty and 100 ± 0.5 when a torque of $8.30 \pm 0.02 \text{ N}\cdot\text{m}$ ($73.5 \pm 0.2 \text{ lbf}\cdot\text{in.}$) is applied to the rotor shaft. Therefore, a torque of $0.083 \text{ N}\cdot\text{m}$ ($0.735 \text{ lbf}\cdot\text{in.}$) is equivalent to one Mooney unit.

NOTE 5—It is recommended that ASTM Industrial Reference Material, IRM 241, butyl rubber, be used for routine checking of the operation of the viscometer. The use of this or any other reference rubber shall not be used as a substitute for mechanical calibration as described in this section of the standard.

PART A—MEASURING MOONEY VISCOSITY

10. Procedure

10.1 Select the rotor to be used for the test. The large rotor should be used unless the Mooney viscosity would exceed the capacity of the instrument, or when slippage occurs or is suspected. However, when slippage occurs with the large rotor, changing to the small rotor may not prevent it.

10.2 Adjust the temperature of the closed dies with the rotor in place to the temperature shown in Table 1 for the type of rubber being tested. The temperature of the two dies shall be within 0.5°C (1°F) of each other. Unless otherwise specified the temperature for viscosity determination shall be $100 \pm 0.5^\circ\text{C}$ ($212 \pm 1^\circ\text{F}$).

10.3 Adjust the torque indicator to the zero reading while the viscometer is running in the unloaded condition with the rotor in place. Then stop the rotation of the disk. This adjustment should be made with the dies open for machines with rotor ejection springs (so the rotor does not rub against the upper die), but with the dies closed for all other types of machines.

NOTE 6—If the viscometer has a seal between the rotor stem and the die, frequent zero adjustment may be necessary because of a change in friction between the rotor stem and the seal.

10.4 Remove the hot rotor from the properly conditioned cavity, quickly insert the stem through the center of one of the test pieces, and replace in the viscometer. Place the second piece on the center of the rotor, close the dies and immediately activate the timer.

NOTE 7—A brass pry rod with a flattened end should be used for removing the rotor to prevent damaging it or the dies.

10.5 Warm the specimen in the closed cavity of the Mooney viscometer for exactly 1 min and then start the motor which drives the rotor. Experimental polymers or especially tough materials may require a longer warm-up time.

10.6 It is recommended that a recorder be used to continuously record viscosity readings for the time shown in Table 1 for the type of rubber being tested. When a recorder is not used, observe the dial indicator or digital display continuously during the 30-s interval preceding the specified time of reading. Take as the viscosity the minimum value to the nearest whole unit during this interval. The running time should never be less than 2 min.

NOTE 8—The temperature gradients and rate of heat transfer will differ somewhat from one machine to another, particularly if different types of

heating are employed. Therefore, it may be expected that the viscosity values obtained for a rubber tested on different machines will be more comparable if taken after temperature equilibrium of the specimen is attained. Usually this condition is reached about 10 min after the machine is closed on the specimen. For most rubbers, the viscosity value obtained will not be altered appreciably by permitting the specimen to warm in the machine for different times, provided that the viscosity is read at a specified time.

11. Report

11.1 The report on the viscosity test shall include the following:

11.1.1 Sample identification,

11.1.2 Method of specimen preparation: U = unmassed, M = massed, and C = compounded.

11.1.3 Mooney viscosity number to the nearest whole unit,

11.1.3.1 The Mooney viscosity number shall be reported as measured. Values obtained with one rotor shall not be converted to equivalent values for the other rotor since the relationship between rotors may vary depending on the type of rubber and test conditions. If an exact relationship is required, it should be established for each rubber and set of test conditions.

11.1.4 Rotor size (*L* = large, *S* = small),

11.1.5 Time that the test specimen was permitted to warm in the machine before starting the motor, min,

11.1.6 Time at which the viscosity reading was taken after starting the motor, min,

11.1.7 Test temperature,

11.1.8 Rotor speed if other than 0.20 rad/s (2.0 r/min),

11.1.9 Type of film used, if any, and

11.1.10 Make and model of instrument used.

NOTE 9—Example: Results of a typical test would be reported as follows:

50 – UML 1 + 4(100°C)
using polyethylene film and
a Monsanto MV2000 instrument

Where 50– is the viscosity number, U indicates an unmassed specimen, M indicates Mooney, L indicates the use of the larger rotor (*S* would indicate the small rotor), 1 is the time in minutes that the specimen was permitted to warm in the machine before starting the motor, 4 is the time in minutes after starting the motor at which the reading is taken, and 100°C is the temperature of test.

PART B—MEASURING STRESS RELAXATION

12. Procedure

12.1 If the stress relaxation test is to be performed, it must follow a viscosity test as described in 10.

12.2 At the end of the viscosity test, stop the rotation of the disk within 0.1 s, reset the zero torque point to the static zero for a stationary rotor, and record the torque at minimum rates as listed in 6.1.4. The relaxation data shall be collected starting typically 1 s after the rotor is stopped, and continuing for at least 1 min and typically for 2 min after the rotor is stopped. A typical chart from a Mooney viscosity test followed by a stress relaxation test is shown in Fig. 2.

NOTE 10—Resetting torque to a static zero is necessary because the dynamic zero used for the viscosity test would result in a negative torque value once the material had completely relaxed with a stationary disk. The relaxation of torque for most polymers is so rapid that stopping the rotor,

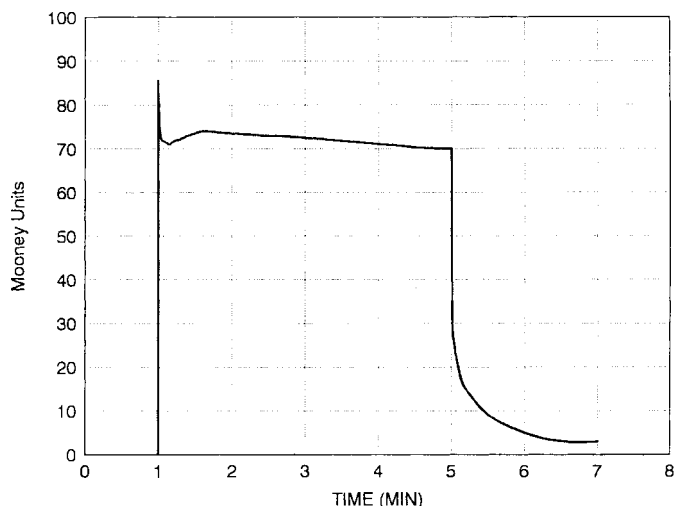

FIG. 2 Example Torque Curve from a Mooney Viscosity Test Plus a Stress Relaxation Test

resetting zero and recording the relaxing torque must be controlled automatically.

12.3 Analysis of Stress Relaxation Data:

12.3.1 Analysis of stress relaxation data (torque versus time data) consists of (1) developing a plot of torque (Mooney units) versus time (s); this normally takes the form of a log-log plot as shown in Fig. 3, and (2) calculating the constants of the power law model of material response, as represented by Eq 2.

$$M = k(t)^a \quad (2)$$

where:

M = Mooney units (torque) during the stress relaxation test,

k = a constant equal to the torque in Mooney units 1 s after the disk is stopped, and

a = an exponent that determines the rate of stress relaxation.

12.3.2 If Eq 2 is transformed by taking the log of both sides, Eq 3 is obtained:

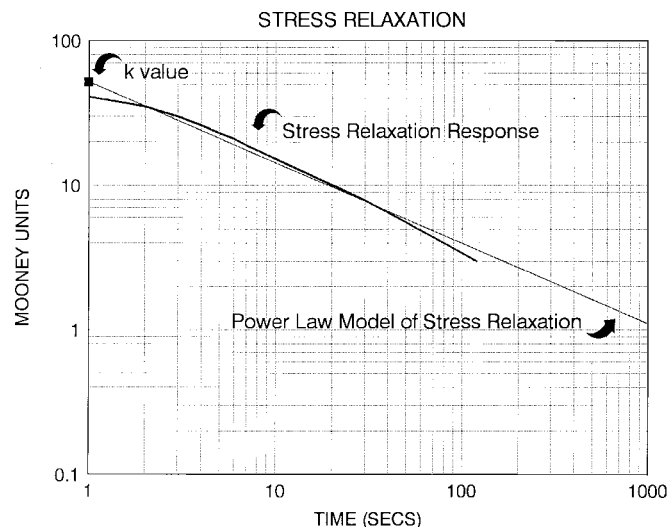

FIG. 3 Plot of Log Mooney Units Versus Log Time from a Stress Relaxation Test

$$\log M = a(\log t) + \log k \quad (3)$$

This has the form of a linear regression equation where a equals the slope, $\log k$ equals the intercept and $\log M$ and $\log t$ correspond respectively to the dependent and independent variables. In a plot of $\log M$ versus $\log t$, as shown in Fig. 3, the slope of the graph, $(\log M/\log t)$, is equal to a . The correlation coefficient, r , from the regression equation should also be calculated.

12.3.3 The area under the stress relaxation curve from the beginning time (t_o) to the end of the stress relaxation test (t_f) may also be calculated using Eq 4:

$$A = \frac{k}{(a+1)} [t_f^{(a+1)} - t_o^{(a+1)}] \quad (a \neq -1.000) \quad (4)$$

where:

A = area under the relaxation curve from (t_o) to the end of (t_f) the stress relaxation test (Mooney units-seconds), and

t_o = beginning time of the stress relaxation test, s, and

t_f = total time of the stress relaxation test, s.

12.3.3.1 If the slope $a = -1.000$, then Eq 4 should be changed to Eq 5:

$$A = k[1n(t_f/t_o)] \quad (a = -1.000) \quad (5)$$

13. Report

13.1 The report for a stress relaxation test shall contain the following information:

13.1.1 The full report of the viscosity test of Part A,

13.1.2 Duration of the stress relaxation test, s,

13.1.3 One or more of the following data points from the stress relaxation curve:

13.1.3.1 Time, s, from disk stop to x % decay of the Mooney viscosity, t_x ,

13.1.3.2 Percent decay of the Mooney viscosity at y seconds after disk stop, X_y %,

13.1.3.3 The value of the exponent a , the constant k and the correlation coefficient r from the calculation of a power law model of the stress relaxation.

13.1.3.4 The value of A , (M-s), area under the stress relaxation curve power law model for a time span from 1 s to t_f , time of the end of the stress relaxation test.

NOTE 11—Example: Results of a typical stress relaxation test would be reported as follows:

50 = ML 1 + 4(100°C) + 120 s SR

t_{80} = 16.0 s of stress relaxation to decay by 80 % of Mooney viscosity

X_{30} = 86.1 % decay of Mooney viscosity at 30 s from disk stop

Power Law Decay Model:

k = 48.0

a = -0.5805

r = 0.9946

A = 738 M-s

PART C—MEASURING PRE-VULCANIZATION CHARACTERISTICS

14. Procedure

14.1 Adjust the temperature of the closed dies with rotor in place to the desired test temperature. The recommended test temperatures are those specified in Practice D 1349 from 70°C

(158°F) upward. Other temperatures may be used if desired. An optimum test temperature for vulcanizable compounds will yield the required increase of Mooney units within a period of 10 to 20 min.

14.2 Adjust the torque indicator to the zero reading while the closed viscometer is running in the unloaded condition with the rotor in place and the proper operating pressure. Then stop the rotation of the disk (Note 6).

14.3 Remove the hot rotor from the properly conditioned cavity, quickly insert the stem through the center of one of the test pieces and replace the viscometer. Place the second test piece on the center of the rotor, close the dies immediately, and activate the timer (Note 7).

14.4 Warm the specimen in the closed cavity of the Mooney machine for exactly 1 min and then start the motor which drives the rotor.

14.5 Measure the time from the instant the dies are closed, and start the rotor 1 min later unless otherwise specified. Either record the viscosity continuously or take sufficient readings to permit the preparation of a complete time-viscosity curve (example shown in Fig. 4). Record the following information:

14.5.1 Minimum viscosity.

14.5.2 The time required for a specified increase above the minimum viscosity. When the small rotor is used this increase is 3 units and the time is designated t_3 . When the large rotor is used the increase is 5 units and the time is designated t_5 .

14.5.3 The time required for a specified larger increase above the minimum viscosity. When the small rotor is used the increase is 18 units and the time is designated t_{18} . When the large rotor is used the increase is 35 units and the time is designated t_{35} .

14.5.4 Cure index as follows:

For small rotor

$$\Delta t_S = t_{18} - t_3 \quad (6)$$

For large rotor

$$\Delta t_L = t_{35} - t_5 \quad (7)$$

15. Report

15.1 The report for the pre-vulcanization characteristics shall include the following (for referee purposes the entire viscosity-time curve shall be provided):

15.1.1 Sample and specimen identification,

15.1.2 Test temperature,

15.1.3 Rotor size,

15.1.4 Minimum viscosity,

15.1.5 t_3 or t_5 ,

15.1.6 t_{18} or t_{35} ,

15.1.7 Cure index, and

15.1.8 Make and model of instrument used.

NOTE 12—A low value for the cure index indicates a fast rate-of-cure. A high value for the cure index would correspondingly indicate a slow rate-of-cure. The curing characteristics reported in 14.1.5.2, 14.1.5.3 and 14.1.5.4 may differ appreciably when determinations are made on the same compound using the large and small rotors.

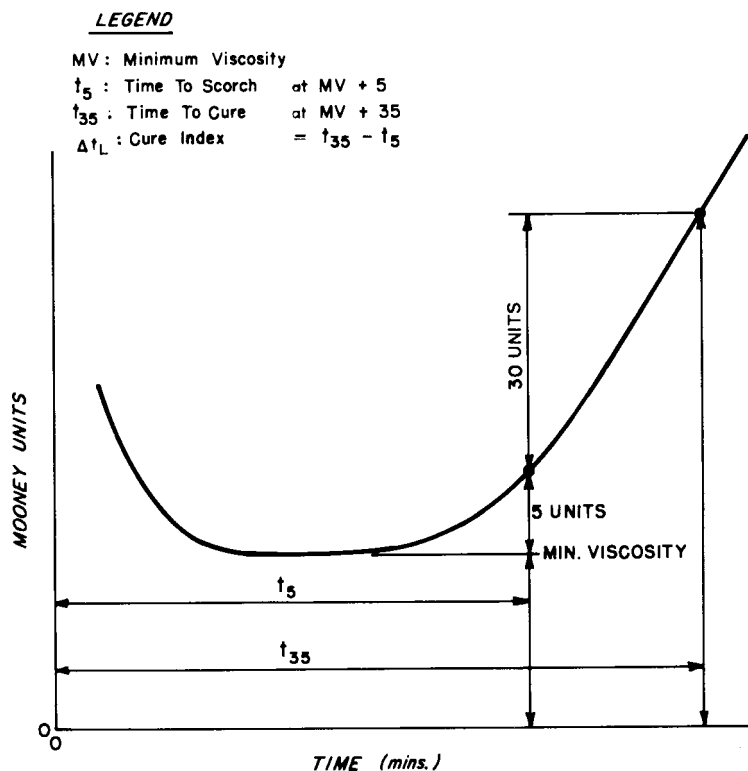

FIG. 4 Typical Prevulcanization Characteristics Curve Using Large Rotor

16. Precision and Bias ⁷

16.1 This precision and bias section has been prepared in accordance with Practice D 4483. Refer to Practice D 4483 for terminology and other statistical details.

16.2 The results in this precision and bias section give an estimate of the precision of this test method with the materials used for the precision evaluation. These precision parameters should not be used for acceptance or rejection testing of any group of materials without documentation that they are applicable to those particular materials and the specific testing protocols of the test method.

16.3 The precision of this test method may be expressed in the format of the following statements which use what is called an appropriate value of r , R , (r) or (R), that is associated with a material or mean level in the precision tables in routine testing operations.

16.3.1 *Repeatability*— Two single test results, obtained in the same laboratory under normal test method procedures, that differ by more than the appropriate tabulated value of r (for any given level) must be considered as derived from different or non-identical sample populations.

16.3.2 *Reproducibility*— Two single test results obtained in two different laboratories under normal test method procedures, that differ by more than the appropriate tabulated value of R (for any given level) must be considered to have come from different or non-identical sample populations.

16.3.3 Repeatability and reproducibility expressed as a percentage of the mean level, designated as (r) and (R), have

equivalent application statements as above for r and R . For the (r) and (R), statements, the difference in the two single test results is expressed as a percentage of the arithmetic mean of the two results.

16.4 Table 2 lists details of the precision testing programs for this precision and bias statement. Mooney viscosity test precision was compared for samples prepared with and without mill massing. Viscosity interlaboratory precision testing was conducted at two different times; Program 1 in the first half of 1989, and Program 2 in the second half of 1989. Both programs evaluated a Type 1 precision which does not require detailed processing compounding, or other extensive operations on the test samples in any individual laboratory.

16.4.1 The precision is described as a Type 1 although in some cases pretest milling operations were performed according to section 7 of this test method.

16.4.2 For Program 1, 15 laboratories participated in Mooney viscosity testing using 7 different rubbers (materials) on each of two days, tested both with and without mill massing.

16.4.3 For program 2, 12 laboratories participated in Mooney viscosity testing using three different rubbers (materials) on each of two days, tested both with and without mill massing.

16.4.4 IRM 24lb was tested by 21 laboratories in 1997 as part of its qualification as an IRM. Test results at both 125°C and 100°C are reported in Table 3.

16.5 Stress relaxation interlaboratory testing to estimate precision was conducted as Program 3 in 1996. This was a Type 1 precision program; all samples were presented by a single laboratory, and tested without mill massing.

16.5.1 For Program 3, 10 laboratories participated in stress

⁷ Supporting data are available from ASTM Headquarters. Request RR:D11-1045.



TABLE 2 Details on Rubbers and Compounds for Precision Testing Programs

Rubber or Material		Programs 1 and 2—Rubbers for Mooney Viscosity Precision Testing Description	Test Temperature, °C	Other Details
1	IIR (Butyl), IRM 241bn		100	ML-1 + 8
2	TSR-20, Technically Specified Natural Rubber		100	ML-1 +4
3	BR 220, Butadiene Rubber		100	ML-1 +4
4	NBR-CLT, Acrylonitrile-Butadiene Rubber		100	ML-1 +4
5	SBR 1712, Oil-extended SBR		100	ML-1 +4
6	CR-S3, Chloroprene rubber		100	ML-1 +4
7	EPDM 538, EPDM Terpolymer		125	ML-1 +4
8	EPDM 6505, EPDM Terpolymer		125	ML-1 +4
9	SBR 1848, Black and Oil-extended SBR		100	ML-1 +4
10	SBR 1815, Black and Oil-extended SBR		100	ML-1 +4

Rubber or Material		Program 3—Rubbers for Mooney Stress Relaxation Precision Testing Description	Test Temperature, °C	Other Details
1	IIR (Butyl), IRM 241a		100	ML-1 + 8, 2m SR
2	SMR L, Natural Rubber		100	ML-1 + 4, 2m SR
3	SBR 1500, SRM 386j		100	ML-1 + 4, 2m SR
4	EPDM 7006, EPDM Terpolymer		125	ML-1 + 4, 2m SR
5	EPDM 70A, EPDM Terpolymer		125	ML-1 + 4, 2m SR

Rubber or Material		Program 4—Rubber Compounds for Mooney Pre-Vulcanization Characteristics Precision Testing Description	Test Temperature, °C	Rotor Size
1	SBR 1505, D 3185 Formulation, Mill Mixed		150	Small
2	SBR 1500, D 3185 Formulation, Mill Mixed		150	Small
3	SBR 1849, D 3186 Formulation, Mill Mixed		150	Large
4	SBR 3651, D 3186 Formulation, Mill Mixed		150	Large

TABLE 3 Type 1 Mooney Viscosity Precision for Clear Rubbers

Part A—Samples Prepared Without Mill Massing ^A								
Material	Mean Level	Within Laboratories ^B			Between Laboratories ^B			
		S _r	r	(r)	S _R	R	(R)	
BR-220	41.0	0.244	0.691	1.69	0.785	2.222	5.42	
SBR 1712	44.8	0.731	2.067	4.61	1.043	2.950	6.58	
CR-S3 ^A	54.3	0.664	1.880	3.46	1.045	2.958	5.45	
EPDM 6505	53.0	0.358	1.012	1.91	1.449	4.100	7.73	
NBR-CLT	66.6	0.618	1.748	2.62	1.362	3.854	5.78	
EPDM 538 ^A	71.3	0.838	2.370	3.31	1.447	4.096	5.73	
TSR-20 (NR)	96.0	0.769	2.176	2.27	1.136	3.214	3.35	
Pooled (Average) Values	61.0	0.637	1.802	2.95	1.448	4.098	6.72	
IIR (IRM 241b), ML-1 +8@125°C	49.8	0.546	1.545	3.10	0.921	2.606	5.23	
IIR (IRM 241b), ML-1 +8@100°C	72.5	0.637	1.803	2.49	1.493	4.225	5.83	

Part B—Samples Prepared With Mill Massing								
Material	Mean Level	Within Laboratories ^B			Between Laboratories ^B			
		S _r	r	(r)	S _R	R	(R)	
BR-220	40.3	0.338	0.955	2.37	0.701	1.983	4.92	
SBR 1712	47.4	1.135	3.212	6.77	1.925	5.447	11.49	
CR-S3	48.8	1.377	3.897	7.97	2.257	6.387	13.06	
EPDM 6505	51.4	0.611	1.729	3.37	1.647	4.662	9.07	
NBR-CLT	67.0	0.768	2.174	3.26	1.853	5.244	7.87	
EPDM-538	70.9	1.493	4.224	6.15	2.275	6.437	9.37	
TSR-20 (NR)	91.3	1.193	3.375	3.79	1.909	5.403	6.07	
Pooled (Average) Values	59.6	1.063	3.009	5.05	1.862	5.268	8.84	

^AThe unmilled CR (Chloroprene) rubber test sample was formed by layering pieces of rubber above and below the rotor.
The unmilled EPDM 538 (a friable crumb rubber) test sample was formed by compacting the rubber in a press heated to 100°C for 5 minutes before cutting.

^B S_r = repeatability standard deviation.
r = repeatability = 2.83 × (Square root of the repeatability variance)
(r) = repeatability (as percentage of material average)
S_R = reproducibility standard deviation.
R = reproducibility = 2.83 × (Square root of the reproducibility variance)
(R) = reproducibility (as percentage of material average)

relaxation testing immediately after Mooney viscosity testing using 5 rubbers (materials) on each of two days.

16.6 Mooney pre-vulcanization characteristics interlab precision testing was conducted as Program 4 in 1982. This was a Type 1 precision program; all compounds were prepared for testing by a single laboratory using the procedures in test

methods D 3185 and D 3186.

16.7 The precision and bias results for Part A (Viscosity), Part B (Stress Relaxation) and Part C (Pre-Vulcanization Characteristics) are given in this section of the standard. Table 3 and Table 4 contain the results for Part A, Table 5 contains



TABLE 4 Type 1 Mooney Viscosity Precision for Black Masterbatch Rubbers

		Part A—Samples Prepared Without Mill Massing			Between Laboratories ^A		
Material	Mean Level	Within Laboratories ^A			S _R	R	(R)
		S _r	r	(r)			
SBR 1848	120.8	2.268	6.419	5.31	5.178	14.652	12.13
SBR 1815	98.6	1.171	3.312	3.36	2.534	7.170	7.27
		Part B—Samples Prepared With Mill Massing			Between Laboratories ^A		
Material	Mean Level	Within Laboratories ^A			S _R	R	(R)
		S _r	r	(r)			
SBR 1848	74.6	2.791	7.897	10.59	5.433	15.376	20.61
SBR 1815	61.0	1.667	4.718	7.74	4.169	11.797	19.34

^A S_r = repeatability standard deviation.
r = repeatability = 2.83 × (Square root of the repeatability variance)
(r) = repeatability (as percentage of material average)
S_R = reproducibility standard deviation.
R = reproducibility = 2.83 × (Square root of the reproducibility variance)
(R) = reproducibility (as percentage of material average)

TABLE 5 Type 1 Mooney Stress Relaxation Precision

Material	Mean Level	Within Laboratories ^A			Between Laboratories ^A		
		S _r	r	(r)	S _R	R	(R)
Part A—Stress Relaxation Slope, (Mooney Units/minute)							
SMR L (NR)	-0.1810	0.0059	0.0168	9.28	0.0114	0.032	17.79
SBR 1500 (SRM 386j)	-0.3582	0.0042	0.0120	3.35	0.0143	0.041	11.36
IIR (IRM 241a Butyl)	-0.5081	0.0067	0.0189	3.72	0.0178	0.050	9.92
EPDM 70A	-0.5385	0.0098	0.0280	5.29	0.0370	0.105	19.52
EPDM 7006	-0.9561	0.0680	0.1940	20.29	0.2060	0.584	61.00
Part B—Stress Relaxation Intercept, (Mooney Units)							
SMR L (NR)	69.97	0.749	2.120	3.03	2.849	8.060	11.53
SBR 1500 (SRM 386j)	31.70	1.192	3.370	10.63	1.630	4.620	14.55
IIR (IRM 241a Butyl)	56.02	0.855	2.240	4.32	1.608	4.560	8.12
EPDM 70A	29.21	0.758	2.150	7.36	1.410	3.980	13.66
EPDM 7006	18.36	1.640	4.630	25.22	3.326	9.410	51.23

^A S_r = repeatability standard deviation.
r = repeatability = 2.83 × (Square root of the repeatability variance)
(r) = repeatability (as percentage of material average)
S_R = reproducibility standard deviation.
R = reproducibility = 2.83 × (Square root of the reproducibility variance)
(R) = reproducibility (as percentage of material average)

the results for Part B and Table 6 contains the results for Part C.

TABLE 6 Type 1 Mooney Pre-Vulcanization Characteristics Precision

Material	Test Features	Mean Level	Within Laboratories ^A			Between Laboratories ^A		
			S _r	r	(r)	S _R	R	(R)
Part A—Minimum Viscosity, (Mooney units)								
SBR 1505	small rotor	21.6	0.346	0.979	4.53	0.931	2.635	12.20
SBR 1500	small rotor	25.2	0.282	0.798	3.17	0.934	2.643	10.49
SBR 1849	large rotor	27.1	0.460	1.302	4.80	0.803	2.725	10.06
SBR 3651	large rotor	37.7	0.547	1.548	4.11	1.065	3.014	7.99
Pooled (Average) Values		27.9	0.421	1.192	4.27	0.938	2.654	9.51
Part B—Scorch Time, (minutes)								
SBR 1505	small rotor, t ₃	8.1	0.177	0.501	6.18	0.821	2.323	28.68
SBR 1500	small rotor, t ₃	8.2	0.221	0.625	7.63	0.983	2.782	33.93
SBR 3651	large rotor, t ₅	8.2	0.289	0.818	9.97	0.967	2.737	33.37
SBR 1849	large rotor, t ₅	9.2	0.220	0.623	6.77	0.898	2.540	27.62
Pooled (Average) Values		8.43	0.230	0.652	7.73	0.920	2.602	30.87
Part C—Cure Index, (minutes)								
SBR 1505	small rotor, t ₁₈ -t ₃	1.98	0.088	0.249	12.58	0.145	0.410	20.72
SBR 3651	large rotor, t ₃₅ -t ₅	2.29	0.073	0.206	8.97	0.207	0.586	25.58
SBR 1849	large rotor, t ₃₅ -t ₅	2.56	0.190	0.538	21.02	0.364	1.030	40.24
SBR 1500	small rotor, t ₁₈ -t ₃	2.63	0.122	0.345	13.13	0.249	0.705	26.79
Pooled (Average) Values		2.37	0.127	0.359	15.16	0.254	0.719	30.35

^A S_r = repeatability standard deviation.
r = repeatability = 2.83 × (Square root of the repeatability variance)
(r) = repeatability (as percentage of material average)
S_R = reproducibility standard deviation.
R = reproducibility = 2.83 × (Square root of the reproducibility variance)
(R) = reproducibility (as percentage of material average)

 **D 1646**

16.7.1 For Program 4, 11 laboratories participated in pre-vulcanization characteristics testing using four rubber compounds (materials) on each of two days.

16.8 For all of the test programs, a test result is the test value from one measurement or determination with the Mooney viscometer.

16.9 *Mooney Viscosity Precision for Clear (Non-Pigmented) Rubbers*—Table 3 lists the repeatability and reproducibility results (as well as the respective standard deviations) for the clear rubbers. For all but the lowest viscosity material (BR-220), the precision for unmassed specimens is better than for mill massed specimens. Both r and R vary with material type. Precision expressed as a percentage of the mean, (r) and (R), was essentially independent of viscosity level.

16.10 *Mooney Viscosity Precision for Black Masterbatch Rubbers*—Table 4 lists the repeatability and reproducibility results (as well as the respective standard deviations) for two black masterbatch rubbers. For these materials, the precision for unmassed specimens is better than for mill massed specimens. Both r and R vary with material type. The precision expressed as a percentage of the mean, (r) and (R), was essentially independent of viscosity level.

16.11 *Mooney Stress Relaxation Precision for Raw Rubbers and Rubber Compounds*—Table 5 lists the repeatability and reproducibility results (as well as the respective standard deviations) for the tested rubbers. Both r and R vary with material type. The precision expressed as as percentage of the

mean, (r) and (R), was highest for materials with the fastest decay rates (high negative slope values) and the lowest stress relaxation intercept values.

16.12 *Mooney Pre-Vulcanization Characteristics Precision:*

16.12.1 For Mooney pre-vulcanization characteristics testing, four compounds were prepared for testing as outlined in Table 2. This table also shows details on the formulation and rotor size used for the testing. All pre-vulcanization characteristics testing was done at 150°C (302°F).

16.12.2 Table 6 lists the repeatability and reproducibility results (as well as the respective standard deviations) for the Mooney pre-vulcanization characteristics test results of minimum viscosity, scorch time and cure index. Over the range of parameter values (levels) there is a general increase in r and R as the mean level increases. No pronounced increase in (r) and (R), is evident.

16.13 *Bias*—In test method terminology, bias is the difference between an average test value and the reference (or true) test property value. Reference values do not exist for this test method since the value (of the test property) is exclusively defined by the test method. Bias, therefore, cannot be determined.

17. Keywords

17.1 curing characteristics; Mooney; stress relaxation; viscosity; vulcanization characteristics

**NOTICE: This standard has either been superseded and replaced by a new version or discontinued.
Contact ASTM International (www.astm.org) for the latest information.**



The American Society for Testing and Materials takes no position respecting the validity of any patent rights asserted in connection with any item mentioned in this standard. Users of this standard are expressly advised that determination of the validity of any such patent rights, and the risk of infringement of such rights, are entirely their own responsibility.

This standard is subject to revision at any time by the responsible technical committee and must be reviewed every five years and if not revised, either reapproved or withdrawn. Your comments are invited either for revision of this standard or for additional standards and should be addressed to ASTM Headquarters. Your comments will receive careful consideration at a meeting of the responsible technical committee, which you may attend. If you feel that your comments have not received a fair hearing you should make your views known to the ASTM Committee on Standards, at the address shown below.

This standard is copyrighted by ASTM, 100 Barr Harbor Drive, PO Box C700, West Conshohocken, PA 19428-2959, United States. Individual reprints (single or multiple copies) of this standard may be obtained by contacting ASTM at the above address or at 610-832-9585 (phone), 610-832-9555 (fax), or service@astm.org (e-mail); or through the ASTM website (www.astm.org).