



Standard Practice for Rubber—Materials, Equipment, and Procedures for Mixing Standard Compounds and Preparing Standard Vulcanized Sheets¹

This standard is issued under the fixed designation D 3182; the number immediately following the designation indicates the year of original adoption or, in the case of revision, the year of last revision. A number in parentheses indicates the year of last reapproval. A superscript epsilon (ε) indicates an editorial change since the last revision or reapproval.

This standard has been approved for use by agencies of the Department of Defense.

1. Scope

1.1 This practice provides a listing of reference compounding materials required to prepare the rubber test compounds listed in succeeding methods and contains procedures for weighing. It also specifies the mixing equipment, general mixing procedures, vulcanization equipment and procedures.

1.2 The values stated in SI units are to be regarded as the standard. The values given in parentheses are for information only.

1.3 *This standard does not purport to address all of the safety concerns, if any, associated with its use. It is the responsibility of the user of this standard to establish appropriate safety and health practices and determine the applicability of regulatory limitations prior to use. For specific precaution statements, see 5.5.*

2. Referenced Documents

2.1 ASTM Standards:

- D 88 Test Method for Saybolt Viscosity²
- D 1646 Test Method for Rubber—Viscosity, Stress Relaxation, and Pre-Vulcanization Characteristics (Mooney Viscometer)³
- D 2084 Test Method for Rubber Property—Vulcanization Using Oscillating Disk Cure Meter³
- D 2161 Practice for Conversion of Kinematic Viscosity to Saybolt Universal Viscosity or to Saybolt Furol Viscosity⁴
- D 2226 Classification for Various Types of Petroleum Oils for Rubber Compounding Use³
- D 2501 Test Method for Calculation of Viscosity-Gravity Constant (VGC) of Petroleum Oils⁴
- D 4678 Practice for Rubber—Preparation, Testing, Acceptance, Documentation, and Use of Reference Materials³

E 145 Specification for Gravity-Convection and Forced-Ventilation Ovens⁵

3. Significance and Use

3.1 This practice shall be used for specific procedures used in preparing rubber compounds for quality control of production, for research and development purposes, and for comparison of different materials.

4. Standard Materials

4.1 Standard Reference Materials:

4.1.1 The materials required for standard rubber test formulas shall be National Institute of Standards and Technology (NIST) Reference Materials or materials that are known to have properties similar to these standard materials. However, in case of dispute, the following actual standard materials from the NIST of the United States shall be used:

4.1.2 An Industry Reference Material (IRM) is a standard reference from a designated supplier and has been certified in accordance with Practice D 4678.^{6,7}

NIST Standard Reference Material or IRM	Standard Reference Material No.	Industry Reference Material No.
Zinc oxide	370	
Sulfur	371	
Stearic acid	372	
Benzothiazyl disulfide ⁶		2
Tetramethylthiuram disulfide ^{6,7}		1
Magnesium oxide	376	
Oil furnace carbon black—HAF	378	
Gas furnace carbon black—SRF	382	
Mercaptobenzothiazole	383	
<i>N-tert-butyl-2-benzothiazolesulfenamide</i>	384	
SBR-1500	386	
Natural rubber ⁸	201	

¹ This practice is under the jurisdiction of ASTM Committee D11 on Rubber and is the direct responsibility of Subcommittee D11.20 on Compounding Materials and Procedures.

Current edition approved Mar. 31, 1989. Published May 1989. Originally published as D 3182 – 73. Last previous edition D 3182 – 87.

² *Annual Book of ASTM Standards*, Vol 04.04.

³ *Annual Book of ASTM Standards*, Vol 09.01.

⁴ *Annual Book of ASTM Standards*, Vol 05.01.

⁵ *Annual Book of ASTM Standards*, Vol 14.04.

⁶ NIST has discontinued supply of SRM 373, 374, and 385. A substitute material is available as IRM 2, 1, and 201 respectively from Forcoven Products, Inc., P.O. Box 1556, Humble, TX 77338 for IRM 1 and 2. IRM 201 is available from Akron Chemical Co., 255 Fountain St., Akron, OH 44304. Request RR: D11-1034, available from ASTM International Headquarters.

⁷ Supporting data are available from ASTM International Headquarters. Request RR: D11-1026.

4.2 Other standard or industry reference materials are as follows: Industry Reference Black Current Lot in use at time of testing ASTM Oil Type 103⁸

5. Weighing of Materials

5.1 The standard batch mass (in grams) for the laboratory mill shall be three times the formula mass in parts per hundred grams of rubber, unless otherwise specified.

5.2 The batch mass (in grams) for an internal mixer shall be the nominal capacity ($1170 \pm 40 \text{ cm}^3$) multiplied by the density of the rubber compound.

5.3 The batch mass (in grams) for a miniature internal mixer (MIM) shall be 75 % of the nominal capacity ($85 \pm 1 \text{ cm}^3$) multiplied by the density of the rubber compound.

5.4 The rubber and carbon black shall be weighed to within a tolerance of $\pm 1 \text{ g}$ for mill and internal mixer compounds and with a tolerance of $\pm 0.1 \text{ g}$ for miniature internal mixer compounds. All other materials shall be weighed with a $\pm 0.1\text{-g}$ accuracy or less for mill and internal mixer compounds and with $\pm 0.01\text{-g}$ accuracy for the miniature internal mixer compounds.

5.5 Compounding materials other than rubber, carbon black, and oil may be added to miniature internal mixer batches more precisely and with greater ease if they are previously blended in proportion to the mass required by the recipe. Such blend may be made in a mortar and pestle, by mixing for 10 min in a biconical blender with intensifier bar turning, or by mixing in a blender⁹ for five 3-s periods and scraping the inside of the mixer to dislodge materials stuck to the sides after each 3-s mix. (**Warning**—If mixed longer than 3 s, the stearic acid may melt and prevent good dispersion.)

5.6 Unless otherwise specified, carbon black shall be conditioned by heating for 1 h at $125 \pm 3^\circ\text{C}$ ($257 \pm 5^\circ\text{F}$) in a 1 B oven or equivalent, in accordance with Specification E 145.

5.6.1 Place the carbon black in an open vessel of suitable dimensions so that the depth of the black is no more than 10 mm (0.4 in.) during conditioning. Store the conditioned carbon black in a closed moisture-proof container until cool and then use for weighing and mixing.

6. Equipment for Mixing

6.1 Standard Mill:

6.1.1 The standard mill shall have rolls between 150 and 155 mm (5.9 and 6.1 in.) in diameter. The mill shall be equipped with retaining guides, with a distance between the guides at the nip of 250 to 280 mm (10 to 11 in.).

NOTE 1—If mills of other sizes are used, adjustments to batch masses and mixing cycles may be required to obtain equivalent results.

⁸ Defined by Classification D 2226. A lot of oil conforming to the basic description in Classification D 2226 and more specifically, to the values listed below, can be obtained from Sun Refining and Marketing Co., Process Materials Group, 10 Penn Center, 1801 Market St., Philadelphia, PA 19103 (available in 1 and 5-gal quantities): Kinematic Viscosity (Test Method D 88) and (Practice D 2161) $16.8 \pm 1.2 \text{ mm}^2/\text{s}$ at 100°F , Viscosity-Gravity Constant (Test Method D 2501) 0.889 ± 0.002 .

⁹ A Waring Blender has been used in this practice. Results cannot be guaranteed using another brand.

6.1.2 The speed of the slow roll shall be $0.4 \pm 0.50 \text{ rad/s}$ ($24 \pm 0.5 \text{ rpm}$) and the ratio between slow and fast roll shall be 1:1.4. Other ratios may be used, but modifications in mixing procedure may be required to obtain equivalent results. The use of other than a standard mill shall be recorded with the reported data.

6.1.3 Means shall be provided for controlling the mill roll temperatures to the specified temperature $\pm 5^\circ\text{C}$ ($\pm 9^\circ\text{F}$).

6.1.4 The clearance between rolls shall be adjustable from 0.2 to 8.0 mm (0.008 to 0.31 in.) as a minimum range of adjustment. Roll clearance shall be determined by means of two lead strips $10 \pm 3 \text{ mm}$ ($0.4 \pm 0.1 \text{ in.}$) wide, at least 50 mm (2 in.) long, and 0.25 to 0.50 mm (0.01 to 0.02 in.) thicker than the roll clearance to be measured. The lead strips shall be inserted, one at each end of the rolls approximately 25 mm (1 in.) from the guides, while a piece of compounded rubber, with Mooney viscosity in excess of 50 ML 1 + 4 at 100°C (212°F), approximately 75 by 75 by 6 mm (3 by 3 by 0.25 in.) is passing through the center portion of the rolls. The rolls shall be at the temperature specified for mixing. After the lead strips have passed through the rolls, measure the thickness of the strips to the nearest 0.02 mm (0.001 in.). Tolerance on a roll clearance shall be $\pm 10 \%$ or 0.05 mm (0.002 in.), whichever is larger.

6.2 *Standard Internal Mixer*—The standard internal mixer shall have a chamber of $1575 \pm 50 \text{ cm}^3$ volume and two rotors with approximately 400-cm^3 displacement volume, resulting in $1170 \pm 40\text{-cm}^3$ loading capacity. The slow rotor speed shall be 8.16 rad/s (77 rpm) and the gear ratio shall be 1:1.125. The rotor wing tip to side clearance shall be $2.4 + 0.3, - 0.1 \text{ mm}$ ($0.094 + 0.010, - 0.005 \text{ in.}$). The mixer shall be equipped with a thermocouple for measuring and recording batch mixing temperatures. The thermocouple shall be installed through the end frame and shall protrude into the mixing chamber $25 \pm 2.5 \text{ mm}$ ($1 \pm 0.1 \text{ in.}$) measured along the top side of the thermocouple probe. A ram that is $56 \pm 3 \text{ mm}$ by $140 \pm 8 \text{ mm}$ ($2.2 \pm 0.1 \text{ in.}$ by $5.5 \pm 0.3 \text{ in.}$) shall exert a force of $1.27 \pm 0.06 \text{ kN}$ ($285 \pm 14 \text{ lbf}$) on the batch in the chamber. The sides shall be hinged to swing open, made of cast stainless steel and jacketed for controlling temperature by means of a circulating liquid or steam. The end frames shall be of ductile iron that has a $0.20 \pm 0.02\text{-mm}$ ($0.008 \pm 0.001\text{-in.}$) thick chrome plating on the working surfaces. Rotors are of stainless steel, nitrided, drilled, and equipped with rotary unions for controlling the rotor temperature by means of a circulating liquid or steam.

NOTE 2—If internal mixers of other sizes are used, adjustments of batch masses and rotor speeds or mixing cycles will be required to obtain equivalent results.

6.3 Standard Miniature Internal Mixer (MIM):

6.3.1 The standard miniature internal mixer shall be equipped with a stainless steel mixer head having a bowl of 120-cm^3 volume and stainless steel cam-style mixer rotors (removable or fixed) of 34 to 35-cm^3 displacement, thus resulting in a $85 \pm 1\text{-cm}^3$ volume. The recommended loading is 75 % (64 cm^3). The fast or driving rotor (left) shall turn at $6.28 + 3.14 \text{ rad/s}$ ($60 + 3, - 0 \text{ rpm}$) and the gear ratio (drive to driven) shall be 1.5:1. The mixer shall be equipped with a thermocouple installed through the ridge in the bowl for measuring and recording the batch temperatures. The mixing

chamber shall be closed during the mixing cycle by means of a lever or ram. The head and the backplate shall be maintained at the required temperature either electrically or by means of a thermal liquid medium.

NOTE 3—If miniature internal mixers equipped with Banbury-style mixer head and rotors or heads of other sizes are used, adjustments of batch masses, rotor speeds, or mixing cycles will be required to obtain equivalent results.

6.3.2 The miniature internal mixer may be equipped with a torque-measuring instrument and recorder, which are not essential for the mixing operation. If used, it must be calibrated occasionally and after each overhaul of the miniature internal mixer using the manufacturer's instructions.

7. General Mixing Procedures

7.1 Mill Mixing Procedure:

7.1.1 Mix compounds with the rubber banded on the slow roll, unless otherwise specified.

7.1.2 Measure the temperature of the surfaces of the rolls at a point approximately equidistant from the ends during the mixing operation either continuously on a recorder or with a manual device having an accuracy of at least $\pm 1^{\circ}\text{C}$ ($\pm 2^{\circ}\text{F}$), frequently enough to maintain the desired temperature. The batch may be removed momentarily from the mill to measure the surface temperature of the slow roll.

7.1.3 Whenever $\frac{3}{4}$ cuts are specified, cut the batch $\frac{3}{4}$ of the distance across the roll and hold the knife at this position until the bank just disappears. Make successive $\frac{3}{4}$ cuts from alternate ends of the roll, allowing 20 s between each cut unless otherwise specified.

7.1.4 Do not cut any batch while free materials are evident in the bank or on the milling surface.

7.1.5 Add carbon black evenly across the mill at a uniform rate. Add all other dry materials slowly and evenly in prescribed times. Oil, if required, may be added alternately with carbon black. Carefully collect materials falling through the nip from the tray and return to the mix.

7.1.6 Conclude the mixing cycle by passing the rolled batch endwise through the mill six times with an opening of 0.8 mm (0.031 in.), to improve the dispersion.

7.1.7 Pass the batch four times through the mill at a setting of 6 mm (.25 in.), folding it back on itself each time.

7.1.8 Weigh the batch, remove the test specimens for Mooney viscosity in accordance with Test Method D 1646 or cure meter in accordance with Test Method D 2084, or both, and sheet out the remainder to 2.2 to 2.4-mm (0.087 to 0.094-in.) thickness after shrinkage has taken place.

7.2 Internal Mixer Mixing Procedure:

7.2.1 The compound is usually prepared in two stages: the first one always in the internal mixer and the second either in the internal mixer or on the standard mill.

7.2.2 The initial internal mixer temperature will be either indicated or be such that the required discharge temperature is reached.

7.2.3 The rotor speed shall be 8.16 rad/s (77 rpm), unless otherwise specified.

7.2.4 Cut the rubber into pieces suitable for fast feeding.

7.2.5 Prepare the mix according to specified instructions regarding the order and time of material addition.

7.2.6 Consolidate the discharge on a standard mill, weigh, and allow to cool on a flat metal surface before proceeding with the second-stage mix.

7.2.7 If the second stage mix is prepared in the internal mixer, cut the batch from stage 1 into strips for easier feeding, and follow by the addition of the materials according to the specific instructions. The batch should then be discharged at the prescribed time or temperature. If the second-stage mix is prepared on the standard mill, add materials in prescribed order and time. The batch size may be reduced to better accommodate the mill and to result in better dispersion of compounding materials.

7.2.8 Conclude the mixing by passing the rolled batch endwise through the standard mill six times with an opening of 0.8 mm (0.031 in.), to improve the dispersion.

7.2.9 Pass the batch four times through the mill at a setting of 6 mm (0.24 in.), folding it back on itself each time.

7.2.10 After weighing and removal of test specimens, sheet out the batch to 2.2 to 2.4-mm (0.087 to 0.094-in.) thickness after shrinkage has taken place.

7.3 Miniature Internal Mixer Procedure:

7.3.1 Maintain the mixer head temperature for at least 5 min before mixing.

7.3.2 The unloaded rotor speed shall be $1.0 + 0.05, - 0$ rev/s ($60 + 3, - 0$ rpm), unless otherwise specified. It should be frequently checked if a variable speed model is used.

7.3.3 Prepare the compound according to instructions specified for the rubber.

7.3.4 Immediately pass the discharge from the mixer twice through a standard mill maintained at specified temperature with roll separation of 0.5 mm (0.020 in.) once, then twice at a separation of 3 mm (0.12 in.), in order to dissipate the heat, and weigh.

7.3.5 After the removal of a curemeter specimen, if a compound viscosity or tension specimen, or both are required, pass the batch endwise through the mill six times with an opening of 0.8 mm (0.031 in.) to enhance the dispersion.

7.3.6 After removing the compound viscosity specimen, if a tension specimen is required, pass the batch four times through a standard mill at specified temperature. Fold it lengthwise after each pass and pass always in the same direction to obtain the effect of mill direction. The roll opening should be such that it will produce a 2.2 to 2.4-mm (0.087 to 0.094-in.) thick sheet after shrinkage.

8. Preparation of Standard Vulcanized Sheets

8.1 Preparation of Sheets:

8.1.1 Unless otherwise specified, condition the sheeted compound for 1 to 24 h at $23 \pm 3^{\circ}\text{C}$ ($73.4 \pm 5.4^{\circ}\text{F}$) at a relative humidity not greater than 55 %. For maximum precision, condition for 1 to 24 h in a closed container to prevent absorption of moisture from the air, or in an area controlled at 35 ± 5 % relative humidity.

8.1.2 Place the sheeted compound on a flat, dry, clean metal surface and cut pieces that are 4.5 ± 1.5 mm (0.18 ± 0.06 in.)

shorter in width and length than the corresponding dimensions of the mold cavity. Mark the direction of the milling on each piece.

8.1.3 The mass of a 150 by 150-mm (6 by 6-in.) sheet or a 150 by 75-mm (6 by 3-in.) sheet to be vulcanized in the molds described in 8.2.2 shall be as shown below:

Density of Compound	Mass of Unvulcanized Sheet, g	
	150 by 150 mm (6 by 6 in.)	150 by 75 mm (6 by 3.0 in.)
0.94	52 ± 3	26 ± 1.5
0.96	53	27
0.98	54	27
1.00	55	28
1.02	56	28
1.04	57	29
1.06	58	29
1.08	59	30
1.10	60	30
1.12	61	31
1.14	62	31
1.16	63	32
1.18	64	32
1.20	65	33
1.22	66	33
1.24	67	34
1.26	68	34
1.28	69	35
1.30	70	35

8.1.4 A film of suitable material, such as a nonlubricated aluminum foil 0.1 mm (0.004 in.) thick, may be placed above and below the sheet in the mold to prevent contamination with materials remaining in the mold from previous cures. The mass of the unvulcanized sheet shall be reduced to compensate for the thickness of the foil.

8.2 Vulcanization Equipment:

8.2.1 *Press*—The press shall be capable of exerting a pressure of not less than 3.5 MPa (500 psi) on the total cross-sectional area of the cavities of the mold during the entire period of vulcanization. It shall have heated platens of sufficient size so that no portion of the rubber will be nearer than 75 mm (3 in.) to the edge of the platen during vulcanization. The platen shall preferably be made of rolled steel, machined for steam heating or for electrical elements for heating electrically. When steam heat is used, place either a self-bleeding trap or a small vent in the exit stream line to allow steam to flow continuously through the platens. If chamber-type platens are used, place the steam outlet slightly below the steam chamber so that good drainage is assured. Reduce conduction of heat from the hot platens to the press cross-head as much as practicable by means of a steel grid between them, or by other means. Platens should be suitably shielded from drafts. The pressing surfaces of the platen shall be plane parallel to within 0.25 mm/m (0.003 in./ft) when the platens are at 150°C (302°F) and closed under full pressure with a grid of soft solder or lead between them. With either type of platen, the temperature over the mold area shall be uniform. The maximum deviation from the temperature at the center of the platen shall not exceed ±0.5°C (1°F). Between adjacent platens the temperature difference between corresponding points on the two platens shall not exceed 0.5°C (1°F).

8.2.2 Molds:

8.2.2.1 The mold for 150 by 150 by 2-mm (6 by 6 by 0.08-in.) sheets shall have cavity sections similar in dimensions to that shown in Fig. 1. The cavities to within 6.3 mm (0.25 in.) of the edges shall be between 1.9 and 2.0 mm (0.075 and 0.079 in.) deep. The corners of the cavities may be rounded with a radius not greater than 6.3 mm (0.25 in.). An alternative type of test sheet mold, made by the cut-off bar method with a lower plate thickness of about 20 mm (0.75 in.), is shown in Fig. 2.

8.2.2.2 The mold for 150 by 75 by 2-mm (6 by 3.0 by 0.08-in.) sheets shall have cavity sections similar in dimensions to that shown in Fig. 3 or Fig. 4. The cavities of this mold shall meet the requirements described in 8.2.2.1.

8.2.2.3 The molding surfaces shall be cleaned, highly polished, and hard chromium-plated. Molds constructed of hardened steel are preferred, but chrome-plated mild steel and stainless steel are also acceptable. The cover of the mold shall be a flat plate at least 10 mm (0.4 in.) in thickness and preferably hinged to the cavity section to minimize scratching of the mold surfaces. Instead of a separate mold and cover, the cavities may be cut directly into the platen of the press. Unless required, do not use a mold lubricant on the mold surfaces. When a mold lubricant is required, use only a residual-type lubricant, which does not affect the vulcanized sheet, and remove the excess lubricant by vulcanizing and discarding at least one set of sheets. A silicone-type lubricant or mild soap solution has been found satisfactory.

8.3 Vulcanization Procedure:

8.3.1 Bring the mold to curing temperature within ±0.5°C (1°F) in the closed press, and hold at this temperature for at least 20 min before the unvulcanized pieces are inserted. Verify the temperature of the mold by means of a thermocouple or other suitable temperature measuring device inserted in one of the overflow grooves and in intimate contact with the mold.

8.3.2 Open the press, insert the unvulcanized pieces into the mold, and close the press in the minimum time possible. When the mold is removed from the press to insert the pieces, take precautions to prevent excessive cooling of the mold by contact with cool metal surfaces or by exposure to air drafts.

8.3.3 Consider the time of vulcanization to be the period between the instant the pressure is applied fully and the instant the pressure is released. Hold the mold under a minimum pressure of 3.5 MPa (500 psi) on the cavity areas during vulcanization. As soon as the press is opened, remove the vulcanized sheets from the mold and cool in water (room temperature or lower) or on a metal surface (for items used for electrical measurements) for 10 to 15 min. Designate in the report the type of cooling used.

8.3.4 Condition vulcanizates of compounds at a temperature of 23 ± 2°C (73 ± 3.6°F) for at least 16 h (Note 4) and for not more than 96 h before preparing and testing, unless otherwise specified.

NOTE 4—Quality control of rubber production may require testing within 1 to 6 h to provide close surveillance of the plant operation; however, slightly different results may be obtained.

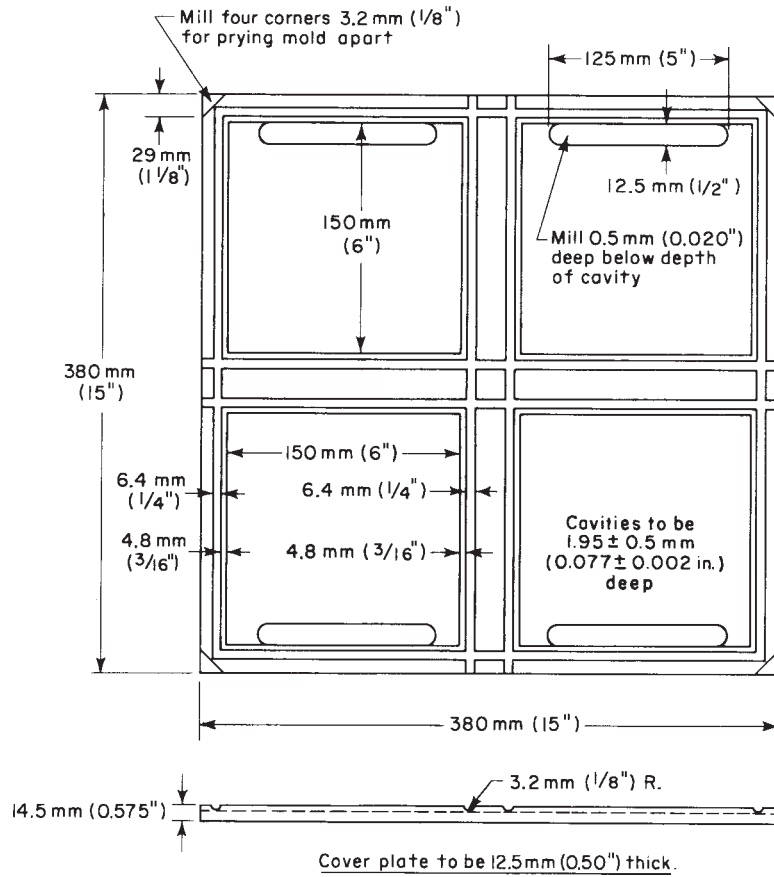

FIG. 1 Design of Four-Cavity Mold

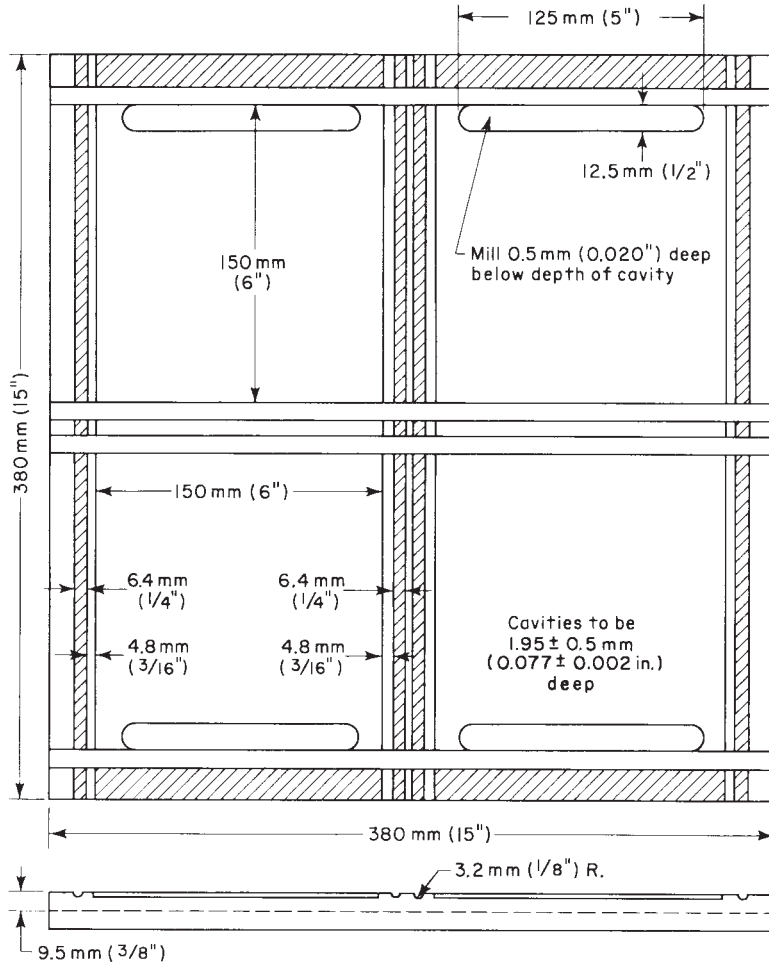
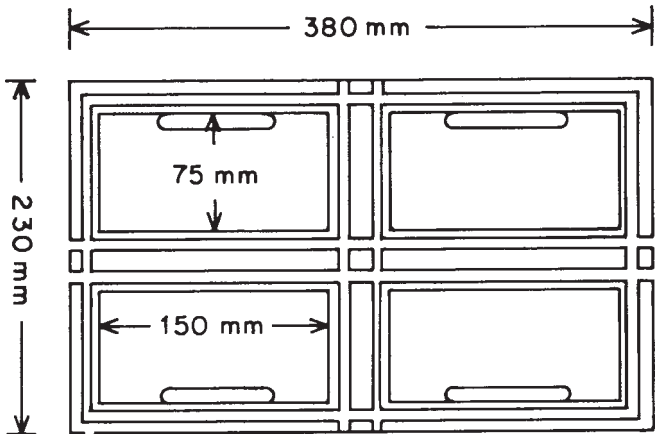

FIG. 2 Cutoff Bar Type of Test of Slab Mold



NOTE 1—All other dimensions as in Fig. 1.

FIG. 3 Design for Four Cavity Small Tensile Sheet Mold

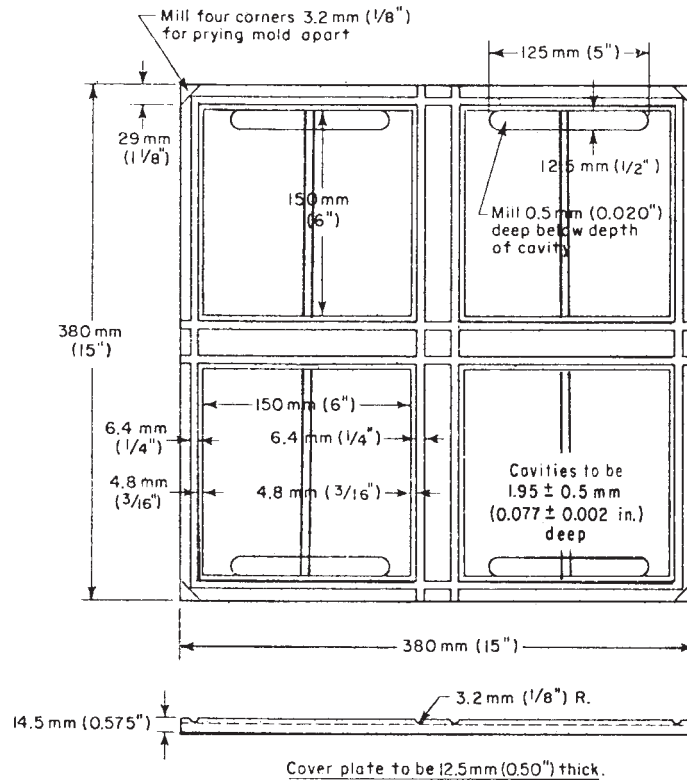

FIG. 4 Design of Eight Cavity Mold, for Small Tensile Sheets Made by Modifying the Mold Shown in Fig. 1

ASTM International takes no position respecting the validity of any patent rights asserted in connection with any item mentioned in this standard. Users of this standard are expressly advised that determination of the validity of any such patent rights, and the risk of infringement of such rights, are entirely their own responsibility.

This standard is subject to revision at any time by the responsible technical committee and must be reviewed every five years and if not revised, either reapproved or withdrawn. Your comments are invited either for revision of this standard or for additional standards and should be addressed to ASTM International Headquarters. Your comments will receive careful consideration at a meeting of the responsible technical committee, which you may attend. If you feel that your comments have not received a fair hearing you should make your views known to the ASTM Committee on Standards, at the address shown below.

This standard is copyrighted by ASTM International, 100 Barr Harbor Drive, PO Box C700, West Conshohocken, PA 19428-2959, United States. Individual reprints (single or multiple copies) of this standard may be obtained by contacting ASTM at the above address or at 610-832-9585 (phone), 610-832-9555 (fax), or service@astm.org (e-mail); or through the ASTM website (www.astm.org).