



Standard Practice for Rubber—Measurement of Dimensions¹

This standard is issued under the fixed designation D 3767; the number immediately following the designation indicates the year of original adoption or, in the case of revision, the year of last revision. A number in parentheses indicates the year of last reappraisal. A superscript epsilon (ϵ) indicates an editorial change since the last revision or reappraisal.

This standard has been approved for use by agencies of the Department of Defense.

1. Scope

1.1 This practice is intended for use in determining the geometrical dimensions of rubber products and specimens for physical tests. This practice describes procedures for determining length, width, thickness, diameter, and circumference. This practice does not cover sampling of materials or products, or locations where a sample is to be taken.

1.2 The values stated in either acceptable metric units or in other units shall be regarded separately as a standard. The values stated in each system may not be exact equivalents; therefore, each system must be used independently of the other, without combining values in any other way.

1.3 *This standard does not purport to address all of the safety problems, if any, associated with its use. It is the responsibility of the user of this standard to establish appropriate safety and health practices and determine the applicability or regulatory limitations prior to use.*

2. Referenced Documents

2.1 ASTM Standards:

D 1415 Test Method for Rubber Property—International Hardness²

D 3183 Practice for Rubber—Preparation of Pieces for Test Purposes From Products²

3. Summary of Practice

3.1 Specific procedures are outlined depending upon size, texture, and shape of the test specimens undergoing measurement.

3.1.1 Procedure A encompasses linear dimensions up to 30 mm using a flat-footed micrometer on flat sheets and test specimens.

3.1.2 Procedure encompasses thickness dimensions up to 30 mm using a micrometer with contact members that are domed surfaces. This procedure is employed on irregularly shaped test specimens and compression set test specimens.

3.1.3 Procedure encompasses thickness measurements of flexible cellular test specimens up to 30 mm using a micrometer with large area flat contact members.

¹ This practice is under the jurisdiction of ASTM Committee D-11 on Rubber and is the direct responsibility of Subcommittee D11.10 on Physical Testing.

Current edition approved Nov. 10, 1996. Published December 1996. Originally published as D 3767 – 79. Last previous edition D 3767 – 84 (1992).

² *Annual Book of ASTM Standards*, Vol 09.01.

3.1.4 Procedure B encompasses linear dimensions between 30 and 100 mm using a vernier caliper.

3.1.5 Procedure C encompasses linear dimensions above 100 mm using a tape or linear scale.

3.1.6 Procedure D encompasses thickness measurements on soft thin materials using a microscope.

3.1.7 Procedure E encompasses circumference measurements by cone.

4. Significance and Use

4.1 Dimensional measurements specified in this practice are made for one of the following purposes: (1) to determine conformance with specification requirements regarding geometrical properties of whole units, such as the size of rubber gloves, or the diameter and circumference of rubber hose, (2) to determine conformance with specification requirements regarding particular functional parts of units, such as the thickness of the soles of boots, or (3) to determine geometrical values that are necessary in the calculation of test results for physical properties for which requirements are specified, such as the thickness of a test specimen for tensile strength. The method to be used shall be as specified in the detail specification or appropriate test method.

4.2 Pressure applied by measuring instruments has a significant effect on the observed thickness of soft flexible materials, and it is therefore necessary to specify the pressure imposed by the foot of the instrument on the test piece for accurate comparative measurements of such materials.

5. Test Specimens

5.1 Test specimens shall consist of a product, in whole or in part, for which the geometric dimensions are sought, as described in a detail specification or test method. Material, as referenced herein, shall be interpreted as the substance(s) of which a product is comprised.

6. Number of Measurements

6.1 Unless otherwise specified in the detail specification or test method, three measurements shall be made on each test specimen or product and the median value taken.

7. Buffing

7.1 If the test specimen has uneven surfaces, such as fabric impression or corrugations that may interfere with the test, for

example, on the tube or cover of hose, the material may be buffed lightly so that the surface is smooth and of uniform thickness. Buffing shall be performed in accordance with the sections on Buffing Techniques, Abrasive Wheels, and Abrasive Flexible Bands in Practice D 3183.

8. Conditioning

8.1 Unless otherwise specified in the detail specifications or test method, geometrical measurements shall be made after conditioning test specimens for 24 h at $23 \pm 5^\circ\text{C}$ ($73.4 \pm 9^\circ\text{F}$). If Procedure D (see Section 12) is used, the relative humidity of $50 \pm 5\%$ at $23 \pm 2^\circ\text{C}$ ($73.4 \pm 3.6^\circ\text{F}$) should be maintained.

PROCEDURES

9. Procedures A, A1, and A2 (Dimensions of 30 mm or Less)

9.1 Procedure A:

9.1.1 *Scope*—Dimensions of length, width, Scopethickness, and diameters of test specimens less than 30 mm (1.2 in.) shall be measured with a micrometer instrument.

9.1.2 *Apparatus*—The apparatus shall consist of the following parts (an example of suitable apparatus is shown in Fig. 1 and Fig. 2):

9.1.2.1 *Anvil*, at least 35 mm (1.4 in.) in diameter, that is attached to a rigid base plate.

(1) *Flat Rigid Base Plate*, at least 140 mm (5.5 in.) in diameter, that is attached to a rigid frame.

(2) *Solid Platform Base* (see Fig. 2), granite at least 5 by 5 in. square and 1.75 in. in height. The top surface is ground flat and perpendicular to the guide post and micrometer assembly, at the operating height, to a tolerance of ± 0.002 in.

9.1.2.2 *Micrometer* (such as a dial or digital-electronic), capable of measuring dimensions to an accuracy within 1 % of

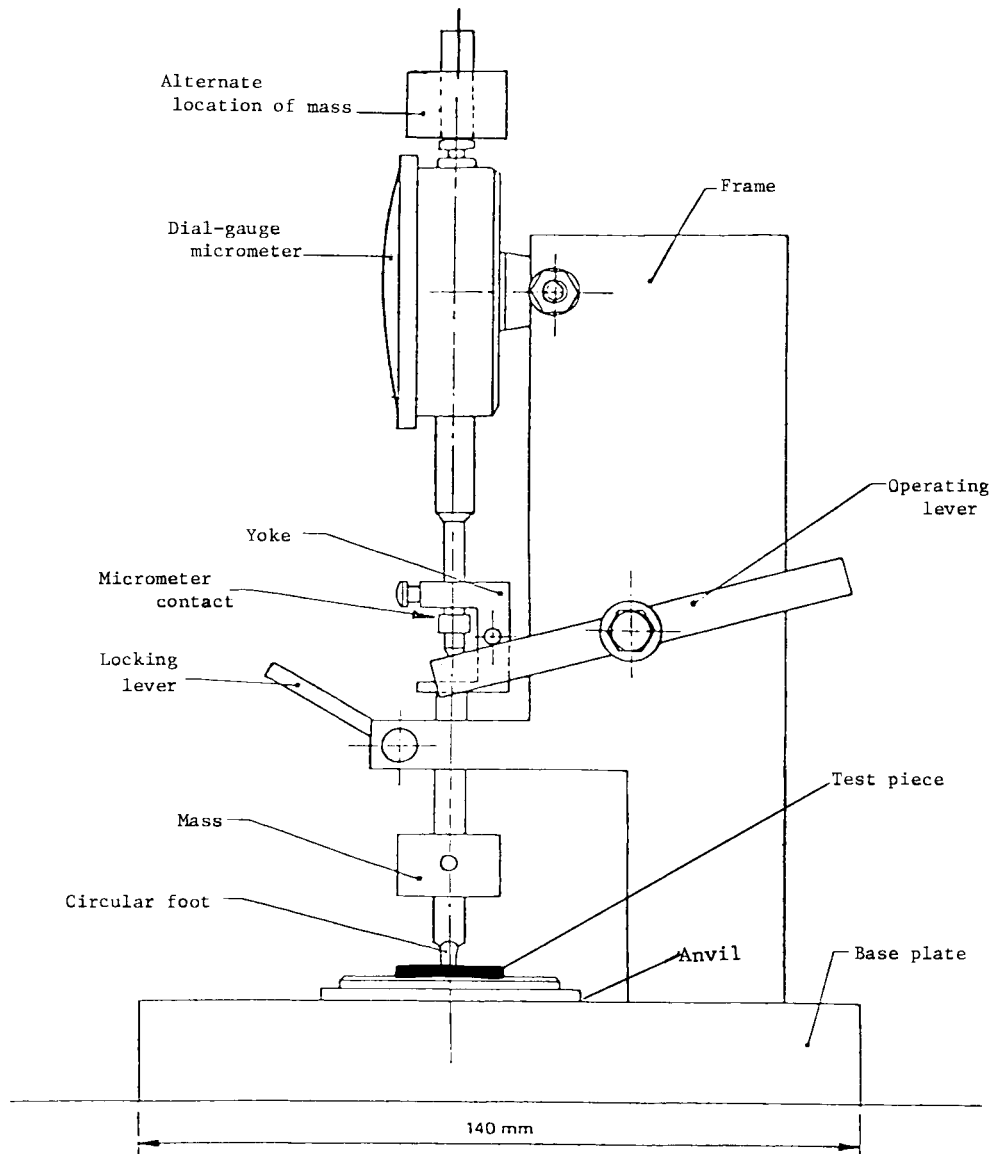

NOTE 1—*Procedure*: Lift the yoke to the raised position and place the specimen between the base plate and circular presser foot. Lower the presser foot and yoke until the rod is resting freely on the test specimen, but with the dial-gage stem still supported. Lock the clamp and then lower the yoke fully. Read the micrometer.

FIG. 1 Example of a Suitable Measuring Apparatus for Procedure A

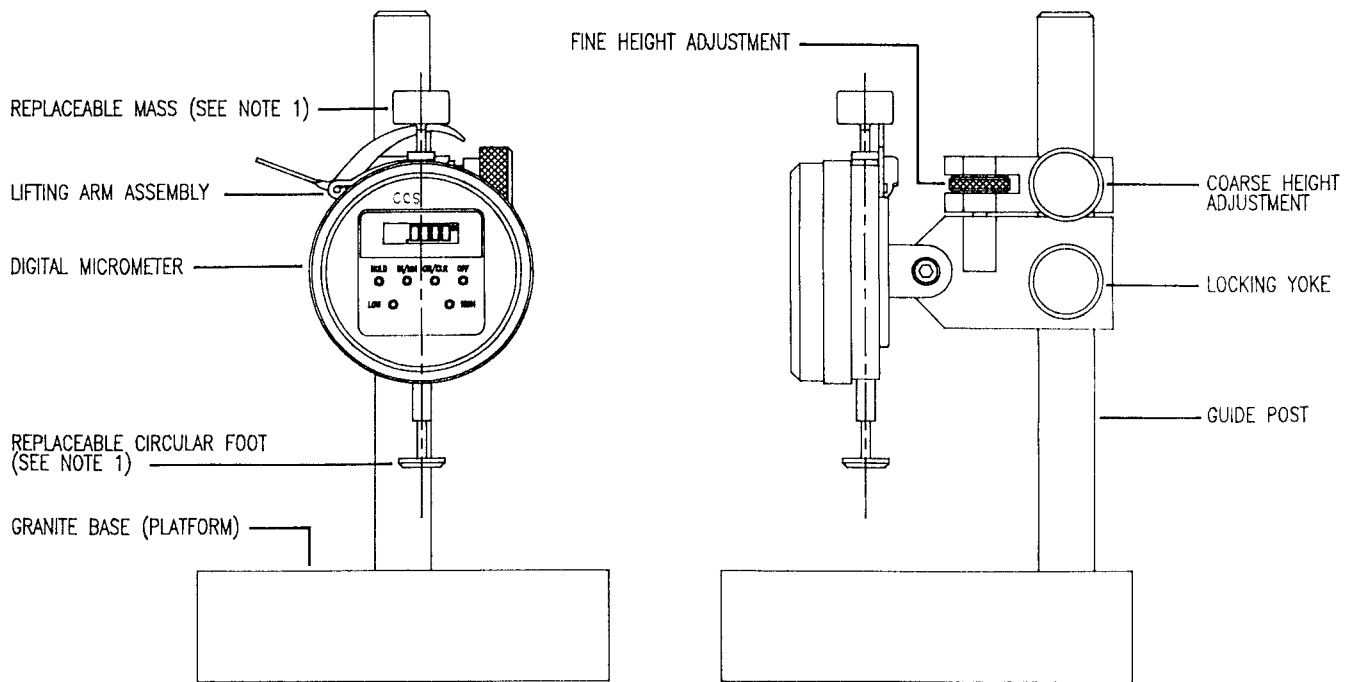

NOTE 1—*Procedure*: Lower the contact foot so it is resting freely on the platform. Reset the micrometer to zero. Return the contact foot to a raised position. Place the test specimen on the platform. Lower the contact foot, gently, until it contacts the test specimen. Read the micrometer.

FIG. 2 Example of a Suitable Apparatus for Procedure A

the dimension being measured or 0.001 mm, whichever is greater.

9.1.2.3 *Rigid Rod*:

(1) terminating in its lower end in a flat circular foot 3 to 10 mm (0.12 to 0.39 in.) in diameter (see Fig. 1). The rod design shall allow various masses to be attached in order to give the operator the capability of varying the pressure exerted on the test specimen, by the presser foot from 10 to 25 kPa (1.55 to 3.6 psi) (see Note 1).

(2) terminating in its upper and lower ends in a threaded orifice. The lower orifice will accommodate the connection of a flat circular foot 3 to 10 mm (0.12 to 0.39 in.) in diameter. The upper orifice will accommodate the attachment of a mass corresponding to the presser foot attached (see Note 1 and Fig. 2) in order to give the operator the capability of varying the pressure exerted on the test specimen by the presser foot from 10 to 25 kPa (1.55 to 3.6 psi).

9.1.3 *Procedure*:

9.1.3.1 When using an instrument equivalent to the one shown in Fig. 1, place the test specimen between the base plate and the circular presser foot. Lower the presser foot until it is resting freely on the test specimen. Read the micrometer to an accuracy within 1 % of the dimension being measured. Repeat the procedure again with the test specimen removed, and the difference between readings is the dimension of the test specimen. The pressure exerted by the presser foot shall be 22 ± 5 kPa (3.2 ± 0.7 psi) (see Note 1) for solid rubber having a hardness equal to or greater than 35 IRHD and 10 ± 2 kPa (1.5 ± 0.3 psi) for solid rubber having a hardness less than 35 IRHD. The presser foot shall not extend over the edge of the area of the test specimen (see Note 2).

9.1.3.2 When using an instrument equivalent to the one

shown in Fig. 2, the micrometer is adjusted so that the presser foot is resting freely on the (polished granite) base. The micrometer is then reset to a “zero” reading. The presser foot is then raised with the lifting lever mechanism. The test specimen is placed beneath the presser foot. The presser foot is lowered gently to the test specimen. Read and record the thickness from the micrometer to an accuracy within 1 % of the dimension being measured immediately after the presser foot contacts the test specimen. The reading displayed digitally is the dimension of the test specimen to within the tolerance (resolution) of the instrument. The pressure exerted by the presser foot shall be 22 ± 5 kPa (3.2 ± 0.7 psi) (see Note 1) for solid rubber having a hardness equal to or greater than 35 IRHD, and 10 ± 2 kPa (1.5 ± 0.3 psi) for solid rubber having a hardness of less than 35 IRHD. The presser foot shall not extend beyond the edge of the test specimen (see Note 2).

NOTE 1—The following lists the masses for various diameters of presser feet which by gravity, produce a pressure of 22 kPa (3.2 psi):

Foot diameter, mm	3.2	4.0	5.0	6.0	6.3	8.0	10.0
Mass required, g	18	28	44	63	70	113	176

NOTE 2—The operator should take care to ensure that the micrometer and guide post assembly is perpendicular to the granite base or other test specimen support surface to within a tolerance of ± 0.002 in. The perpendicularity should be ascertained with the micrometer at the operating height.

9.2 *Procedure A1*:

9.2.1 *Scope*—This procedure is intended for use in determining the thickness of test specimens with irregular, convex, or concave surfaces, using a micrometer with a spherical foot. It is particularly suitable for compression set test specimens.

9.2.2 *Apparatus*—The apparatus shall consist of a micrometer (such as dial or digital-electronic) of one of the following configurations:

9.2.2.1 Two contact members with domed surfaces of spherical radius 12.5 ± 0.1 mm or 0.5 ± 0.005 in. formed on rods 9.5 to 10 mm (0.38 to 0.4 in.) in diameter. The contact members shall exert a force of 0.8 ± 0.1 N (0.18 ± 0.02 lbf) and shall have a scale capable of measuring dimensions to an accuracy within 1 % of the dimension being measured. The reading, if displayed digitally, is the dimension of the test specimen to within the tolerance (resolution) of the instrument.

9.2.2.2 Two contact members with domed surfaces of spherical radius 12.5 ± 0.1 mm or 0.5 ± 0.005 in. in diameter, one as an anvil insert, the other connected to the micrometer. The contact members shall exert a force of 0.8 ± 0.1 N (0.18 ± 0.02 lbf) and shall have a scale capable of measuring dimensions to an accuracy within 1 % of the dimension being measured. The reading displayed digitally is the dimension of the test specimen to within the tolerance (resolution) of the instrument. The anvil is a solid insert with an integral or replaceable contact foot placed in the Bradnick-Warner fixture (see Fig. 3). The contact foot with a domed surface of spherical radius is placed in the micrometer.

NOTE 3—The fixture depicted in Fig. 3 bears the names of its designers and is intended to be reproduced freely.

9.2.2.3 A flat anvil 9.5 ± 0.5 mm (0.38 ± 0.02 in.) in diameter, and a spherical contact foot 6.0 ± 1 mm (0.24 ± 0.04 in.) in diameter. The contact foot shall exert a force of 0.8 ± 0.1 N (0.18 ± 0.02 lbf) and shall have a scale capable of measuring dimensions to an accuracy within 1 % of the dimension being measured. The reading, if displayed digitally, is the dimension of the test specimen to within the tolerance (resolution) of the instrument.

9.2.2.4 A spherical contact foot 6.0 ± 1.0 mm (0.24 ± 0.04 in.) in diameter (see Fig. 4). The contact foot shall exert a force of 0.8 ± 0.1 N (0.18 ± 0.02 lbf) and shall have a scale capable of measuring dimensions to an accuracy within 1 % of the dimension being measured. The reading displayed digitally is the dimension of the test specimen to within the tolerance (resolution) of the instrument. A solid anvil insert 9.5 ± 0.5 mm (0.38 ± 0.02 in.) in diameter extending at least 0.50 in. above the surface of the base plate of the Bradnick-Warner fixture (see Fig. 3).

9.2.3 *Procedure:*

9.2.3.1 When using the instrument described in 9.2.2.1, place the central portion of the test specimen between the two

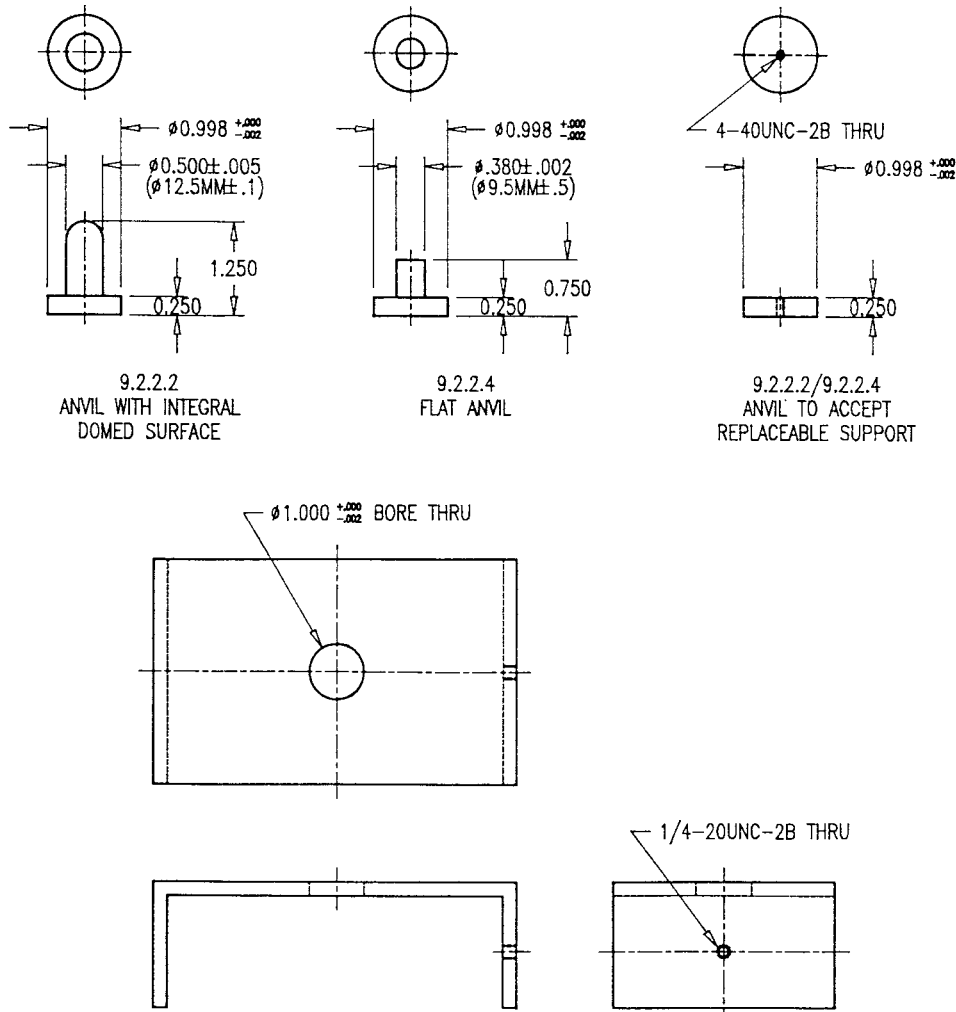
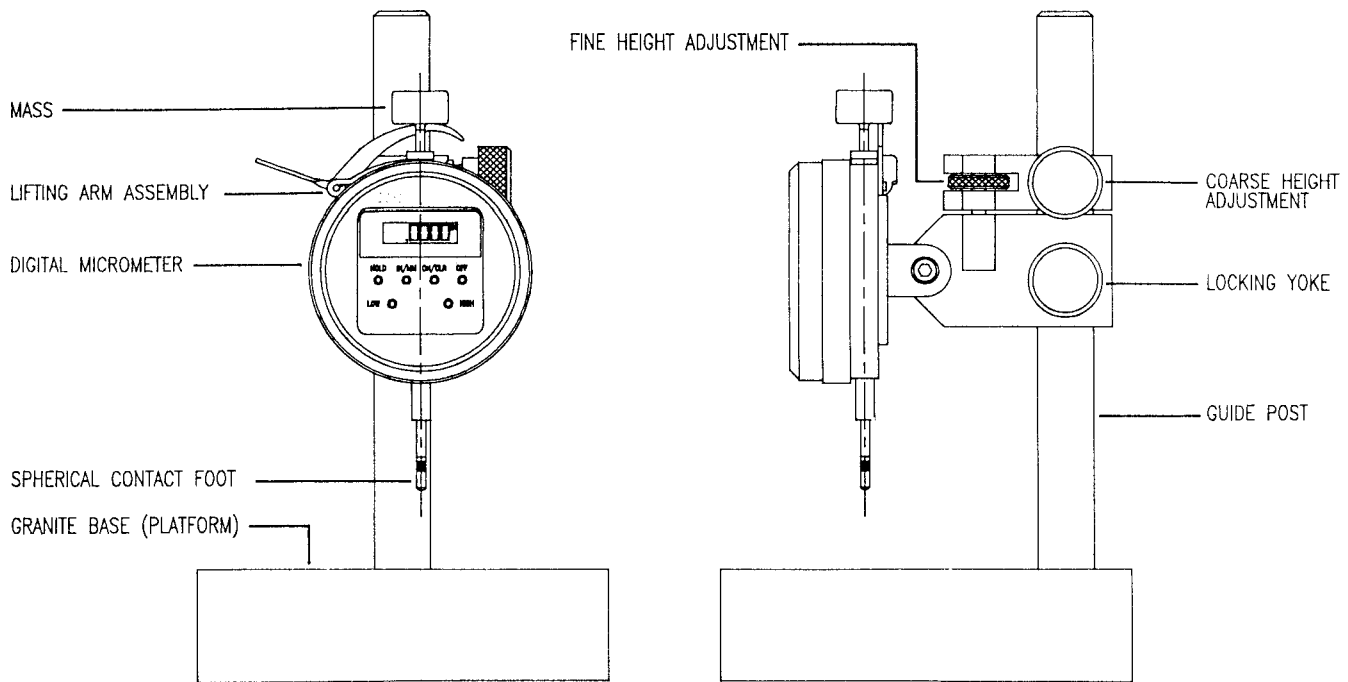

FIG. 3 Bradnick-Warner Support Fixture with Replaceable Anvils



NOTE 1—*Procedure*: Center the anvil to the contact foot (Fig. 2). Lower the contact foot so it is resting freely on the support anvil (Fig. 2). Reset the micrometer to zero. Return the contact foot to a raised position. Place the test specimen on the platform. Lower the contact foot, gently, until it contacts the test specimen. Read the micrometer.

FIG. 4 Example of a Suitable Apparatus for Procedure A1

domed surfaces and lower the presser foot gently until it contacts the surface of the test specimen. Read and record the thickness from the micrometer to an accuracy within 1 % of the dimension being measured immediately after the presser foot contacts the test specimen (see Note 2).

9.2.3.2 When using an instrument described in 9.2.2.2 (see Fig. 4), the micrometer is adjusted so that the presser foot is resting freely on the solid anvil with integral or replaceable spherical foot (see Fig. 3). Care should be taken to align the two domed surfaces (see Note 2). The micrometer is reset to a “zero” reading. The presser foot is raised with the lifting lever mechanism and the test specimen is placed between the domed surfaces. The presser foot is then lowered gently to the test specimen. Read and record the thickness from the micrometer to an accuracy within 1 % of the dimension being measured immediately after the presser foot contacts the test specimen. The reading displayed digitally is the dimension of the test specimen to within the tolerance (resolution) of the instrument.

9.2.3.3 When using an instrument described in 9.2.2.3, the micrometer is adjusted so that the presser foot is resting freely on the anvil. Care should be taken to align the anvil to the presser foot (see Note 2). The micrometer is then reset to a “zero” reading. The presser foot is raised with the lifting lever mechanism and the test specimen is placed on the anvil. The presser foot is then lowered gently to the test specimen. Read and record the thickness from the micrometer to an accuracy within 1 % of the dimension being measured immediately after the presser foot contacts the test specimen. The reading displayed digitally is the dimension of the test specimen to within the tolerance (resolution) of the instrument.

9.2.3.4 When using an instrument described in 9.2.2.4 (see Fig. 4), the micrometer is adjusted so that the presser foot is

resting freely on the anvil (see Fig. 3). Care should be taken to align the anvil contact foot to the presser foot (see Note 2). The micrometer is reset to a “zero” reading. The presser foot is raised with the lifting lever mechanism and the test specimen is placed between the contact surfaces. The presser foot is then lowered gently to the test specimen. Read and record the thickness from the micrometer to an accuracy within 1 % of the dimension being measured immediately after the presser foot contacts the test specimen. The reading displayed digitally is the dimension of the test specimen to within the tolerance (resolution) of the instrument.

9.3 Procedure A2:

9.3.1 *Scope*—This procedure is recommended for determining the thickness of flexible cellular material 30 mm (1.2 in.) or less in thickness when a light contact pressure is required so as not to distort the material. Cellular material over 30 mm in thickness may be measured by Procedure B (see Section 10) or Procedure C (see Section 11).

9.3.2 *Apparatus*—This apparatus shall consist of a suitable micrometer (such as a dial or digital-electronic) with a flat circular presser foot having a contact surface of between 650 mm² (1 in.²) and 1000 mm² (1.5 in.²) and an anvil with a contact area at least equal to the contact area of the flat circular presser foot (see Fig. 4), or an instrument equivalent to the one shown in Fig. 5. The lever arm for raising and lowering the presser foot or the micrometer shaft shall be fitted with a counter mass in order to vary the pressure exerted on the test specimen from 0 to 170 ± 10 Pa (0 to 0.025 ± 0.005 psi). The micrometer shall be capable of measuring dimensions to an accuracy within 1 % of the dimension being measured. Examples of suitable apparatus are shown in Fig. 4 and Fig. 5.

9.3.3 *Procedure*—Place the test specimen, 30 mm (1.2 in.)

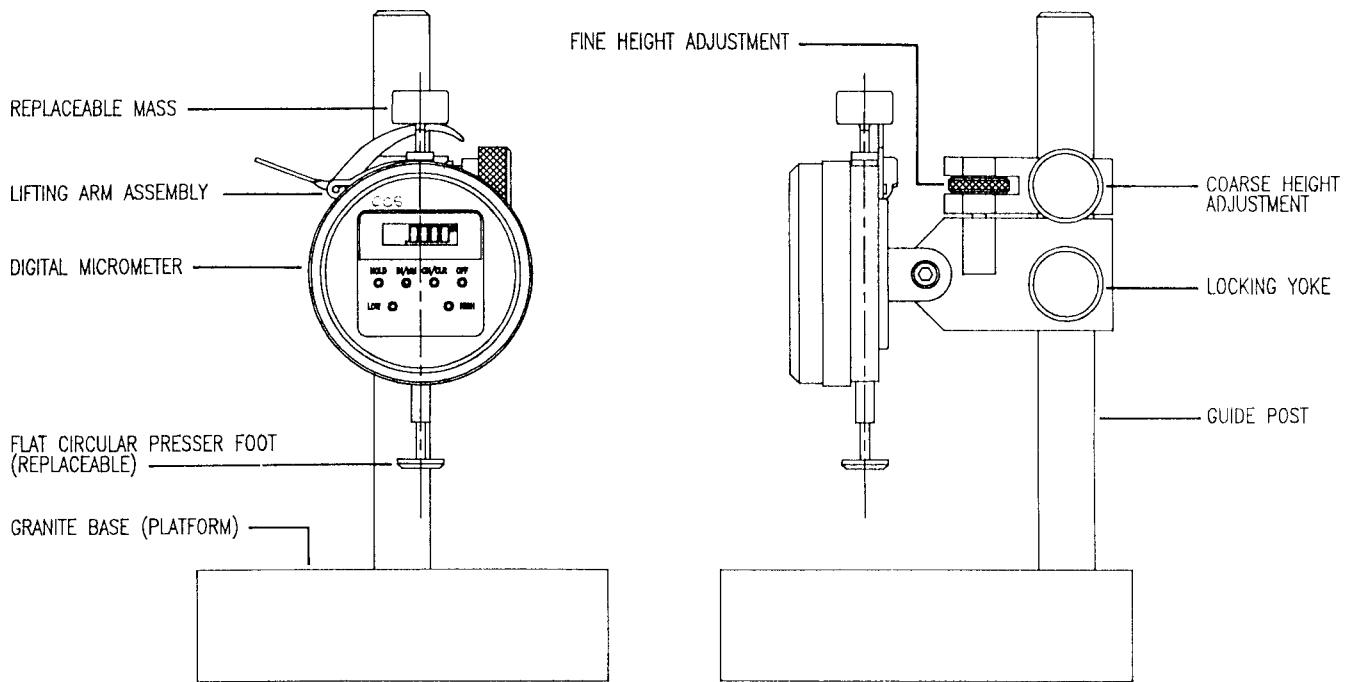

NOTE 1—*Procedure*: Lower the contact foot so it is resting freely on the platform. Reset the micrometer to zero. Return the contact foot to a raised position. Place the test specimen on the platform. Lower the contact foot, gently, until it contacts the test specimen. Read the micrometer at 5 seconds from time of initial contact.

FIG. 5 Example of a Suitable Apparatus for Procedure A2

or less in thickness, on the platform. Adjust the pressure foot force to the desired force specified in the detail specification or test method. Lower the presser foot gently until the foot contacts the surface of the test specimen. Read and record the thickness 5 s after applying the foot, to an accuracy within 1 % of the dimension being measured.

10. Procedure B (Dimensions of 30–100 mm)

10.1 *Scope*—Dimensions of length, width, thickness, diameter, and circumferences from 30 to 100 mm (1.2 to 4 in.) shall be measured by means of a vernier caliper reading to an accuracy within 1 % of the dimension being measured. Each measurement shall be taken along a line perpendicular to the opposing faces of the test specimen or product, which shall be supported so that the dimensions to be measured is not strained. The diameter of the test specimen shall be the distance between the two graduations of the gage that are tangent to the circumference of the specimen. The caliper shall be adjusted so that its measuring surfaces contact the test specimen without compressing it. The circumference, *c*, is calculated by the following equation:

$$c = \pi d \tag{1}$$

where:

π = 3.14, and
d = diameter, mm (or in.).

10.2 *Apparatus*—A steel diameter or Pi tape, which reads directly in outside diameters, may be used to measure the outside diameter.

11. Procedure C (Dimensions Greater than 100 mm)

11.1 *Scope*—Dimensions of length, width, thickness, diam-

eter, and circumferences over 100 mm (4 in.) shall be measured by means of a rule or tape graduated to the nearest 1 mm or 0.03 in. Each measurement shall be taken along a line perpendicular to the opposing surfaces of the test specimen defining the dimension to be measured. When measuring test specimens of flexible foam material care should be taken so as not to distort the test specimen.

11.1.1 Determine the circumference measurement by this procedure in the same manner as described in 10.1 or directly by applying a flexible graduated tape around the test specimen in such a manner that it is in contact with the test specimen at all points. Read the circumference or diameters directly from the tape.

12. Procedure D (Soft Thin Materials)

12.1 *Scope*—This procedure is recommended for determining the thickness of test specimens of soft thin materials or with walls of cylindrical layers (such as hose and tubing) by optical measurement. This procedure is more accurate, but more time consuming than Procedure A.

12.2 *Apparatus*—The apparatus shall consist of a microscope equipped with devices capable of making measurements accurate to approximately 0.005 mm (0.0002 in.). The microscope shall be equipped with a 6 or 8 power eyepiece, an objective of 32-mm focal length, a mechanical stage, and a ruled glass disk or ocular micrometer.

12.3 *Procedure*—If the test specimen is so thin that it will not support itself edgewise, it may be mounted in a slit cut in a cork or other mounting device. Place the ruled glass disk on the cut surface of the cross section with the ruled surface in contact with the test specimen. Read the thickness, if in the

field of view, directly from the rulings on the disk to the nearest 0.005 mm (0.0002 in.). If the thickness is such that it does not all lie within the field of view, move the test specimen by means of the mechanical stage until the complete section thickness passes through the field. Count the rulings on the disk passed over during the movement and record the distance to the nearest 0.005 mm. When the scale is used in the eyepiece, place the ruled glass disk or ocular micrometer in the ocular and calibrate by placing a graduated scale on the stage. Place the test specimen on the stage with the surface to be measured perpendicular to the optical axis of the microscope so as to expose the full thickness. Focus the microscope on the test specimen and determine the thickness by counting the divisions of the ruled disk in the eyepiece that cover the distance from one edge of the test specimen to the other. Record the distance to the nearest 0.005 mm. Equally space four measurements over the test specimen.

12.4 *Circumference and Diameter*—The optical procedure described in 12.3 is particularly suited for determining the diameters of test specimens having circular cross sections less than 38 mm (1.5 in.). The circumference, c , is calculated by the following equation:

$$c = \pi d \quad (2)$$

where:

$$\pi = 3.14, \text{ and}$$

$$d = \text{diameter, mm (or in.).}$$

The results shall be reported to the nearest 0.005 mm (0.0002 in.).

13. Procedure E (Circumference Graduated Cone)

13.1 *Scope*—This procedure is intended for use in directly determining the inner diameter and circumference of test specimens for physical tests by use of a graduated cone or tapered plug gage.

13.2 *Apparatus*—*Tapered Plug Gage*, graduated to indicate variations of 1 mm (0.04 in.) in diameter.

13.3 *Procedure*—Fit the test specimen over the tapered plug gage in such a manner that it is not distorted. Read the graduation on the gage that just comes in contact with the inner circumference of the test specimen directly from the gage, and record the value of the circumference or diameter, as applicable, to the nearest 1 mm (0.04 in.).

14. Keywords

14.1 dimensions; measurement

The American Society for Testing and Materials takes no position respecting the validity of any patent rights asserted in connection with any item mentioned in this standard. Users of this standard are expressly advised that determination of the validity of any such patent rights, and the risk of infringement of such rights, are entirely their own responsibility.

This standard is subject to revision at any time by the responsible technical committee and must be reviewed every five years and if not revised, either reapproved or withdrawn. Your comments are invited either for revision of this standard or for additional standards and should be addressed to ASTM Headquarters. Your comments will receive careful consideration at a meeting of the responsible technical committee, which you may attend. If you feel that your comments have not received a fair hearing you should make your views known to the ASTM Committee on Standards, at the address shown below.

This standard is copyrighted by ASTM, 100 Barr Harbor Drive, PO Box C700, West Conshohocken, PA 19428-2959, United States. Individual reprints (single or multiple copies) of this standard may be obtained by contacting ASTM at the above address or at 610-832-9585 (phone), 610-832-9555 (fax), or service@astm.org (e-mail); or through the ASTM website (www.astm.org).